

Calculus For the Life Sciences: A Modeling Approach

Volume I. Difference Equations, Calculus, and Differential Equations

James L. Cornette and Ralph A. Ackerman

Iowa State University, Ames, Iowa 50011

This material is the property of Professors Cornette and Ackerman and is covered by a license for **Non-Commercial Use** written by Creative Designs that may be found at <http://creativecommons.org/licenses/by-nc-nd/3.0/> and <http://creativecommons.org/licenses/by-nc-nd/3.0/legalcode>

Briefly, you may use this work and distribute it to others on a **non-commercial basis** if you give us proper **attribution**, but **you may not alter, transform, or build upon this work.**

We have obtained copyright permission to use some figures. Permissions will have to be renewed for any of these figures used in a derivative work.

Duane Nykamp of the University of Minnesota is writing **Math Insight**, <http://mathinsight.org>, a collection of web pages and applets designed to shed light on concepts underlying a few topics in mathematics. Some of his pages are based on our material and we point to those pages at critical points in our text.

A review of this text by Steven Deckelman and George Jennings appears in the Mathematical Association of America Digital Library at <http://mathdl.maa.org/mathDL/19/?pa=reviews&sa=viewBook&bookId=73094>

Copyright ©2011 - 2013 James L. Cornette and Ralph A. Ackerman.

We thank some journal publishers who allow limited use of figures from papers in their journals either without charge (Nature, Entomological Society of America, Behaviour, Journal of Animal Ecology, Antibiotics and Chemotherapy) or with a small charge (Science). We also thank several individuals who have given permission to use their material.

Wikipedia and government web sites and a few other sites have been very useful in providing some text images.

This text is a product of a two-semester calculus course for life sciences students in which students gathered biological data in a laboratory setting that was used to motivate the concepts of calculus. The book contains data from experiments, but does not require that students do laboratory experiments.

Several MATLAB programs are provided for exercises and for explicit statement of a method. All but two or three are short, almost in the form of pseudocode, and can be readily translated to other technology, including that of programmable hand calculators.

All of the graphs in the text were created using MATLAB licensed to the Department of Mathematics at Iowa State University, Ames, Iowa. The text was written in LaTeX using the WinEdt software, also licensed to the Department of Mathematics at Iowa State University, Ames, Iowa. More than 50 color figures were converted from .jpg to .eps using <http://image.online-convert.com/convert-to-eps>.

About Calculus for the Life Sciences: A Modeling Approach

Our writing is based on three premises. First, life sciences students are motivated by and respond well to actual data related to real life sciences problems. Second, the ultimate goal of calculus in the life sciences primarily involves modeling living systems with difference and differential equations. Understanding the concepts of derivative and integral are crucial, but the ability to compute a large array of derivatives and integrals is of secondary importance. Third, the depth of calculus for life sciences students should be comparable to that of the traditional physics and engineering calculus course; else life sciences students will be short changed and their faculty will advise them to take the 'best' (engineering) course.

The common pedagogical goal of converting students from passive listeners or readers to active problem solvers is fundamental to this text. Distributed throughout are 'Explore' problems that expand the text and in some cases are crucial to the development of the material.

In our text, mathematical modeling and difference and differential equations lead, closely follow, and extend the elements of calculus. Chapter one introduces mathematical modeling in which students write descriptions of some observed processes and from these descriptions derive first order linear difference equations whose solutions can be compared with the observed data. In chapters in which the derivatives of algebraic, exponential, or trigonometric functions are defined, biologically motivated differential equations and their solutions are included. The chapter on partial derivatives includes a section on the diffusion partial differential equation. There is a chapter on systems of two difference equations.

The derivative and integral are carefully defined and distinguished from the discrete data of the laboratories. The analysis of calculus thus extends the discrete laboratory observations. The Fundamental Theorem of Calculus is clearly explained on a purely analytical basis; it seems to not lend itself to laboratory exercise. An 'Explore' problem asks students to give reasons for the steps in the analysis.

We have also included some traditional and not necessarily biological applications of the derivative and integral (max-min, related rates, area, volume, surface area problems) because they have proved over many years to be useful to students in gaining an understanding of calculus.

The authors are grateful to the Division of Undergraduate Education of the National Science Foundation for support in 1994-1996 to develop the course on which this text is based. We are also grateful to numerous students who learned from the early versions of the text and to faculty colleagues, Warren Dolphin, Brin Keller, and Gail Johnston, who collaborated in the development and teaching of the course.

All of the graphs in the text were created using MATLAB licensed to the Department of Mathematics at Iowa State University, Ames, Iowa. The text was

written in LaTeX using the WinEdt software, also licensed to the Department of Mathematics at Iowa State University, Ames, Iowa. More than 50 color figures were converted from .jpg to .eps using Online-Convert.com.

We thank some journal publishers who allow limited use of figures from papers in their journals either without charge (Nature, Entomological Society of America, Behaviour, Journal of Animal Ecology, Antibiotics and Chemotherapy) or with a small charge (Science). A number of our figures were downloaded from Wikipedia and government web sites

With amazing insight and energy, Louis Gross and John Jungck have led and supported the mathematics in biology education community for almost a quarter of a century, and they have supported our program in several ways. Lou Gross maintains several web resources, links to which may be found on his personal web page. John Jungck's work is well represented on the Bioquest web page.

JLC is particularly grateful to Carolyn, his wife, who has strongly supported the writing of this work and to Charles DeLisi, Jay Berzofsky, and Hanah Margalit who introduced him to real and incredibly interesting biology problems. He was extraordinarily fortunate to study under Professor R. L. Moore at the University of Texas who greatly enhanced his thinking in mathematics and in other areas of interest.

About the Authors

James L. Cornette taught university level mathematics for 45 years as a graduate student at the University of Texas and a faculty member at Iowa State University. His research includes point set topology, genetics, biomolecular structure, viral dynamics, and paleontology and has been published in *Fundamenta Mathematica*, *Transactions of the American Mathematical Society*, *Proceedings of the American Mathematical Society*, *Heredity*, *Journal of Mathematical Biology*, *Journal of Molecular Biology*, and the biochemistry, the geology, and the paleontology sections of the *Proceedings of the National Academy of Sciences, USA*. Dr. Cornette received an Iowa State University Outstanding Teacher Award in 1973, was a Fulbright lecturer at the Universiti Kebangsaan Malaysia in 1973-74, worked in the Laboratory of Mathematical Biology in the National Cancer Institute, NIH in 1985-1987, and was named University Professor at Iowa State University in 1998. He retired in 2000 and began graduate study at the University of Kansas where he earned a master's degree in Geology (Paleontology) in 2002. Presently he is a volunteer in the Earth Sciences Division of the Denver Museum of Nature and Science.

Ralph A. Ackerman is a professor in the Department of Ecology, Evolution and Organismal Biology at Iowa State University. He has been a faculty member since 1981 where his research focuses on describing and understanding the environmental physiology of vertebrate embryos, especially reptile and bird embryos. His approach is typically interdisciplinary and employs both theoretical and experimental techniques to generate and test hypotheses. He currently examines water exchange by reptile eggs during incubation and temperature dependent sex determination in reptiles.

**Answers to select exercises are available at the web site,
<http://cornette.public.iastate.edu/CLS.html>**

Basic formulas appear on the next two pages.

$$F'(a) = \lim_{b \rightarrow a} \frac{F(b) - F(a)}{b - a} = \lim_{h \rightarrow 0} \frac{F(a + h) - F(a)}{h}$$

Primary Formulas

$$\begin{aligned} [C]' &= 0 & [e^t]' &= e^t & [\sin t]' &= \cos t \\ [t^c]' &= c t^{c-1} & [\ln t]' &= \frac{1}{t} & [\cos t]' &= -\sin t \end{aligned}$$

Combination Rules

$$\begin{aligned} [u(t) \times v(t)]' &= u'(t) \times v(t) + u(t) \times v'(t) \\ [C \times u(t)]' &= C \times u'(t) \\ [u(t) + v(t)]' &= u'(t) + v'(t) \\ \left[\frac{u(t)}{v(t)} \right]' &= \frac{v(t) \times u'(t) - u(t) \times v'(t)}{(v(t))^2} \\ [G(u(t))]' &= G'(u(t)) \times u'(t) \end{aligned}$$

Chain Rule Special Cases

$$\begin{aligned} [(u(t))^n]' &= n (u(t))^{n-1} \times u'(t) \\ [e^{u(t)}]' &= e^{u(t)} \times u'(t) & [\sin(u(t))]' &= \cos(u(t)) \times u'(t) \\ [\ln(u(t))]' &= \frac{1}{u(t)} \times u'(t) & [\cos(u(t))]' &= -\sin(u(t)) \times u'(t) \end{aligned}$$

One special case of the chain rule is very important to the biological sciences.

$$[e^{kt}]' = e^{kt} \times k$$

Solutions to Difference Equations

$$x_{t+1} = K x_t \implies x_t = x_0 K^t$$

$$x_{t+2} + p x_{t+1} + q x_t = 0 \implies x_t = \begin{cases} A r_1^t + B r_2^t & \text{where } r_1 \text{ and } r_2 \\ \text{or} & \text{are the roots to} \\ A r_1^t + B t r_1^t & r^2 + p r + q = 0 \end{cases}$$

Solutions to Differential (or Derivative) Equations

$$x'(t) = k x(t) \implies x(t) = x(0) e^{kt}$$

$$x''(t) + p x'(t) + q x(t) = 0 \implies x(t) = \begin{cases} A e^{r_1 t} + B e^{r_2 t} & \text{where } r_1 \text{ and } r_2 \\ \text{or} & \text{are the roots to} \\ A e^{r_1 t} + B t e^{r_1 t} & r^2 + p r + q = 0 \end{cases}$$

$$\int_a^b f(t) dt = \lim_{\|\Delta\| \rightarrow 0} \sum_{k=1}^n f(\tau_k) \times (t_k - t_{k-1}), \quad \int_b^a f(t) dt = - \int_a^b f(t) dt, \quad \int_a^a f(t) dt = 0$$

$$\int_a^b (f(t) + g(t)) dt = \int_a^b f(t) dt + \int_a^b g(t) dt, \quad \int_a^b cf(t) dt = c \int_a^b f(t) dt$$

$$\int_a^c f(t) dt + \int_c^b f(t) dt = \int_a^b f(t) dt \quad \int_{a+c}^{b+c} f(t-c) dt = \int_a^b f(t) dt$$

$$f(t) \leq g(t) \text{ for all } t \text{ in } [a, b] \implies \int_a^b f(t) dt \leq \int_a^b g(t) dt$$

$$G(x) = \int_a^x f(t) dt \implies G'(x) = f(x), \quad \int_a^b F'(t) dt = F(b) - F(a) = F(t) \Big|_a^b,$$

$$\int 0 du = C \quad \int e^u du = e^u + C \quad \int \sin u du = -\cos u + C$$

$$\int u^n du = \frac{u^{n+1}}{n+1} + C \quad n \neq -1 \quad \int \frac{1}{u} du = \ln u + C \quad \int \cos u du = \sin u + C$$

$$\int f(t) \times g'(t) dt = f(t) \times g(t) - \int f'(t) \times g(t) dt$$

$$\text{If } u = g(z) \quad \text{and} \quad \begin{matrix} a = g(c) \\ b = g(d), \end{matrix} \quad \int_a^b f(u) du = \int_c^d f(g(z)) g'(z) dz$$

$$\text{Moment of mass} = \int_a^b (x-c)\delta(x)A(x) dx. \quad \text{Center of mass} = c = \frac{\int_a^b x\delta(x)A(x) dx}{\int_a^b \delta(x)A(x) dx}.$$

$$\text{Length of the graph of } f \text{ is } \int_a^b \sqrt{1 + (f'(x))^2} dx$$

$$\text{Solids of Revolution: Volume} = \int_a^b \pi (f(x))^2 dx \quad \text{Surface} = \int_a^b 2\pi f(x) \sqrt{1 + (f'(x))^2} dx$$

$$\int_a^\infty f(t) dt = \lim_{R \rightarrow \infty} \int_a^R f(t) dt \quad \int_R \int F(P) dA = \int_a^b \int_{f(x)}^{g(x)} F(x, y) dy dx$$

Contents

1 Mathematical Models of Biological Processes	1
1.1 Experimental data, bacterial growth.....	3
1.1.1 Steps towards building a mathematical model.....	5
1.1.2 Concerning the validity of a model.....	9
1.2 Solution to $P_{t+1} - P_t = r P_t$	11
1.3 Sunlight depletion in a lake or ocean.....	14
1.4 Doubling Time and Half-Life.....	22
1.5 Quadratic Solution Equations: Mold growth.....	25
1.6 Constructing a Mathematical Model of Penicillin Clearance.....	32
1.7 Movement toward equilibrium.....	35
1.8 Solution to the dynamic equation $P_{t+1} - P_t = r P_t + b$	41
1.9 Light Decay with Distance.....	42
1.10 Data modeling vs mathematical models.....	46
1.11 Summary.....	49
2 Descriptions of Biological Patterns	53
2.1 Environmental Sex Determination in Turtles.....	53
2.2 Functions and Simple Graphs.....	55
2.2.1 Three definitions of “Function”.....	55
2.2.2 Simple graphs.....	58
2.2.3 Functions in other settings.....	62
2.3 Function notation.....	64
2.4 Polynomial functions.....	67
2.5 Least squares fit of polynomials to data.....	70
2.6 New functions from old.....	74
2.6.1 Arithmetic combinations of functions.....	74
2.6.2 The inverse of a function.....	76
2.6.3 Finding the equation of the inverse of a function.....	79
2.7 Composition of functions.....	85
Formulas for function composition.....	86
2.8 Periodic functions and oscillations.....	91
2.8.1 Trigonometric Functions.....	98
3 The Derivative	103
3.1 Tangent to the graph of a function.....	104
3.2 Limit and rate of change as a limit.....	123
3.3 The derivative function, F^0	134
3.4 Mathematical models using the derivative.....	143

3.4.1	Mold growth.	143
3.4.2	Difference Equations and Differential Equations.	144
3.4.3	Chemical kinetics.	145
	Butyl chloride.	146
3.5	Derivatives of Polynomials, Sum and Constant Factor Rules	149
3.5.1	Velocity as a derivative.	154
3.5.2	Local Maxima and Local Minima.	155
3.6	The second derivative and higher order derivatives.	162
3.6.1	Falling objects.	165
3.7	Left and right limits and derivatives; limits involving infinity.	170
3.8	Summary of Chapter 3, The Derivative.	173
4	Continuity and the Power Chain Rule	176
4.1	Continuity.	176
4.2	The Derivative Requires Continuity.	184
4.3	The generalized power rule.	187
4.3.1	The Power Chain Rule.	191
4.4	Applications of the Power Chain Rule.	194
4.5	Some optimization problems.	198
4.6	Implicit differentiation.	204
4.7	Summary of Chapter 4	210
5	Exponential and Logarithmic Functions	212
5.1	Derivatives of Exponential Functions.	212
5.2	The number e .	217
5.2.1	Proof that $\lim_{h \rightarrow 0} (1 + h)^{1/h}$ exists.	221
5.3	The natural logarithm \ln .	228
5.4	The derivative of e^{kt} .	230
5.5	The derivative equation $P'(t) = k P(t)$.	235
5.5.1	Two primitive modeling concepts.	240
5.5.2	Continuous-space analysis of light depletion.	244
5.5.3	Doubling time and half-life.	246
5.5.4	Semilogarithm and LogLog graphs.	247
5.5.5	Relative Growth Rates and Allometry.	249
5.6	Exponential and logarithm chain rules.	262
5.7	Summary.	269
6	Derivatives of Products, Quotients, Compositions	271
6.1	Derivatives of Products and Quotients.	271
6.2	The chain rule.	283
6.3	Derivatives of inverse functions.	291
6.4	Summary of Chapter 6.	294
7	Derivatives of the Trigonometric Functions	297
7.1	Radian Measure.	297
7.2	Derivatives of trigonometric functions	302
7.3	The Chain Rule with trigonometric functions.	310
7.4	The Equation $y'' + \omega^2 y = 0$.	315

7.4.1	Resistance.....	319
7.5	Elementary predator-prey oscillation.....	323
7.6	Periodic systems.....	332
7.6.1	Control switches.....	333
7.6.2	Earthquakes.....	336
7.6.3	The circadian clock.....	339
8	Applications of Derivatives	341
8.1	Some geometry of the derivative.....	341
8.1.1	Convex up, concave down, and inflection points.....	346
8.1.2	The arithmetic mean is greater than or equal to the geometric mean.....	347
8.2	Some Traditional Max-Min Problems.....	350
8.2.1	The Second Derivative Test.....	355
8.2.2	How to solve these problems.....	357
8.3	Life Sciences Optima.....	365
8.4	Related Rates.....	375
8.5	Finding roots to $f(x) = 0$	380
8.6	Harvesting of whales.....	385
8.7	Summary and review of Chapters 3 to 8.....	388
8.7.1	Derivative Formulas.....	390
8.7.2	Applications of the derivative.....	393
8.7.3	Differential Equations.....	394
9	The Integral	397
9.1	Areas of Irregular Regions.....	397
9.2	Areas Under Some Algebraic Curves.....	409
9.3	A general procedure for computing areas.....	417
9.3.1	Trapezoidal approximation.....	420
9.4	The Integral.....	430
9.4.1	A more flexible definition of integral.....	436
9.5	Properties of the integral.....	441
9.5.1	Negatives.....	444
9.6	Cardiac Output.....	446
9.7	Chlorophyll energy absorption.....	450
10	The Fundamental Theorem of Calculus	455
10.1	An Example.....	455
10.2	The Fundamental Theorem of Calculus.....	458
10.3	The parallel graph theorem.....	464
10.4	Fundamental Theorem of Calculus II.....	468
10.5	Integral Formulas.....	471
10.5.1	Using the chain rules.....	473
10.5.2	Integration by parts.....	475
11	Applications of the Fundamental Theorem	480
11.1	Volume.....	480
11.2	Change the variable of integration.....	488
11.3	Center of mass.....	491

11.4 Arc length and Surface Area.	496
11.5 The improper integral, $\int_a^{\infty} f(t) dt$	500
12 The Mean Value Theorem; Taylor Polynomials	507
12.1 The Mean Value Theorem.	507
12.2 Monotone functions; high point second derivative test	515
12.3 Approximating functions with quadratic polynomials.	520
12.4 Polynomial approximation anchored at 0.	523
12.5 Polynomial Approximations to Solutions of ODE's	527
12.6 Polynomial approximation at anchor $a = 0$	531
12.7 The Accuracy of the Taylor Polynomial Approximations.....	537
13 Two Variable Calculus and Diffusion	544
13.1 Partial derivatives of functions of two variables.	544
13.2 Maxima and minima of functions of two variables.	554
13.3 Integrals of functions of two variables.....	565
13.4 The diffusion equation $u_t(x, t) = c^2 u_{xx}(x, t)$	573
13.4.1 Numerical solutions to the diffusion equation.	579
A Summation Notation and Mathematical Induction	587
A.1 Summation Notation.....	587
A.2 Mathematical Induction.	589

Chapter 1

Mathematical Models of Biological Processes

Where are we going?

Science involves observations, formulation of hypotheses, and testing of hypotheses. This book is directed to quantifiable observations about living systems and hypotheses about the processes of life that are formulated as mathematical models. Using three biologically important examples, growth of the bacterium *Vibrio natriegens*, depletion of light below the surface of a lake or ocean, and growth of a mold colony, we demonstrate how to formulate *mathematical models* that lead to *dynamic equations* descriptive of natural processes. You will see how to compute *solution equations* to the dynamic equations and to test them against experimental data.

Examine the picture of the mold colony (Day 6 of Figure 1.14) and answer the question, “Where is the growth?” You will find the answer to be a fundamental component of the process.

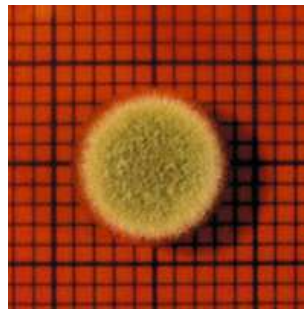

In our language, a **mathematical model** is a concise verbal description of the interactions and forces that cause change with time or position of a biological system (or physical or economic or other system). The modeling process begins with a clear verbal statement based on the scientist’s understanding of the interactions and forces that govern change in the system. In order for mathematical techniques to assist in understanding the system, the verbal statement must be translated into an equation, called the **dynamic equation** of the model. Knowledge of the initial state of a system and the dynamic equation that describes the forces of change in the system is often sufficient to forecast an observed pattern of the system. A **solution equation** may be derived from the dynamic equation and an initial state of the system and a graph or table of values of the solution equation may then be compared with the observed pattern of nature. The extent to which solution equation matches the pattern is a measure of the validity of the mathematical model.

Mathematical modeling is used to describe the underlying mechanisms of a large number of processes in the natural or physical or social sciences. The chart in Figure 1.1 outlines the steps

followed in finding a mathematical model.

Initially a scientist examines the biology of a problem, formulates a concise description, writes equations capturing the essence of the description, solves the equations, and makes predictions about the biological process. This path is marked by the bold arrows in Figure 1.1. It is seldom so simple! Almost always experimental data stimulates exchanges back and forth between a biologist and a computational scientist (mathematician, statistician, computer scientist) before a model is obtained that explains some of the biology. This additional exchange is represented by lightly marked arrows in Figure 1.1.

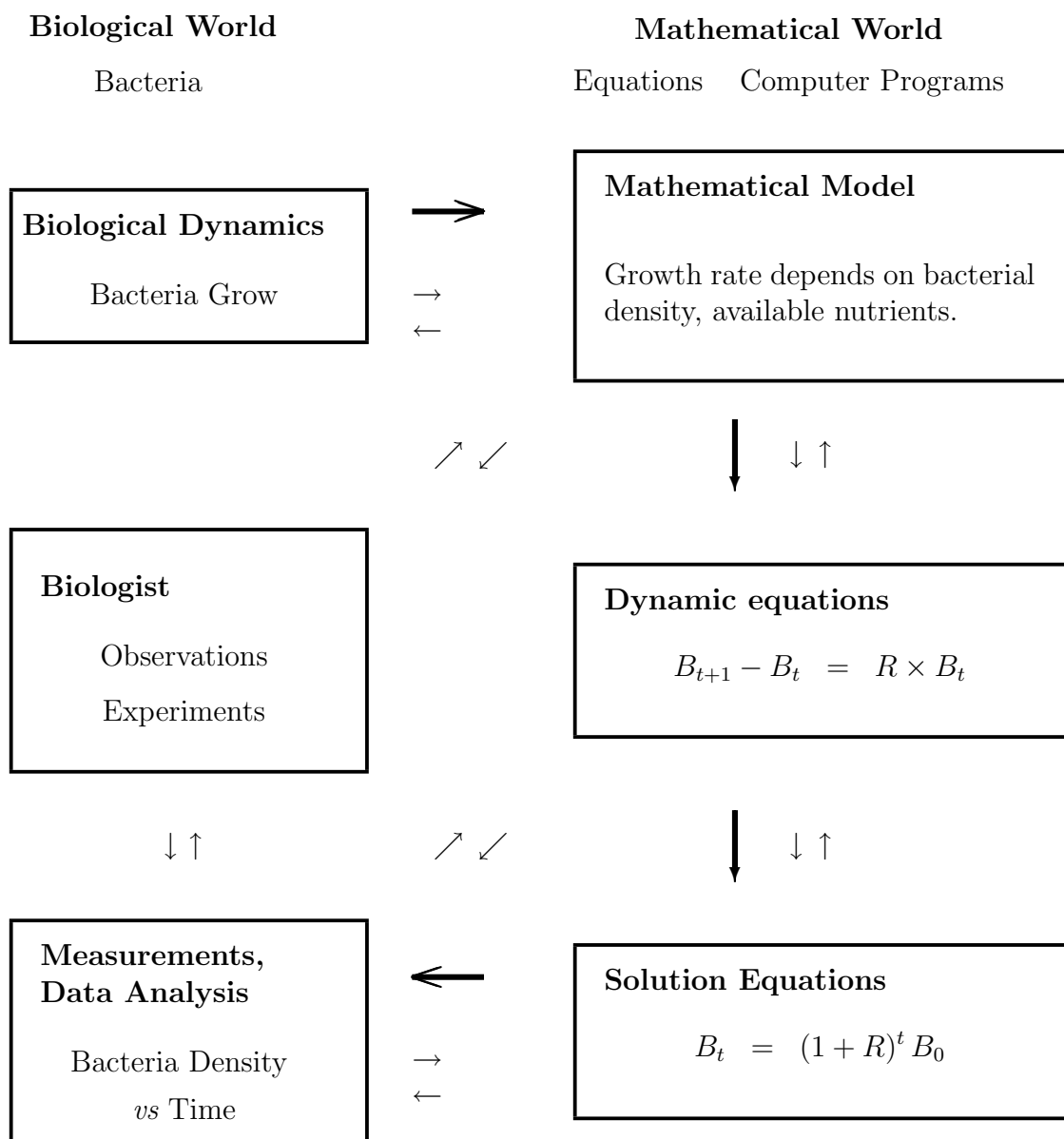

Figure 1.1: Biology - Mathematics: Information flow chart for bacteria growth.

An initial approach to modeling may follow the bold arrows in Figure 1.1. For *V. natriegens* growth the steps might be:

- The scientist ‘knows’ that 25% of the bacteria divide every 20 minutes.

- If so, then bacteria increase, $B_{t+1} - B_t$, should be $0.25 B_t$ where t marks time in 20-minute intervals and B_t is the amount of bacteria at the end of the t th 20-minute interval.
- From $B_{t+1} - B_t = 0.25 B_t$, the scientist may conclude that

$$B_t = 1.25^t B_0$$

(More about this conclusion later).

- The scientist uses this last equation to predict what bacteria density will be during an experiment in which *V. natriegens*, initially at 10^6 cells per milliliter, are grown in a flask for two hours.
- In the final stage, an experiment is carried out to grow the bacteria, their density is measured at selected times, and a comparison is made between observed densities and those predicted by equations.

Reality usually strikes at this stage, for the observed densities may not match the predicted densities. If so, the additional network of lightly marked arrows of the chart is implemented.

- Adjustments to a model of *V. natriegen* growth that may be needed include:
 1. *Different growth rate*: A simple adjustment may be that only, say 20%, of the bacteria are dividing every 20 minutes and $B_t = 1.2^t B_0$ matches experimental observations.
 2. *Variable growth rate*: A more complex adjustment may be that initially 25% of the bacteria were dividing every 20 minutes but as the bacteria became more dense the growth rate fell to, say only 10% dividing during the last 20 minutes of the experiment.
 3. *Age dependent growth rate*: A different adjustment may be required if initially all of the bacteria were from newly divided cells so that, for example, most of them grow without division during the first two 20-minute periods, and then divide during the third 20-minute interval.
 4. *Synchronous growth*: A relatively easy adjustment may account for the fact that bacterial cell division is sometimes regulated by the photo period, causing all the bacteria to divide at a certain time of day. The green alga *Chlamydomonas moewussi*, for example, when grown in a laboratory with alternate 12 hour intervals of light and dark, accumulate nuclear subdivisions and each cell divides into eight cells at dawn of each day¹.

1.1 Experimental data, bacterial growth.

Population growth was historically one of the first concepts to be explored in mathematical biology and it continues to be of central importance. Thomas Malthus in 1821 asserted a theory

“that human population tends to increase at a faster rate than its means of subsistence and that unless it is checked by moral restraint or disaster (as disease, famine, or war) widespread poverty and degradation inevitably result.”²

¹Emil Bernstein, *Science* **131** (1960), 1528.

²Merriam Webster’s Collegiate Dictionary, Tenth Edition.

In doing so he was following the bold arrows in Figure 1.1. World population has increased approximately six fold since Malthus' dire warning, and adjustments using the additional network of the chart are still being argued.

Duane Nykamp of the University of Minnesota is writing **Math Insight**, <http://mathinsight.org>, a collection of web pages and applets designed to shed light on concepts underlying a few topics in mathematics. One of the pages, http://mathinsight.org/bacterial_growth_initial_model, is an excellent display of the material of this section.

Bacterial growth data from a *V. natriegens* experiment are shown in Table 1.1. The population was grown in a commonly used nutrient growth medium, but the pH of the medium was adjusted to be pH 6.25³.

Table 1.1: Measurements of bacterial density.
The units of "Population Density" are those of absorbance as measured by the spectrophotometer.

pH 6.25			
Time (min)	Time Index t	Population Density B_t	Pop Change/ Unit Time $(B_{t+1} - B_t)/1$
0	0	0.022	0.014
16	1	0.036	0.024
32	2	0.060	0.041
48	3	0.101	0.068
64	4	0.169	0.097
80	5	0.266	

How do you measure bacteria density? Ideally you would place, say 1 microliter, of growth medium under a microscope slide and count the bacteria in it. This is difficult, so the procedure commonly used is to pass a beam of light through a sample of growth medium and measure the amount of light absorbed. The greater the bacterial density the more light that is absorbed and thus bacterial density is measured in terms of *absorbance* units. The instrument used to do this is called a *spectrophotometer*.

The spectrophotometer gives you a measure of light absorbance which is directly proportional to the bacterial density (that is, light absorbance is a constant times bacterial density). Absorbance is actually defined by

$$\text{Absorbance} = -\log_{10} \frac{I_t}{I_0}$$

³The experiment was a semester project of Deb Christensen in which several *V. natriegens* populations were grown in a range of pH values.

where I_0 is the light intensity passing through the medium with no bacteria present and I_t is the light intensity passing through the medium with bacteria at time t .

It may seem more natural to use

$$\frac{I_0 - I_t}{I_0}$$

as a measure of absorbance. The reason for using $\log_{10} \frac{I_t}{I_0}$ is related to our next example for light absorbance below the surface of a lake, but is only easy to explain after continuous models are studied. See Chapter ?? (Exercise ??).

1.1.1 Steps towards building a mathematical model.

This section illustrates one possible sequence of steps leading to a mathematical model of bacterial growth.

Step 1. Preliminary Mathematical Model: Description of bacterial growth.

Bacterial populations increase rapidly when grown at low bacterial densities in abundant nutrient. The population increase is due to binary fission – single cells divide asexually into two cells, subsequently the two cells divide to form four cells, and so on. The time required for a cell to mature and divide is approximately the same for any two cells.

Step 2. Notation. The first step towards building equations for a mathematical model is an introduction of notation. In this case the data involve time and bacterial density, and it is easy to let t denote time and B_t denote bacterial density at time t . However, the data was read in multiples of 16 minutes, and it will help our notation to rescale time so that t is 0, 1, 2, 3, 4, or 5. Thus B_3 is the bacterial density at time $3 \times 16 = 48$ minutes. The rescaled time is shown under ‘Time Index’ in Table 1.1.

Step 3. Derive a dynamic equation. In some cases your mathematical model will be sufficiently explicit that you are able to write the dynamic equation directly from the model. For this development, we first look at supplemental computations and graphs of the data.

Step 3a. Computation of rates of change from the data. Table 1.1 contains a computed column, ‘Population Change per Unit Time’. In the Mathematical Model, the time for a cell to mature and divide is approximately constant, and the overall population change per unit time should provide useful information.

Explore 1.1.1 Do this. It is important. Suppose the time for a cell to mature and divide is τ minutes. What fraction of the cells should divide each minute? ■

Using our notation,

$$B_0 = 0.022, \quad B_1 = 0.036, \quad B_2 = 0.060, \quad \text{etc.}$$

and

$$B_1 - B_0 = 0.014, \quad B_2 - B_1 = 0.024, \quad \text{etc.}$$

Step 3b. Graphs of the Data. Another important step in modeling is to obtain a visual image of the data. Shown in Figure 1.2 are three graphs that illustrate bacterial growth. Bacterial Growth A is a plot of column 3 vs column 2, B is a plot of column 4 vs column 2, and C is a plot of column 4 vs column 3 from the Table 1.1.

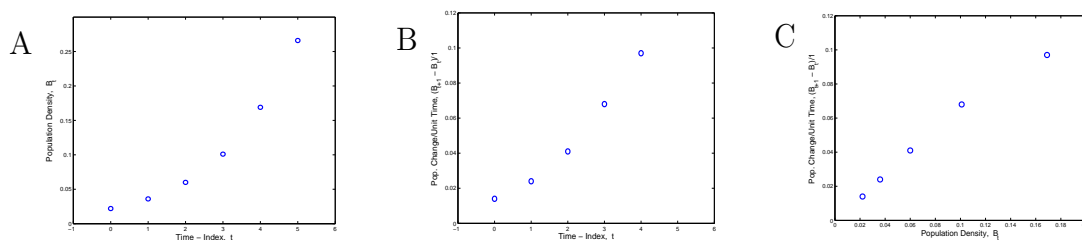

Figure 1.2: (A) Bacterial population density, B_t , vs time index, t . (B) Population density change per unit time, $B_{t+1} - B_t$, vs time index, t . (C) Population density change per unit time, $B_{t+1} - B_t$, vs population density, B_t .

Note: In plotting data, the expression ‘plot B vs A ’ means that B is the vertical coordinate and A is the horizontal coordinate. Students sometimes reverse the axes, and disrupt a commonly used convention that began some 350 years ago. In plotting bacterial density vs time, students may put bacterial density on the horizontal axis and time on the vertical axis, contrary to widely used practice. Perhaps if the mathematician who introduced analytic geometry, Rene DesCartes of France and Belgium, had lived in China where documents are read from top to bottom by columns and from right to left, plotting of data would follow another convention.

We suggest that you use the established convention.

The graph Bacterial Growth A is a classic picture of low density growth with the graph curving upward indicating an increasing growth rate. Observe from Bacterial Growth B that the *rate* of growth (column 4, vertical scale) is increasing with time.

The graph Bacterial Growth C is an important graph for us, for it relates the bacterial increase to bacterial density, and bacterial increase is based on the cell division described in our mathematical model. Because the points lie approximately on a straight line it is easy to get an equation descriptive of this relation. **Note: See Explore 1.1.1.**

Step 3c. An Equation Descriptive of the Data. Shown in Figure 1.3 is a reproduction of the graph Bacterial Growth C in which the point (0.15,0.1) is marked with an ‘+’ and a line is drawn through (0,0) and (0.15,0.1). The slope of the line is $2/3$. The line is ‘fit by eye’ to the first four points. The line can be ‘fit’ more quantitatively, but it is not necessary to do so at this stage.

Explore 1.1.2 Do this. A. Why should the line in Figure 1.3 pass through (0,0)?

B. Suppose the slope of the line is $2/3$. Estimate the time required for a cell to mature and divide. ■

The fifth point, which is $(B_4, B_5 - B_4) = (0.169, 0.097)$ lies below the line. Because the line is so close to the first four points, there is a suggestion that during the fourth time period, the growth, $B_5 - B_4 = 0.097$, is below expectation, or perhaps, $B_5 = 0.266$ is a measurement error and should be larger. These bacteria were actually grown and measured for 160 minutes and we will find in Volume II, Chapter 14 that the measured value $B_5 = 0.266$ is consistent with the remaining data. The bacterial growth is slowing down after $t = 4$, or after 64 minutes.

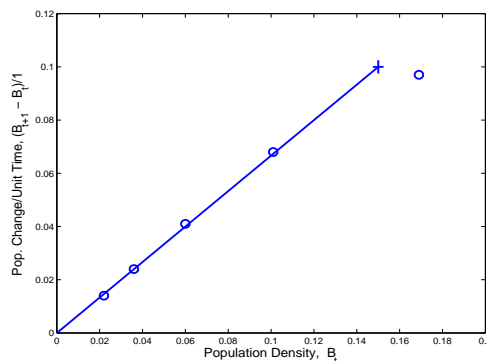

Figure 1.3: A line fit to the first four data points of bacterial growth. The line contains $(0,0)$ and $(0.15, 0.1)$ and has slope $= 2/3$.

The slope of the line in Bacterial Growth C is $\frac{0.1}{0.15} = \frac{2}{3}$ and the y -intercept is 0. Therefore an equation of the line is

$$y = \frac{2}{3}x$$

Step 3d. Convert data equation to a dynamic equation. The points in Bacterial Growth C were plotted by letting $x = B_t$ and $y = B_{t+1} - B_t$ for $t = 0, 1, 2, 3$, and 4. If we substitute for x and y into the data equation $y = \frac{2}{3}x$ we get

$$B_{t+1} - B_t = \frac{2}{3}B_t \quad (1.1)$$

Equation 1.1 is our first instance of a dynamic equation descriptive of a biological process.

Step 4. Enhance the preliminary mathematical model of Step 1. The preliminary mathematical model in Step 1 describes microscopic cell division and can be expanded to describe the macroscopic cell density that was observed in the experiment. One might extrapolate from the original statement, but the observed data guides the development.

In words Equation 1.1 says that the growth during the t -th time interval is $\frac{2}{3}$ times B_t , the bacteria present at time t , the beginning of the period. The number $\frac{2}{3}$ is called the *relative growth rate* - the growth per time interval is two-thirds of the current population size. More generally, one may say:

Mathematical Model 1.1.1 Bacterial Growth. A fixed fraction of cells divide every time period. (In this instance, two-thirds of the cells divide every 16 minutes.)

Step 5. Compute a solution to the dynamic equation. We first compute estimates of B_1 and B_2 predicted by the dynamic equation. The dynamic equation 1.1 specifies the change in bacterial density ($B_{t+1} - B_t$) from t to time $t + 1$. In order to be useful, an initial value of B_0 is required. We assume the original data point, $B_0 = 0.022$ as our reference point. It will be convenient to change $B_{t+1} - B_t = \frac{2}{3}B_t$ into what we call an **iteration** equation:

$$B_{t+1} - B_t = \frac{2}{3}B_t \quad B_{t+1} = \frac{5}{3}B_t \quad (1.2)$$

Iteration Equation 1.2 is shorthand for at least five equations

$$B_1 = \frac{5}{3}B_0, \quad B_2 = \frac{5}{3}B_1, \quad B_3 = \frac{5}{3}B_2, \quad B_4 = \frac{5}{3}B_3, \quad \text{and} \quad B_5 = \frac{5}{3}B_4.$$

Beginning with $B_0 = 0.022$ we can compute

$$B_1 = \frac{5}{3} B_0 = \frac{5}{3} 0.022 = 0.037$$

$$B_2 = \frac{5}{3} B_1 = \frac{5}{3} 0.037 = 0.061$$

Explore 1.1.3 Use $B_0 = 0.022$ and $B_{t+1} = \frac{5}{3} B_t$ to compute $B_1, B_2, B_3, B_4,$ and B_5 . ■

There is also some important notation used to describe the values of B_t determined by the iteration $B_{t+1} = \frac{5}{3} B_t$. We can write

$$B_1 = \frac{5}{3} B_0$$

$$B_2 = \frac{5}{3} B_1 \quad B_2 = \frac{5}{3} \left(\frac{5}{3} B_0 \right) = \frac{5}{3} \frac{5}{3} B_0$$

$$B_3 = \frac{5}{3} B_2 \quad B_3 = \frac{5}{3} \left(\frac{5}{3} \frac{5}{3} B_0 \right) = \frac{5}{3} \frac{5}{3} \frac{5}{3} B_0$$

Explore 1.1.4 Write an equation for B_4 in terms of B_0 , using the pattern of the last equations. ■

At time interval 5, we get

$$B_5 = \frac{5}{3} \frac{5}{3} \frac{5}{3} \frac{5}{3} \frac{5}{3} B_0$$

which is cumbersome and is usually written

$$B_5 = \left(\frac{5}{3} \right)^5 B_0.$$

The general form is

$$B_t = \left(\frac{5}{3} \right)^t B_0 = B_0 \left(\frac{5}{3} \right)^t \quad (1.3)$$

Using the starting population density, $B_0 = 0.022$, Equation 1.3 becomes

$$B_t = 0.022 \left(\frac{5}{3} \right)^t \quad (1.4)$$

and is the *solution* to the initial condition and dynamic equation 1.1

$$B_0 = 0.022, \quad B_{t+1} - B_t = \frac{2}{3} B_t$$

Populations whose growth is described by an equation of the form

$$P_t = P_0 R^t \quad \text{with} \quad R > 1$$

are said to exhibit *exponential growth*.

Equation 1.4 is written in terms of the time index, t . In terms of time, T in minutes, $T = 16t$ and Equation 1.4 may be written

$$B_T = 0.022 \left(\frac{5}{3} \right)^{T/16} = 0.022 1.032^T \quad (1.5)$$

Step 6. Compare predictions from the Mathematical Model with the original data.

How well did we do? That is, how well do the computed values of bacterial density, B_t , match the observed values? The original and computed values are shown in Figure 1.4.

pH 6.25			
Time (min)	Time Index	Population Density	Computed Density
0	0	0.022	0.022
16	1	0.036	0.037
32	2	0.060	0.061
48	3	0.101	0.102
64	4	0.169	0.170
80	5	0.266	0.283

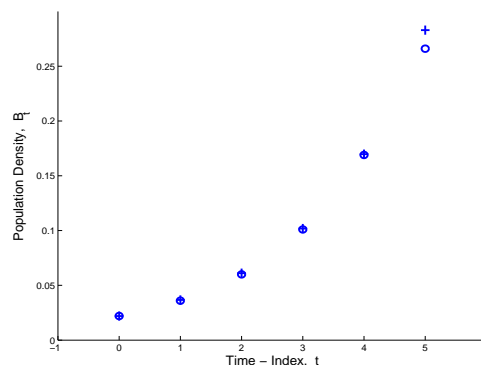

Figure 1.4: Tabular and graphical comparison of actual bacterial densities (o) with bacterial densities computed from Equation 1.3 (+).

The computed values match the observed values closely except for the last measurement where the observed value is less than the value predicted from the mathematical model. The effect of cell crowding or environmental contamination or age of cells is beginning to appear after an hour of the experiment and the model does not take this into account. We will return to this population with data for the next 80 minutes of growth in Section 15.6.1 and will develop a new model that will account for decreasing rate of growth as the population size increases.

1.1.2 Concerning the validity of a model.

We have used the population model once and found that it matches the data rather well. The validity of a model, however, is only established after multiple uses in many laboratories and critical examination of the forces and interactions that lead to the model equations. Models evolve as knowledge accumulates. Mankind's model of the universe has evolved from the belief that Earth is the center of the universe, to the Copernican model that the sun is the center of the universe, to the realization that the sun is but a single star among some 200 billion in a galaxy, to the surprisingly recent realization (Hubble, 1923) that our Milky Way galaxy is but a single galaxy among an enormous universe of galaxies.

It is fortunate that our solution equation matched the data, but it must be acknowledged that two crucial parameters, P_0 and r , were computed from the data, so that a fit may not be a great surprise. Other equations also match the data. The parabola, $y = 0.0236 + .000186t + 0.00893t^2$, computed by least squares fit to the first five data points is shown in Figure 1.5, and it matches the data as well as does $P_t = 0.022(5/3)^t$. We prefer $P_t = 0.022(5/3)^t$ as an explanation of the data over the parabola obtained by the method of least squares because it is derived from an understanding of bacterial growth as described by the model whereas the parabolic equation is simply a match of equation to data.

Exercises for Section 1.1, Experimental data, bacterial growth

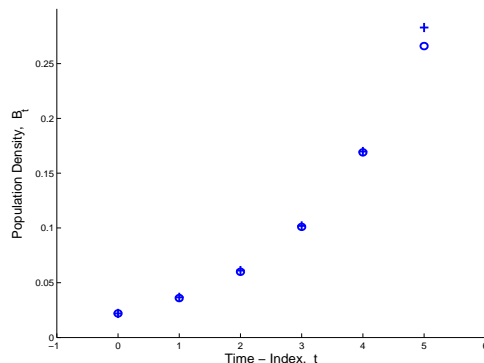

Figure 1.5: A graph of $y = 0.0236 + .000186t + 0.00893t^2$ (+) which is the quadratic fit by least squares to the first six data points (o) of *V. natriegens* growth in Table 1.1

Exercise 1.1.1 Compute B_1 , B_2 , and B_3 as in Step 5 of this section for

- a. $B_0 = 4$ $B_{t+1} - B_t = 0.5 B_t$
- b. $B_0 = 4$ $B_{t+1} - B_t = 0.1 B_t$
- c. $B_0 = 0.2$ $B_{t+1} - B_t = 0.05 B_t$
- d. $B_0 = 0.2$ $B_{t+1} - B_t = 1 B_t$
- e. $B_0 = 100$ $B_{t+1} - B_t = 0.4 B_t$
- f. $B_0 = 100$ $B_{t+1} - B_t = 0.01 B_t$

Exercise 1.1.2 Write a solution equation for the initial conditions and dynamic equations of Exercise 1.1.1 similar to the solution Equation 1.4, $B_t = (5/3)^t 0.022$ of the pair $B_0 = 0.022$, $B_{t+1} - B_t = (2/3)B_t$.

Exercise 1.1.3 Observe that the graph Bacterial Growth C is a plot of $B_{t+1} - B_t$ vs B_t . The points are $(B_0, B_1 - B_0)$, $(B_1, B_2 - B_1)$, etc. The second coordinate, $B_{t+1} - B_t$ is the population increase during time period t , given that the population at the beginning of the time period is B_t . Explain why the point $(0,0)$ would be a point of this graph.

Exercise 1.1.4 In Table 1.2 are given four sets of data. For each data set, find a number r so that the values B_1, B_2, B_3, B_4, B_5 and B_6 computed from the difference equation

$$B_0 = \text{as given in the table,} \quad B_{t+1} - B_t = r B_t$$

are close to the corresponding numbers in the table. Compute the numbers, B_1 to B_6 using your value of r in the equation, $B_{t+1} = (1 + r) B_t$, and compare your computed numbers with the original data.

For each data set, follow steps 3, 5, and 6. The line you draw close to the data in step 3 should go through $(0,0)$.

Exercise 1.1.5 The bacterium *V. natriegens* was also grown in a growth medium with pH of 7.85. Data for that experiment is shown in Table 1.3. Repeat the analysis in steps 1 - 9 of this section for this data. After completing the steps 1 - 9, compare your computed relative growth rate of *V. natriegens* at pH 7.85 with our computed relative growth rate of $2/3$ at pH 6.25.

Exercise 1.1.6 What initial condition and dynamic equation would describe the growth of an *Escherichia coli* population in a nutrient medium that had 250,000 *E. coli* cells per milliliter at the start of an experiment and one-fourth of the cells divided every 30 minutes.

Table 1.2: Tables of data for Exercise 1.1.4

(a)	(b)	(c)	(d)																																																																
<table border="1" style="border-collapse: collapse; width: 80px;"> <tr><th>t</th><th>B_t</th></tr> <tr><td>0</td><td>1.99</td></tr> <tr><td>1</td><td>2.68</td></tr> <tr><td>2</td><td>3.63</td></tr> <tr><td>3</td><td>4.89</td></tr> <tr><td>4</td><td>6.63</td></tr> <tr><td>5</td><td>8.93</td></tr> <tr><td>6</td><td>12.10</td></tr> </table>	t	B_t	0	1.99	1	2.68	2	3.63	3	4.89	4	6.63	5	8.93	6	12.10	<table border="1" style="border-collapse: collapse; width: 80px;"> <tr><th>t</th><th>B_t</th></tr> <tr><td>0</td><td>0.015</td></tr> <tr><td>1</td><td>0.021</td></tr> <tr><td>2</td><td>0.031</td></tr> <tr><td>3</td><td>0.040</td></tr> <tr><td>4</td><td>0.055</td></tr> <tr><td>5</td><td>0.075</td></tr> <tr><td>6</td><td>0.106</td></tr> </table>	t	B_t	0	0.015	1	0.021	2	0.031	3	0.040	4	0.055	5	0.075	6	0.106	<table border="1" style="border-collapse: collapse; width: 80px;"> <tr><th>t</th><th>B_t</th></tr> <tr><td>0</td><td>22.1</td></tr> <tr><td>1</td><td>23.4</td></tr> <tr><td>2</td><td>26.1</td></tr> <tr><td>3</td><td>27.5</td></tr> <tr><td>4</td><td>30.5</td></tr> <tr><td>5</td><td>34.4</td></tr> <tr><td>6</td><td>36.6</td></tr> </table>	t	B_t	0	22.1	1	23.4	2	26.1	3	27.5	4	30.5	5	34.4	6	36.6	<table border="1" style="border-collapse: collapse; width: 80px;"> <tr><th>t</th><th>B_t</th></tr> <tr><td>0</td><td>287</td></tr> <tr><td>1</td><td>331</td></tr> <tr><td>2</td><td>375</td></tr> <tr><td>3</td><td>450</td></tr> <tr><td>4</td><td>534</td></tr> <tr><td>5</td><td>619</td></tr> <tr><td>6</td><td>718</td></tr> </table>	t	B_t	0	287	1	331	2	375	3	450	4	534	5	619	6	718
t	B_t																																																																		
0	1.99																																																																		
1	2.68																																																																		
2	3.63																																																																		
3	4.89																																																																		
4	6.63																																																																		
5	8.93																																																																		
6	12.10																																																																		
t	B_t																																																																		
0	0.015																																																																		
1	0.021																																																																		
2	0.031																																																																		
3	0.040																																																																		
4	0.055																																																																		
5	0.075																																																																		
6	0.106																																																																		
t	B_t																																																																		
0	22.1																																																																		
1	23.4																																																																		
2	26.1																																																																		
3	27.5																																																																		
4	30.5																																																																		
5	34.4																																																																		
6	36.6																																																																		
t	B_t																																																																		
0	287																																																																		
1	331																																																																		
2	375																																																																		
3	450																																																																		
4	534																																																																		
5	619																																																																		
6	718																																																																		

Table 1.3: Data for Exercise 1.1.5, *V. natriegens* growth in a medium with pH of 7.85.

pH 7.85	
Time (min)	Population Density
0	0.028
16	0.047
32	0.082
48	0.141
64	0.240
80	0.381

1.2 Solution to the dynamic equation $P_{t+1} - P_t = r P_t$.

The dynamic equation with initial condition, P_0 ,

$$P_{t+1} - P_t = r P_t, \quad t = 0, 1, \dots, \quad P_0 \text{ a known value} \tag{1.6}$$

arises in many models of elementary biological processes. A *solution* to the dynamic equation 1.6 is a formula for computing P_t in terms of t and P_0 .

Assume that $r \neq 0$ and $P_0 \neq 0$. The equation $P_{t+1} - P_t = r P_t$ can be changed to iteration form by

$$\begin{aligned} P_{t+1} - P_t &= r P_t \\ P_{t+1} &= (r + 1) P_t \\ P_{t+1} &= R P_t \end{aligned} \tag{1.7}$$

where $R = r + 1$. The equation $P_{t+1} = R P_t$ is valid for $t = 0, t = 1, \dots$ and represents a large

number of equations, as in

$$\left. \begin{array}{l} P_1 = R P_0 \quad t = 0 \\ P_2 = R P_1 \quad t = 1 \\ \vdots \quad \vdots \\ P_{n-1} = R P_{n-2} \quad t = n - 2 \\ P_n = R P_{n-1} \quad t = n - 1 \end{array} \right\} \quad (1.8)$$

where n can be any stopping value.

Cascading equations. These equations (1.8) may be ‘cascaded’ as follows.

1. The product of all the numbers on the left sides of Equations 1.8 is equal to the product of all of the numbers on the right sides. Therefore

$$P_1 \times P_2 \times \cdots \times P_{n-1} \times P_n = R P_0 \times R P_1 \times \cdots \times R P_{n-2} \times R P_{n-1}$$

2. The previous equation may be rearranged to

$$P_1 P_2 \cdots P_{n-1} P_n = R^n P_0 P_1 \cdots P_{n-2} P_{n-1}.$$

3. $P_1, P_2, \cdots, P_{n-1}$ are factors on both sides of the equation and (assuming no one of them is zero) may be divided from both sides of the equation, leaving

$$P_n = R^n P_0$$

Because n is arbitrary and the dynamic equation is written with t , we write

$$P_t = R^t P_0 = P_0 (1 + r)^t \quad (1.9)$$

as the solution to the iteration

$$P_{t+1} = R P_t \quad \text{with initial value, } P_0$$

and the solution to

$$P_{t+1} - P_t = r P_t \quad \text{with initial value, } P_0.$$

- Explore 1.2.1** a. Suppose $r = 0$ in $P_{t+1} - P_t = r P_t$ so that $P_{t+1} - P_t = 0$. What are P_1, P_2, \cdots ?
 b. Suppose $P_0 = 0$, and $P_{t+1} - P_t = r P_t$ for $t = 0, 1, 2, \cdots$. What are P_1, P_2, \cdots ? ■

Example 1.2.1 Suppose a human population is growing at 1% per year and initially has 1,000,000 individuals. Let P_t denote the populations size t years after the initial population of $P_0 = 1,000,000$ individuals. If one asks what the population will be in 50 years there are two options.

Option 1. At 1% per year growth, the dynamic equation would be

$$P_{t+1} - P_t = 0.01 P_t$$

and the corresponding iteration equation is

$$P_{t+1} = 1.01 P_t$$

With $P_0 = 1,000,000$, $P_1 = 1.01 \times 1,000,000 = 1,010,000$, $P_2 = 1.01 \cdot 1,010,000 = 1,020,100$ and so on for 50 iterations.

Option 2. Alternatively, one may write the solution

$$P_t = 1.01^t (1,000,000)$$

so that

$$P_{50} = 1.01^{50} (1,000,000) = 1,644,631$$

The algebraic form of the solution, $P_t = R^t P_0$, with $r > 0$ and $R > 1$ is informative and gives rise to the common description of *exponential growth* attached to some populations. If r is negative and $R = 1 + r < 1$, the solution equation $P_t = R^t P_0$ exhibits *exponential decay*.

Exercises for Section 1.2, Solution to the dynamic equation, $P_{t+1} - P_t = rP_t$.

Exercise 1.2.1 Write a solution equation for the following initial conditions and difference equations or iteration equations. In each case, compute B_{100} .

- | | | | |
|----|---------------|-------------------|------------|
| a. | $B_0 = 1,000$ | $B_{t+1} - B_t =$ | $0.2 B_t$ |
| b. | $B_0 = 138$ | $B_{t+1} - B_t =$ | $0.05 B_t$ |
| c. | $B_0 = 138$ | $B_{t+1} - B_t =$ | $0.5 B_t$ |
| d. | $B_0 = 1,000$ | $B_{t+1} - B_t =$ | $-0.2 B_t$ |
| e. | $B_0 = 1,000$ | $B_{t+1} =$ | $1.2 B_t$ |
| f. | $B_0 = 1000$ | $B_{t+1} - B_t =$ | $-0.1 B_t$ |
| e. | $B_0 = 1,000$ | $B_{t+1} =$ | $0.9 B_t$ |

Exercise 1.2.2 The equation, $B_t - B_{t-1} = rB_{t-1}$, carries the same information as $B_{t+1} - B_t = rB_t$.

- a. Write the first four instances of $B_t - B_{t-1} = rB_{t-1}$ using $t = 1, t = 2, t = 3$, and $t = 4$.
- b. Cascade these four equations to get an expression for B_4 in terms of r and B_0 .
- c. Write solutions to and compute B_{40} for

- | | | | |
|------|------------|-------------------|----------------|
| (a.) | $B_0 = 50$ | $B_t - B_{t-1} =$ | $0.2 B_{t-1}$ |
| (b.) | $B_0 = 50$ | $B_t - B_{t-1} =$ | $0.1 B_{t-1}$ |
| (c.) | $B_0 = 50$ | $B_t - B_{t-1} =$ | $0.05 B_{t-1}$ |
| (d.) | $B_0 = 50$ | $B_t - B_{t-1} =$ | $-0.1 B_{t-1}$ |

Exercise 1.2.3 Suppose a population is initially of size 1,000,000 and grows at the rate of 2% per year. What will be the size of the population after 50 years?

Exercise 1.2.4 The polymerase chain reaction is a means of making multiple copies of a DNA segment from only a minute amounts of original DNA. The procedure consists of a sequence of, say, 30 cycles in which each segment present at the beginning of a cycle is duplicated once; at the end of the cycle that segment and one copy is present. Introduce notation and write a difference equation with initial condition from which the amount of DNA present at the end of each cycle can be computed. Suppose you begin with 1 picogram = 0.000000000001 g of DNA. How many grams of DNA would be present after 30 cycles.

Exercise 1.2.5 Write a solution to the dynamic equation you obtained for growth of *V. natriegens* in growth medium of pH 7.85 in Exercise 1.1.5. Use your solution to compute your estimate of B_4 .

Exercise 1.2.6 There is a suggestion that the world human population is growing exponentially. Shown below are the human population numbers in billions of people for the decades 1940 - 2010.

Year	1940	1950	1960	1970	1980	1990	2000	2010
Index, t	0	1	2	3	4	5	6	7
Human Population $\times 10^6$	2.30	2.52	3.02	3.70	4.45	5.30	6.06	6.80

1. Test the equation

$$P_t = 2.2 \cdot 1.19^t$$

against the data where t is the time index in decades after 1940 and P_t is the human population in billions.

2. What percentage increase in human population each decade does the model for the equation assume?
3. What world human population does the equation predict for the year 2050?

1.3 Experimental data: Sunlight depletion below the surface of a lake or ocean.

Light extinction with increasing depth of water determines underwater plant, algae, and phytoplankton growth and thus has important biological consequences. We develop and analyze a mathematical model of light extinction below the surface of the ocean.

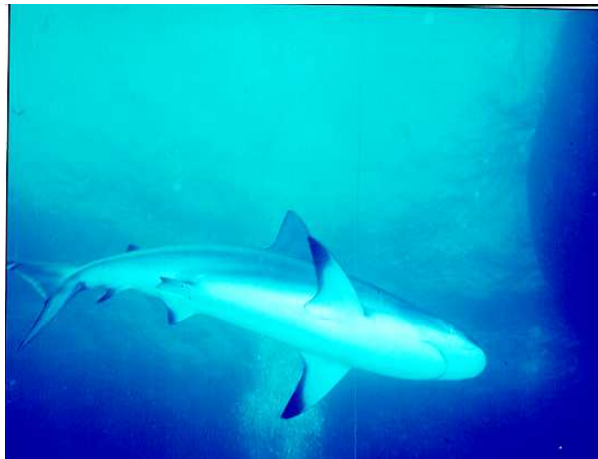

Figure 1.6: There is less light in the water below the shark than there is in the water above the shark.

Sunlight is the energy source of almost all life on Earth and its penetration into oceans and lakes largely determines the depths at which plant, algae and phytoplankton life can persist. This life is important to us: some 85% of all oxygen production on earth is by the phytoplankta diatoms and dinoflagellates⁴.

⁴PADI Diving Encyclopedia

Explore 1.3.1 Preliminary analysis. Even in a very clear ocean, light decreases with depth below the surface, as illustrated in Figure 1.6. Think about how light would decrease if you were to descend into the ocean. Light that reaches you passes through the water column above you.

- a. Suppose the light intensity at the ocean surface is I_0 and at depth 10 meters the light intensity is $\frac{1}{2}I_0$. What light intensity would you expect at 20 meters?
- b. Draw a candidate graph of light intensity versus depth.

We are asking you to essentially follow the bold arrows of the chart in Figure 1.7. ■

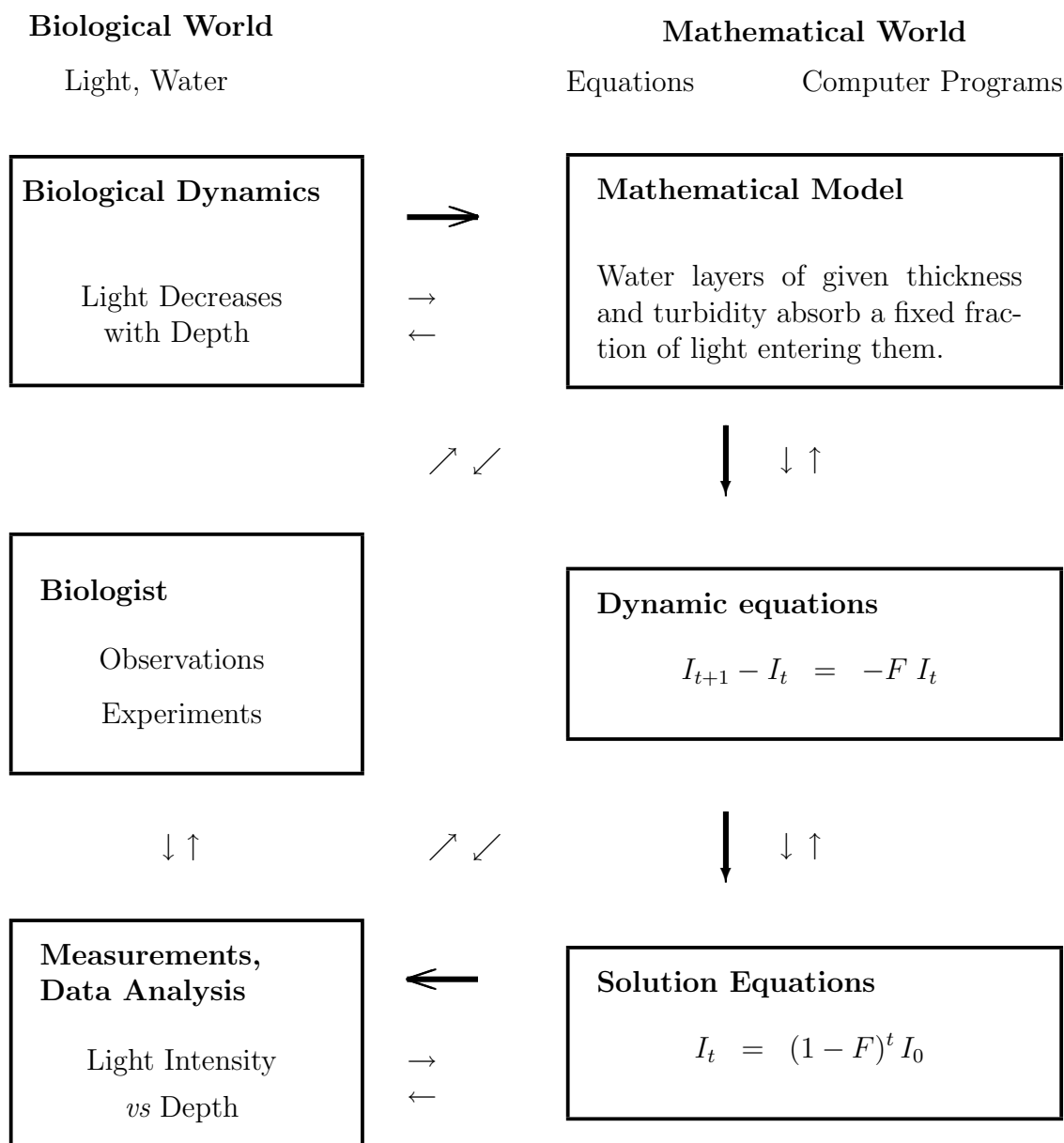

Figure 1.7: Biology - Mathematics: Information Flow Chart for the sunlight depletion example.

The steps in the analysis of light depletion are analogous to the steps for the analysis of bacterial growth in Section 1.1.

Step 1. Statement of a mathematical model. Think of the ocean as divided into layers, say one meter thick, as illustrated in Figure 1.8. As light travels downward from the surface, each layer will absorb some light. We will assume that the distribution of suspended particles in the water is uniform so that the light absorbing properties of each two layers are the same. We hypothesize that each two layers will absorb the same *fraction* of the light that enters it. The magnitude of the light absorbed will be greater in the top layers than in the lower layers simply because the intensity of the light entering the the top layers is greater than the intensity of light at the lower layers. We state the hypothesis as a mathematical model.

Mathematical Model 1.3.1 Light depletion with depth of water. Each layer absorbs a fraction of the light entering the layer from above. The *fraction of light absorbed*, f , is the same for all layers of a fixed thickness.

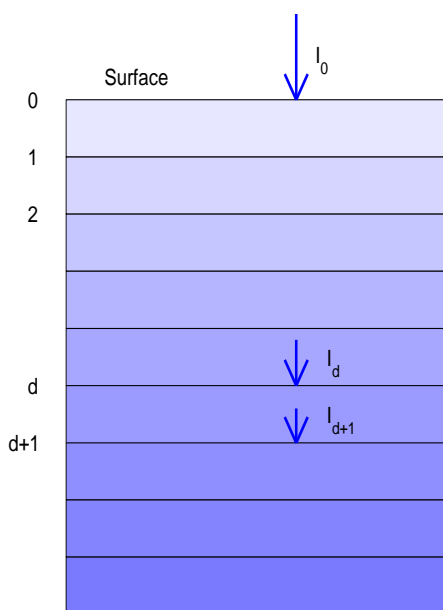

Figure 1.8: A model of the ocean partitioned into layers.

Step 2. Notation We will let d denote depth (an index measured in layers) and I_d denote light intensity at depth d . Sunlight is partly reflected by the surface, and I_0 (light intensity at depth 0) is to be the intensity of the light that penetrates the surface. I_1 is the light intensity at the bottom of the first layer, and at the top of the second layer.

The *opacity*⁵ of the water is due generally to suspended particles and is a measure of the *turbidity* of the water. In relatively clear ocean water, atomic interaction with light is largely responsible for light decay. In the bacterial experiments, the growth of the bacteria increases the turbidity of the growth serum, thus increasing the opacity and the absorbance.

The fraction, f , of light absorbed by each layer is between 0 and 1 (or possibly 1, which would not be a very interesting model). Although f is assumed to be the same for all layers, the value of f depends on the thickness of the layer and the distribution of suspended particles in the water and atomic interactions with light. Approximately,

$$f = \text{Layer thickness} \times \text{Opacity of the water.}$$

⁵Wikipedia. Opacity – the degree to which light is not allowed to travel through. Turbidity– the cloudiness or haziness of a fluid caused by individual particles (suspended particles) that are generally invisible to the naked eye.

Layer thickness should be sufficiently thin that the preceding approximation yields a value of f substantially less than 1. We are developing a discrete model of continuous process, and need layers thin enough to give a good approximation. The continuous model is shown in Subsection 5.5.2. Thus for high opacity of a muddy lake, layer thickness of 20 cm might be required, but for a sparkling ocean, layer thickness of 10 m might be acceptable.

Explore 1.3.2 Assume that at the surface light intensity I_0 is 400 watts/meter-squared and that each layer of thickness 2 meters absorbs 10% of the light that enters it. Calculate the light intensity at depths 2, 4, 6, \dots , 20 meters. Plot your data and compare your graph with the graph you drew in Explore 1.3.1. ■

Step 3. Develop a dynamic equation representative of the model. Consider the layer between depths d and $d + 1$ in Figure 1.8. The intensity of the light entering the layer is I_d .

The light absorbed by the layer between depths d and $d + 1$ is the difference between the light entering the layer at depth d and the light leaving the layer at depth $d + 1$, which is $I_d - I_{d+1}$.

The mathematical model asserts that

$$I_d - I_{d+1} = f I_d \quad (1.10)$$

Note that I_d decreases as d increases so that both sides of equation 1.10 are positive. It is more common to write

$$I_{d+1} - I_d = -f I_d \quad (1.11)$$

and to put this equation in iteration form

$$I_{d+1} = (1 - f) I_d \quad I_{d+1} = F I_d \quad (1.12)$$

where $F = 1 - f$. Because $0 < f < 1$, also $0 < F < 1$.

Step 4. Enhance the mathematical model of Step 1. We are satisfied with the model of Step 1 (have not yet looked at any real data!), and do not need to make an adjustment.

Step 5. Solve the dynamical equation, $I_{d+1} - I_d = -f I_d$. The iteration form of the dynamical equation is $I_{d+1} = F I_d$ and is similar to the iteration equation $B_{t+1} = \frac{5}{3} B_t$ of bacterial growth for which the solution is $B_t = B_0 \left(\frac{5}{3}\right)^t$. We conclude that the solution of the light equation is

$$I_d = I_0 F^d \quad (1.13)$$

The solutions,

$$B_t = B_0 \left(\frac{5}{3}\right)^t \quad \text{and} \quad I_d = I_0 F^d \quad F < 1$$

are quite different in character, however, because $\frac{5}{3} > 1$, $\left(\frac{5}{3}\right)^t$ increases with increasing t and for $F < 1$, F^d decreases with increasing d .

Step 6. Compare predictions from the model with experimental data. It is time we looked at some data. We present some data, estimate f of the model from the data, and compare values computed from Equation 1.13 with observed data.

In measuring light extinction, it is easier to bring the water into a laboratory than to make measurements in a lake, and our students have done that. Students collected water from a campus lake with substantial suspended particulate matter (that is, yucky). A vertically oriented 3 foot section of 1.5 inch diameter PVC pipe was blocked at the bottom end with a clear plastic plate and a flashlight was shined into the top of the tube (see Figure 1.9). A light detector was placed below the clear plastic at the bottom of the tube. Repeatedly, 30 cm³ of lake water was inserted into the tube and the light intensity at the bottom of the tube was measured. One such data set is given in Figure 1.9⁶.

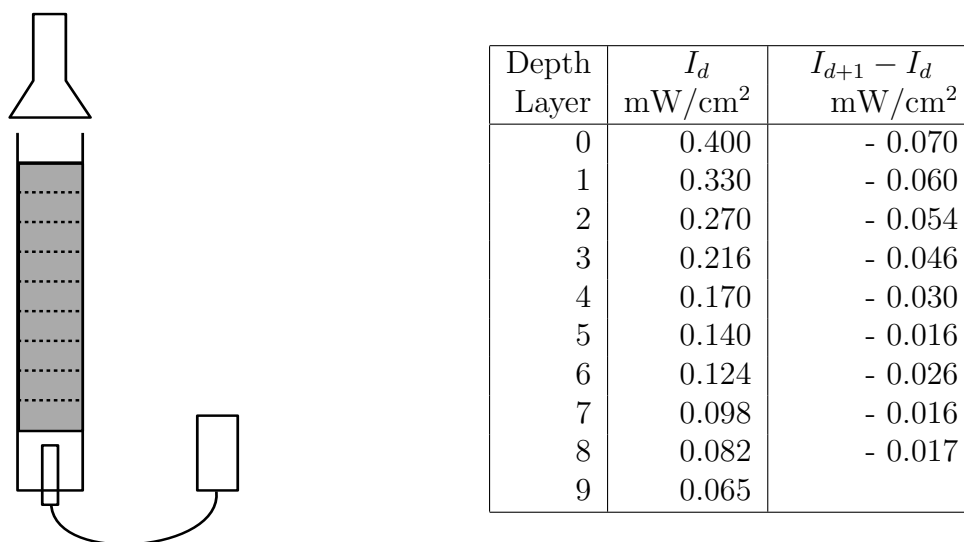

Figure 1.9: Diagram of laboratory equipment and data obtained from a light decay experiment.

Explore 1.3.3 In Figure 1.10A is a graph of I_d vs d . Compare this graph with the two that you drew in Explore 1.3.1 and 1.3.2. ■

Our dynamical equation relates $I_{d+1} - I_d$ to I_d and we compute change in intensity, $I_{d+1} - I_d$, just as we computed changes in bacterial population. The change in intensity, $I_{d+1} - I_d$, is the amount of light absorbed by layer, d .

Graphs of the data. A graph of the original data, I_d vs d , is shown in Figure 1.10(A) and a graph of $I_{d+1} - I_d$ vs I_d is shown in Figure 1.10(B).

In Figure 1.10(B) we have drawn a line close to the data that passes through (0,0). Our reason that the line should contain (0,0) is that if I_d , the amount of light entering layer d is small, then $I_{d+1} - I_d$, the amount of light absorbed by that layer is also small. Therefore, for additional layers, the data will cluster near (0,0).

The graph of $I_{d+1} - I_d$ vs I_d is a scattered in its upper portion, corresponding to low light intensities. There are two reasons for this.

1. Maintaining a constant light source during the experiment is difficult so that there is some error in the data.

⁶This laboratory is described in Brian A. Keller, Shedding light on the subject, *Mathematics Teacher* **91** (1998), 756-771.

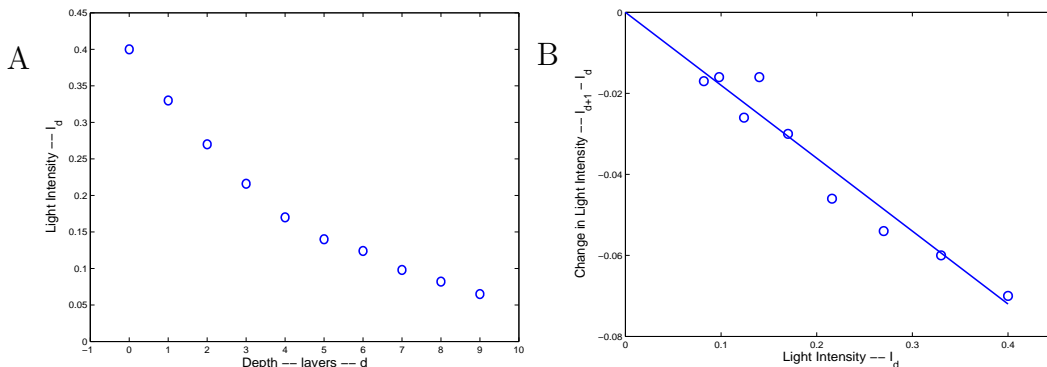

Figure 1.10: (A) The light decay curve for the data of Figure 1.9 and (B) the graph of light absorbed by layers *vs* light entering the layer from Table 1.9.

2. *Subtraction of numbers that are almost equal emphasizes the error*, and in some cases the error can be as large as the difference you wish to measure. In the lower depths, the light values are all small and therefore nearly equal so that the error in the differences is a large percentage of the computed differences.

Use the data to develop a dynamic equation. The line goes through (0,0) and the point (0.4, -0.072). An equation of the line is

$$y = -0.18x$$

Remember that y is $I_{d+1} - I_d$ and x is I_d and substitute to get

$$I_{d+1} - I_d = -0.18 I_d \tag{1.14}$$

This is the dynamic Equation 1.11 with $-f = -0.18$.

Solve the dynamic equation. (Step 5 for this data.) The iteration form of the dynamic equation is

$$I_{d+1} = I_d - 0.18I_d \qquad I_{d+1} = 0.82 I_d$$

and the solution is (with $I_0 = 0.400$)

$$I_d = 0.82^d I_0 = 0.400 0.82^d \tag{1.15}$$

Compare predictions from the Mathematical Model with the original data. How well did we do? Again we use the equations of the model to compute values and compare them with the original data. Shown in Figure 1.11 are the original data and data computed with $\hat{I}_d = 0.400 0.82^d$, and a graph comparing them.

The computed data match the observed data quite well, despite the ‘fuzziness’ of the graph in Figure 1.10(b) of $I_{d+1} - I_d$ *vs* I_d from which the dynamic equation was obtained.

Exercises for Section 1.3, Experimental data: Sunlight depletion below the surface of a lake or ocean.

Depth Layer	I_d Observed	\hat{I}_d Computed
0	0.400	0.400
1	0.330	0.328
2	0.270	0.269
3	0.216	0.221
4	0.170	0.181
5	0.140	0.148
6	0.124	0.122
7	0.098	0.100
8	0.082	0.082
9	0.065	0.067

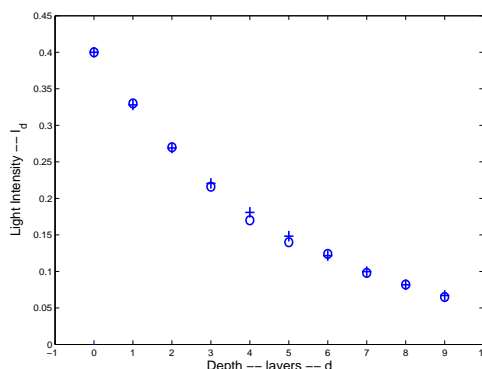

Figure 1.11: Comparison of original light intensities (o) with those computed from $\hat{I}_d = 0.82^d 0.400$ (+).

Exercise 1.3.1 In Table 1.4 are given four sets of data that mimic light decay with depth. For each data set, find a number r so that the values B_1, B_2, B_3, B_4, B_5 and B_6 computed from the difference equation

$$B_0 = \text{as given in the table,} \quad B_{t+1} - B_t = -r B_t$$

are close to the corresponding numbers in the table. Compute the numbers, B_1 to B_6 using your value of R in the equation and compare your computed numbers with the original data.

For each data set, follow steps 3, 5, and 6. The line you draw close to the data in step 3 should go through (0,0).

Table 1.4: Tables of data for Exercise 1.3.1

(a)	(b)	(c)	(d)																																																																
<table border="1" style="margin: auto;"> <thead> <tr><th>t</th><th>B_t</th></tr> </thead> <tbody> <tr><td>0</td><td>3.01</td></tr> <tr><td>1</td><td>2.55</td></tr> <tr><td>2</td><td>2.14</td></tr> <tr><td>3</td><td>1.82</td></tr> <tr><td>4</td><td>1.48</td></tr> <tr><td>5</td><td>1.22</td></tr> <tr><td>6</td><td>1.03</td></tr> </tbody> </table>	t	B_t	0	3.01	1	2.55	2	2.14	3	1.82	4	1.48	5	1.22	6	1.03	<table border="1" style="margin: auto;"> <thead> <tr><th>t</th><th>B_t</th></tr> </thead> <tbody> <tr><td>0</td><td>20.0</td></tr> <tr><td>1</td><td>10.9</td></tr> <tr><td>2</td><td>5.7</td></tr> <tr><td>3</td><td>3.1</td></tr> <tr><td>4</td><td>1.7</td></tr> <tr><td>5</td><td>0.9</td></tr> <tr><td>6</td><td>0.5</td></tr> </tbody> </table>	t	B_t	0	20.0	1	10.9	2	5.7	3	3.1	4	1.7	5	0.9	6	0.5	<table border="1" style="margin: auto;"> <thead> <tr><th>t</th><th>B_t</th></tr> </thead> <tbody> <tr><td>0</td><td>521</td></tr> <tr><td>1</td><td>317</td></tr> <tr><td>2</td><td>189</td></tr> <tr><td>3</td><td>119</td></tr> <tr><td>4</td><td>75</td></tr> <tr><td>5</td><td>45</td></tr> <tr><td>6</td><td>28</td></tr> </tbody> </table>	t	B_t	0	521	1	317	2	189	3	119	4	75	5	45	6	28	<table border="1" style="margin: auto;"> <thead> <tr><th>t</th><th>B_t</th></tr> </thead> <tbody> <tr><td>0</td><td>0.85</td></tr> <tr><td>1</td><td>0.65</td></tr> <tr><td>2</td><td>0.51</td></tr> <tr><td>3</td><td>0.40</td></tr> <tr><td>4</td><td>0.32</td></tr> <tr><td>5</td><td>0.25</td></tr> <tr><td>6</td><td>0.19</td></tr> </tbody> </table>	t	B_t	0	0.85	1	0.65	2	0.51	3	0.40	4	0.32	5	0.25	6	0.19
t	B_t																																																																		
0	3.01																																																																		
1	2.55																																																																		
2	2.14																																																																		
3	1.82																																																																		
4	1.48																																																																		
5	1.22																																																																		
6	1.03																																																																		
t	B_t																																																																		
0	20.0																																																																		
1	10.9																																																																		
2	5.7																																																																		
3	3.1																																																																		
4	1.7																																																																		
5	0.9																																																																		
6	0.5																																																																		
t	B_t																																																																		
0	521																																																																		
1	317																																																																		
2	189																																																																		
3	119																																																																		
4	75																																																																		
5	45																																																																		
6	28																																																																		
t	B_t																																																																		
0	0.85																																																																		
1	0.65																																																																		
2	0.51																																																																		
3	0.40																																																																		
4	0.32																																																																		
5	0.25																																																																		
6	0.19																																																																		

Exercise 1.3.2 Now it is your turn. Shown in the Exercise Table 1.3.2 are data from a light experiment using the laboratory procedure of this section. The only difference is the water that was used. Plot the data, compute differences and obtain a dynamic equation from the plot of differences *vs* intensities. Solve the dynamic equation and compute estimated values from the

intensities and compare them with the observed light intensities. Finally, decide whether the water from your experiment is more clear or less clear than the water in Figure 1.9. (Note: Layer thickness was the same in both experiments.)

Table for Exercise 1.3.2 Data for Exercise 1.3.2.

Depth Layer	0	1	2	3	4	5	6	7	8
Light Intensity	0.842	0.639	0.459	0.348	0.263	0.202	.154	0.114	0.085

Exercise 1.3.3 One might reasonably conclude that the graph in Figure 1.10(a) looks like a parabola. Find an equation of a parabola close to the graph in Figure 1.10(a). Your calculator may have a program that fits quadratic functions to data, or you may run the MATLAB program:

```
close all;clc;clear
D=[0:1:9];
I=[0.4 0.33 0.27 0.216 0.17 0.14 0.124 0.098 0.082 0.065];
P=polyfit(D,I,2)
X=[0:0.1:9]; Y=polyval(P,X);
plot(D,I,'o','linewidth',2);
hold('on');
plot(X,Y,'linewidth',2)
```

The structure of a program to fit a parabola to data is:

1. Close and clear all previous graphs and variables. [Perhaps unnecessary.]
2. Load the data. [In lists D (depths) and I (light intensity)].
3. Compute the coefficients of a second degree polynomial close to the data and store them in P.
4. Specify X coordinates for the polynomial and compute the corresponding Y coordinates of the polynomial.
5. Plot the original data as points.
6. Plot the computed polynomial.

Compare the fit of the parabola to the data in Figure 1.10(a) with the fit of the graph of $I_d = 0.400 0.82^d$ to the same data illustrated in Figure 1.11.

The parabola fits the data quite well. Why might you prefer $I_d = 0.400 0.82^d$ over the equation of the parabola as an explanation of the data?

Exercise 1.3.4 A light meter suitable for underwater photography was used to measure light intensity in the ocean at Roatan, Honduras. The meter was pointed horizontally. Film speed was set at 400 ASA and time at 1/60 s. The recommended shutter apertures (f stop) at indicated depths are shown in Table Ex. 1.3.4. We show below that the light intensity is proportional to the square of the recommended shutter aperture. Do the data show exponential decay of light?

Notes. The quanta of light required to expose the 400 ASA film is a constant, C . The amount of light that strikes the film in one exposure is $A \Delta T I$, where A is area of shutter opening, ΔT is the time of exposure (set to be 1/60 s) and I is light intensity (quanta/(cm² -sec)). Therefore

$$C = A \Delta T \times I \quad \text{or} \quad I = C \frac{1}{\Delta T} \frac{1}{A} = 60C \frac{1}{A}$$

By definition of f -stop, for a lense of focal length, F , the diameter of the shutter opening is $F/(f\text{-stop})$ mm. Therefore

$$A = \pi \left(\frac{F}{f\text{-stop}} \right)^2$$

The last two equations yield

$$I = 60C \frac{1}{\pi} \frac{1}{F^2} (f\text{-stop})^2 = K(f\text{-stop})^2 \quad \text{where} \quad K = 60C \frac{1}{\pi} \frac{1}{F^2}.$$

Thus light intensity, I is proportional to $(f\text{-stop})^2$.

Table for Exercise 1.3.4 f -stop specifications for 400 ASA film at 1/60 s exposure at various depths below the surface of the ocean near Roatan, Honduras.

Depth m	f -stop
3	16
6	11
9	8
12	5.6
15	4

1.4 Doubling Time and Half-Life.

Populations whose growth can be described by an exponential function (such as $Pop = 0.022 \cdot 1.032^T$) have a characteristic *doubling time*, the time required for the population to double. The graph of the *V. natriegens* data and the graph of $P = 0.022 \cdot 1.032^T$ (Equation 1.5) that we derived from that data is shown in Figure 1.12. **See Also:** http://mathinsight.org/doubling_time_half_life_discrete

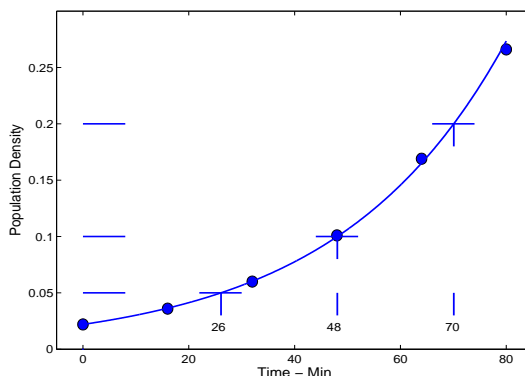

Figure 1.12: Data for *V. natriegens* growth and the graph of $P = 0.022 \cdot 1.032^T$.

Observe that at $T = 26$, $P = 0.05$ and at $T = 48$, $P = 0.1$; thus P doubled from 0.05 to 0.1 in the 22 minutes between $T = 26$ and $T = 48$. Also, at $T = 70$, $P = 0.2$ so the population also doubled from 0.1 to 0.2 between $T = 48$ and $T = 70$, which is also 22 minutes.

The doubling time, T_{Double} , can be computed as follows for exponential growth of the form

$$P = A B^t \quad B > 1$$

Let P_1 be the population at any time T_1 and let T_2 be the time at which the population is twice P_1 . The doubling time, T_{Double} , is by definition $T_2 - T_1$ and

$$P_1 = A B^{T_1} \quad \text{and} \quad P_{T_2} = 2 P_1 = A B^{T_2}$$

Therefore

$$2 A B^{T_1} = A B^{T_2}$$

$$2 = \frac{B^{T_2}}{B^{T_1}}$$

$$2 = B^{T_2 - T_1}$$

$$T_{\text{Double}} = T_2 - T_1 = \frac{\log 2}{\log B} \quad \text{Doubling Time} \tag{1.16}$$

Thus the doubling time for the equation $P = A B^T$ is $\log 2 / \log B$. *The doubling time depends only on B and not on A nor on the base of the logarithm.*

For the equation, $Pop = 0.022 1.032^T$, the doubling time is $\log 2 / \log 1.032 = 22.0056$, as shown in the graph.

Half Life. For the exponential equation $y = A B^T$ with $B < 1$, y does not grow. Instead, y decreases. The half-life, T_{Half} , of y is the time it takes for y to one-half its initial size. The word, ‘half-life’ is also used in the context $y = A B^x$ where x denotes distance instead of time.

Data for light extinction below the surface of a lake from Section 1.3 on page 14 is shown in Figure 1.13 together with the graph of

$$I_d = 0.4 0.82^d$$

Horizontal segments at $Light = 0.4$, $Light = 0.2$, and $Light = 0.1$ cross the curve in Figure 1.13 at $d = 0$, $d = 3.5$ and $d = 7$. The ‘half-life’ of the light is 3.5 layers of water.

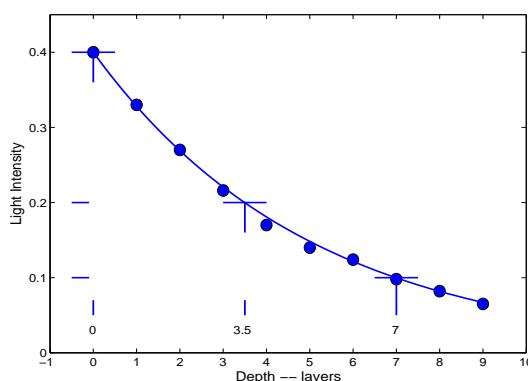

Figure 1.13: Graph of light intensity with depth and the curve $I_d = 0.4 0.82^d$.

It might make more sense to you to call the number 3.5 the ‘half-depth’ of the light, but you will be understood by a wider audience if you call it ‘half-life’.

In Exercise 1.4.9 you are asked to prove that the half-life, T_{Half} , of

$$y = A B^T, \quad \text{where } B < 1 \quad \text{is}$$

$$T_{\text{Half}} = \frac{\log \frac{1}{2}}{\log B} = \frac{-\log 2}{\log B} \quad (1.17)$$

Exercises for Section 1.4 Doubling Time and Half-Life.

Exercise 1.4.1 Determine the doubling times of the following exponential equations.

$$\begin{array}{lll} \text{(a)} & y = 2^t & \text{(b)} & y = 2^{3t} & \text{(c)} & y = 2^{0.1t} \\ \text{(d)} & y = 10^t & \text{(e)} & y = 10^{3t} & \text{(f)} & y = 10^{0.1t} \end{array}$$

Exercise 1.4.2 Show that the doubling time of $y = A B^t$ is $1/(\log_2 B)$.

Exercise 1.4.3 Show that the doubling time of $y = A 2^{kt}$ is $1/k$.

Exercise 1.4.4 Determine the doubling times or half-lives of the following exponential equations.

$$\begin{array}{lll} \text{(a)} & y = 0.5^t & \text{(b)} & y = 2^{3t} & \text{(c)} & y = 0.1^{0.1t} \\ \text{(d)} & y = 100 \cdot 0.8^t & \text{(e)} & y = 4 \cdot 5^{3t} & \text{(f)} & y = 0.0001 \cdot 5^{0.1t} \\ \text{(g)} & y = 10 \cdot 0.8^{2t} & \text{(h)} & y = 0.01^{3t} & \text{(i)} & y = 0.01^{0.1t} \end{array}$$

Exercise 1.4.5 Find a formula for a population that grows exponentially and

- Has an initial population of 50 and a doubling time of 10 years.
- Has an initial population of 1000 and a doubling time of 50 years.
- Has an initial population of 1000 and a doubling time of 100 years.

Exercise 1.4.6 An investment of amount A_0 dollars that accumulates interest at a rate r compounded annually is worth

$$A_t = A_0(1 + r)^t$$

dollars t years after the initial investment.

- Find the value of A_{10} if $A_0 = 1$ and $r = 0.06$.
- For what value of r will $A_8 = 2$ if $A_0 = 1$?
- Investment advisers sometimes speak of the ‘Rule of 72’, which asserts that an investment at R percent interest will double in $72/R$ years. Check the Rule of 72 for $R = 4$, $R = 6$, $R = 8$, $R = 9$ and $R = 12$.

Exercise 1.4.7 Light intensities, I_1 and I_2 , are measured at depths d in meters in two lakes on two different days and found to be approximately

$$I_1 = 2 \cdot 2^{-0.1d} \quad \text{and} \quad I_2 = 4 \cdot 2^{-0.2d}.$$

- a. What is the half-life of I_1 ?
- b. What is the half-life of I_2 ?
- c. Find a depth at which the two light intensities are the same.
- d. Which of the two lakes is the muddiest?

- Exercise 1.4.8**
- a. The mass of a single *V. natriegens* bacterial cell is approximately $2 \cdot 10^{-11}$ grams. If at time 0 there are 10^8 *V. natriegens* cells in your culture, what is the mass of bacteria in your culture at time 0?
 - b. We found the doubling time for *V. natriegen* to be 22 minutes. Assume for simplicity that the doubling time is 30 minutes and that the bacteria continue to divide at the same rate. How many minutes will it take to have a mass of bacteria from Part a. equal one gram?
 - c. The earth weighs $6 \cdot 10^{27}$ grams. How many minutes will it take to have a mass of bacteria equal to the mass of the Earth? How many hours is this? Why aren't we worried about this in the laboratory? Why hasn't this happened already in nature? Explain why it is not a good idea to extrapolate results far beyond the end-point of data gathering.

Exercise 1.4.9 Show that $y = A B^t$ with $B < 1$ has a half-life of

$$T_{\text{Half}} = \frac{\log \frac{1}{2}}{\log B} = \frac{-\log 2}{\log B}.$$

1.5 Quadratic Solution Equations: Mold growth

We examine mold growing on a solution of tea and sugar and find that models of this process lead to quadratic solution equations in contrast to the previous mathematical models which have exponential solution equations. Quadratic solution equations (equations of the form $y = at^2 + bt + c$) occur less frequently than do exponential solution equations in models of biological systems.

Shown in Figure 1.14 are some pictures taken of a mold colony growing on the surface of a mixture of tea and sugar. The pictures were taken at 10:00 each morning for 10 consecutive days. Assume that the area occupied by the mold is a reasonable measure of the size of the mold population. The grid lines are at 2mm intervals.

Explore 1.5.1 From the pictures, measure the areas of the mold for the days 2 and 6 and enter them into the table of Figure 1.15. The grid lines are at 2mm intervals, so that each square is 4mm^2 . Check your additional data with points on the graph. ■

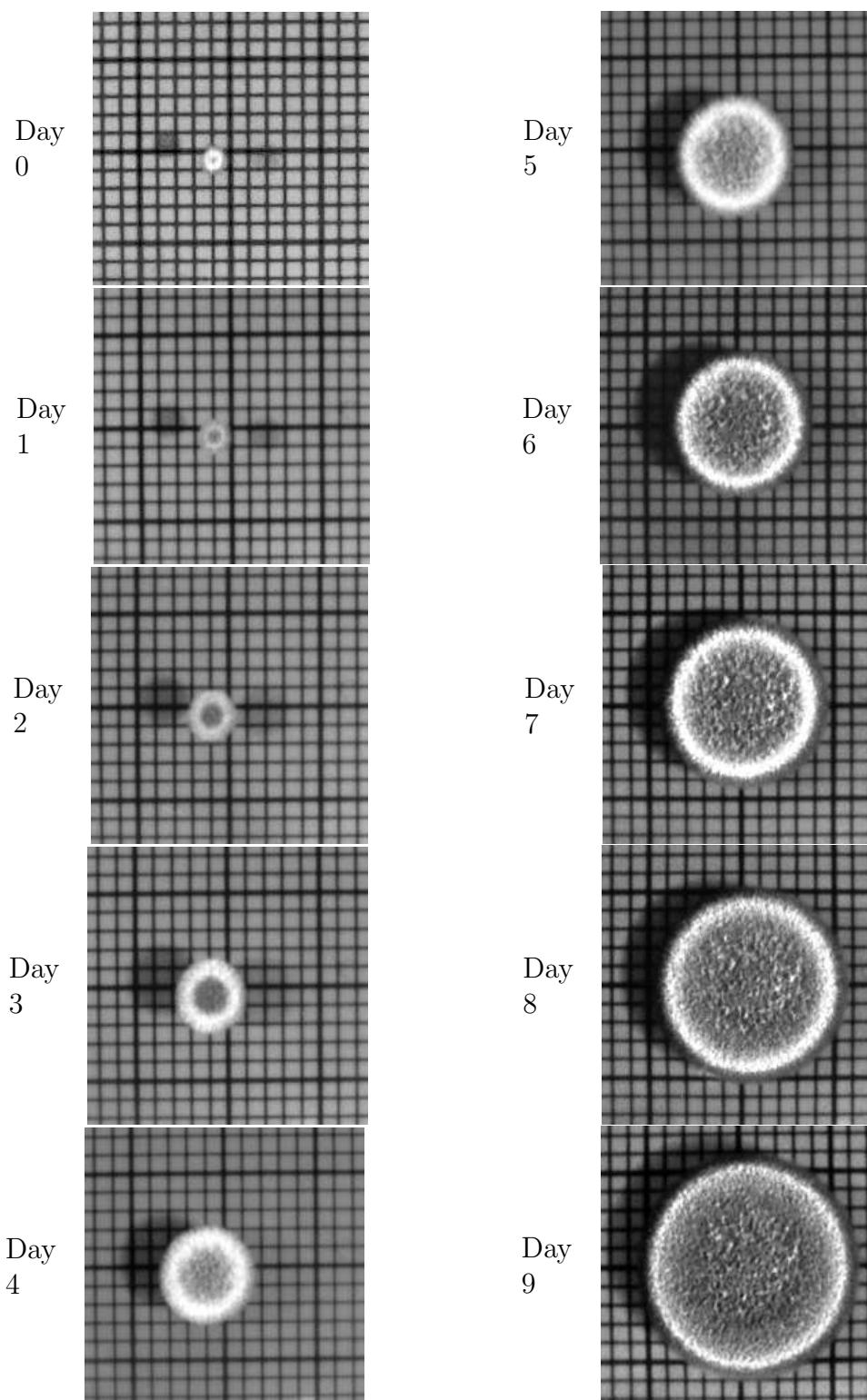

Figure 1.14: Pictures of a mold colony, taken on ten successive days. The grid lines are at 2mm intervals.

Day	Area	Day	Area
0	4	5	126
1	8	6	—
2	—	7	248
3	50	8	326
4	78	9	420

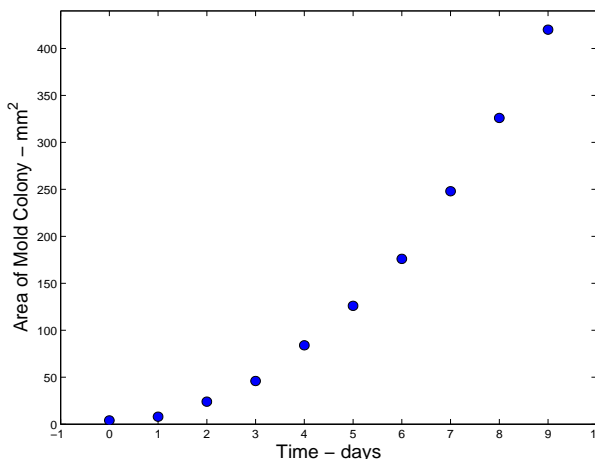

Figure 1.15: Areas of the mold colonies shown in Figure 1.14

Explore 1.5.2 Do this. It is interesting and important to the remaining analysis. Find numbers A and B so that the graph of $y = AB^t$ approximates the mold growth data in Figure 1.14. Either chose two data points and insist that the points satisfy the equation or use a calculator or computer to compute the least squares approximation to the data. Similarly find a parabola $y = at^2 + bt + c$ that approximates the mold data. Draw graphs of the mold data, the exponential function, and the parabola that you found on a single set of axes. ■

Many people would expect the mold growth to be similar to bacterial growth and to have an *exponential* solution equation. We wish to explore the dynamics of mold growth.

Step 1. Mathematical model. Look carefully at the pictures in Figure 1.14. Observe that the features of the interior dark areas, once established, do not change. The growth is restricted to the perimeter of the colony⁷. On this basis we propose the model

Mathematical Model 1.5.1 Mold growth. Each day the increase in area of the colony is proportional to the length of the perimeter of the colony at the beginning of the day (when the photograph was taken).

Step 2. Notation. We will let t denote day of the experiment, A_t the area of the colony and C_t the length of the colony perimeter at the beginning of day t .

Step 3. Dynamic equation. The statement that ‘a variable A is proportional to a variable B ’ means that there is a constant, k , and

$$A = k B$$

Thus, ‘the increase in area of the colony is proportional to the perimeter’ means that there is a constant, k , such that

$$\text{increase in area} = k \text{ perimeter}$$

The increase in the area of the colony on day t is $A_{t+1} - A_t$, the area at the beginning of day $t + 1$ minus the area at the beginning of day t . We therefore write

$$A_{t+1} - A_t = k C_t$$

⁷The pictures show the mold colony from above and we are implicitly taking the area of the colony as a measure of the colony size. There could be some cell division on the underside of the colony that would not be accounted for by the area. Such was not apparent from visual inspection during growth as a clear gelatinous layer developed on the underside of the colony.

We now make the assumption that the mold colony is circular, so that⁸

$$C_t = 2\sqrt{\pi}\sqrt{A_t}$$

Therefore

$$A_{t+1} - A_t = k 2\sqrt{\pi}\sqrt{A_t} \quad (1.18)$$

Step 5. Solve the dynamic equation. The dynamic equation 1.18 is difficult to solve, and may not have a useful formula for its solution⁹. The formula, $A_t = 0$, defines a solution that is not useful. (Exercise 1.5.2).

A similar dynamic equation

$$A_{t+1} - A_{t-1} = K\sqrt{A_t} \quad (1.19)$$

has a solution

$$A_t = \frac{K^2}{16}t^2 \quad (1.20)$$

and we ask you to confirm this solution in Exercise 1.5.5. The solution $A_t = \frac{K^2}{16}t^2$ has $A_0 = 0$, which is not entirely satisfactory. (There was no mold on day 0.)

You are asked in Exercise 1.5.4 to estimate $k 2\sqrt{\pi}$ of Equation 1.18 and to iteratively compute approximations to A_0, \dots, A_9 .

The difficulties at this stage lead us to reconsider the original problem.

Step 4. Reformulate the mathematical model. We have assumed the mold colony to be a circle expanding at its edges. We suggest that the radius is increasing at a constant rate, and write the following model.

Step 1. Mold growth, reformulated. Each day the radius of the colony increases by a constant amount.

Step 2. Notation, again. Let ρ_t be the radius¹⁰ of the colony at the beginning of day t , and let Δ (Greek letter delta) denote constant daily increase in radius.

Step 3. Dynamic equation, again. The increase in radius on day t is $\rho_{t+1} - \rho_t$, the radius at the beginning of day $t + 1$ minus the radius at the beginning of day t , and we write

$$\rho_{t+1} - \rho_t = \Delta \quad (1.21)$$

An important procedure in developing equations is to write a single thing two different ways, as we have just done for the increase in radius. Indeed, most equations do write a single thing two different ways.

You should check that the dimensions of the quantities on both sides of your equation are identical. This may assist in identifying dimensions of parameters in your equation.

⁸For a circle of radius r ,

$$\text{Area: } A = \pi r^2, \quad r = \sqrt{A/\pi}, \quad \text{Circumference: } C = 2\pi r = 2\pi\sqrt{A/\pi} = 2\sqrt{\pi}\sqrt{A}$$

⁹We spare you the details, but it can be shown that there is neither a quadratic nor exponential solution to Equation 1.18

¹⁰We use the Greek letter ρ (rho) for the radius. We have already used R and r in another context.)

Step 4. Solution equation, again. Convert $\rho_{t+1} - \rho_t = \Delta$ to $\rho_{t+1} = \rho_t + \Delta$ and write

$$\begin{aligned}\rho_1 &= \rho_0 + \Delta, \\ \rho_2 &= \rho_1 + \Delta \\ &= (\rho_0 + \Delta) + \Delta = \rho_0 + 2\Delta\end{aligned}$$

and correctly guess that

$$\rho_t = \rho_0 + t \Delta \tag{1.22}$$

Evaluate ρ_0 and Δ . From $A_t = \pi\rho_t^2$, $\rho_t = \sqrt{A_t/\pi}$, and

$$\begin{aligned}\rho_0 &= \sqrt{A_0/\pi} = \sqrt{4/\pi} = 1.13 \\ \rho_9 &= \sqrt{A_9/\pi} = \sqrt{420/\pi} = 11.56\end{aligned}$$

There are 9 intervening days between measurements ρ_0 and ρ_9 so the average daily increase in radius is

$$\Delta = \frac{11.56 - 1.13}{9} = 1.16$$

We therefore write ($\rho_0 = 1.13$, $\Delta = 1.16$)

$$\rho_t = 1.13 + t \cdot 1.16$$

Now from $A_t = \pi\rho_t^2$ we write

$$A_t = \pi(1.13 + 1.16t)^2 \tag{1.23}$$

Step 6. Compare predictions from the model with observed data. A graph of $A_t = \pi(1.13 + 1.16t)^2$ and the original mold areas is shown in Figure 1.16 where we can see a reasonable fit, but there is a particularly close match at the two end points. It may be observed that only those two data points enter into calculations of the parameters 1.13 and 1.16 of the solution, which explains why the curve is close to them.

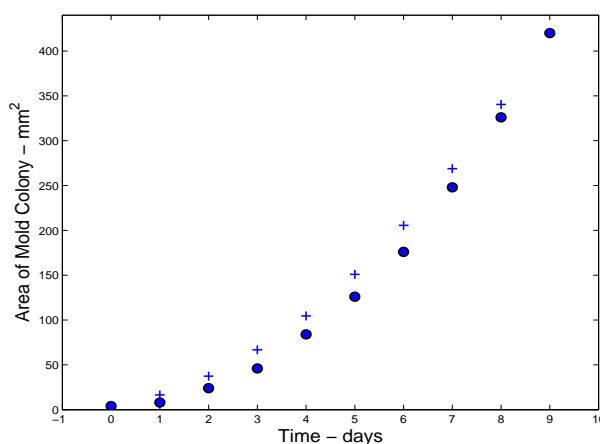

Figure 1.16: Comparison of the solution equation 1.23 with the actual mold growth data.

Exercise 1.5.1 You will have found in Explore 1.5.2 that the data is approximated pretty well by both an exponential function and a quadratic function. Why might you prefer a quadratic function?

Exercise 1.5.2 Show that $A_t = 0$ for all t is a solution to Equation 1.18,

$$A_{t+1} - A_t = 2\pi k\sqrt{A_t}$$

This means that for every t , if $A_t = 0$ and A_{t+1} is computed from the equation, then $A_{t+1} = 0$ (and, yes, this is simple).

Exercise 1.5.3 Use data at days 2 and 8, (2,24) and (8,326), to evaluate Δ and ρ_0 in Equation 1.22

$$\rho_t = \rho_0 + t \Delta.$$

See Step 4, Solution Equation, Again.

Use the new values of ρ_0 and Δ in $\rho_t = \rho_0 + t \Delta$ to compute estimates of $\rho_0, \rho_1, \dots, \rho_9$ and A_0, A_1, \dots, A_9 . Plot the new estimates of A_t and the observed values of A_t and compare your graph with Figure 1.16.

Exercise 1.5.4 a. Compute $A_{t+1} - A_t$ and $\sqrt{A_t}$ for the mold data in Figure 1.15 and plot $A_{t+1} - A_t$ vs $\sqrt{A_t}$. You should find that the line $y = 5x$ lies close to the data. This suggests that 5 is the value of $k 2\sqrt{\pi}$ in Equation 1.18, $A_{t+1} - A_t = k 2\sqrt{\pi}\sqrt{A_t}$.

b. Use

$$A_0 = 4, \quad A_{t+1} - A_t = 5\sqrt{A_t}$$

to compute estimates of A_1, \dots, A_9 . Compare the estimates with the observed data.

c. Find a value of K so that the estimates computed from

$$A_0 = 4, \quad A_{t+1} - A_t = K\sqrt{A_t}$$

more closely approximates the observed data than do the previous approximations.

Exercise 1.5.5 Examine the following model of mold growth:

Model of mold growth, III. The increase in area of the mold colony during any time interval is proportional to the length of the circumference of the colony at the midpoint of the time interval.

A schematic of a two-day time interval is

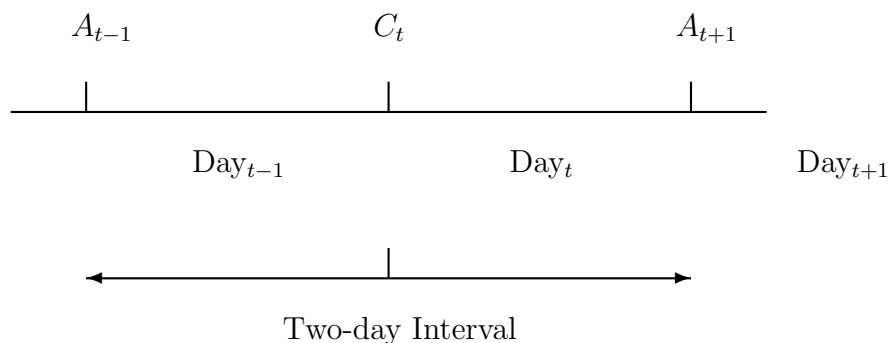

a. Explain the derivation of the dynamic equation

$$A_{t+1} - A_{t-1} = k C_t$$

from Model of mold growth, III.

With $C_t = 2\sqrt{\pi}\sqrt{A_t} = K\sqrt{A_t}$, the dynamic equation becomes

$$A_{t+1} - A_{t-1} = K\sqrt{A_t}$$

b. Show by substitution that

$$A_t = \frac{K^2}{16}t^2 \quad \text{is a solution to} \quad A_{t+1} - A_{t-1} = K\sqrt{A_t}$$

To do so, you will substitute $A_{t+1} = \frac{K^2}{16}(t+1)^2$, $A_{t-1} = \frac{K^2}{16}(t-1)^2$, and $A_t = \frac{K^2}{16}t^2$, and show that the left and right sides of the equation simplify to $\frac{K^2}{4}t$.

c. When you find a value for K , you will have a quadratic solution for mold growth.

In the Figure 1.17 are values of $A_{t+1} - A_{t-1}$ and $\sqrt{A_t}$ and a plot of $A_{t+1} - A_{t-1}$ vs $\sqrt{A_t}$, with one data point omitted. Compute the missing data and identify the corresponding point on the graph.

Time t Days	Area A_t mm ²	$\sqrt{A_t}$ mm	Change $A_{t+1} - A_{t-1}$ mm ²
0	4		
1	8	2.83	20
2	24	4.89	38
3	46	6.78	60
4	84	9.17	80
5	126		
6	176	12.00	122
7	248	13.27	150
8	326	18.06	172
9	420	20.49	

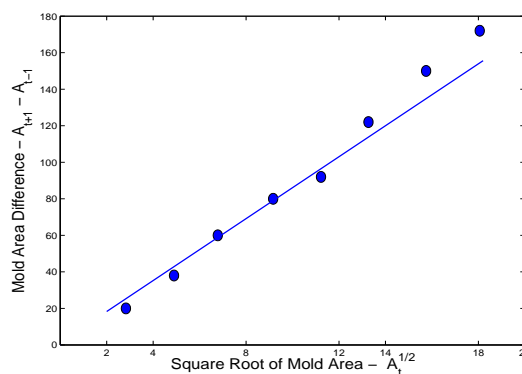

Figure 1.17: Data for Exercise 1.5.5, to estimate K in $A_{t+1} - A_{t-1} = K\sqrt{A_t}$.

d. Also shown on the graph of $A_{t+1} - A_{t-1}$ vs $\sqrt{A_t}$ is the graph of $y = 9.15x$ which is the line of the form $y = mx$ that is closest to the data. Let $K = 9.15$ in $A_t = \frac{K^2}{16}t^2$ and compute A_0, A_1, \dots, A_9 . Compare the computed values with the observed values of mold areas.

Exercise 1.5.6 Suppose a, b , and c are numbers and

$$P_t = at^2 + bt + c$$

where t is any number. Show that

$$Q_t = P_{t+1} - P_t$$

is linearly related to t (that is, $Q_t = \alpha t + \beta$ for some α and β), and that

$$R_t = Q_{t+1} - Q_t$$

is a constant.

1.6 Constructing a Mathematical Model of Penicillin Clearance.

In this section you will build a model of depletion of penicillin from plasma in a patient who has received a bolus injection of penicillin into the plasma.

When penicillin was first discovered, its usefulness was limited by the efficiency with which the kidney eliminates penicillin from the blood plasma passing through it. "Penicillin is actively excreted, and about 80% of a penicillin dose is cleared from the body within three to four hours of administration. Indeed, during the early penicillin era, the drug was so scarce and so highly valued that it became common to collect the urine from patients being treated, so that the penicillin in the urine could be isolated and reused."¹¹ The modifications that have been made to penicillin (leading to ampicillin, moxycillin, mezlocillin, etc.) have enhanced its ability to cross membranes and reach targeted infections and reduced the rate at which the kidney clears the plasma of penicillin. Even with these improvements in penicillin, the kidneys remove 20 percent of the penicillin in the plasma passing through them. Furthermore, all of the blood plasma of a human passes through the kidneys in about 5 minutes. We therefore formulate

Mathematical Model 1.6.1 Renal clearance of penicillin. In each five minute interval following penicillin injection, the kidneys remove a fixed fraction of the penicillin that was in the plasma at the beginning of the five minute interval.

We believe the fraction to be about 0.2 so that 5 minutes after injection of penicillin into a vein, only 80% of the penicillin remains. This seems surprising and should cause you to question our assertion about renal clearance of penicillin¹². **See Also:**
http://mathinsight.org/penicillin_clearance_model

An amount of drug placed instantaneously (that is, over a short period of time) in a body compartment (plasma, stomach, muscle, etc.) is referred to as a *bolus injection*. An alternative procedure is *continuous infusion* as occurs with an intravenous application of a drug. Geologists refer to a meteor entering the atmosphere as a bolide. Data for penicillin concentration following a 2 g bolus injection are shown in Figure 1.18.

Explore 1.6.1 We think you will be able to develop this model without reading our development, and will find it much more interesting than reading a solution. You have a mathematical model and relevant data. You need to

Step 2. Introduce appropriate notation.

Step 3. Write a dynamic equation describing the change in penicillin concentration. You will need a crucial negative sign here, because penicillin is removed, and the change in penicillin concentration is negative. Evaluate a parameter of the dynamic equation.

¹¹<http://en.wikipedia.org/wiki/Penicillin>, which cites Silverthorn, D.U., *Human Physiology: An Integrated Approach* (3rd Ed.) Upper Saddle River, NJ, Pearson Education

¹²That all of the plasma passes through the kidney in 5 minutes is taken from Rodney A. Rhoades and George A. Tanner, *Medical Physiology*, Little, Brown and Company, Boston, 1995. "In resting, healthy, young adult men, renal blood flow averages about 1.2 L/min", page 426, and "The blood volume is normally 5-6 L in men and 4.5-5.5 L in women.", page 210. "Hematocrit values of the blood of health adults are $47 \pm 5\%$ for men and $42 \pm 5\%$ for women", page 210 suggests that the amount of plasma in a male is about $6 \text{ L} \times 0.53 = 3.18 \text{ L}$. J. A. Webber and W. J. Wheeler, Antimicrobial and pharmacokinetic properties, in *Chemistry and Biology of β -Lactin Antibiotics*, Vol. 1, Robert B. Morin and Marvin Gorman, Eds. Academic Press, New York, 1982, page 408 report plasma renal clearances of penicillin ranging from 79 to 273 ml/min. Plasma (blood minus blood cells) is approximately 53% of the blood so plasma flow through the kidney is about $6 \text{ liters} \times 0.53/5 \text{ min} = 0.636 \text{ l/min}$. Clearance of 20% of the plasma yields plasma penicillin clearance of $0.636 \times 0.2 = 0.127 \text{ l/min} = 127 \text{ ml/min}$ which is between 79 and 273 ml/min.

Time min	Penicillin Concentration $\mu\text{g/ml}$
0	200
5	152
10	118
15	93
20	74

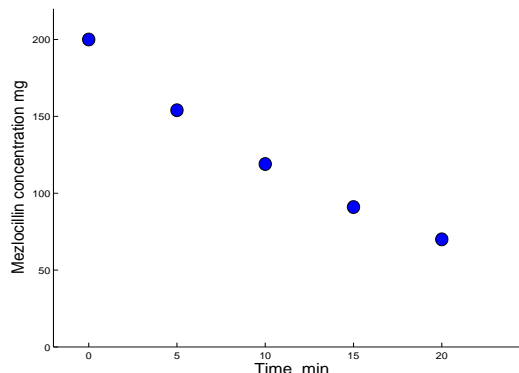

Figure 1.18: Data for serum penicillin concentrations at 5 minute intervals for the 20 minutes following a ‘bolus’ injection of 2 g into the serum of “five healthy young volunteers (read ‘medical students’)” taken from T. Bergans, Penicillins, in *Antibiotics and Chemotherapy*, Vol 25, H. Schönfeld, Ed., S. Karger, Basel, New York, 1978. We are interpreting serum in this case to be plasma.

Step 4. Review the mathematical model (it will be excellent and this step can be skipped).

Step 5. Write a solution equation to the dynamic equation.

Step 6. Compare values computed with the solution equation with the observed data (you will find a very good fit).

You will find that from this data, 23 percent of the mezlocillin leaves the serum every five minutes.

■

Exercises for Section 1.6, Constructing a Mathematical Model of Penicillin Clearance.

Exercise 1.6.1 A one-liter flask contains one liter of distilled water and 2 g of salt. Repeatedly, 50 ml of solution are removed from the flask and discarded after which 50 ml of distilled water are added to the flask. Introduce notation and write a dynamic equation that will describe the change of salt in the beaker each cycle of removal and replacement. How much salt is in the beaker after 20 cycles of removal?

Exercise 1.6.2 A 500 milligram penicillin pill is swallowed and immediately enters the intestine. Every five minute period after ingestion of the pill

- 10% of the penicillin in the intestine at the beginning of the period is absorbed into the plasma.
- 15% of the penicillin in the plasma at the beginning of the period is removed by the kidney.

Let I_t be the amount of penicillin in the intestine and S_t be the amount of penicillin in the plasma at the end of the t th five minute period after ingestion of the pill. Complete the following

equations, including + and - signs.

Initial conditions

$$I_0 = \underline{\hspace{2cm}}$$

$$S_0 = \underline{\hspace{2cm}}$$

Penicillin change
per time period

Penicillin
removed

Penicillin
added

$$I_{t+1} - I_t = \underline{\hspace{2cm}} \quad \underline{\hspace{2cm}}$$

$$S_{t+1} - S_t = \underline{\hspace{2cm}} \quad \underline{\hspace{2cm}}$$

Exercise 1.6.3 Along with the data for 2 gm bolus injection of mezlocillin, T. Bergan reported serum mezlocillin concentrations following 1 g bolus injection in healthy volunteers and also data following 5 g injection in healthy volunteers. Data for the first twenty minutes of each experiment are shown in Table Ex. 1.6.3.

- Analyze the data for 1 g injection as prescribed below.
- Analyze the data for 5 g injection as prescribed below.

Analysis. Compute $P_{t+1} - P_t$ for $t = 0, 1, 2, 3$ and find a straight line passing through $(0,0)$, $(y = mx)$, close to the graph of $P_{t+1} - P_t$ vs P_t . Compute a solution to $P_{t+1} - P_t = mP_t$, and use your solution equation to compute estimated values of P_t . Prepare a table and graph to compare your computed solution with the observed data.

Table for Exercise 1.6.3 Plasma mezlocillin concentrations at five minute intervals following injection of either 1 g of mezlocillin or 5 g of mezlocillin into healthy volunteers.

1 g injection			5 g injection		
Time min	Time Index	Mezlocillin concentration $\mu\text{g/ml}$	Time min	Time Index	Mezlocillin concentration $\mu\text{g/ml}$
0	0	71	0	0	490
5	1	56	5	1	390
10	2	45	10	2	295
15	3	33	15	3	232
20	4	25	20	4	182

Exercise 1.6.4 Two liters of fresh water (distilled H_2O) is contained in a plastic bag that is floating in the ocean. A small area of a side of the plastic bag is a semipermeable membrane (permeable to water but not to salt). Osmosis will drive the water out of the plastic bag and into the ocean

Write a mathematical model of the transfer of water from the plastic bag to the ocean. Introduce notation and write an initial condition and a difference equation with that will describe the amount of water in the small container.

Exercise 1.6.5 There is a standard osmosis experiment in biology laboratory as follows.

Material: A thistle tube, a 1 liter flask, some ‘salt water’, and some pure water, a membrane that is impermeable to the salt and is permeable to the water.

The bulb of the thistle tube is filled with salt water, the membrane is placed across the open part of the bulb, and the bulb is inverted in a flask of pure water so that the top of the pure water is at the juncture of the bulb with the stem.

Because of osmotic pressure the pure water will cross the membrane pushing water up the stem of the thistle tube until the increase in pressure inside the bulb due to the water in the stem matches the osmotic pressure across the membrane.

Our problem is to describe the height of the water in the stem as a function of time. The following mathematical model would be appropriate.

Mathematical Model. The amount of water crossing the membrane during any minute is proportional to the osmotic pressure across the membrane minus the pressure due to the water in the stem at the beginning of the minute.

Assume that the volume of the bulb is much larger than the volume of the stem so that the concentration of ‘salt’ in the thistle tube may be assumed to be constant, thus making the osmotic pressure a constant, P_0 (This is fortunate!). Assume that the radius of the thistle tube stem is r cm. Then an amount, V cm³, of additional water inside the thistle tube will cause the water to rise $V/(\pi r^2)$ cm. Assume the density of the salt water to be δ gm/cm.

Introduce notation and write a difference equation with initial condition that will describe the height of the water in the stem as a function of time.

1.7 Movement toward equilibrium.

Now we consider a new mathematical model that is used to describe the response of systems to constant infusion of material or energy. Examples include

- A pristine lake has a constant flow of fresh water into it and an equal flow of water out of the lake. A factory is built next to the lake and each day releases a fixed amount of chemical waste into the lake. The chemical waste will mix through out the lake and some will leave the lake in the water flowing out. The amount of chemical waste in the lake will increase until the amount of chemical leaving the lake each day is the same as the amount released by the factory each day.
- The nitrogen in the muscle of a scuba diver is initially at 0.8 atm, the partial pressure of N_2 in atmospheric air. She descends to 20 meters and breathes air with N_2 partial pressure 2.4 atm. Almost immediately her blood N_2 partial pressure is also 2.4 atm. Her muscle absorbs N_2 more slowly; each minute the amount of N_2 that flows into her muscle is proportional to the difference between the partial pressures of N_2 in her blood (2.4 atm) and in her muscle. Gradually her muscle N_2 partial pressure moves toward 2.4 atm.
- A hen leaves a nest and exposes her eggs to air at temperatures that are lower than the 37 °C of the eggs when she left. The temperature of the eggs will decrease toward the temperature of the air.

Example 1.7.1 *Chemical pollution in a lake.* A pristine lake of area 2 km² and average depth of 10 meters has a river flowing through it at a rate of 10,000 m³ per day. A factory is built beside the river and releases 100 kg of chemical waste into the lake each day. What will be the amounts of chemical waste in the lake on succeeding days? **See Also:**

http://mathinsight.org/chemical_pollution_lake_model

We propose the following mathematical model.

Step 1. Mathematical Model. The daily change in chemical waste in the lake is difference between the amount released each day by the factory and the amount that flows out of the lake down the exit river. The amount of chemical waste that leaves the lake each day is equal to the amount of water that leaves the lake that day times the concentration of chemical waste in that water. Assume that upon release from the factory, the chemical quickly mixes throughout the lake so that the chemical concentration in the lake is uniform.

Step 2. Notation. Let t be time measured in days after the factory opens and W_t be the chemical waste in kg and C_t the concentration of chemical waste in kg/m³ in the lake on day t . Let V be the volume of the lake and F the flow of water through the lake each day.

Step 3. Equations. The lake volume its area times its depth; according to the given data,

$$V = 2\text{km}^2 \cdot 10\text{m} = 2 \cdot 10^7 \text{m}^3.$$

$$F = 10^4 \frac{\text{m}^3}{\text{day}}$$

The concentration of chemical in the lake is $C_t = \frac{W_t}{V} = \frac{W_t}{2 \times 10^7} \frac{\text{kg}}{\text{m}^3}$

The change in the amount of chemical on day t is $W_{t+1} - W_t$ and

$$\text{Change per Day} = \text{Amount Added per Day} - \text{Amount Removed per Day}$$

$$W_{t+1} - W_t = 100 - F C_t$$

$$W_{t+1} - W_t = 100 - 10^4 \frac{W_t}{2 \cdot 10^7}$$

$$W_{t+1} - W_t = 100 - 5 \cdot 10^{-4} W_t$$

The units in the equation are

$$W_{t+1} - W_t = 100 - 10^4 \frac{W_t}{2 \cdot 10^7}$$

$$\text{kg} - \text{kg} = \text{kg} - \text{m}^3 \frac{\text{kg}}{\text{m}^3}$$

and they are consistent.

On day 0, the chemical content of the lake is 0. Thus we have

$$W_0 = 0$$

$$W_{t+1} - W_t = 100 - 5 \cdot 10^{-4} W_t$$

and we rewrite it as

$$W_0 = 0$$

$$W_{t+1} = 100 + 0.9995 W_t$$

Step 5. Solve the dynamic equation. We can compute the amounts of chemical waste in the lake on the first few days¹³ and find 0, 100, 199.95, 299.85, 399.70 for the first five entries. We

¹³On your calculator: 0 ENTER × 0.9995 + 100 ENTER ENTER ENTER ENTER

could iterate 365 times to find out what the chemical level will be at the end of one year (but would likely loose count).

Equilibrium State. The environmentalists want to know the ‘eventual state’ of the chemical waste in the lake. They would predict that the chemical in the lake will increase until there is no perceptual change on successive days. The *equilibrium state* is a number E such that if $W_t = E$, W_{t+1} is also E . From $W_{t+1} = 100 + 0.9995W_t$ we write

$$E = 100 + 0.9995 E, \quad E = \frac{100}{1 - 0.9995} = 200,000.$$

When the chemical in the lake reaches 200,000 kg, the amount that flows out of the lake each day will equal the amount introduced from the factory each day.

The equilibrium E is also useful mathematically. Subtract the equations

$$\begin{aligned} W_{t+1} &= 100 + 0.9995W_t \\ E &= 100 + 0.9995E \end{aligned}$$

$$W_{t+1} - E = 0.9995(W_t - E)$$

With $D_t = W_t - E$, this equation is

$$D_{t+1} = 0.9995D_t \quad \text{which has the solution} \quad D_t = D_0 0.9995^t.$$

Then

$$W_t - E = (W_0 - E) 0.9995^t, \quad W_t = 200000 - 200000 0.9995^t$$

The graph of W_t is shown in Figure 1.19, and W_t is asymptotic to 200,000 kg.

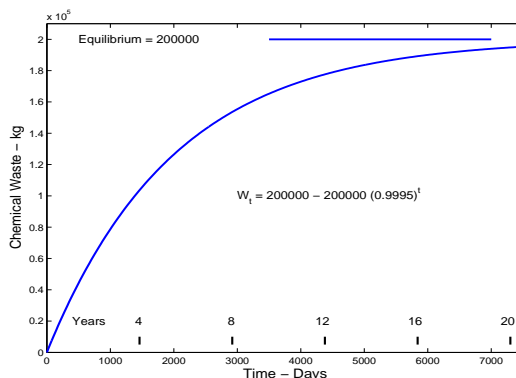

Figure 1.19: The amount of waste chemical in a lake.

You can read the chemical level of the lake at the end of one year from the graph or compute

$$W_{365} = 200000 - 200000 0.9995^{365} \doteq 33,000kg$$

33,000 of the 36,500 kg of chemical released into the lake during the first year are still in the lake at the end of the year. Observe that even after 20 years the lake is not quite to equilibrium.

We can find out how long it takes for the lake to reach 98 percent of the equilibrium value by asking for what t is $W_t = 0.98 \cdot 200000$?. Thus,

$$\begin{aligned} W_t = 0.98 \cdot 200000 &= 200000 - 200000 \cdot 0.9995^t \\ 0.98 &= 1 - 0.9995^t \\ 0.9995^t &= 0.02 \\ \log 0.9995^t &= \log 0.02 \\ t \log 0.9995 &= \log 0.02 \\ t &= \frac{\log 0.02}{\log 0.9995} = 7822 \text{ days} = 21.4 \text{ years} \end{aligned}$$

Step 6. Compare the solution with data. Unfortunately we do not have data for this model. The volume and stream flow were selected to approximate Lake Erie, but the lake is much more complex than our simple model. However, a simulation of the process is simple:

Example 1.7.2 Simulation of chemical discharge into a lake. Begin with two one-liter beakers, a supply of distilled water and salt and a meter to measure conductivity in water. Place one liter of distilled water and 0.5 g of salt in beaker F (factory). Place one liter of distilled water in beaker L (lake). Repeatedly do

- a. Measure and record the conductivity of the water beaker L.
- b. Remove 100 ml of solution from beaker L and discard.
- c. Transfer 100 ml of salt water from beaker F to beaker L.

The conductivity of the salt water in beaker F should be about 1000 microsiemens (μS). The conductivity of the water in beaker L should be initially 0 and increase as the concentration of salt in L increases. Data and a graph of the data are shown in Figure 1.20 and appears similar to the graph in Figure 1.19. In Exercise 1.7.4 you are asked to write and solve a mathematical model of this simulation and compare the solution with the data. ■

Cycle Number	Conductivity μS
0	0
1	112
2	207
3	289
4	358
5	426
6	482
7	526
8	581

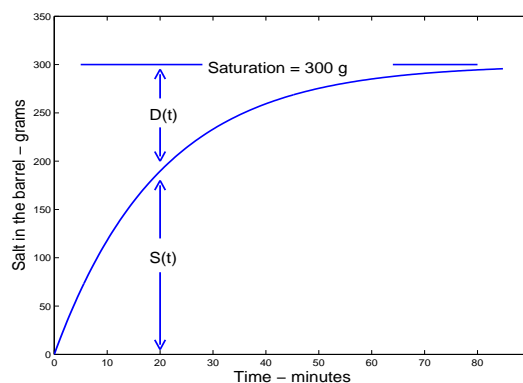

Figure 1.20: Data for Example 1.7.2, simulation of infusion of chemical waste product in a lake.

Exercises for Section 1.7 Movement toward equilibrium.**Exercise 1.7.1** For each of the following systems,

1. Compute $W_0, W_1, W_2, W_3,$ and W_4 .
2. Find the equilibrium value of W_t for the systems.
3. Write a solution equation for the system.
4. Compute W_{100} .
5. Compute the half-life, $T_{1/2} = -\log 2 / \log B$ of the system.

$$\begin{aligned} \text{a. } W_0 &= 0 \\ W_{t+1} &= 1 + 0.2W_t \end{aligned}$$

$$\begin{aligned} \text{b. } W_0 &= 0 \\ W_{t+1} &= 10 + 0.2W_t \end{aligned}$$

$$\begin{aligned} \text{c. } W_0 &= 0 \\ W_{t+1} &= 100 + 0.2W_t \end{aligned}$$

$$\begin{aligned} \text{d. } W_0 &= 0 \\ W_{t+1} &= 10 + 0.1W_t \end{aligned}$$

$$\begin{aligned} \text{e. } W_0 &= 0 \\ W_{t+1} &= 10 + 0.05W_t \end{aligned}$$

$$\begin{aligned} \text{f. } W_0 &= 0 \\ W_{t+1} &= 10 + 0.01W_t \end{aligned}$$

Exercise 1.7.2 For each of the following systems,

1. Compute $W_0, W_1, W_2, W_3,$ and W_4 .
2. Find the equilibrium value of W_t for the systems.
3. Write a solution equation for the system.
4. Compute W_{100} .

$$\begin{aligned} \text{a. } W_0 &= 0 \\ W_{t+1} &= 1 - 0.2W_t \end{aligned}$$

$$\begin{aligned} \text{b. } W_0 &= 0 \\ W_{t+1} &= 10 - 0.2W_t \end{aligned}$$

$$\begin{aligned} \text{c. } W_0 &= 0 \\ W_{t+1} &= 100 - 0.2W_t \end{aligned}$$

$$\begin{aligned} \text{d. } W_0 &= 0 \\ W_{t+1} &= 10 - 0.1W_t \end{aligned}$$

$$\begin{aligned} \text{e. } W_0 &= 0 \\ W_{t+1} &= 10 - 0.05W_t \end{aligned}$$

$$\begin{aligned} \text{f. } W_0 &= 0 \\ W_{t+1} &= 10 - 0.01W_t \end{aligned}$$

Exercise 1.7.3 For each of the following systems,

- a. Compute $W_0, W_1, W_2, W_3,$ and W_4 .
- b. Describe the future terms, W_5, W_6, W_7, \dots .

$$\begin{array}{ll}
 \text{a. } W_0 = 0 & \text{b. } W_0 = \frac{1}{2} \\
 W_{t+1} = 1 - W_t & W_{t+1} = 1 - W_t \\
 \\
 \text{c. } W_0 = 0 & \text{d. } W_0 = 0 \\
 W_{t+1} = 1 + W_t & W_{t+1} = 2 + W_t \\
 \\
 \text{e. } W_0 = 0 & \text{f. } W_0 = -1 \\
 W_{t+1} = 1 + 2W_t & W_{t+1} = 1 + 2W_t
 \end{array}$$

Exercise 1.7.4 Write equations and solve them to describe the amount of salt in the beakers at the beginning of each cycle for the simulation of chemical discharge into a lake of Example 1.7.2.

Exercise 1.7.5 For our model, 1.7.1, of lake pollution, we assume “that upon release from the factory, the chemical quickly mixes throughout the lake so that the chemical concentration in the lake is uniform.” The time scale for ‘quickly’ is relative to the other parts of the model; in this case to the daily flow into and out of the lake. Suppose it takes 10 days for 100 kg of chemical released from the factory to mix uniformly throughout the lake. Write a mathematical model for this case. There are several reasonable models; your task to write one of them.

Exercise 1.7.6 An intravenous infusion of penicillin is initiated into the vascular pool of a patient at the rate of 10 mg penicillin every five minutes. The patients kidneys remove 20 percent of the penicillin in the vascular pool every five minutes.

- Write a mathematical model of the change during each five minute period of penicillin in the patient.
- Write a difference equation that describes the amount of penicillin in the patient during the five minute intervals.
- What is the initial value of penicillin in the patient?
- What will be the equilibrium amount of penicillin in the patient? (This is important to the nurse and the doctor!)
- Write a solution to the difference equation.
- At what time will the penicillin amount in the patient reach 90 percent of the equilibrium value? (The nurse and doctor also care about this. Why?)
- Suppose the patients kidneys are weak and only remove 10 percent of the penicillin in the vascular pool every 5 minutes. What is the equilibrium amount of penicillin in the patient?

Exercise 1.7.7 The nitrogen partial pressure in a muscle of a scuba diver is initially 0.8 atm. She descends to 30 meters and immediately the N_2 partial pressure in her blood is 2.4 atm, and remains at 2.4 atm while she remains at 30 meters. Each minute the N_2 partial pressure in her muscle increases by an amount that is proportional to the difference in 2.4 and the partial pressure of nitrogen in her muscle at the beginning of that minute.

- Write a dynamic equation with initial condition to describe the N_2 partial pressure in her muscle.

- b. Your dynamic equation should have a proportionality constant. Assume that constant to be 0.067. Write a solution to your dynamic equation.
- c. At what time will the N_2 partial pressure be 1.6?
- d. What is the half-life of N_2 partial pressure in the muscle, with the value of $K = 0.067$?

1.8 Solution to the dynamic equation $P_{t+1} - P_t = r P_t + b$.

The general form of the dynamic equation of the previous section is,

$$P_{t+1} - P_t = r P_t + b, \quad t = 0, 1, \dots, \quad P_0 \text{ a known value.} \quad (1.24)$$

The constant b represents influence from outside the system, such as flow or immigration into ($b > 0$) or flow or emigration out of ($b < 0$) the system.

Suppose $r \neq 0$ and $b \neq 0$. We convert

$$P_{t+1} - P_t = r P_t + b$$

to iteration form

$$P_{t+1} = R P_t + b, \quad \text{where} \quad R = r + 1. \quad (1.25)$$

Next we look for an **equilibrium value** E satisfying

$$E = R E + b. \quad (1.26)$$

(Think, if $P_t = E$ then $P_{t+1} = E$.) We can solve for E

$$E = \frac{b}{1 - R} = -\frac{b}{r} \quad (1.27)$$

Now subtract Equation 1.26 from Equation 1.25.

$$\begin{aligned} P_{t+1} &= R P_t + b \\ E &= R E + b \end{aligned}$$

$$P_{t+1} - E = R(P_t - E). \quad (1.28)$$

Let $D_t = P_t - E$ and write

$$D_{t+1} = R D_t.$$

This is iteration Equation 1.7 with D_T instead of P_t and the solution is

$$D_t = R^t D_0.$$

Remembering that $D_t = P_t - E$ and $E = b/(1 - R) = -b/r$ and $R = 1 + r$ we write

$$P_t - E = R^t (P_0 - E), \quad P_t = -\frac{b}{r} + (P_0 + \frac{b}{r})(1 + r)^t. \quad (1.29)$$

You are asked to show in Exercise 1.8.2 that the solution to

$$P_{t+1} - P_t = b \quad \text{is} \quad P_t = P_0 + t b \quad (1.30)$$

Exercises for Section 1.8, Solution to the dynamic equation, $P_{t+1} - P_t = rP_t + b$.

Exercise 1.8.1 Write a solution equation for the following initial conditions and difference equations or iteration equations. In each case, compute B_{100} .

- a. $B_0 = 100$ $B_{t+1} - B_t = 0.2 B_t + 5$
- b. $B_0 = 138$ $B_{t+1} - B_t = 0.05 B_t + 10$
- c. $B_0 = 138$ $B_{t+1} - B_t = 0.5 B_t - 10$
- d. $B_0 = 100$ $B_{t+1} - B_t = 10$
- e. $B_0 = 100$ $B_{t+1} = 1.2 B_t - 5$
- f. $B_0 = 100$ $B_{t+1} - B_t = -0.1 B_t + 10$
- g. $B_0 = 100$ $B_{t+1} = 0.9 B_t - 10$
- g. $B_0 = 100$ $B_{t+1} = -0.8 B_t + 20$

Exercise 1.8.2 Equation 1.30

$$P_{t+1} - P_t = b$$

represents a large number of equations

$$\begin{aligned} P_1 - P_0 &= b \\ P_2 - P_1 &= b \\ P_3 - P_2 &= b \\ &\vdots \\ P_{n-1} - P_{n-2} &= b \\ P_n - P_{n-1} &= b \end{aligned}$$

Add these equations to obtain

$$P_n = P_0 + n b$$

Substitute t for n to obtain

$$P_t = P_0 + t b$$

Exercise 1.8.3 Suppose a quail population would grow at 20% per year without hunting pressure, and 1000 birds per year are harvested. Describe the progress of the population over 5 years if initially there are

- a. 5000 birds, b. 6000 birds, and c. 4000 birds.

1.9 Light Decay with Distance.

Example 1.9.1 Some students measured the intensity of light from a 12 volt light bulb with 0.5 amp current at varying distances from the light bulb. The light decreases as the distance from the bulb increases, as shown in Figure 1.21A.

If the data are transformed as shown in Figure 1.21B then they become very interesting. For each point, (d, I) of Figure 1.21A, the point $(1/d^2, I)$ is plotted in Figure 1.21B. *Light intensity vs the reciprocal of the square of the distance from the light source* is shown. It looks pretty linear.

Explore 1.9.1 a. One data point is omitted from Figure 1.21B. Compute the entry and plot the corresponding point on the graph. Note the factor $\times 10^{-3}$ on the horizontal scale. The point 2.5 on the horizontal scale is actually $2.5 \times 10^{-3} = 0.0025$.

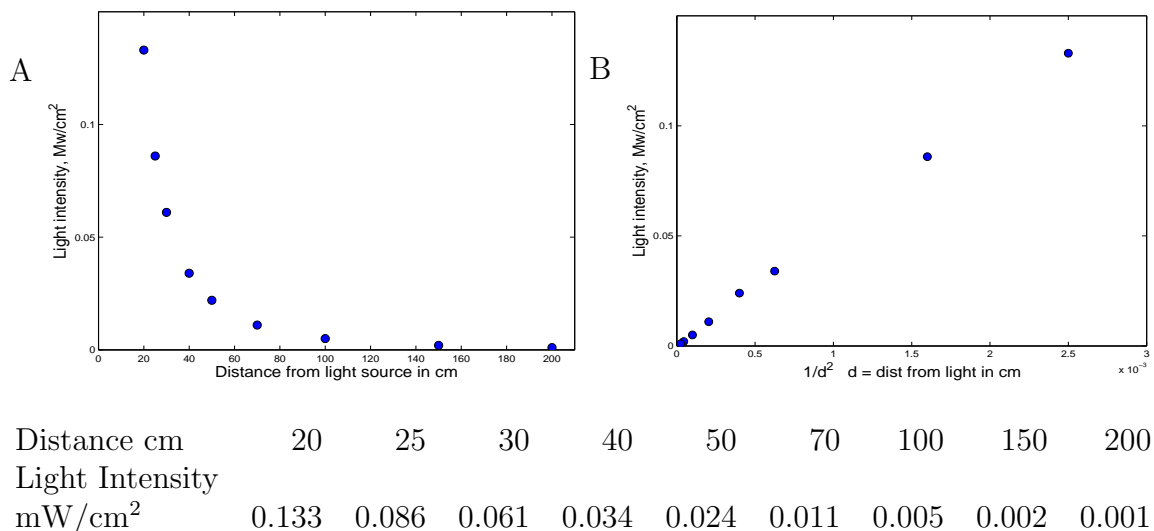

Figure 1.21: A. Light intensity *vs* distance from light source. B. Light intensity *vs* the reciprocal of the square of the distance from the light source. The light intensity is measured with a Texas Instruments Calculator Based Laboratory (CBL) which is calibrated in milliwatts/cm² = mW/cm².

- b. Explain why it would be reasonable for some points on the graph to be close to (0,0) in Figure 1.21B.
- c. Is (0,0) a possible data point for Figure 1.21B?

■

It appears that we have found an interesting relation between light intensity and distance from a light source. In the rest of this section we will examine the geometry of light emission and see a fundamental reason suggesting that this relation would be expected. ■

In Section 1.3 we saw that sunlight decayed exponentially with depth in the ocean. In Example 1.9.1 we saw that light decreased proportional to the reciprocal of the square of the distance from the light source. These two cases are distinguished by the model of light decrease, and the crux of the problem is the definition of light intensity, and how the geometry of the two cases affects light transmission, and the medium through which the light travels.

Light Intensity. Light intensity from a certain direction is defined to be the number of photons per second crossing a square meter region that is perpendicular to the chosen direction.

The numerical value of light intensity as just defined is generally large – outside our range of experience – and may be divided by a similarly large number to yield a measurement more practical to use. For example, some scientists divide by Avagadro’s number, $6.023 \cdot 10^{23}$. A more standard way is to convert photons to energy and photons per second to watts and express light intensity in watts per meter squared.

Light rays emanating from a point source expand radially from the source. Because of the distance between the sun and Earth, sun light strikes the Earth in essentially parallel rays and light intensity remains constant along the light path, except for the interference from substance along the path.

When light is measured ‘close to’ a point source, however, the light rays expand and light intensity decreases as the observer moves away from the source. Consider a cone with vertex V at a point source of light. The number of photons per second traveling outward within the solid is cone constant. As can be seen in Figure 1.22, however, because the areas of surfaces stretching across the cone expand as the distance from the source increases, the density of photons striking the surfaces decreases.

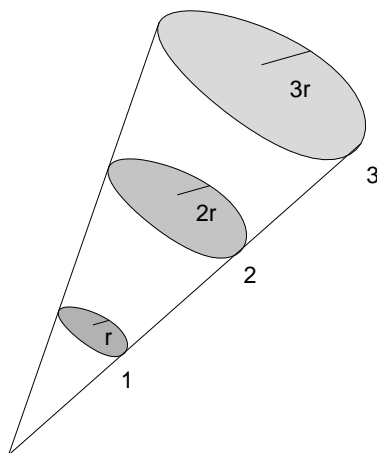

Figure 1.22: Light expansion in a cone.

Mathematical Model 1.9.1 Light Expansion: For light emanating uniformly from a point source and traveling in a solid cone, the number of photons per second crossing the surface of a sphere with center at the vertex of the cone is a constant, N , that is, independent of the radius of the sphere.

Because light intensity is ‘number of photons per second per square meter of surface’ we have

$$N = I_d A_d \quad (1.31)$$

where

- N is photons per second in a solid cone emanating from a light source at the vertex of the cone.
- d is distance from the light source.
- I_d is light intensity at distance d .
- A_d is the area of the intersection with the cone of the surface of a sphere of radius d and center at the vertex of the cone.

Illustrated in Figure 1.23 is a cone with vertex V , a sphere with center V and radius d and the portion of the surface of the sphere that lies within the cone. If the vertex angle is α then

$$A_d = \text{Area} = 2\pi (1 - \cos \alpha) d^2$$

Therefore in $N = I_d A_d$

$$N = I_d 2\pi (1 - \cos \alpha) d^2$$

or

$$I_d = K \frac{1}{d^2}$$

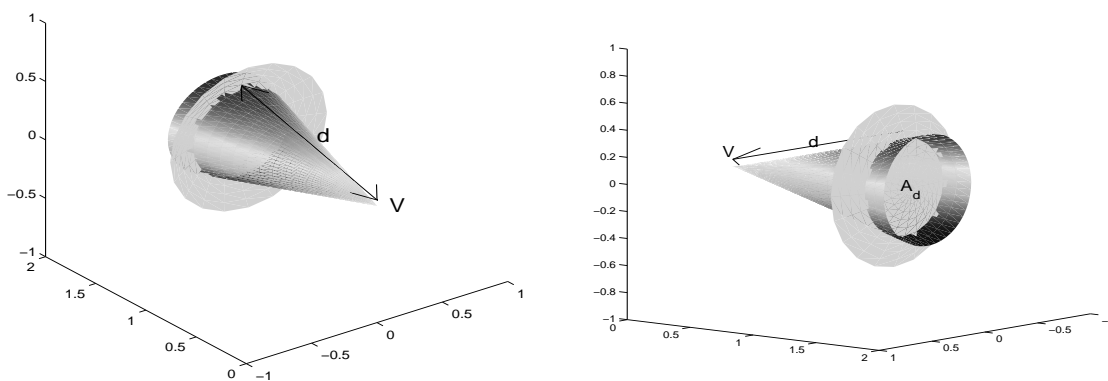

Figure 1.23: Two views of a cone and section of a sphere with center at the vertex of the cone.

Thus it is not a surprise that in Example 1.9.1, the intensity of light emanating from the 12 volt, 0.5 amp bulb was proportional to the reciprocal of the square of the light intensity.

For light emanating from a point source, the light intensity on the surface of a sphere with center at the point source and radius d is a constant, that is, the light intensity is the same at any two points of the sphere.

Exercise 1.9.1 Shown in Table 1.9.1 is data showing how light intensity from a linear light source decreases as distance from the light increases. Card board was taped on the only window in a room so that a one centimeter wide vertical slit of length 118 cm was left open. For this experiment, we considered 118 cm slit to be an infinitely long line of light. Other lights in the room were cut off. A light meter was pointed horizontally towards the center of the slit, 56 cm above the bottom of the slit, and light intensity was measured as the light meter was moved away from the window.

- This experiment is easy to replicate. Try and use your own data for the next two parts. Best to have either a clear day or an overcast day; constant sunlight is needed.
- Light emitted from a point surface is constant on surfaces of spheres with center at the light source. On which surfaces would you expect the intensity of light emitted from a linear source be constant?
- (You may wish to do the next part before this one.) Explore the data and see whether you can find a relation between light intensity and some aspect of distance.
- Formulate a model of how light decays with distance from a slit light source and relate your model to your observed relation.

Table for Exercise 1.9.1 Light intensity from a 1 cm strip of light measured at distances perpendicular to the strip.

Distance (cm)	3	4	5	6	7	8	9
Light Intensity mW/cm ²	0.474	0.369	0.295	0.241	0.208	0.180	0.159
Distance (cm)	10	11	12	13	14	15	16
Light Intensity mW/cm ²	0.146	0.132	0.120	0.111	0.100	0.092	0.086

1.10 Data modeling vs mathematical models.

In Example 1.9.1 of light intensity from a 12 volt bulb we modeled data and only subsequently built a mathematical model of light decrease from a point source of light. There are other examples of modeling of data that are interesting but there is very little possibility of building a mathematical model to explain the process. **See Also:**

http://mathinsight.org/data_modeling_versus_mathematical_modeling

Example 1.10.1 Jack A. Wolfe¹⁴ observed that leaves of trees growing in cold climates tend to be incised (have ragged edges) and leaves of trees growing in warm climates tend to have smooth edges (lacking lobes or teeth). He measured the percentages of species that have smooth margins among all species of the flora in many locations in eastern Asia. His data, as read from a graph in U. S. Geological Survey Professional Paper 1106, is presented in Figure 1.10.0.2.

Figure for Example 1.10.0.2 Average temperature C° vs percentage of tree species with smooth edge leaves in 33 forests in eastern Asia. The equation of the line is $y = -0.89 + 0.313x$.

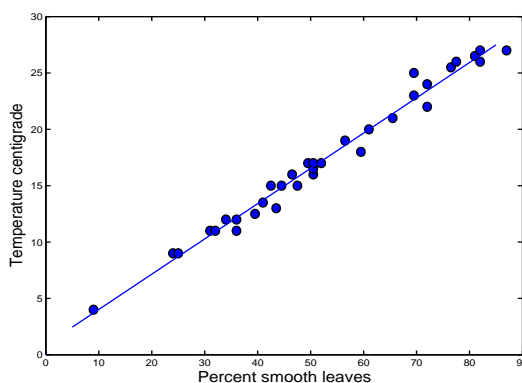

The line, $\text{temp} = 0.89 + 0.313 \%$ smooth is shown in Figure 1.10.0.2 and is close to the data. The line was used by Wolfe to estimate temperatures over the last 65 million years based on observed fossil leaf composition (Exercise 1.10.1). The prospects of writing a mathematical model describing the relationship of smooth edge leaves to temperature are slim, however. ■

Example 1.10.1 On several nights during August and September in Ames, Iowa, some students listened to crickets chirping. They counted the number of chirps in a minute (chirp rate, R) and also recorded the air (ambient) temperature (T) in F° for the night. The data were collected between 9:30 and 10:00 pm each night, and are shown in the table and graph in Figure 1.24.

¹⁴Jack A. Wolfe, A paleobotanical interpretation of tertiary climates in northern hemisphere, *American Scientist* 66 (1979), 694-703

Temperature °F T	Chirps per Minute R
67	109
73	136
78	160
61	87
66	103
66	102
67	108
77	154
74	144
76	150

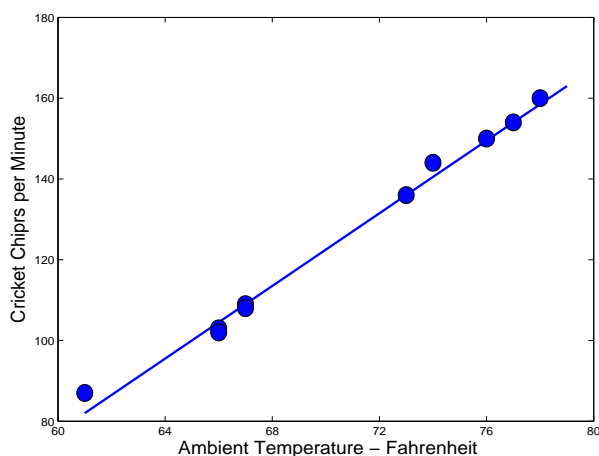

Figure 1.24: A table and graph of the frequency of cricket chirps *vs* temperature in degrees F°.

These data also appear linear and the line through (65,100) and (75,145),

$$\frac{R - 100}{T - 65} = \frac{145 - 100}{75 - 65}, \quad R = 4.5T - 192.5 \tag{1.32}$$

lies close to the data. We can use the line to estimate temperature to be about 69.5 F° if cricket chirp rate is 120 chirps/minute.

This observation was made by Amos Dolbear in 1897, see *National Geographic* July 2012, **222** (1), p 17 ff. ■

Both of these examples are examples of data modeling. We fit a line to the data, but there is no underlying explanation of what mechanism is causing the relation.

Exercises for Section 1.10, Data modeling *vs* mathematical models.

Exercise 1.10.1 Jack Wolfe applied his data (Figure 1.10.0.2) to resolve a dispute about estimates of ambient temperatures during the last 65 million years. Fossil leaves from strata ranging in age back to 65 million years were examined for the percent of smooth-leaved species in each stratum. Under the hypothesis that the relation between percent of smooth-leaved species and temperature in modern species persisted over the last 65 million years, he was able to estimate the past temperatures. Your job is to replicate his work. Although Wolfe collected fossil leaf data from four locations ranging from southern Alaska to Mississippi, we show only his data from the Pacific Northwest, in Table Ex. 1.10.1, read from a graph in Wolfe’s article in *American Scientist* 1979, 66:694-703.

Use the Percent Smooth data for the fossil leaves at previous times in Table Ex. 1.10.1, and the modern relation, $\text{temp} = 0.89 + 0.313 \% \text{ smooth}$, to draw a graph showing the history of ambient temperature for the land of the Pacific Northwest

- a. Over the period from 50 to 40 million years ago.
- b. Over the period from 35 to 26 million years ago.

- c. Over the period from 26 to 16 million years ago.
- d. Over the period from 16 to 6 million years ago.

Table for Exercise 1.10.1 Percentages of smooth-leaved species found in geological strata in the Pacific Northwest.

Age Myr	Percent Smooth	Age Myr	Percent Smooth	Age Myr	Percent Smooth	Age Myr	Percent Smooth
50	57	35	66	26	42	10	28
48	50	35	68	21	24	10	30
48	51	33	55	21	28	10	32
44	70	31	24	21	32	6	34
44	74	31	32	16	31	6	38
40	40	26	32	16	34		
40	44	26	40	16	38		

- Exercise 1.10.2**
- a. Use the graph in Figure 1.24 to estimate the expected temperature if the cricket chirp rate were 95 chirps per minute? Also use Equation 1.32 to compute the same temperature and compare your results.
 - b. On the basis of Equation 1.32, what cricket chirp frequencies might be expected for the temperatures 110 °F and 40 °F? Discuss your answers in terms of the data in Figure 1.24 and the interval on which the equation is valid.
 - c. A television report stated that in order to tell the temperature, count the number of cricket chirps in 13 seconds and add 40. The result will be the temperature in Fahrenheit degrees. Is that consistent with Equation 1.32? (Suggestion: Solve for Temperature °F in terms of Cricket Chirps per Minute.)

Exercise 1.10.3 Some students made a small hole near the bottom of the cylindrical section of a two-liter plastic beverage container, held a finger over the hole and filled the container with water to the top of the cylindrical section, at 15.3 cm. The small hole was uncovered and the students marked the height of the water remaining in the tube, reported here at eighty-second intervals, until the water ran out. They then measured the heights of the marks above the hole. The data gathered and a graph of the data are shown in Figure 1.25.

- a. Select a curve and fit an equation for the curve to the data in Figure 1.25.
- b. Search your physics book for a mathematical model that explains the data. A fluid dynamicist named Evangelista Torricelli (1608-1649) provided such a model (and also invented the mercury thermometer).
- c. The basic idea of Torricelli’s formula is that the potential energy of a thin layer of liquid at the top of the column is converted to kinetic energy of fluid flowing out of the hole.

Let the time index, t_0, t_1, \dots measure minutes and h_k be the height of the water at time t_k . The layer between h_k and h_{k+1} has mass m_k and potential energy m_kgh_k . During the k th

Time sec	Height cm
0	15.3
80	12.6
160	9.9
240	7.8
320	6.2
400	4.3
480	3.1
560	2.0

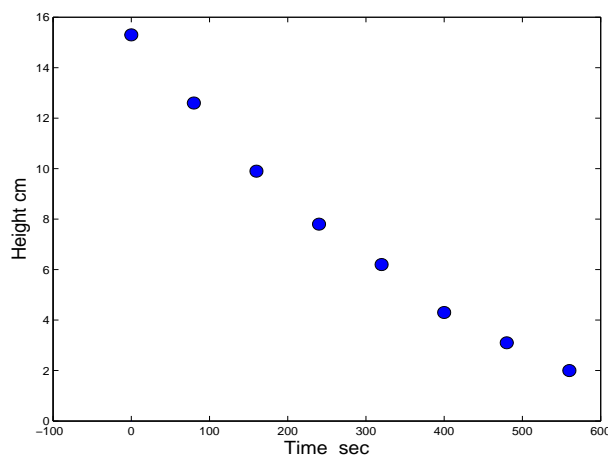

Figure 1.25: Height of water draining from a 2-liter beverage container measured at 40 second intervals.

minute an equal mass and volume of water flows out of the hole with velocity, v_k , and kinetic energy $\frac{1}{2}m_k v_k^2$. Equating potential and kinetic energies,

$$m_k g h_k = \frac{1}{2} m_k v_k^2, \quad g h_k = \frac{1}{2} v_k^2$$

Let A_{cylinder} and A_{hole} be the cross-sectional areas of the cylinder and hole, respectively.

1. Argue that

$$v_k = \frac{A_{\text{cylinder}}}{A_{\text{hole}}} \frac{h_k - h_{k+1}}{t_{k+1} - t_k} = \frac{A_{\text{cylinder}}}{A_{\text{hole}}} (h_k - h_{k+1})$$

2. Argue that

$$h_{k+1} = h_k - K \sqrt{h_k} \tag{1.33}$$

where K is a constant.

3. Compare Equation 1.33 with Equation 1.18

1.11 Summary

You have begun one of the most important activities in science, the writing of mathematical models. The best models are sufficiently detailed in their description that **dynamic equations** describing the progress of the underlying system can be written and lead to **solution equations** that describe the overall behavior. In our models there was a quantity (Q) that changed with either time or distance (v) and the dynamic equation specified how the change in Q , $Q_{v+1} - Q_v$, depended on Q or v . The solution equation explicitly expressed the relation of Q to v .

In some cases, such as the case of cricket chirp frequency dependence on ambient temperature in Example 1.10.1, the underlying mechanism is too complex to model it. The observation, however, stimulates considerable thought about why it should be. Presumably the metabolism of the cricket increases with temperature thus causing an increase in chirp frequency, but the phrase, ‘metabolism of the cricket’, masks a large complexity.

We have generally followed certain steps in developing our models. They are useful steps but by no means do they capture the way to model the biological universe. The modeling process is varied and has to be adapted to the questions at hand.

By the methods of this chapter you can solve every *first order linear finite difference equation with constant coefficients*:

$$y_0 \text{ given, } \quad y_{t+1} - y_t = r y_t + b \quad (1.34)$$

The solution is

$$y_t = -\frac{b}{r} + \left(y_0 + \frac{b}{r}\right) (r+1)^t \quad \text{if } r \neq 0, \quad \text{or} \quad y_t = y_0 + t b \quad \text{if } r = 0.$$

Exercises for Chapter 1, Mathematical Models of Biological Processes.

Chapter Exercise 1.11.1 Two kilos of a fish poison, rotenone, are mixed into a lake which has a volume of $100 \times 20 \times 2 = 4000$ cubic meters. No water flows into or out of the lake. Fifteen percent of the rotenone decomposes each day.

- Write a mathematical model that describes the daily change in the amount of rotenone in the lake.
- Let R_0, P_1, R_2, \dots denote the amounts of rotenone in the lake, P_t being the amount of poison in the lake at the beginning of the t th day after the rotenone is administered. Write a dynamic equation representative of the mathematical model.
- What is R_0 ? Compute R_1 from your dynamic equation. Compute R_2 from your dynamic equation.
- Find a solution equation for your dynamic equation.

Note: Rotenone is extracted from the roots of tropical plants and in addition to its use in killing fish populations is used as a insecticide on such plants as tomatoes, pears, apples, roses, and African violets. Studies in which large amounts (2 to 3 mg/Kg body weight) of rotenone were injected into the jugular veins of laboratory rats produced symptoms of Parkinson's disease, including the reduction of dopamine producing cells in the brain. (Benoit I. Giasson & Virginia M.-Y. Lee, A new link between pesticides and Parkinson's disease, *Nature Neuroscience* 3, 1227 - 1228 (2000)).

Chapter Exercise 1.11.2 Two kilos of a fish poison *that does not decompose* are mixed into a lake that has a volume of $100 \times 20 \times 2 = 4000$ cubic meters. A stream of clean water flows into the lake at a rate of 1000 cubic meters per day. Assume that it mixes immediately throughout the whole lake. Another stream flows out of the lake at a rate of 1000 cubic meters per day.

- Write a mathematical model that describes the daily change in the amount of poison in the lake.
- Let P_0, P_1, P_2, \dots denote the amounts of poison in the lake, P_t being the amount of poison in the lake at the beginning of the t th day after the poison is administered. Write a dynamic equation representative of the mathematical model.
- What is P_0 ? Compute P_1 from your dynamic equation. Compute P_2 from your dynamic equation.
- Find a solution equation for your dynamic equation.

Chapter Exercise 1.11.3 Two kilos of rotenone are mixed into a lake which has a volume of $100 \times 20 \times 2 = 4000$ cubic meters. A stream of clean water flows into the lake at a rate of 1000 cubic meters per day. Assume that it mixes immediately throughout the whole lake. Another stream flows out of the lake at a rate of 1000 cubic meters per day. Fifteen percent of the rotenone decomposes every day.

- Write a mathematical model that describes the daily change in the amount of rotenone in the lake.
- Let R_0, R_1, R_2, \dots denote the amounts of rotenone in the lake, R_t being the amount of rotenone in the lake at the beginning of the t th day after the poison is administered. Write a dynamic equation representative of the mathematical model.
- What is R_0 ? Compute R_1 from your dynamic equation. Compute R_2 from your dynamic equation.
- Find a solution equation for your dynamic equation.

Chapter Exercise 1.11.4 Consider a chemical reaction

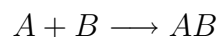

in which a chemical, A , combines with a chemical, B , to form the compound, AB . Assume that the amount of B greatly exceeds the amount of A , and that in any second, the amount of AB that is formed is proportional to the amount of A present at the beginning of the second. Write a dynamic equation for this reaction, and write a solution equation to the dynamic equation.

Chapter Exercise 1.11.5 An egg is covered by a hen and is at 37° C. The hen leaves the nest and the egg is exposed to 17° C air. After 20 minutes the egg is at 34° C.

Draw a graph representative of the temperature of the egg t minutes after the hen leaves the nest.

Mathematical Model. During any short time interval while the egg is uncovered, the decrease in egg temperature is proportional to the difference between the egg temperature and the air temperature.

- Introduce notation and write a dynamic equation representative of the mathematical model.
- Write a solution equation for your dynamic equation.
- Your dynamic equation should have one parameter. Use the data of the problem to estimate the parameter.

Chapter Exercise 1.11.6 The length of an burr oak leaf was measured on successive days in May. The data are shown in Table 1.5. Select an appropriate equation to approximate the data and compute the coefficients of your equation. Do you have a mathematical model of leaf growth?

Chapter Exercise 1.11.7 Atmospheric pressure decreases with increasing altitude. Derive a dynamic equation from the following mathematical model, solve the dynamic equation, and use the data to evaluate the parameters of the solution equation.

Table 1.5: Length of a burr oak leaf.

Day	May 7	May 8	May 9	May 10	May 11
Length mm	67	75	85	98	113

Mathematical Model 1.11.1 Mathematical Model of Atmospheric Pressure. Consider a vertical column of air based at sea level divided at intervals of 10 meters and assume that the temperature of the air within the column is constant, say 20°C. The pressure at any height is the weight of air in the column above that height divided by the cross sectional area of the column. In a 10-meter section of the column, by the ideal gas law the the mass of air within the section is proportional to the product of the volume of the section and the pressure within the section (which may be considered constant and equal to the pressure at the bottom of the section). The weight of the air above the lower height is the weight of air in the section plus the weight of air above the upper height.

Sea-level atmospheric pressure is 1 atm and the pressure at 18,000 feet is one-half that at sea level (an easy to remember datum from NASA).

Figure for Exercise 1.11.7 Figure for Exercise 1.11.7.

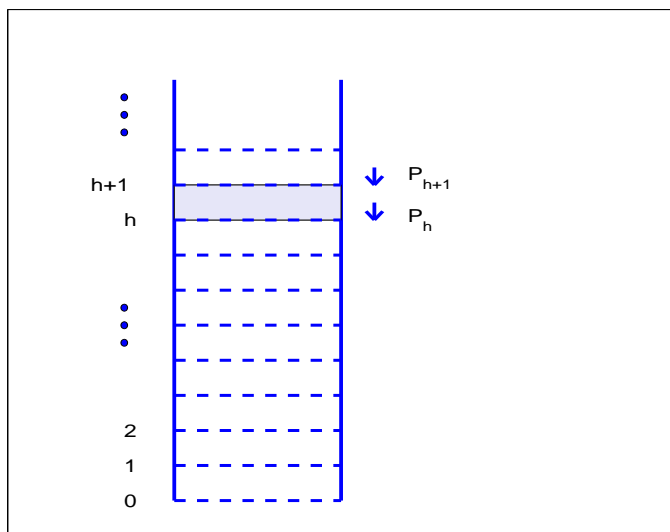

Chapter 2

Functions as Descriptions of Biological Patterns.

Where are we going?

Relations between quantities are so central to science and mathematics that the concept has been carefully defined and is named *function*. You will see how tables of data, graphs, and equations are unified into a single concept, function. This chapter will present examples of some unusual relations between quantities that suggest the usefulness of the general concept, and it will introduce three definitions of **function** with increasing levels of precision.

Electrocardiograms are examples of relations between voltage and time that are functions. Equations to describe the relation are difficult to find, and once found, are not informative. It is better to think of each trace as simply a function.



Many biological relations may be described by equations — linear, quadratic, hyperbolic, exponential, and logarithmic. These together with the trigonometric equations cover most of the commonly encountered equations. Scientific calculators readily compute these values that in the past were laboriously computed by hand and recorded in lengthy tables. There are some relations between measured quantities that are not so easily described by equations, and in this chapter we see how we can extend the use of equations to describe relations to a general concept referred to as a **function**. Formal definitions of *function* and ways of combining functions are presented.

2.1 Environmental Sex Determination in Turtles

It is a well known, but little understood fact that the sex of some reptiles depends on the environment in which the egg is incubated (temperature is important), and is not purely a genetic

determination. A graph of some data on a species of fresh water turtles appears in Figure 2.1¹.

Explore 2.1.1 Examine the graph for *Chrysemys picta* and write a brief verbal description of the dependence of the percentage of females on incubation temperature for a clutch of *Chrysemys picta* eggs.

■

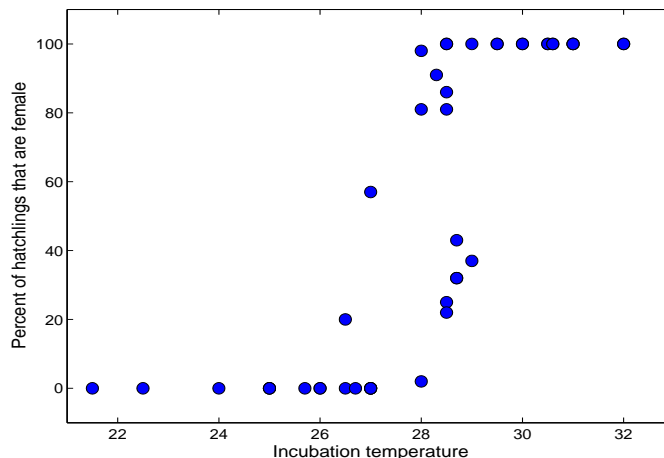

Figure 2.1: Percent female hatchlings from incubation of *Chrysemys picta* eggs at various temperatures.

Your experience probably does not include a single analytic formula that describes the dependence of the percentage of females on incubation temperature for a clutch of turtle eggs. It is easiest to use a *piecewise* definition; use one formula for a range of temperatures and other formulas for other ranges of temperatures. Your verbal description in the case of *Chrysemys picta* could say that if the temperature is less than 28 °C, the percent of female is zero, and if the temperature is greater than or equal to 29 °C, the percent of female is 100. One could describe what happens between 28 °C and 29 °C, but the accuracy of the data probably does not warrant such a refinement. This piecewise procedure of describing data occurs often enough to have a special notation.

$$\text{Percent of hatchlings that are female} = \begin{cases} 0 & \text{if Temp} < 28 \text{ }^\circ\text{C} \\ \text{Uncertain} & \text{if } 28 \text{ }^\circ\text{C} \leq \text{Temp} < 29 \text{ }^\circ\text{C} \\ 100 & \text{if } 29 \text{ }^\circ\text{C} \leq \text{Temp} \end{cases} \quad (2.1)$$

The designation Uncertain for $28 \text{ }^\circ\text{C} \leq \text{Temp} < 29 \text{ }^\circ\text{C}$ is a bit unsatisfactory but we hope the example sufficiently illustrates piecewise definition of dependence.

Exercises for Section 2.1 Environmental Sex Determination in Turtles.

¹This data was collected by Ralph Ackerman from a number of publications, most of which are referenced in, Fredric J. Janzen and Gary L. Paukstis, Environmental sex determination in reptiles: Ecology, evolution, and experimental design, *The Quarterly Review of Biology* **66** (1991) 149-179.

Exercise 2.1.1 Data on the temperature determination of sex for the snapping turtle, *Chelydra serpentina* appears in Figure Ex. 2.1.1.

- Write a verbal description of the dependence of the percentage of females on incubation temperature for a clutch of *Chelydra serpentina* eggs.
- Write formulas similar to Formulas 2.1 to describe the dependence of the percentage of females on incubation temperature for a clutch of *Chelydra serpentina* eggs.

Figure for Exercise 2.1.1 Percent females from clutches of *Chelydra serpentina* (snapping turtle) eggs incubated at various temperatures.

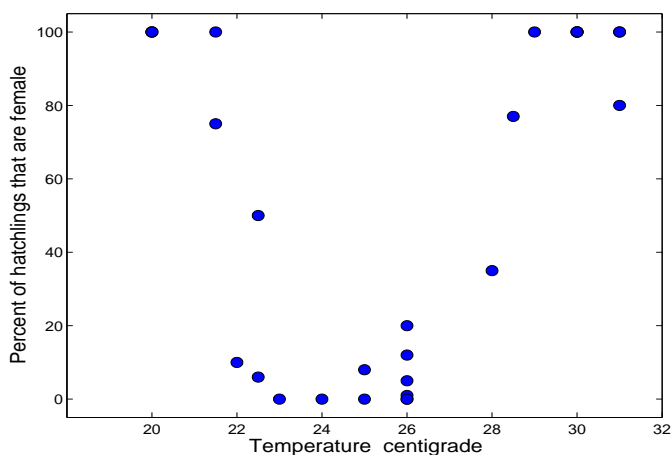

2.2 Functions and Simple Graphs.

A large part of science may be described as the study of the dependence of one measured quantity on another measured quantity. The word *function* is used in this context in a special way. In previous examples, the word *function* may have been used as follows:

- The density of *V. natriegens* is a *function* of time.
- Light intensity is a *function* of depth below the surface in an ocean.
- Light intensity is a *function* of distance from the light source.
- The frequency of cricket chirps is a *function* of the ambient temperature.
- The percentage of females turtles from a clutch of eggs is a *function* of the incubation temperature.

2.2.1 Three definitions of “Function”.

Because of its prevalence and importance in science and mathematics, the word *function* has been defined several ways over the past three hundred years, and now is usually given a very precise formal meaning. More intuitive meanings are also helpful and we give three definitions of function, all of which will be useful to us.

The word *variable* means a symbol that represents any member of a given set, most often a set of numbers, and usually denotes a value of a measured quantity. Thus density of *V. natriegens*,

time, percentage of females, incubation temperature, light intensity, depth and distance are all variables.

The terms *dependent* variable and *independent* variable are useful in the description of an experiment and the resulting functional relationship. The density of *V. natriegens* (dependent variable) is a function of time (independent variable). The percentage of females turtles from a clutch of eggs (dependent variable) is a *function* of the incubation temperature (independent variable).

Using the notion of variable, a function may be defined:

Definition 2.2.1 Function I *Given two variables, x and y , a function is a rule that assigns to each value of x a unique value of y .*

In this context, x is the *independent variable*, and y is the *dependent variable*. In some cases there is an equation that nicely describes the ‘rule’; in the percentage of females in a clutch of turtle eggs examples of the preceding section, there was not a simple equation that described the rule, but the rule met the definition of function, nevertheless.

The use of the words dependent and independent in describing variables may change with the context of the experiment and resulting function. For example, the data on the incubation of turtles implicitly assumed that the temperature was held constant during incubation. For turtles in the wild, however, temperature is not held constant and one might measure the temperature of a clutch of eggs as a function of time. Then, temperature becomes the dependent variable and time is the independent variable.

In Definition 2.2.1, the word ‘variable’ is a bit vague, and ‘a function is a rule’ leaves a question as to ‘What is a rule?’. A ‘set of objects’ or, equivalently, a ‘collection of objects’, is considered to be easier to understand than ‘variable’ and has broader concurrence as to its meaning. Your previous experience with the word *function* may have been that

Definition 2.2.2 Function II *A function is a rule that assigns to each number in a set called the domain a unique number in a set called the range of the function.*

Definition 2.2.2 is similar to Definition 2.2.1, except that ‘a number in a set called the domain’ has given meaning to *independent variable* and ‘a unique number in a set called the range’ has given meaning to *dependent variable*.

The word ‘rule’ is at the core of both definitions 2.2.1 **Function I.** and 2.2.2 **Function II.** and is still a bit vague. The definition of function currently considered to be the most concise is:

Definition 2.2.3 Function III *A function is a collection of ordered number pairs no two of which have the same first number.*

A little reflection will reveal that ‘a table of data’ is the motivation for Definition 2.2.3. A data point is actually a number pair. Consider the tables of data shown in Table 2.1 from *V. natriegens* growth and human population records. (16,0.036) is a data point. (64,0.169) is a data point. (1950,2.52) and (1980,4.45) are data points. These are basic bits of information for the functions. On the other hand, examine the data for cricket chirps in the same table, from Chapter 1. That also is a collection of ordered pairs, but the collection does not satisfy Definition 2.2.3. There are two ordered pairs in the table with the same first term – (66,102) and (66,103). Therefore the collection contains important information about the dependence of chirp frequency on temperature, although the collection does not constitute a function.

In a function that is a collection of ordered number pairs, the first number of a number pair is always a value of the independent variable and a member of the domain and the second number is

Table 2.1: Examples of tables of data

V. natriegens Growth pH 6.25	
Time (min)	Population Density
0	0.022
16	0.036
32	0.060
48	0.101
64	0.169
80	0.266

World Population	
Year	Population (billions)
1940	2.30
1950	2.52
1960	3.02
1970	3.70
1980	4.45
1990	5.30
2000	6.06

Cricket Chirps	
Temper- ature °F	Chirps per Minute
67	109
73	136
78	160
61	87
66	103
66	102
67	108
77	154
74	144
76	150

always a value of the dependent variable and a member of the range. Almost always in recording the results of an experiment, the numbers in the domain are listed in the column on the left and the numbers in the range are listed in the column on the right. Formally,

Definition 2.2.4 Domain and Range For Definition 2.2.3 of function, the **domain** is defined as the set of all numbers that occur as the first number in an ordered pair of the function and the **range** of the function is the set of all numbers that occur as a second number in an ordered pair of the function.

Example 2.2.1 Data for the percentage of U.S. population in 1955 that had antibodies to the polio virus as a function of age is shown in Table 2.2.1.1. The data show an interesting fact that a high percentage of the population in 1955 had been infected with polio. A much smaller percentage were crippled or killed by the disease.

Although Table 2.2.1.1 is a function, it is only an approximation to a **perhaps** real underlying function. The order pair, (17.5, 72), signals that 72 percent of the people of age 17.5 years had antibodies to the polio virus. More accurately, (17.5,72) signals that of a **sample** of people who had ages in the interval from age 15 to less than 20, the percentage who tested positive to antibodies to the polio virus was greater than or equal to 71.5 and less than 72.5.

Table 2.2.1.1 is a useful representation of an enormous table of data that lists **for a certain instance of time during 1955**, for each U.S. citizen, their age (measured perhaps in hours (minutes?, seconds?)), and whether they had HIV antibodies, 'yes' or 'no,' This table would not be a function, but for each age, the percent of people of that age who were HIV positive would be a number and those age-percent pairs would form a function. The domain of that function would be the finite set of ages in the U.S. population.



Table for Example 2.2.1.1 Data for percentage of the U.S. population in 1955 at various ages that had antibodies to the polio virus. Data read from Anderson and May, Vaccination and herd immunity to infectious diseases, *Nature* **318** 1985, pp 323-9, Figure 2f.

Age	0.8	1.5	2.5	3.5	4.5	5.5	6.5	7.5	8.5	9.5	12.5	17.5	22.5	27.5
%	3	6	13	19	27	35	40	43	46	49	64	72	78	87

Remember that only a very few data ‘points’ were listed from the large number of possible points in each of the experiments we considered. There is a larger function in the background of each experiment.

Because many biological quantities change with time, the domain of a function of interest is often an interval of time. In some cases a biological reaction depends on temperature (percentage of females in a clutch of turtle eggs for example) so that the domain of a function may be an interval of temperatures. In cases of spatial distribution of a disease or light intensity below the surface of a lake, the domain may be an interval of distances.

It is implicit in the bacteria growth data that at any specific time, there is only one value of the bacterial density² associated with that time. It may be incorrectly or inaccurately read, but a fundamental assumption is that there is only one correct density for that specific time. The condition that no two of the ordered number pairs have the same first term is a way of saying that each number in the domain has a unique number in the range associated with it.

All three of the definitions of *function* are helpful, as are brief verbal descriptions, and we will rely on all of them. Our basic definition, however, is the ordered pair definition, Definition 2.2.3.

2.2.2 Simple graphs.

Coordinate geometry associates ordered number pairs with points of the plane so that by Definition 2.2.3 a function is automatically identified with a point set in the plane called a *simple graph*:

Definition 2.2.5 Simple Graph *A simple graph is a point set, G , in the plane such that no vertical line contains two points of G .*

*The **domain** of G is the set of x -coordinates of points of G and the **range** of G is the set of all y -coordinates of points of G .*

Note: For use in this book, every set contains at least one element.

The domain of a simple graph G is sometimes called the x -projection of G , meaning the vertical projection of G onto the x -axis and the range of G is sometimes called the y -projection of G meaning the horizontal projection of G onto the y -axis.

A review of the graphs of incubation temperature - percentage of females turtles in Figure 2.1 and Exercise Fig. 2.1.1 will show that in each graph at least one vertical line contains two points of the graph. Neither of these graphs is a simple graph, but the graphs convey useful information.

A circle is not a simple graph. As shown in Figure 2.2A there is a vertical line that contains two points of it. There are a lot of such vertical lines. The circle does contain a simple graph, and

²As measured, for example, by light absorbance in a spectrophotometer as discussed on page 4

contains one that is ‘as large as possible’. The upper semicircle shown in Figure 2.2B is a simple graph. The points $(-1,0)$ and $(1,0)$ are filled to show that they belong to it. It is impossible to add any other points of the circle to this simple graph and still have a simple graph — thus it is ‘as large as possible’. An equation of the upper semicircle is

$$y = \sqrt{1 - x^2}, \quad -1 \leq x \leq 1$$

The domain of this simple graph is $[-1,1]$, and the range is $[0,1]$. Obviously the lower semicircle is a maximal simple graph also, and it has the equation

$$y = -\sqrt{1 - x^2}, \quad -1 \leq x \leq 1$$

The domain is again $[-1,1]$, and the range is $[-1,0]$.

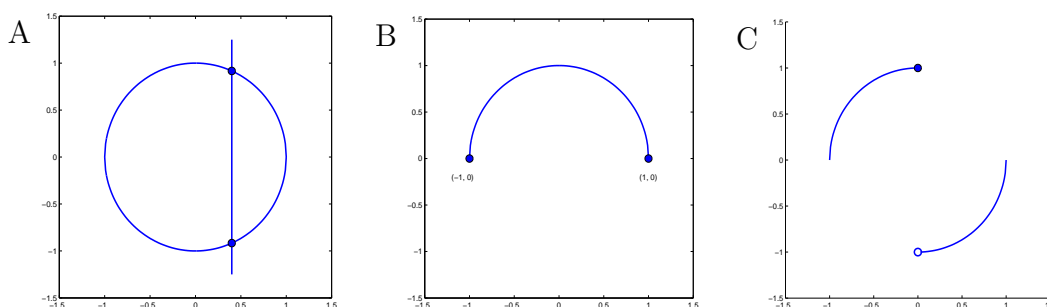

Figure 2.2: A. A circle; a vertical line contains two point of the circle so that it is not a simple graph. B. A subset of the circle that is a simple graph. C. Another subset of the circle that is a simple graph. The simple graphs in (b) and (c) are maximal in the sense that any point from the circle added to the graphs would create a set that is not a simple graph — the vertical line containing that point would also contain a point from the original simple graph.

There is yet a third simple graph contained in the circle, shown in Figure 2.2C, and it is ‘as large as possible’. An equation for that simple graph is

$$y = \begin{cases} \sqrt{1 - x^2} & \text{if } -1 \leq x \leq 0 \\ -\sqrt{1 - x^2} & \text{if } 0 < x \leq 1 \end{cases}$$

The domain is $[-1,1]$ and range is $[-1,1]$ Because of the intuitive advantage of geometry, it is often useful to use simple graphs instead of equations or tables to describe functions, but again, we will use any of these as needed.

Exercises for Section 2.2 Functions and Simple Graphs.

Exercise 2.2.1 Which of the tables shown in Table Ex. 2.2.1 reported as data describing the growth of *V. natriegens* are functions?

Table for Exercise 2.2.1 Hypothetical data for *V. natriegens* growing in Nutrient Broth.

Time	Abs	Time	Abs	Time	Abs
0	0.018	0	0.018	0	0.018
12	0.023	12	0.023	12	0.023
24	0.030	24	0.030	24	0.030
36	0.039	36	0.039	48	0.049
48	0.049	48	0.049	48	0.049
48	0.065	60	0.065	48	0.049
60	0.085	72	0.065	72	0.065
78	0.120	87	0.065	87	0.065
96	0.145	96	0.080	96	0.080
110	0.195	110	0.095	110	0.095
120	0.240	120	0.120	120	0.120

Exercise 2.2.2 For the following experiments, determine the independent variable and the dependent variable, and draw a simple graph or give a brief verbal description (your best guess) of the function relating the two.

- A rabbit population size is a function of the number of coyotes in the region.
- An agronomist, interested in the most economical rate of nitrogen application to corn, measures the corn yield in test plots using eight different levels of nitrogen application.
- An enzyme, E, catalyzes a reaction converting a substrate, S, to a product P according to



Assume enzyme concentration, [E], is fixed. A scientist measures the rate at which the product P accumulates at different concentrations, [S], of substrate.

- A scientist titrates a 0.1 M solution of HCl into 5 ml of an unknown basic solution containing litmus (litmus causes the color of the solution to change as the pH changes).

Exercise 2.2.3 A table for bacterial density for growth of *V. natriegens* is repeated in Exercise Table 2.2.3. There are two functions that relate population density to time in this table, one that relates population density to time and another that relates population to time index.

- Identify an ordered pair that belongs to both functions.
- One of the functions is implicitly only a partial list of the order pairs that belong to it. You may be of the opinion that both functions have that property, but some people may think one is more obviously only a sample of the data. Which one?
- What is the domain of the other function?

Table for Exercise 2.2.3 Data for *V. natriegens* growing in pH 6.25 nutrient broth.

pH 6.25		
Time (min)	Time Index t	Population Density B_t
0	0	0.022
16	1	0.036
32	2	0.060
48	3	0.101
64	4	0.169
80	5	0.266

Exercise 2.2.4 Refer to the graphs in Figure Ex. 2.2.4.

1. Which of the graphs are simple graphs?
2. For those that are not simple graphs,
 - (a) Draw, using only the points of the graph, a simple graph that is ‘as large as possible’, meaning that no other points can be added and still have a simple graph.
 - (b) Draw a second such simple graph.
 - (c) Identify the domains and ranges of the two simple graphs you have drawn.
 - (d) How many such simple graphs may be drawn?

Figure for Exercise 2.2.4 Graphs for Exercise 2.2.4. Some are simple graphs; some are not simple graphs.

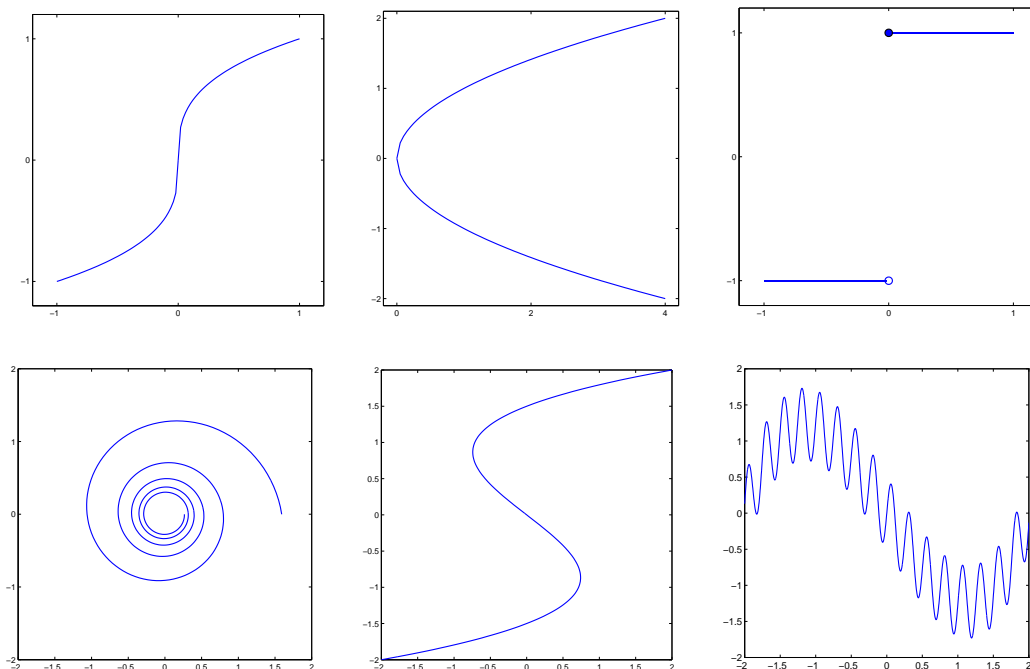

Exercise 2.2.5 Make a table showing the ordered pairs of a simple graph contained in the graph in Figure Ex. 2.2.5 and that has domain

$$\{-1.5, -1.0, -0.5, 0.0, 0.5, 1.0, 1.5\}$$

How many such simple graphs are contained in the graph of Figure Ex. 2.2.5 and that have this domain?

Figure for Exercise 2.2.5 Graph for Exercise 2.2.5.

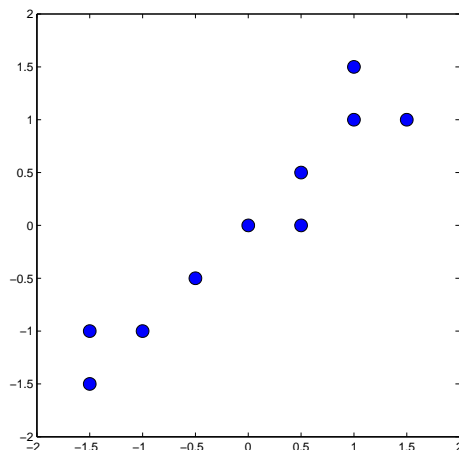

- Exercise 2.2.6**
- Does every subset of the plane contain a simple graph?
 - Does every subset of the plane contain two simple graphs?
 - Is there a subset of the plane that contains two and only two simple graphs?
 - Is there a line in the plane that is not the graph of a function?
 - Is there a function whose graph is a circle?
 - Is there a simple graph in the plane whose domain is the interval $[0,1]$ (including 0 and 1) and whose range is the interval $[0,3]$?
 - Is there a simple graph in the plane whose domain is $[0,1]$ and whose range is the y -axis?

Exercise 2.2.7 A bit of a difficult exercise. For any location, λ on Earth, let Annual Daytime at λ , $AD(\lambda)$, be the sum of the lengths of time between sunrise and sunset at λ for all of the days of the year. Find a reasonable formula for $AD(\lambda)$. You may guess or find data to suggest a reasonable formula, but we found proof of the validity of our formula a bit arduous. As often happens in mathematics, instead of solving the actual problem posed, we found it best to solve a 'nearby' problem that was more tractable. The 365.24... days in a year is a distraction, the elliptical orbit of Earth is a downright hinderance, and the wobble of Earth on its axis can be overlooked. Specifically, we find it helpful to assume that there are precisely 366 days in the year (after all this was true about 7 or 8 million years ago), the Earth's orbit about the sun is a circle, the Earth's axis makes a constant angle with the plane of the orbit, and that the rays from the sun to Earth are parallel. We hope you enjoy the question.

2.2.3 Functions in other settings.

There are extensions of the function concept to settings where the ordered pairs are not ordered *number* pairs. A prime example of this is the genetic code shown in Figure 2.3. The relation is a true function (no two ordered pairs have the same first term), and during the translation of proteins, the ribosome and the transfer RNA's use this function reliably.

1st position (5' end) ↓	2nd position				3rd position (3' end) ↓
	U	C	A	G	
U	Phe	Ser	Tyr	Cys	U
	Phe	Ser	Tyr	Cys	C
	Leu	Ser	STOP	STOP	A
	Leu	Ser	STOP	Trp	G
C	Leu	Pro	His	Arg	U
	Leu	Pro	His	Arg	C
	Leu	Pro	Gln	Arg	A
	Leu	Pro	Gln	Arg	G
A	Ile	Thr	Asn	Ser	U
	Ile	Thr	Asn	Ser	C
	Ile	Thr	Lys	Arg	A
	Met*	Thr	Lys	Arg	G
G	Val	Ala	Asp	Gly	U
	Val	Ala	Asp	Gly	C
	Val	Ala	Glu	Gly	A
	Val	Ala	Glu	Gly	G

Figure 2.3: The genetic code (for human nuclear RNA). Sets of three nucleotides in RNA (codons) are translated into amino acids in the course of proteins synthesis. CAA codes for Gln (glutamine). *AUG codes for Met (methionine) and is also the START codon.

Explore 2.2.1 List three ordered pairs of the genetic code. What is the domain of the genetic code? What is the range of the genetic code? ■

The ordered pair concept is retained in the preceding example; the only change has been in the types of objects that are in the domain and range. When the objects get too far afield from simple numbers, the word *transformation* is sometimes used in place of function. The genetic code is a transformation of the codons into amino acids and start and stop signals.

Another commonly encountered extension of the kinds of objects in the domain of a function occurs when one physical or biological quantity is dependent on two others. For example, the widely known Charles' Law in Chemistry can be stated as

$$P = \frac{nRT}{V}$$

where P = pressure in atmospheres, n = number of molecular weights of the gas, $R = 0.0820$ Atmospheres/degree Kelvin-mol = 8.3 /degree Kelvin-mol (the gas constant), T = temperature in kelvins, and V = volume in liters. For a fixed sample of gas, the pressure is dependent on two quantities, temperature and volume. The domain is the set of all feasible temperature-volume pairs, the range is the set of all feasible pressures. The function in this case is said to be a function of two variables. The ordered pairs in the function are of the form

$$((x, y), z), \quad \text{or} \quad ((\text{temperature, volume}), \text{pressure})$$

There may also be multivalued transformations. For example, doctors prescribe antibiotics. For each bacterial infection, there may be more than one antibiotic effective against that

bacterium; there may be a list of such antibiotics. The domain would be a set of bacteria, and the range would be a set of lists of antibiotics.

Exercises for Section 2.2.3 Functions in other settings.

Exercise 2.2.8 Describe the domain and range for each of the following transformations.

- Bird identification guide book.
- A judge sentences defendants to jail terms.
- The time between sunrise and sunset.
- Antibiotic side effects.

2.3 Function notation.

It is common to let a letter denote a set of ordered pairs that is a function.

If F denotes a function, then for any ordered pair, (x, y) in F , y is denoted by $F(x)$.

Thus the ordered pair $(x, F(x))$ is an ordered pair of F . The notation makes it very easy to describe a function by an equation. Instead of

'Let F be the collection of ordered number pairs to which an ordered pair (x, y) belongs if and only if x is a number and $y = x^2 + x$.'

one may write

'Let F be the function such that for all numbers x , $F(x) = x^2 + x$.'

Operationally, you will find that often you can simply replace y in an equation by $F(x)$ and define a function. Furthermore, because you are used to using y in an equation, you can often replace $F(x)$ in the definition of a function by y and use the resulting equation which is more familiar.

The following expressions all may be used in the definition of a function.

$$\begin{array}{ll}
 \text{(a)} & F(x) = x^2 \\
 \text{(b)} & F(x) = x + 5 \\
 \text{(c)} & F(x) = x + \frac{1}{x} \quad x \neq 0 \\
 \text{(d)} & F(x) = e^x \\
 \text{(e)} & F(x) = \sqrt{x} \quad x \geq 0 \\
 \text{(f)} & F(x) = \log_{10} x \quad x > 0
 \end{array}$$

Observe that some conditions, $x \neq 0$ and $x \geq 0$ and $x > 0$, are included for some of the expressions. Those conditions describe the domain of the function. For example, the domain of the function f defined by $F(x) = \log_{10} x$ is the set of positive numbers.

You may also see something like

$$\begin{aligned} F(x) &= \sqrt{1+x} & F(x) &= \frac{1-x}{1+x} \\ F(x) &= \sqrt{1-x^2} & F(x) &= \log_{10}(x^2-x) \end{aligned}$$

The intention is that the domain is the set of all values of x for which the expressions can be computed even though no restrictions are written. Often the restrictions are based on these rules:

1. Avoid dividing by zero.
2. Avoid computing the square root of negative numbers.
3. Avoid computing the logarithm of 0 and negative numbers.

Assuming we use only real numbers and not complex numbers, complete descriptions of the previous functions would be

$$\begin{aligned} f(x) &= \sqrt{1+x}, \quad x \geq -1 & F(x) &= \frac{1-x}{1+x}, \quad x \neq -1 \\ F(x) &= \sqrt{1-x^2}, \quad -1 \leq x \leq 1 & F(x) &= \log_{10}(x^2-x), \quad x < 0 \text{ or } 1 < x \end{aligned}$$

Use of parentheses. The use of parentheses in the function notation is special to functions and *does not mean multiplication*. The symbol inside the parentheses is always the independent variable, a member of the domain, and $F(x)$ is a value of the dependent variable, a member of the range. It is particularly tricky in that we will often need to use the symbol $F(x+h)$, and students confuse this with a multiplication and replace it with $F(x) + F(h)$. Seldom is this correct.

Example 2.3.1 For the function, R , defined by

$$R(x) = x + \frac{1}{x} \quad x \neq 0$$

$$R(1+3) = R(4) = 4 + \frac{1}{4} = 4.25$$

$$\begin{aligned} R(1) &= 1 + \frac{1}{1} = 2.0 & \text{and} \\ R(3) &= 3 + \frac{1}{3} = 3.3333 \dots \end{aligned}$$

$$R(1) + R(3) = 2 + 3.3333 \dots = 5.3333 \dots \neq 4.25 = R(4)$$

In this case

$$R(1+3) \neq R(1) + R(3) \quad \blacksquare$$

Exercises for Section 2.3 Function Notation.

Exercise 2.3.1 Let F be the collection of ordered number pairs to which an ordered pair (x, y) belongs if and only if x is a number and $y = x^2 + x$.

- a. Which of the ordered number pairs belong to F ? $(0,1)$, $(0,0)$, $(1,1)$, $(1,3)$, $(1,-1)$, $(-1,1)$, $(-1,0)$, $(-1,-1)$.
- b. Is there any uncertainty as to the members of F ?
- c. What is the domain of F ?
- d. What is the range of F ?

Exercise 2.3.2 For the function, F , defined by $F(x) = x^2$,

1. Compute $F(1 + 2)$, and $F(1) + F(2)$. Is $F(1 + 2) = F(1) + F(2)$?
2. Compute $F(3 + 5)$, and $F(3) + F(5)$. Is $F(3 + 5) = F(3) + F(5)$?
3. Compute $F(0 + 4)$, and $F(0) + F(4)$. Is $F(0 + 4) = F(0) + F(4)$?

Exercise 2.3.3 Find a function, L , defined for all numbers (domain is all numbers) such that for all numbers a and b , $L(a + b) = L(a) + L(b)$. Is there another such function?

Exercise 2.3.4 Find a function, M , defined for all numbers (domain is all numbers) such that for all numbers a and b , $M(a + b) = M(a) \times M(b)$. Is there another such function?

Exercise 2.3.5 For the function, $F(x) = x^2 + x$, compute the following

- | | |
|-----------------------------|-----------------------------|
| (a) $\frac{F(5)-F(3)}{5-3}$ | (b) $\frac{F(3+2)-F(3)}{2}$ |
| (c) $\frac{F(b)-F(a)}{b-a}$ | (d) $\frac{F(a+h)-F(a)}{h}$ |

Exercise 2.3.6 Repeat steps (a) - (d) of Exercise 2.3.5 for the functions

- | | |
|--------------------|----------------------|
| (i) $F(x) = 3x$ | (ii) $F(x) = x^3$ |
| (iii) $F(x) = 2^x$ | (iv) $F(x) = \sin x$ |

Exercise 2.3.7 a. In Figure 2.3.7A is the graph of $y^4 = x^2$ for $-2 \leq x \leq 2$. Write equations that define five different maximal simple subgraphs.

b. In Figure 2.3.7B is the graph of $|x| + |y| = 1$ for $-1 \leq x \leq 1$. Write equations that define five different maximal simple subgraphs.

Figure for Exercise 2.3.7 Graph of A $y^4 = x^2$, and B $|x| + |y| = 1$, for Exercise 2.3.7.

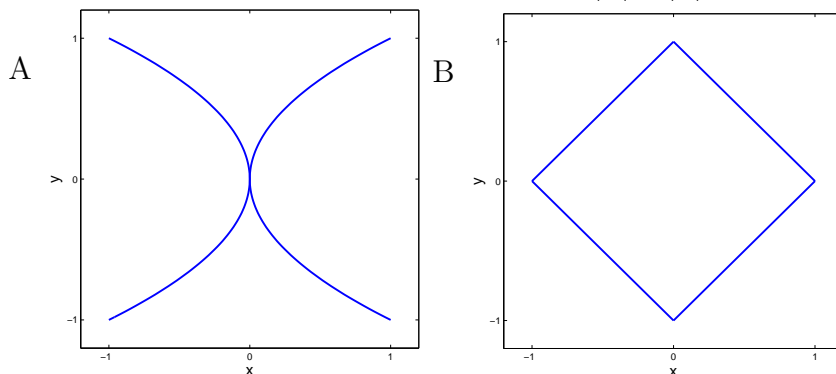

Exercise 2.3.8 What are the implied domains of the functions

$$\begin{aligned} F(x) &= \sqrt{x-1} & F(x) &= \frac{1+x^2}{1-x^2} \\ F(x) &= \sqrt{4-x^2} & F(x) &= \log_{10}(x^2) \end{aligned}$$

2.4 Polynomial functions.

Data from experiments (and their related functions) are often described as being linear, parabolic, hyperbolic, polynomial, harmonic (sines and cosines), exponential, or logarithmic either because their graphs have some resemblance to the corresponding geometric object or because equations describing their related functions use the corresponding expressions. In this section we extend linear and quadratic equations to more general polynomial functions.

Definition 2.4.1 Polynomial For n a positive integer or zero, a **polynomial of degree n** is a function, P defined by an equation of the form

$$P(x) = a_0 + a_1 x + a_2 x^2 + a_3 x^3 + \cdots + a_n x^n$$

where $a_0, a_1, a_2, a_3, \dots, a_n$ are numbers, independent of x , called the **coefficients of p** , and if $n > 0$ $a_n \neq 0$.

Functions of the form

$$P(x) = C \quad \text{where } C \text{ is a number}$$

are said to be constant functions and also polynomials of degree zero. Functions defined by equations

$$P(x) = a + bx \quad \text{and} \quad P(x) = a + bx + cx^2$$

are linear and quadratic polynomials, respectively, and are polynomials of degree one and degree two. The equation

$$P(x) = 3 + 5x + 2x^2 + (-4)x^3$$

is a polynomial of degree 3 with coefficients 3, 5, 2, and -4 and is said to be a cubic polynomial.

Polynomials are important for four reasons:

1. Polynomials can be computed using only the arithmetic operations of addition, subtraction, and multiplication.
2. Most functions used in science have polynomials “close” to them over finite intervals. See Figure 2.4, Example 2.5.2, and Exercise 2.5.3.
3. The sum of two polynomials is a polynomial, the product of two polynomials is a polynomial, and the composition of two polynomials is a polynomial.
4. Polynomials are ‘linear’ in their coefficients, a fact which makes them suitable for least squares ‘fit’ to data.

Reason 1 is obvious, but even the meaning of Reason 2 is opaque. An illustration of Reason 2 follows, and we return to the question in Chapter 12. Sum, product, and composition of two functions are described in Section 2.6. Reason 4 is illustrated in Example 2.4.1.

A tangent to a graph is a polynomial of degree one "close to" the graph. The graph of $F(x) = 2^x$ and the tangent

$$P_1(x) = 1 + 0.69315x \quad -1 \leq x \leq 2$$

at (0,1) are shown in Figure 2.4(a). The graph of the cubic polynomial

$$P_3(x) = 1 + 0.69315x + 0.24023x^2 + 0.055550x^3 \quad -1 \leq x \leq 2$$

shown in Figure 2.4(b) is even closer to the graph of $F(x) = 2^x$. These graphs are hardly distinguishable on $-1 \leq x \leq 1$ and only clearly separate at about $x = 1.5$. The function $F(x) = 2^x$ is difficult to evaluate (without a calculator) except at integer values of x , but $P_3(x)$ can be evaluated with just multiplication and addition. For $x = 0.5$, $F(0.5) = 2^{0.5} = \sqrt{2} = 1.41421$ and $P_3(0.5) = 1.41375$. The relative error in using $P_3(0.5)$ as an approximation to $\sqrt{2}$ is

$$\text{Relative Error} = \left| \frac{P_3(0.5) - F(0.5)}{F(0.5)} \right| = \left| \frac{1.41375 - 1.41421}{1.41421} \right| = 0.00033$$

The relative error is less than 0.04 percent.

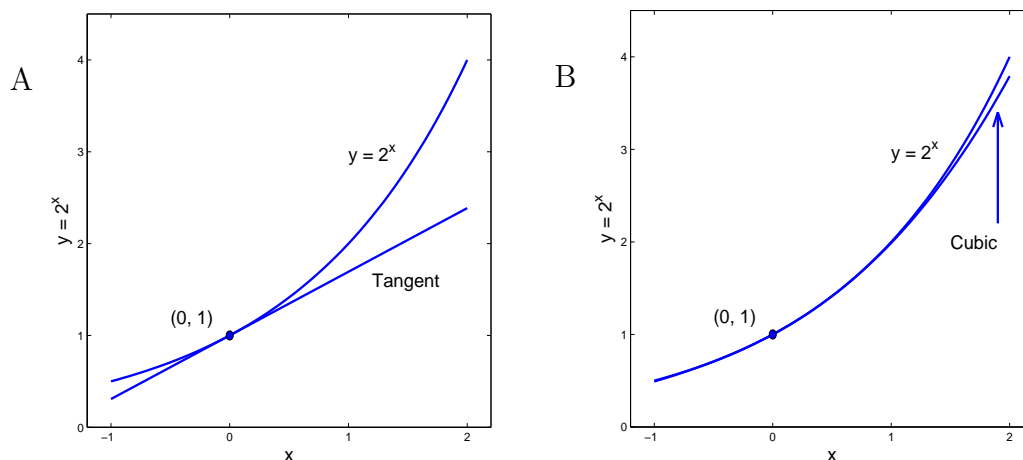

Figure 2.4: A. Graph of $y = 2^x$ and its tangent at (0,1), $P_1(x) = 1 + 0.69315x$. B. Graph of $y = 2^x$ and the cubic, $P_3(x) = 1 + 0.69315x + 0.24023x^2 + 0.055550x^3$.

The tangent $P_1(x)$ is a good approximation to $F(x) = 2^x$ near the point of tangency (0,1) and the cubic polynomial $P_3(x)$ is an even better approximation. The coefficients 0.69315, 0.24023, and 0.055550 are presented here as Lightning Bolts Out of the Blue. A well defined procedure for selecting the coefficients is defined in Chapter 12.

Explore 2.4.1 Find the relative error in using the tangent approximation, $P_1(0.5) = 1 + 0.69315 \times 0.5$ as an approximation to $F(0.5) = 2^{0.5}$. ■

Example 2.4.1 Problem. Show that polynomials are linear in their coefficients.
This means that

- The sum of two polynomials is obtained by adding 'corresponding' coefficients (add the constant terms, add the coefficients of x , add the coefficients of x^2 , \dots).
- The product of a constant, K , and a polynomial, $P(x)$, is the polynomial whose coefficients are the coefficients of $P(x)$ each multiplied by K .

Consider the following.

$$\text{Let } P(x) = 7 - 3x + 5x^2, \quad \text{and} \quad Q(x) = -2 + 4x - x^2 + 6x^3.$$

$$\begin{aligned} P(x) + Q(x) &= (7 - 3x + 5x^2) + (-2 + 4x - x^2 + 6x^3) \\ &= (7 - 2) + (-3 + 4)x + (5 - 1)x^2 + (0 + 6)x^3 \\ &= 5 + x + 4x^2 + 6x^3 \end{aligned}$$

Thus $P(x) + Q(x)$ is simply the polynomial obtained by adding corresponding coefficients in $P(x)$ and $Q(x)$. Furthermore,

$$13 \cdot P(x) = 13(7 - 3x + 5x^2) = 13 \cdot 7 - 13 \cdot 3x + 13 \cdot 5x^2 = 91 - 39x + 65x^2.$$

Thus $13 \cdot P(x)$ is simply the polynomial obtained by multiplying each coefficient of $P(x)$ by 13.

On the other hand, for

$$P(x) = 5 \sin 3x, \quad Q(x) = 6 \sin 4x,$$

$$P(x) + Q(x) = 5 \sin 3x + 6 \sin 4x \neq (5 + 6) \sin((3 + 4)x) = 11 \sin 7x.$$

The sine functions are not linear in their coefficients.

Exercises for Section 2.4 Polynomial functions.

Exercise 2.4.1 Technology. Let $F(x) = \sqrt{x}$. The polynomials

$$P_2(x) = \frac{3}{4} + \frac{3}{8}x - \frac{1}{64}x^2 \quad \text{and} \quad P_3(x) = \frac{5}{8} + \frac{15}{32}x - \frac{5}{128}x^2 + \frac{1}{512}x^3$$

closely approximate F near the point $(4,2)$ of F .

- Draw the graphs of F and P_2 on the range $1 \leq x \leq 8$.
- Compute the relative error in $P_2(2)$ as an approximation to $F(2) = \sqrt{2}$.
- Draw the graphs of F and $P_3(x)$ on the range $1 \leq x \leq 8$.
- Compute the relative error in $P_3(2)$ as an approximation to $F(2) = \sqrt{2}$.

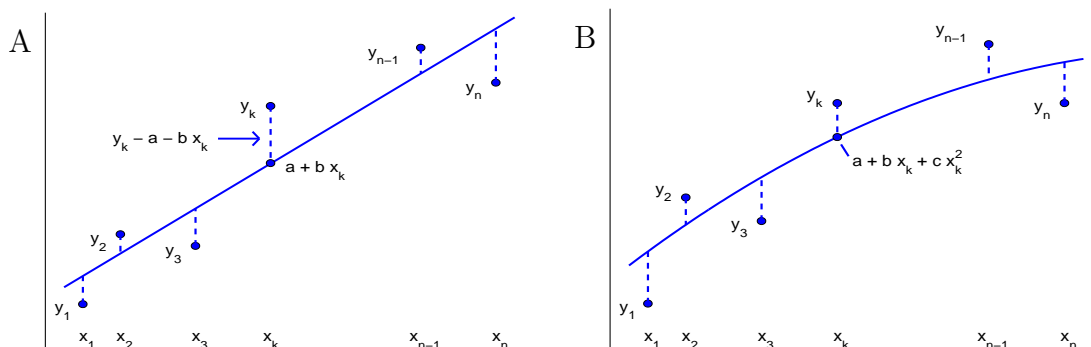

Figure 2.5: A. Least squares fit of a line to data. B. Least squares fit of a parabola to data.

Exercise 2.4.2 Technology. Let $F(x) = \sqrt[3]{x}$. The polynomials

$$P_2(x) = \frac{5}{9} + \frac{5}{9}x - \frac{1}{9}x^2 \quad \text{and} \quad P_3(x) = P_2(x) + \frac{5}{81}(x-1)^3$$

closely approximate F near the point $(1,1)$ of F .

- Draw the graphs of F and P_2 on the range $0 \leq x \leq 3$.
- Compute the relative error in $P_2(2)$ as an approximation to $F(2) = \sqrt[3]{2}$.
- Draw the graphs of F and P_3 on the range $1 \leq x \leq 3$.
- Compute the relative error in $P_3(2)$ as an approximation to $F(2) = \sqrt[3]{2}$.

2.5 Least squares fit of polynomials to data

Polynomials and especially linear functions are often 'fit' to data as a means of obtaining a brief and concise description of the data. The most common and widely used method is the method of *least squares*. To fit a line to a data set, $(x_1, y_1), (x_2, y_2), \dots, (x_n, y_n)$, one selects a and b that minimizes

$$\sum_{k=1}^n (y_k - a - b x_k)^2 \tag{2.2}$$

The geometry of this equation is illustrated in Figure 2.5. The goal is to select a and b so that the sum of the squares of the lengths of the dashed lines is as small as possible.

We show in Example 13.2.2 that the optimum values of a and b satisfy

$$\begin{aligned} an + b \sum_{k=1}^n x_k &= \sum_{k=1}^n y_k \\ a \sum_{k=1}^n x_k + b \sum_{k=1}^n x_k^2 &= \sum_{k=1}^n x_k y_k \end{aligned} \tag{2.3}$$

Table 2.2: Relation between temperature and frequency of cricket chirps.

Temperature °F										
Chirps per										
Minute	109	136	160	87	103	102	108	154	144	150

The solution to these equations is

$$\begin{aligned}
 a &= \frac{\sum_{k=1}^n x_k^2 \sum_{k=1}^n y_k - \left(\sum_{k=1}^n x_k\right) \left(\sum_{k=1}^n x_k y_k\right)}{\Delta} \\
 b &= \frac{n \sum_{k=1}^n x_k y_k - \left(\sum_{k=1}^n x_k\right) \left(\sum_{k=1}^n y_k\right)}{\Delta} \\
 \Delta &= n \sum_{k=1}^n x_k^2 - \left(\sum_{k=1}^n x_k\right)^2
 \end{aligned} \tag{2.4}$$

Example 2.5.1 If we use these equations to fit a line to the cricket data of Example 1.10.1 showing a relation between temperature and cricket chirp frequency, we get

$$y = 4.5008x - 192.008, \quad \text{close to the line} \quad y = 4.5x - 192$$

that we 'fit by eye' using the two points, (65,100) and (75,145).



Explore 2.5.1 Technology. Your calculator or computer will hide all of the arithmetic of Equations 2.4 and give you the answer. The overall procedure is:

1. Load the data. [Two lists, X and Y, say].
2. Compute the coefficients of a first degree polynomial close to the data and store them in P.
3. Specify X coordinates and compute corresponding Y coordinates for the polynomial.
4. Plot the original data and the computed polynomial.

A MATLAB program to do this is:

```

close all;clc;clear
X=[67 73 78 61 66 66 67 77 74 76];
Y=[109 136 160 87 103 102 108 154 144 150];
P=polyfit(X,Y,1)
PX=[60:0.1:80];
PY=polyval(P,PX);
plot(X,Y,'+', 'linewidth',2); hold('on'); plot(PX,PY,'linewidth',2)
    
```



Table 2.3: A tube is filled with water and a hole is opened at the bottom of the tube. Relation between height of water remaining in the tube and time.

Time sec	0	5	10	15	20	25	30	35	40	45	50	55	60
Height cm	85	73	63	54	45	36	29	22	17	12	7	4	2

To fit a parabola to a data set, $(x_1, y_1), (x_2, y_2), \dots, (x_n, y_n)$, one selects a, b and c that minimizes

$$\sum_{k=1}^n (y_k - a - b x_k - c x_k^2)^2 \quad (2.5)$$

The geometry of this equation is illustrated in Figure 2.5B. The goal is to select a, b and c so that the sum of the squares of the lengths of the dashed lines is as small as possible.

The optimum values of a, b , and c satisfy (Exercise 14.2.4)

$$\begin{aligned} a n + b \sum x_k + c \sum x_k^2 &= \sum y_k \\ a \sum x_k + b \sum x_k^2 + c \sum x_k^3 &= \sum x_k y_k \\ a \sum x_k^2 + b \sum x_k^3 + c \sum x_k^4 &= \sum x_k^2 y_k \end{aligned} \quad (2.6)$$

There is a methodical procedure for solving three linear equations three variables using pencil and paper. For now it is best to rely on your calculator or computer.

Explore 2.5.2 Technology. Fit a parabola to the water draining from a tube data of Figure 1.25 reproduced in Table 2.3.

The procedure will be almost identical to that of Explore 2.5.1. The difference is that in step 2 you will compute the coefficients of a *second* degree polynomial. The line `P=polyfit(X,Y,1)` will be changed to `P=polyfit(X,Y,2)`. In the program, of course, the data will be different and the PX-values for the polynomial will be adjusted to the data. ■

Example 2.5.2 A graph of the polio data from Example 2.2.1 showing the percent of U.S. population that had antibodies to the polio virus in 1955 is shown in Figure 2.6. Also shown is a graph of the fourth degree polynomial

$$P_4(x) = -4.13 + 7.57x - 0.136x^2 - 0.00621x^3 + 0.000201x^4$$

The polynomial that ‘fit’ the polio data using a MATLAB program similar to that described in Explore 2.5.1 and discussed in Explore 2.5.2 The technology selects the coefficients, $-4.14, 7.57, \dots$ so that the sum of the squares of the distances from the polynomial to the data is as small as possible. ■

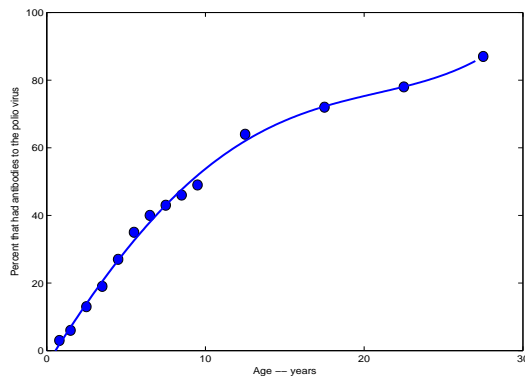

Figure 2.6: A fourth-degree polynomial fit to data for percent of people in 1955 who had antibodies to the polio virus as a function of age. Data read from Anderson and May, Vaccination and herd immunity to infectious diseases, *Nature* **318** 1985, pp 323-9, Figure 2f.

Exercises for Section 2.5, Least squares fit of polynomials to data.

Exercise 2.5.1 Use Equations 2.3 to find the linear function that is the least squares fit to the data:

$$(-2, 5) \quad (3, 12)$$

Exercise 2.5.2 Use Equations 2.6 to find the quadratic function that is the least squares fit to the data:

$$(-2, 5) \quad (3, 12) \quad (10, 0)$$

Exercise 2.5.3 Technology Shown in the Table 2.4 are the densities of water at temperatures from 0 to 100 °C Use your calculator or computer to fit a cubic polynomial to the data. See Explore 2.5.1 and Explore 2.5.2. Compare the graphs of the data and of the cubic.

Table 2.4: The density of water at various temperatures Source: Robert C. Weast, Melvin J. Astle, and William H. Beyer, *CRC Handbook of Chemistry and Physics*, 68th Edition, 1988, CRC Press, Boca Raton, FL, p F-10.

Temp °C	Density g/cm ³	Temp °C	Density g/cm ³
0	0.99987	45	0.99025
3.98	1.00000	50	0.98807
5	0.99999	55	0.98573
10	0.99973	60	0.98324
15	0.99913	65	0.98059
18	0.99862	70	0.97781
20	0.99823	75	0.97489
25	0.99707	80	0.97183
30	0.99567	85	0.96865
35	0.99406	90	0.96534
38	0.99299	95	0.96192
40	0.99224	100	0.95838

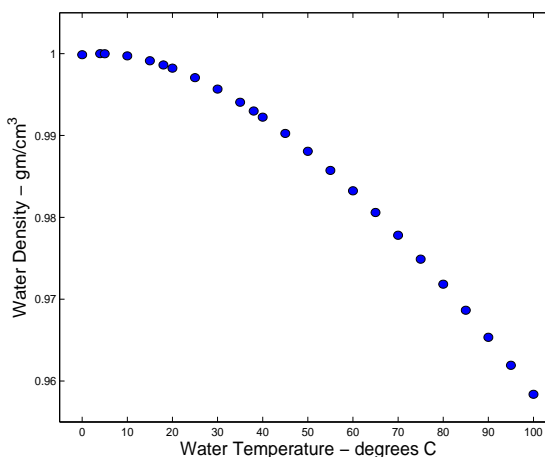

Exercise 2.5.3. $D(T) = 1.00004105 + 0.00001627T - 0.000005850T^2 + 0.000000015324T^3$.

2.6 New functions from old.

It is often important to recognize that a function of interest is made up of component parts — other functions that are combined to make up the function of central interest. Researchers monitoring natural populations (deer, for example) partition the dynamics into the algebraic *sum* of births, deaths, and harvest. Researchers monitoring annual grain production in the United States decompose the production into the *product* of the number of acres planted and yield per acre.

$$\text{Total Corn Production} = \text{Acres Planted to Corn} \times \text{Yield per Acre}$$

$$P(t) = A(t) \times Y(t)$$

Factors that influence $A(t)$, the number of acres planted (government programs, projected corn price, alternate cropping opportunities, for example) are qualitatively different from the factors that influence $Y(t)$, yield per acre (corn genetics, tillage practices, and weather).

2.6.1 Arithmetic combinations of functions.

A common mathematical strategy is “divide and conquer” — partition your problem into smaller problems, each of which you can solve. Accordingly it is helpful to recognize that a function is composed of component parts. Recognizing that a function is the sum, difference, product, or quotient of two functions is relatively simple.

Definition 2.6.1 Arithmetic Combinations of Functions. *If F and G are two functions with common domain, D , The sum, difference, product, and quotient of F and G are functions, $F+G$, $F-G$, $F \times G$, and $F \div G$, respectively defined by*

$$(F + G)(x) = F(x) + G(x) \quad \text{for all } x \text{ in } D$$

$$(F - G)(x) = F(x) - G(x) \quad \text{for all } x \text{ in } D$$

$$(F \times G)(x) = F(x) \times G(x) \quad \text{for all } x \text{ in } D$$

$$(F \div G)(x) = F(x) \div G(x) \quad \text{for all } x \text{ in } D \text{ with } G(x) \neq 0$$

For example $F(t) = 2^t + t^2$ is the sum of an exponential function, $E(t) = 2^t$ and a quadratic function, $S(t) = t^2$. Which of the two functions dominates (contributes most to the value of F) for $t < 0$? For $t > 0$ (careful here, the graphs are incomplete). Shown in Figure 2.7 are the graphs of E and S .

Next in Figure 2.8 are the graphs of

$$E + S, \quad E - S, \quad E \times S, \quad \text{and} \quad \frac{E}{S}$$

but not necessarily in that order. Which graph depicts which of the combinations of S and E ?

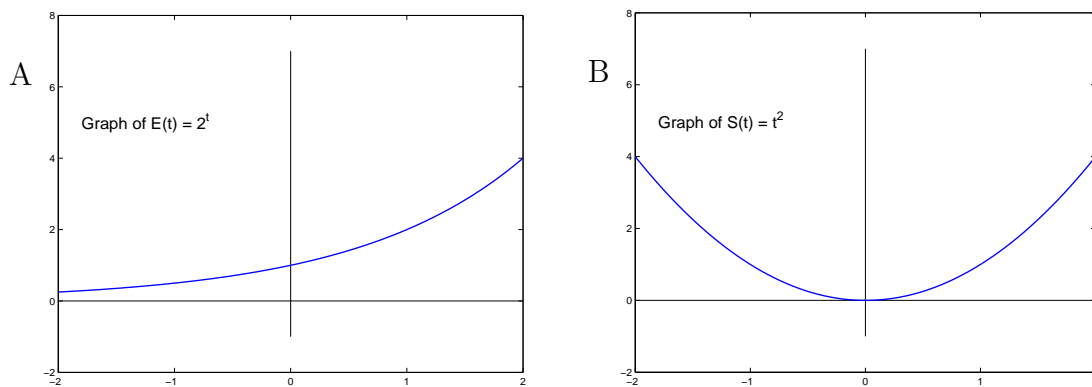

Figure 2.7: Graphs of A. $E(t) = 2^t$ and B. $S(t) = t^2$.

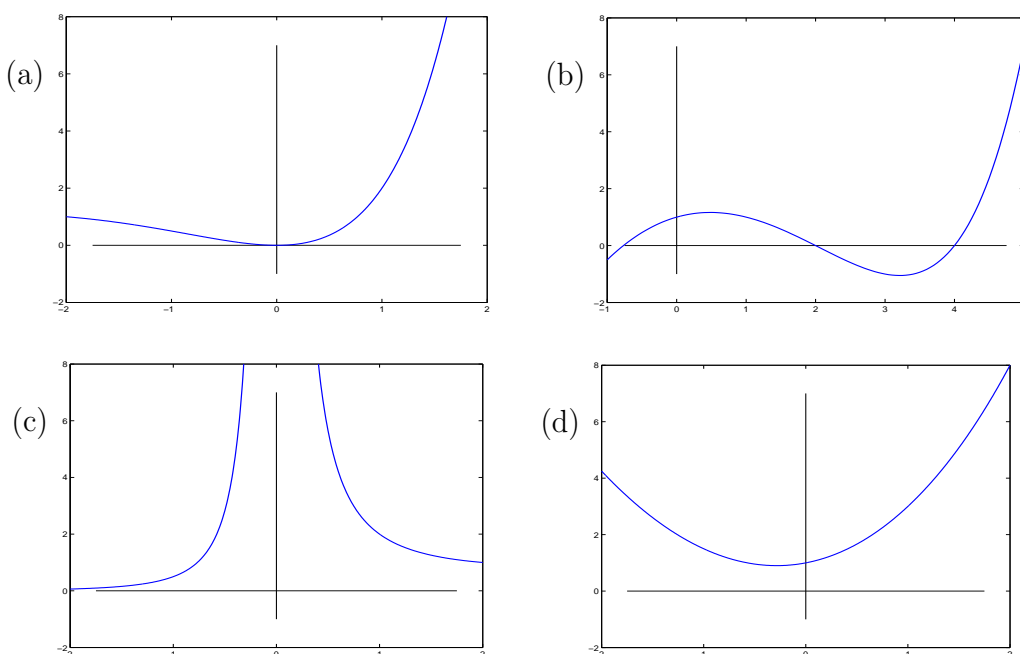

Figure 2.8: Graphs of the sum, difference, product, and quotient of $E(t) = 2^t$ and $S(t) = t^2$.

Note first that the domains of E and S are all numbers, so that the domains of $E + S$, $E - S$, and $E \times S$ are also all numbers. However, the domain of E/S excludes 0 because $S(0) = 0$ and $E(0)/S(0) = 1/0$ is meaningless.

The graph in Figure 2.8(c) appears to not have a point on the y -axis, and that is a good candidate for E/S . $E(t)$ and $S(t)$ are never negative, and the sum, product, and quotient of non-negative numbers are all non-negative. However, the graph in Figure 2.8(b) has some points below the x -axis, and that is a good candidate for $E - S$.

The product, $E \times S$ is interesting for $t < 0$. The graph of $E = 2^t$ is asymptotic to the negative t -axis; as t progresses from -1 to -2 to -3 to \dots , $E(t)$ is $2^{-1} = 0.5$, $2^{-2} = 0.25$, $2^{-3} = 0.125$, \dots and gets close to zero. But $S(t) = t^2$ is $(-1)^2 = 1$, $(-2)^2 = 3$, $(-3)^2 = 9$, \dots gets very large. What does the product do?

2.6.2 The inverse of a function.

Suppose you have a travel itinerary as shown in Table 2.5. If your traveling companion asks,

Table 2.5: Itinerary for (brief) European trip.

Day	June 1	June 2	June 3	June 4	June 5	June 6	June 7
City	London	London	London	Brussels	Paris	Paris	Paris

“What day were we in Brussels?”, you may read the itinerary ‘backward’ and respond that you were in Brussels on June 4. On the other hand, if your companion asks, “I cashed a check in Paris, what day was it?”, you may have difficulty in giving an answer.

An itinerary is a function that specifies that on day, x , you will be in location, y . You have inverted the itinerary and reasoned that for the city Brussels, the day was June 4. Because you were in Paris June 5 - 7, you can not specify the day that the check was cashed.

Charles Darwin exercised an inverse in an astounding way. In his book, *On the Various Contrivances by which British and Foreign Orchids are Fertilised by Insects* he stated that the angraecoids were pollinated by specific insects. He noted that *A. sesquipedale* in Madagascar had nectaries eleven and a half inches long with only the lower one and one-half inch filled with nectar. He suggested the existence of a ‘huge moth, with a wonderfully long proboscis’ and noted that if the moth ‘were to become extinct in Madagascar, assuredly the *Angraecum* would become extinct.’ Forty one years later *Xanthopan morgani praedicta* was found in tropical Africa with a proboscis of ten inches.

Such inverted reasoning occurs often.

Explore 2.6.1 Answer each of the following by examining the inverse of the function described.

- Rate of heart beat increases with level of exertion; heart is beating at 165 beats per minute; is the level of exertion high or low? You may want to visit en.wikipedia.org/wiki/Heart_rate.
- Resting blood pressure goes up with artery blockage; resting blood pressure is 110 (systolic) ‘over’ 70 (diastolic); is the level of artery blockage high or low? The answer can be found in en.wikipedia.org/wiki/Blood_Pressure.
- Diseases have symptoms; a child is observed with a rash over her body. Is the disease chicken pox?

■

The child with a rash in Example c. illustrates again an ambiguity often encountered with inversion of a function; the child may in fact have measles and not chicken pox. The inverse information may be multivalued and therefore not a function. Nevertheless, the doctor may make a diagnosis as the most probable disease, given the observed symptoms. She may be influenced by facts such as

- Blood analysis has demonstrated that five other children in her clinic have had chicken pox that week and,
- Because of measles immunization, measles is very rare.

It may be that she can actually distinguish chicken pox rash from measles rash, in which case the ambiguity disappears.

The definition of the inverse of a function is most easily made in terms of the ordered pair definition of a function. Recall that a function is a collection of ordered number pairs, no two of which have the same first term.

Definition 2.6.2 Inverse of a Function. *A function F is invertible if no two ordered pairs of F have the same second number. The inverse of an invertible function, F , is the function G to which the ordered pair (x,y) belongs if and only if (y,x) is an ordered pair of F . The function, G , is often denoted by F^{-1} .*

Explore 2.6.2 Do This. Suppose G is the inverse of an invertible function F . What is the inverse of G ? ■

Table 2.6: Of the two itineraries shown below, the one on the left is invertible.

Day	Location	Day	Location	Day	Location	Day	Location
June 4	London	June 8	Vienna	June 4	London	June 8	Zurich
June 5	Amsterdam	June 9	Zurich	June 5	Paris	June 9	Zurich
June 6	Paris	June 10	Venice	June 6	Paris	June 10	Rome
June 7	Berlin	June 11	Rome	June 7	Paris	June 11	Rome

The notation F^{-1} for the inverse of a function F is distinct from the use of $^{-1}$ as an exponent meaning division, as in $2^{-1} = \frac{1}{2}$. In this context, F^{-1} does not mean $\frac{1}{F}$, even though students have good reason to think so from previous use of the symbol, $^{-1}$. The TI-86 calculator (and others) have keys marked \sin^{-1} and x^{-1} . In the first case, the $^{-1}$ signals the inverse function, $\arcsin x$, in the second case the $^{-1}$ signals reciprocal, $1/x$. Given our desire for uniqueness of definition and notation, the ambiguity is unfortunate and a bit ironic. There is some recovery, however. You will see later that the composition of functions has an algebra somewhat like ‘multiplication’ and that ‘multiplying’ by an inverse of a function F has some similarity to ‘dividing’ by F . At this stage, however, the only advice we have is to interpret h^{-1} as ‘divide by h ’ if h is a number and as ‘inverse of h ’ if h is a function or a graph.

The graph of a function easily reveals whether it is invertible. Remember that the graph of a function is a *simple graph*, meaning that no vertical line contains two points of the graph.

Definition 2.6.3 Invertible graph. *An invertible simple graph is a simple graph for which no horizontal line contains two points. A simple graph is invertible if and only if it is the graph of an invertible function.*

The simple graph G in Figure 2.9(a) has two points on the same horizontal line. The points have the same y -coordinate, y_1 , and thus the function defining G has two ordered pairs, (x_1, y_1) and (x_2, y_1) with the same second term. The function is not invertible. The same simple graph G does contain a simple graph that is invertible, as shown as the solid curve in Figure 2.9(b), and it is maximal in the sense that if any additional point of the graph of G is added to it, the resulting graph is not invertible.

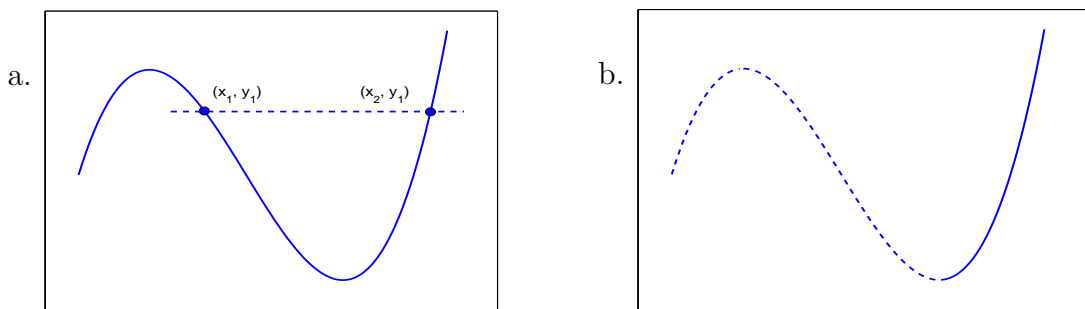

Figure 2.9: Graph of a function that is not invertible.

Explore 2.6.3 Find another simple graph contained in the graph G of Figure 2.9(a) that is invertible. Is your graph maximal? Is there a simple graph contained in G other than that shown in Figure 2.9 that is invertible and maximal? ■

Example 2.6.1 Shown in Figure 2.10 is the graph of an invertible function, F , as a solid line and the graph of F^{-1} as a dashed line. Tables of seven ordered pairs of F and seven ordered pairs of F^{-1} are given. Corresponding to the point, $P(3.0, 1.4)$ of F is the point, $Q(1.4, 3.0)$ of F^{-1} . The line $y = x$ is the perpendicular bisector of the interval, \overline{PQ} . Observe that the domain of F^{-1} is the range of F , and the range of F^{-1} is the domain of F . ■ ■

The preceding example lends support for the following observation.

The graph of the inverse of F is the reflection of the graph of F about the diagonal line, $y = x$.

The reflection of G with respect to the diagonal line, $y = x$ consists of the points Q such that either Q is a point of G on the diagonal line, or there is a point P of G such that the diagonal line is the perpendicular bisector of the interval \overline{PQ} .

The concept of the inverse of a function makes it easier to understand logarithms. Shown in Table 2.7 are some ordered pairs of the exponential function, $F(x) = 10^x$ and some ordered pairs of the logarithm function $G(x) = \log_{10}(x)$. The logarithm function is simply the inverse of the exponential function.

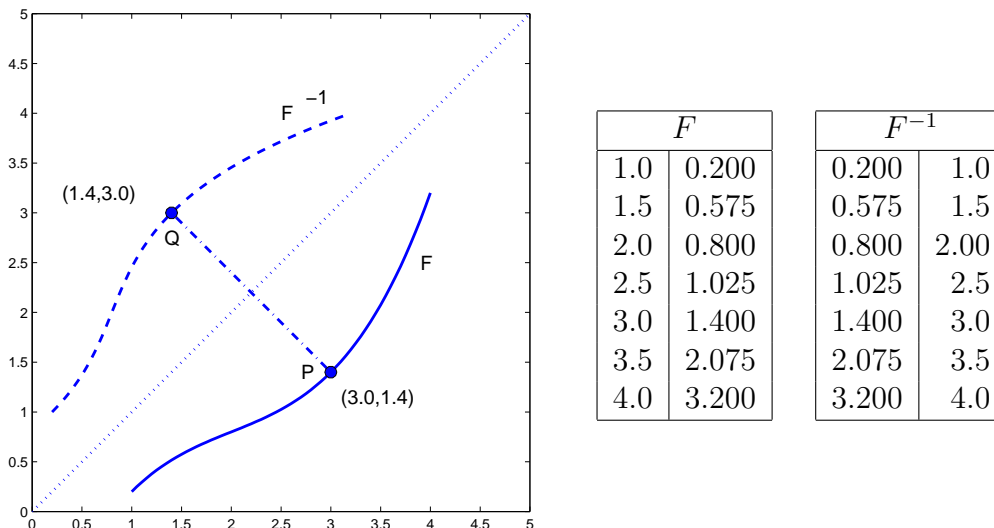

Figure 2.10: Graph of a function F (solid line) and its inverse F^{-1} (dashed line) and tables of data for F and F^{-1} .

Table 2.7: Partial data for the function $F(x) = 10^x$ and its inverse $G(x) = \log_{10}(x)$.

x	10^x
-2	0.01
-1	0.1
0	1
1	10
2	100
3	1000

x	$\log_{10} x$
0.01	-2
0.1	-1
1	0
10	1
100	2
1000	3

The function $F(x) = x^2$ is not invertible. In Figure 2.11 both $(-2,4)$ and $(2,4)$ are points of the graph of F so that the horizontal line $y = 4$ contains two points of the graph of F . However, the function S defined by

$$S(x) = x^2 \quad \text{for } x \geq 0 \tag{2.7}$$

is invertible and its inverse is

$$S^{-1}(x) = \sqrt{x}.$$

2.6.3 Finding the equation of the inverse of a function.

There is a straightforward means of computing the equation of the inverse of a function from the equation of the function. The inverse function reverses the role of the independent and dependent variables. The independent variable for the function is the dependent variable for the inverse function. To compute the equation for the inverse function, it is common to interchange the symbols for the dependent and independent variables.

Example 2.6.2 To compute the equation for the inverse of the function S ,

$$S(x) = x^2 \quad \text{for } x \geq 0$$

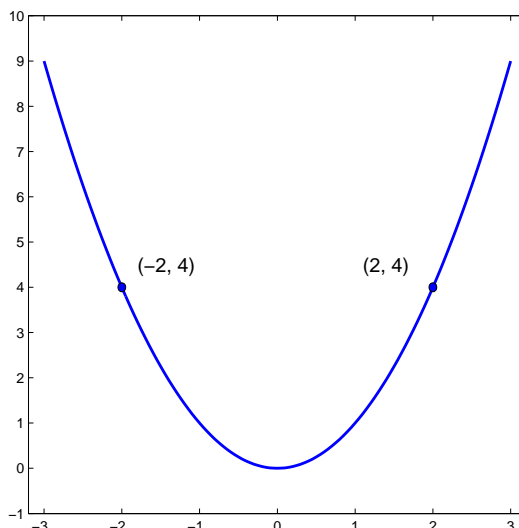

Figure 2.11: Graph of $F(x) = x^2$; $(-2,4)$ and $(2,4)$ are both points of the graph indicating that F is not invertible.

let the equation for S be written as

$$y = x^2 \quad \text{for} \quad x \geq 0$$

Then interchange y and x to obtain

$$x = y^2 \quad \text{for} \quad y \geq 0$$

and solve for y .

$$\begin{aligned} x &= y^2 & \text{for} & \quad y \geq 0 \\ y^2 &= x & \text{for} & \quad y \geq 0 \\ (y^2)^{\frac{1}{2}} &= x^{\frac{1}{2}} \\ y^{2 \cdot \frac{1}{2}} &= x^{\frac{1}{2}} \\ y &= x^{\frac{1}{2}} \end{aligned}$$

Therefore

$$S^{-1}(x) = \sqrt{x} \quad \text{for} \quad x \geq 0 \quad \blacksquare$$

■

Example 2.6.3 The graph of function $F(x) = 2x^2 - 6x + 3/2$ shown in Figure 2.12 has two invertible portions, the left branch and the right branch. We compute the inverse of each of them.

Let $y = 2x^2 - 6x + 5/2$, exchange symbols $x = 2y^2 - 6y + 5/2$, and solve for y . We use the

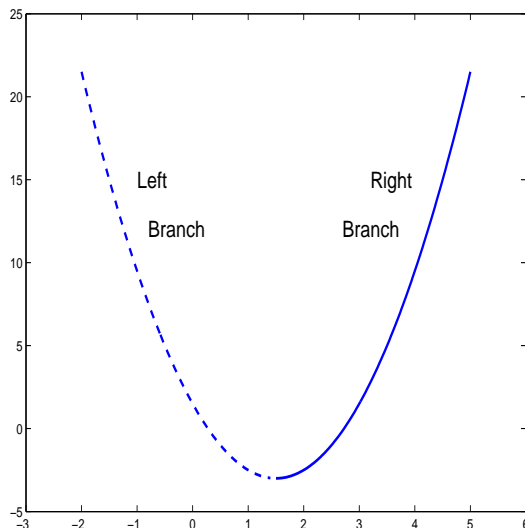

Figure 2.12: Graph of $F(x) = 2x^2 - 6x + 3/2$ showing the left branch as dashed line and right branch as solid line.

steps of ‘completing the square’ that are used to obtain the quadratic formula.

$$\begin{aligned}
 x &= 2y^2 - 6y + 5/2 \\
 &= 2(y^2 - 3y + 9/4) - 9/2 + 5/2 \\
 &= 2(y - 3/2)^2 - 2 \\
 (y - 3/2)^2 &= \frac{x + 2}{2} \\
 y - 3/2 &= \sqrt{\frac{x + 2}{2}} \quad \text{or} \quad -\sqrt{\frac{x + 2}{2}} \\
 y &= \frac{3}{2} + \sqrt{\frac{x + 2}{2}} && \text{Right branch inverse.} \\
 y &= \frac{3}{2} - \sqrt{\frac{x + 2}{2}} && \text{Left branch inverse.}
 \end{aligned}$$

■

Exercises for Section 2.6 New functions from old.

Exercise 2.6.1 In Figure 2.8 identify the graphs of $E + S$ and $E \times S$.

Exercise 2.6.2 Three examples of biological functions and questions of inverse are described in Explore 2.6.1. Identify two more functions and related inverse questions.

Exercise 2.6.3 The genetic code appears in Figure 2.3. It occasionally occurs that the amino acid sequence of a protein is known, and one wishes to know the DNA sequence that coded for it. That the genetic code is not invertible is illustrated by the following problem.

Find two DNA sequences that code for the amino acid sequence KYLEF. (Note: K = Lys = lysine, Y = Tyr = tyrosine, L = Leu = leucine, E = Glu = glutamic acid, F = Phe = phenylalanine. The sequence KYLEF occurs in sperm whale myoglobin.)

Exercise 2.6.4 Which of the following functions are invertible?

- The distance a DNA molecule will migrate during agarose gel electrophoresis as a function of the molecular weight of the molecule, for domain: $1\text{kb} \leq \text{Number of bases} \leq 20\text{kb}$.
- The density of water as a function of temperature.
- Day length as a function of elevation of the sun above the horizon (at, say, 40 degrees North latitude).
- Day length as a function of day of the year.

Exercise 2.6.5 Shown in Figure Ex. 2.6.5 is the graph of a function, F . Some ordered pairs of the function are listed in the table and plotted as filled circles. What are the corresponding ordered pairs of F^{-1} ? Plot those points and draw the graph of F^{-1} .

Figure for Exercise 2.6.5 Partial data and a graph of an invertible function, F , and the diagonal, $y = x$. See Exercise 2.6.5.

x	$F(x)$
0	0
1	0.2
2	0.8
3	1.8
4	3.2
5	1.0
6	7.2

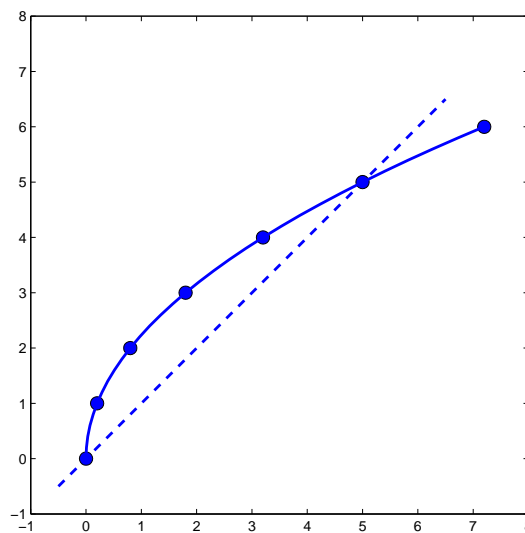

Exercise 2.6.6 Shown in Figure Ex. 2.6.6 is the graph of $F(x) = 2^x$. $(-2, 1/4)$, $(0, 1)$, and $(2, 4)$ are ordered pairs of F . What are the corresponding ordered pairs of F^{-1} ? Plot those points and draw the graph of F^{-1} .

Figure for Exercise 2.6.6 Graph of $F(x) = 2^x$ and the diagonal, $y = x$. See Exercise 2.6.6

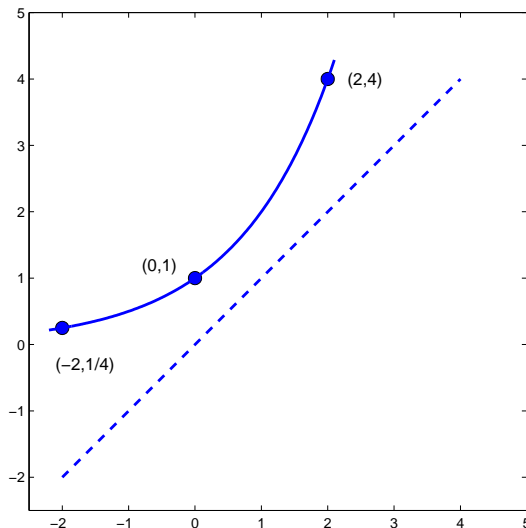

Exercise 2.6.7 In Subsection 2.2.2 Simple Graphs and Figure 2.2 it is observed that the circle is not a simple graph but contained several simple graphs that were ‘as large as possible’, meaning that if another point of the circle were added to them they would not be simple graphs. Neither of the examples in Figure 2.2 is invertible. Does the circle contain a simple graph that is as large as possible and that is an invertible simple graph?

Exercise 2.6.8 Shown in Figure Ex. 2.6.8 is a graph of a function, F . Make a table of F and F^{-1} and plot the points of the inverse. Let G be F^{-1} . Make a table of G^{-1} and plot the points of G^{-1} .

Figure for Exercise 2.6.8 Graph of a function F . See Exercise 2.6.8.

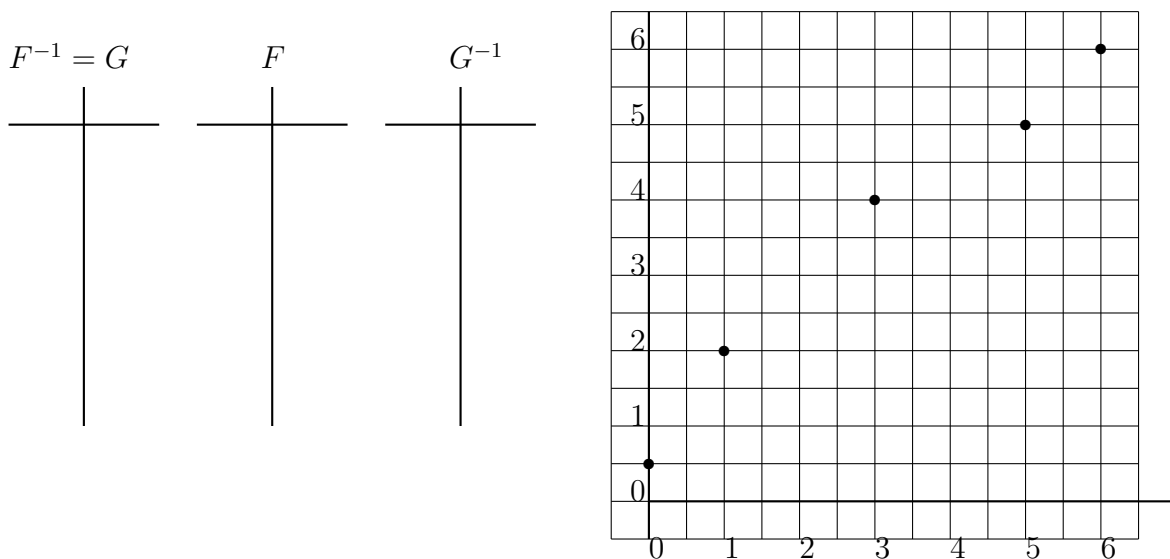

Exercise 2.6.9 Is there an invertible function whose domain is the set of positive numbers and whose range is the set of non-negative numbers?

Exercise 2.6.10 Incredible! Find the inverse of the function, F , defined by

$$F(x) = x^{-1}$$

Hint: Look at its graph.

Exercise 2.6.11 Answer the question in Explore 2.6.2, Suppose G is the inverse of an invertible function F . What is the inverse of G ?

Exercise 2.6.12 Find equations for the inverses of the functions defined by

$$\begin{array}{ll} \text{(a)} & F_1(x) = \frac{1}{x+1} \\ \text{(b)} & F_2(x) = \frac{x}{x+1} \\ \text{(c)} & F_3(x) = 1 + 2^x \\ \text{(d)} & F_4(x) = \log_2 x - \log_2(x+1) \\ \text{(e)} & F_5(x) = 10^{-x^2} \text{ for } x \geq 0 \\ \text{(f)} & F_6(z) = \frac{z+\frac{1}{z}}{2} \text{ for } z \geq 1 \\ \text{(g)} & F_7(x) = \frac{2^x - 2^{-x}}{2} \end{array}$$

Hint for (g): Let $y = \frac{2^x - 2^{-x}}{2}$, interchange x and y so that $x = \frac{2^y - 2^{-y}}{2}$, then substitute $z = 2^y$ and solve for z in terms of x . Then insert $2^y = z$ and solve for y .

Exercise 2.6.13 Mutations in mitochondrial DNA occur at the rate of 15 per 10^2 base pairs per million years. Therefore, the number of differences, D , expected between two present mitochondrial DNA sequences of length L would be

$$D = 2 \frac{15}{100} L \frac{T}{1000000} \quad (2.8)$$

where T is number of years since the most recent ancestor of the mitochondrial sequences.

1. Explain the factor of 2 in Equation 2.8. (Hint: consider the phylogenetic tree shown in Figure Ex. 2.6.13)
2. The African pygmy and the Papua-New Guinea aborigine mitochondrial DNA differ by 2.9%. How many years ago did their ancestral populations diverge?

Figure for Exercise 2.6.13 Phylogenetic tree showing divergence from an ancestor.

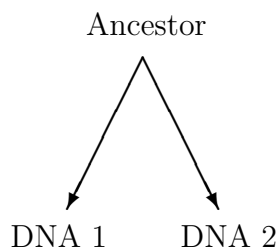

2.7 Composition of functions

Another important combination of functions is illustrated by the following examples. The general picture is that A depends on B , B depends on C , so that A depends on C .

1. **The coyote population is affected by a rabbit virus, *Myxomatosis cuniculi*.** The size of a coyote population depends on the number of rabbits in the system; the rabbits are affected by the virus *Myxomatosis cuniculi*; the size of the coyote population is a function of the prevalence of *Myxomatosis cuniculi* in rabbits.
2. **Heart attack incidence is decreased by low fat diets.** Heart attacks are initiated by atherosclerosis, a buildup of deposits in the arteries; in people with certain genetic makeups³, the deposits are decreased with a low fat diet. The risk of heart attacks in some individuals is decreased by low fat diets.
3. **You shiver in a cold environment.** You step into a cold environment and cold receptors (temperature sensitive nerves with peak response at 30°C) send signals to your hypothalamus; the hypothalamus causes signals to be sent to muscles, increasing their tone; once the tone reaches a threshold, rhythmic muscle contractions begin. See Figure 2.13.
4. **Severity of allergenic diseases is increasing.** Childhood respiratory infections such as measles, whooping cough, and tuberculosis stimulate a helper T-cell, T_H1 activity. Increased T_H1 activity inhibits T_H2 (another helper T-cell) activity. Absence of childhood respiratory diseases thus releases T_H2 activity. But T_H2 activity increases immunoglobulin E which is a component of allergenic diseases of asthma, hay fever, and eczema. Thus reducing childhood respiratory infections may partially account for the observed recent increase in severity of allergenic diseases⁴.

Definition 2.7.1 Composition of Functions. *If F and G are two functions and the domain of F contains part of the range of G , then the composition of F with G is the function, H , defined by*

$$H(x) = F(G(x)) \quad \text{for all } x \text{ for which } G(x) \text{ is in the domain of } F$$

The composition, H , is denoted by $F \circ G$.

The notation $F \circ G$ for the composition of F with G means that

$$(F \circ G)(x) = F(G(x))$$

The parentheses enclosing $F \circ G$ insures that $F \circ G$ is thought of as a single object (function). The parentheses usually are omitted and one sees

$$F \circ G(x) = F(G(x))$$

³see the Web page, <http://www.heartdisease.org/Traits.html>

⁴Shirakawa, T. et al, *Science* **275** 1997, 77-79.

Without the parentheses, the novice reader may not know which of the following two ways to group

$$(F \circ G)(x) \quad \text{or} \quad F \circ (G(x))$$

The experienced reader knows the right hand way does not have meaning, so the left hand way must be correct.

In the “shivering example” above, the nerve cells that perceive the low temperature are the function G and the hypothalamus that sends signals to the muscle is the function F . The net result is that the cold signal increases the muscle tone. This relation may be diagrammed as in Figure 2.13. The arrows show the direction of information flow.

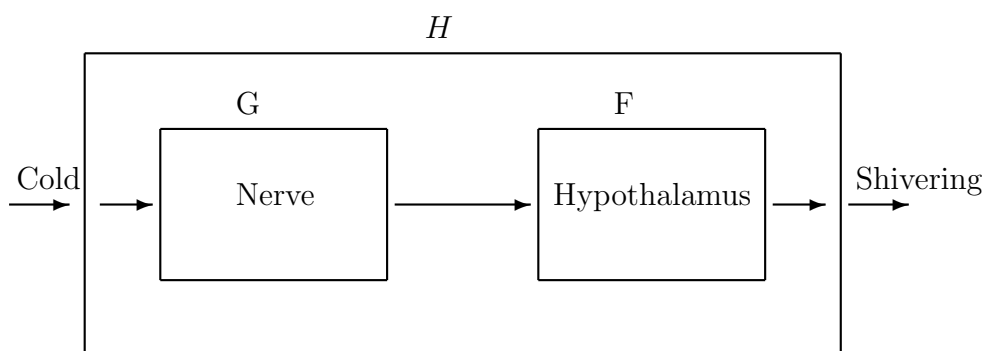

Figure 2.13: Diagram of the composition of F – increase of muscle tone by the hypothalamus – with G – stimulation from nerve cells by cold.

Formulas for function composition.

It is helpful to recognize that a complex equation defining a function is a composition of simple parts. For example

$$H(x) = \sqrt{1 - x^2}$$

is the composition of

$$F(z) = \sqrt{z} \quad \text{and} \quad G(x) = 1 - x^2 \quad F(G(x)) = \sqrt{1 - x^2}$$

The domain of G is all numbers but the domain of F is only $z \geq 0$ and the domain of $F \circ G$ is only $-1 \leq x \leq 1$.

The order of function composition is very important. For

$$F(z) = \sqrt{z} \quad \text{and} \quad G(x) = 1 - x^2,$$

the composition, $G \circ F$ is quite different from $F \circ G$.

$$F \circ G(x) = \sqrt{1 - x^2}$$

and its graph is a semicircle.

$$G \circ F(z) = G(F(z)) = 1 - (F(z))^2 = 1 - (\sqrt{z})^2 = 1 - z,$$

and its graph is part of a line (defined for $z \geq 0$).

Occasionally it is useful to recognize that a function is the composition of three functions, as in

$$K(x) = \log(\sin(x^2))$$

K is the composition, $F \circ G \circ H$ where

$$F(u) = \log(u) \quad G(v) = \sin(v) \quad H(x) = x^2$$

The composition of F and F^{-1} . The composition of a function with its inverse is special. The case of $F(x) = x^2$, $x \geq 0$ with $F^{-1}(x) = \sqrt{x}$ is illustrative.

$$(F \circ F^{-1})(x) = F(F^{-1}(x)) = F(\sqrt{x}) = (\sqrt{x})^2 = x \quad \text{for } x \geq 0$$

Also

$$(F^{-1} \circ F)(x) = F^{-1}(F(x)) = F^{-1}(x^2) = \sqrt{x^2} = x \quad \text{for } x \geq 0$$

The *identity function* I is defined by

$$I(x) = x \quad \text{for } x \text{ in a domain } D \tag{2.9}$$

where the domain D is adaptable to the problem at hand.

For $F(x) = x^2$ and $F^{-1}(x) = \sqrt{x}$, $F \circ F^{-1}(x) = F^{-1} \circ F(x) = x = I(x)$, where D should be $x \geq 0$. In the next paragraph we show that

$$F \circ F^{-1} = I \quad \text{and} \quad F^{-1} \circ F = I \tag{2.10}$$

for all invertible functions F .

The ordered pair (a, b) belongs to F^{-1} if and only if (b, a) belongs to F . Then

$$(F \circ F^{-1})(a) = F(F^{-1}(a)) = F(b) = a \quad \text{and} \quad (F^{-1} \circ F)(b) = F^{-1}(F(b)) = F^{-1}(a) = b$$

Always, $F \circ F^{-1} = I$ and with an appropriate domain D for I . Also $F^{-1} \circ F = I$ with possibly a different domain D for I .

Example 2.7.1 Two properties of the logarithm and exponential functions are

$$(a) \log_b b^\lambda = \lambda \quad \text{and} \quad (b) u = b^{\log_b u}$$

The logarithm function, $L(x) = \log_b(x)$ is the inverse of the exponential function, $E(x) = b^x$, and the properties simply state that

$$L \circ E = I \quad \text{and} \quad E \circ L = I \quad \blacksquare$$

■

The identity function composes in a special way with other functions.

$$(F \circ I)(x) = F(I(x)) = F(x) \quad \text{and} \quad (I \circ F)(x) = I(F(x)) = F(x)$$

Thus

$$F \circ I = F \quad \text{and} \quad I \circ F = F$$

Because 1 in the numbers has the property that

$$x \times 1 = x \quad \text{and} \quad 1 \times x = x$$

the number 1 is the identity for multiplication. Sometimes $F \circ G$ is thought of as multiplication also and I has the property analogous to 1 of the real numbers. Finally the analogy of

$$x x^{-1} = x \frac{1}{x} = 1 \quad \text{with} \quad F \circ F^{-1} = I$$

suggests a rationale for the symbol F^{-1} for the inverse of F .

With respect to function composition $F \circ G$ as multiplication, recall the example of $F(x) = \sqrt{x}$ and $G(x) = 1 - x^2$ in which $F \circ G$ and $G \circ F$ were two different functions. Composition of functions is not *commutative*, a property of real number multiplication that does not extend to function composition.

Exercises for Section 2.7 Composition of functions

Exercise 2.7.1 Four examples of composition of two biological processes (of two functions) were described at the beginning of this section on page 85. Write another example of the composition of two biological processes.

Exercise 2.7.2 Put labels on the diagrams in Figure Ex. 2.7.2 to illustrate the dependence of coyote numbers on rabbit *Myxomastix cuniculi* and the dependence of the frequency of heart attacks on diet of a population.

Figure for Exercise 2.7.2 Diagrams for Exercise 2.7.2

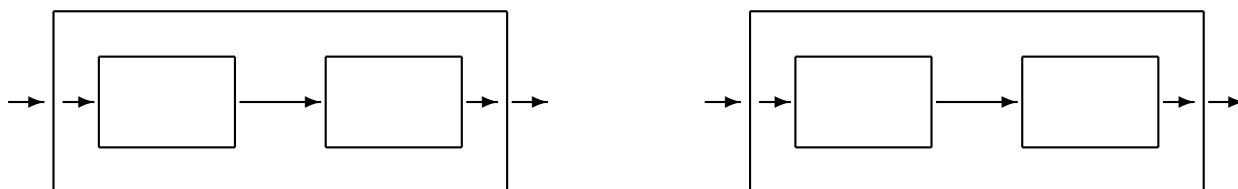

Exercise 2.7.3 a. In Explore 1.5.1 of Section 1.5 on page 25 you measured the area of the mold colony as a function of day. Using the same pictures in Figure 1.14, measure the *diameters* of the mold colony as a function of day and record them in Exercise Table 2.7.3. Remember that grid lines are separated by 2mm. Then use the formula, $A = \pi r^2$, for the area of a circle to compute the third column showing area as a function of day.

b. Determine the dependence of the colony diameter on time.

c. Use the composition of the relation between the area and diameter of a circle ($A = \pi r^2$) with the dependence of the colony diameter on time to describe the dependence of colony area on time.

Table for Exercise 2.7.3 Table for Exercise 2.7.3

Mold colony, page 26		
Day	Diameter	Area
0		
1		
2		
3		
4		
5		
6		
7		
8		
9		

Exercise 2.7.4 S. F. Elena, V. S. Cooper, and R. E. Lenski have grown an *V. natriegens* population for 3000 generations in a constant, nutrient limited environment. They have measured cell size and fitness of cell size and report (*Science* **272**, 1996, 1802-1804) data shown in the graphs below. The thrust of their report is the observed abrupt changes in fitness, supporting the hypothesis of “punctuated evolution.”

- Make a table showing cell size as a function of time for generations 0, 100, 200, 300, 400 and 500.
- Make a table showing fitness as a function of time for generations 0, 100, 200, 300, 400 and 500.
- Are the data consistent with the hypothesis of ‘punctuated equilibrium’?

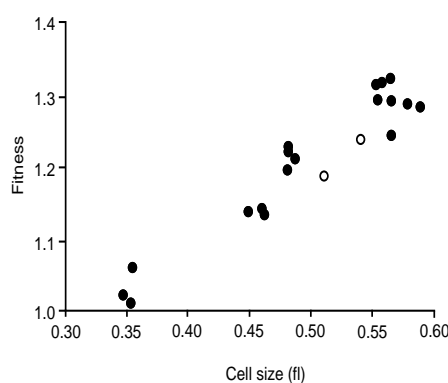
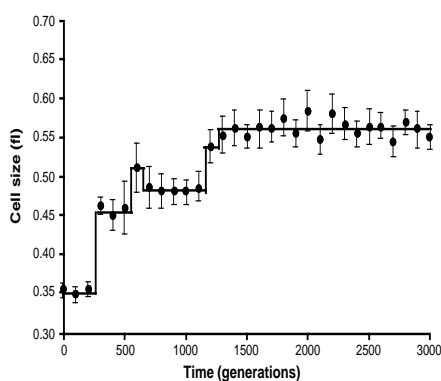

Exercise 2.7.5 Find functions, $F(z)$ and $G(x)$ so that the following functions, H , may be written as $F(G(x))$.

- | | | |
|----------------------------|-------------------------------------|----------------------------|
| a. $H(x) = (1 + x^2)^3$ | b. $H(x) = 10\sqrt{x}$ | c. $H(x) = \log(2x^2 + 1)$ |
| d. $H(x) = \sqrt{x^3 + 1}$ | e. $H(x) = \frac{1 - x^2}{1 + x^2}$ | f. $H(x) = \log_2(2^x)$ |

Exercise 2.7.6 Find functions, $F(u)$ and $G(v)$ and $H(x)$ so that the following functions, K , may be written as $F(G(H(x)))$.

- | | | |
|---------------------------------|-------------------------|-----------------------------|
| a. $K(x) = \sqrt{1 - \sqrt{x}}$ | b. $K(x) = (1 + 2^x)^3$ | c. $K(x) = \log(2x^2 + 1)$ |
| d. $K(x) = \sqrt{x^3 + 1}$ | e. $K(x) = (1 - 2^x)^3$ | f. $K(x) = \log_2(1 + 2^x)$ |

Exercise 2.7.7 Compute the compositions, $f(g(x))$, of the following pairs of functions. In each case specify the domain and range of the composite function, and sketch the graph. Your calculator may assist you. For example, the graph of part A can be drawn on the TI-86 calculator with GRAPH, $y(x) =$, $y1 = x^2$, $y2 = 1/(1+y1)$ You may wish to suppress the display of $y1$ with SELCT in the $y(x)=$ menu.

a. $f(z) = \frac{1}{1+z}$ $g(x) = x^2$	b. $f(z) = \frac{z}{1+z}$ $g(x) = \frac{x}{1-x}$	c. $f(z) = 5^z$ $g(x) = \log x$
d. $f(z) = \frac{1}{z}$ $g(x) = 1 + x^2$	e. $f(z) = \frac{z}{1-z}$ $g(x) = \frac{x}{1+x}$	f. $f(z) = \log z$ $g(x) = 5^x$
g. $f(z) = 2^z$ $g(x) = -x^2$	h. $f(z) = 2^z$ $g(x) = -1/x^2$	i. $f(z) = \log z$ $g(x) = 1 - x^2$

Exercise 2.7.8 For each part, find two pairs, F and G , so that $F \circ G$ is H .

a. $H(x) = \sqrt{1 - \sqrt{x}}$	b. $H(x) = \frac{1}{1 - \sqrt{x}}$	c. $H(x) = (1 + x^2)^3$
d. $H(x) = (x^{x^2})^3$	e. $H(x) = 2^{(x^2)}$	f. $H(x) = (2^x)^2$

Exercise 2.7.9 Air is flowing into a spherical balloon at the rate of $10 \text{ cm}^3/\text{s}$. What volume of air is in the balloon t seconds after there was no air in the balloon? The volume of a sphere of radius r is $V = \frac{4}{3}\pi r^3$. What will be the radius of the balloon t seconds after there is no air in the balloon?

Exercise 2.7.10 Why are all the points of the graph of $y = \log_{10}(\sin(x))$ on or below the X-axis? Why are there no points of the graph with x -coordinates between π and 2π ?

Exercise 2.7.11 Technology Draw the graph of the composition of $F(x) = 10^x$ with $G(x) = \log_{10} x$. Now draw the graph of the composition of G with F . Explain the difference between the two graphs.

Exercise 2.7.12 Let $P(x) = 2x^3 - 7x^2 + 5$ and $Q(x) = x^2 - x$. Use algebra to compute $Q(P(x))$. You may conclude (correctly) from this exercise that the composition of two polynomials is always a polynomial.

Exercise 2.7.13 Shown in Figure 2.7.13 is the graph of a function, G .

Sketch the graphs of

a. $G_a(x) = -3 + G(x)$	b. $G_b(x) = G((x - 3))$
c. $G_c(x) = 2 G(x)$	d. $G_d(x) = G(2 x)$
e. $G_e(x) = 5 - 2 G(x)$	f. $G_f(x) = G(2 (x - 3))$
g. $G_g(x) = 3 + G(2 (x - 3))$	h. $G_h(x) = 4 + G(x + 4)$

Figure for Exercise 2.7.13 Graph of G for Exercise 2.7.13.

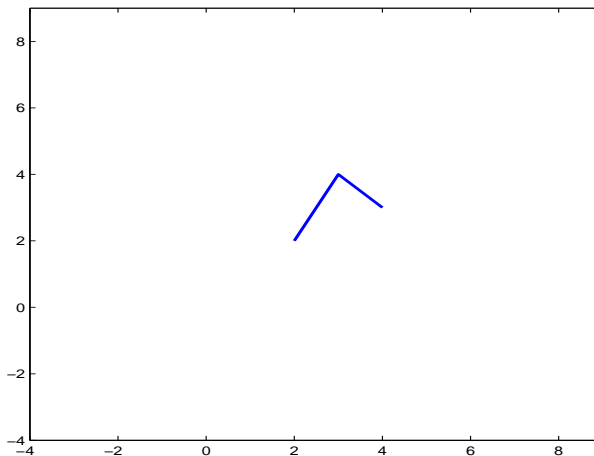

2.8 Periodic functions and oscillations.

There are many periodic phenomena in the biological sciences. Examples include wingbeat of insects and of birds, nerve action potentials, heart beat, breathing, rapid eye movement sleep, circadian rhythms (sleep-wake cycles), women’s menstrual cycle, bird migrations, measles incidence, locust emergence. All of these examples are periodic repetition with time, the variable usually associated with periodicity. The examples are listed in order of increasing period of repetition in Table 2.8.

Table 2.8: Characteristic periods of time-periodic biological processes.

Biological process	Period	Biological process	Period
Insect wingbeat	0.02 sec	Circadian cycle (sleep-wake)	1 day
Nerve action potential	0.2 sec	Menstrual cycle	28 days
Heart beat	1 sec	Bird migrations	1 year
Breathing (rest)	5 sec	Measles	2 years
REM sleep	\approx 90 min	Locust	17 years
Tides	6 hours		

A measurement usually quantifies the state of a process periodic with time and defines a function characteristic of the process. Some examples are shown in Figure 2.14. The measurement may be of physical character as in electrocardiograms, categorical as in stages of sleep, or biological as in measurement of hormonal level.

There are also periodic variations with space that result in the color patterns on animals – stripes on zebras and tigers, spots on leopards – , regular spacing of nesting sites, muscle striations, segments in a segmented worm, branching in nerve fibers, and the five fold symmetry of echinoderms. Some spatially periodic structures are driven by time-periodic phenomena – branches in a tree, annular tree rings, chambers in a nautilus, ornamentation on a snail shell. The pictures in Figure 2.8 illustrate some periodic functions that vary with linear space. The brittle star shown in Figure 2.16 varies periodically with angular change in space.

In all instances there is an independent variable, generally time or space, and a dependent variable that is said to be periodic.

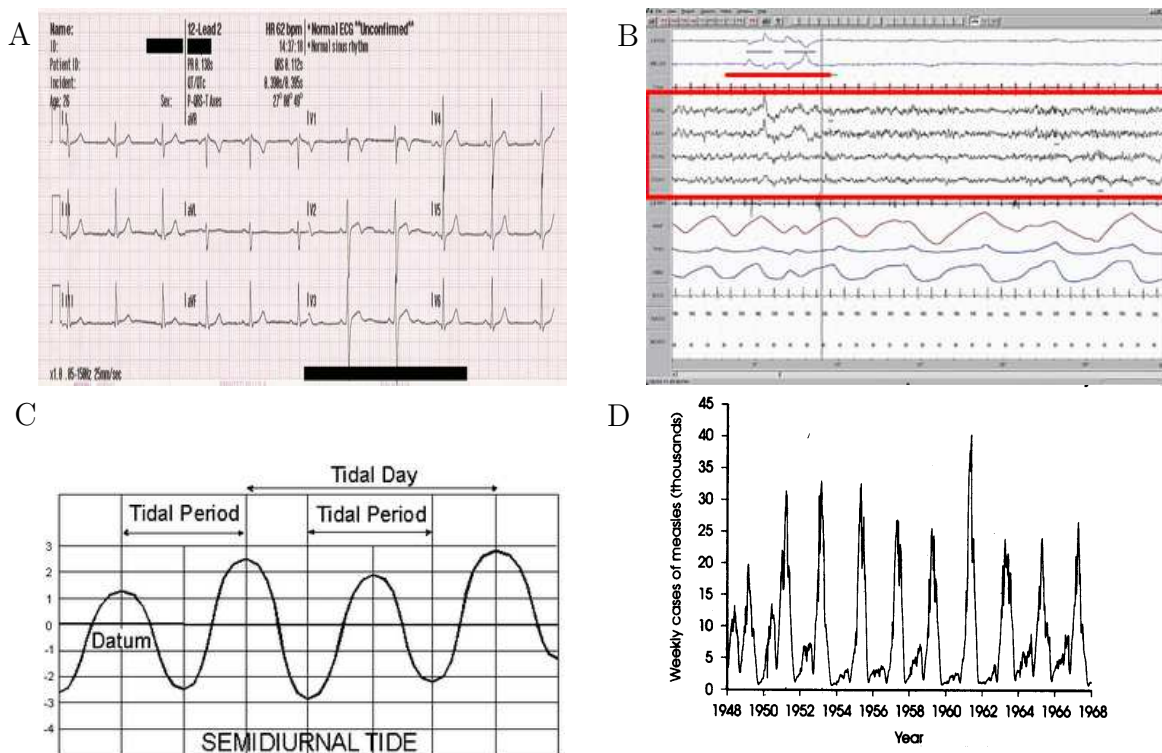

Figure 2.14: Figures demonstrating periodic repetition with time. (A) Eelectrocardiogram. <http://en.wikipedia.org/wiki/Electrocardiography> uploaded by MoodyGroove. (B) This is a screenshot of a polysomnographic record (30 seconds) representing Rapid Eye Movement Sleep. EEG highlighted by red box. Eye movements highlighted by red line. <http://en.wikipedia.org/wiki/File:REM.png> uploaded by Mr. Sandman. (C) Tidal movement (≈ 12 hr) (<http://en.wikipedia.org/wiki/Tide>), uploaded from NOAA, <http://co-ops.nos.noaa.gov/images/restfig6.gif>. (D) Recurrent epidemics of measles (≈ 2 yr), Anderson and May, Vaccination and herd immunity to infectious diseases, *Nature* **318** 1985, pp 323-9, Figure 1a.

Definition 2.8.1 Periodic Function. A function, F , is said to be periodic if there is a positive number, p , such that for every number x in the domain of F , $x + p$ is also in the domain of F and

$$F(x + p) = F(x). \tag{2.11}$$

and for each number q where $0 < q < p$ there is some x in the domain of F for which

$$F(x + q) \neq F(x)$$

The period of F is p .

The **amplitude** of a periodic function F is one-half the difference between the largest and least values of $F(t)$, when these values exist.

The condition that ‘for every number x in the domain of F , $x + p$ is also in the domain of F ’ implies that the domain of F is infinite in extent — it has no upper bound. Obviously, all of the



Figure 2.15: Figures demonstrating periodic repetition with space. A. Muscle striations, Kansas University Medical School, <http://www.kumc.edu/instruction/medicine/anatomy/histoweb/muscular/muscle02.htm>. B. Bristle worm, <http://www.photolib.noaa.gov/htmls/reef1016.htm> Image ID: reef1016, Dr. Anthony R. Picciolo. C. Annular rings, uploaded by Arnoldius to commons.wikimedia.org/wiki D. A common genet (*Genetta genetta*), [http://en.wikipedia.org/wiki/File:Genetta_genetta_felina_\(Wroclaw_zoo\).JPG](http://en.wikipedia.org/wiki/File:Genetta_genetta_felina_(Wroclaw_zoo).JPG) Uploaded by Guérin Nicolas. Note a periodic distribution of spots on the body and stripes on the tail.

examples that we experience are finite in extent and do not satisfy Definition 2.8.1. We will use ‘periodic’ even though we do not meet this requirement.

The condition ‘when these numbers exist’ in the definition of amplitude is technical and illustrated in Figure 2.17 by the graph of

$$F(t) = t - [t]$$

where $[t]$ denotes the integer part of t . ($[\pi] = 3$, $[\sqrt{30}] = 5$). There is no largest value of $F(t)$.

$$F(n) = n - [n] = 0 \quad \text{for integer } n$$

If t is such that $F(t)$ is the largest value of F then t is not an integer and is between an integer n and $n + 1$. The midpoint s of $[t, n + 1]$ has the property that $F(t) < F(s)$, so that $F(t)$ is not the largest value of F .

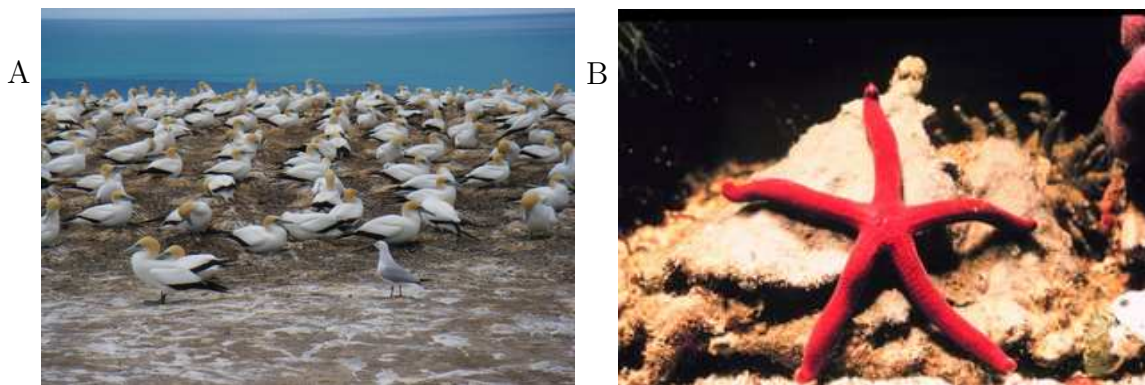

Figure 2.16: A. Periodic distribution of Gannet nests in New Zealand. B. A star fish demonstrating angular periodicity, NOAA’s Coral Kingdom Collection, Dr. James P. McVey, <http://www.photolib.noaa.gov/htmls/reef0296.htm>.

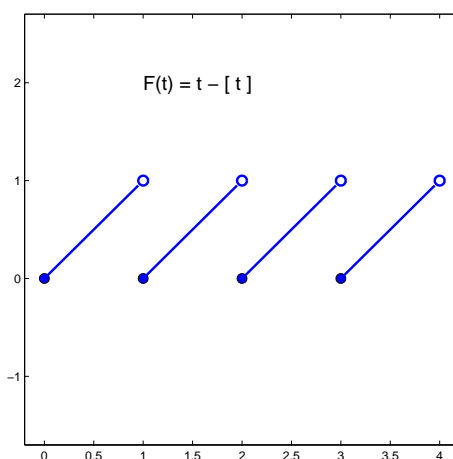

Figure 2.17: The graph of $F(t) = t - [t]$ has no highest point.

The function, $F(t) = t - [t]$ is pretty clearly periodic of period 1, and we might say that its amplitude is 0.5 even though it does not satisfy the definition for amplitude. Another periodic function that has no amplitude is the tangent function from trigonometry.

Periodic Extension Periodic functions in nature do not strictly satisfy Definition 2.8.1, but can be approximated with strictly periodic functions over a finite interval of their domain. Periodic functions in nature also seldom have simple equation descriptions. However, one can sometimes describe the function over one period and then assert that the function is periodic – thus describing the entire function.

Example 2.8.1 Electrocardiograms have a very characteristic periodic signal as shown in Figure 2.14.

A picture of a typical signal from ‘channel I’ is shown in Figure 2.18; the regions of the signal, P-R, QRS, etc. correspond to electrical events in the heart that cause contractions of specific muscles. Is there an equation for such a signal? Yes, a very messy one!

The graph of the following equation is shown in Figure 2.18(b). It is similar to the typical

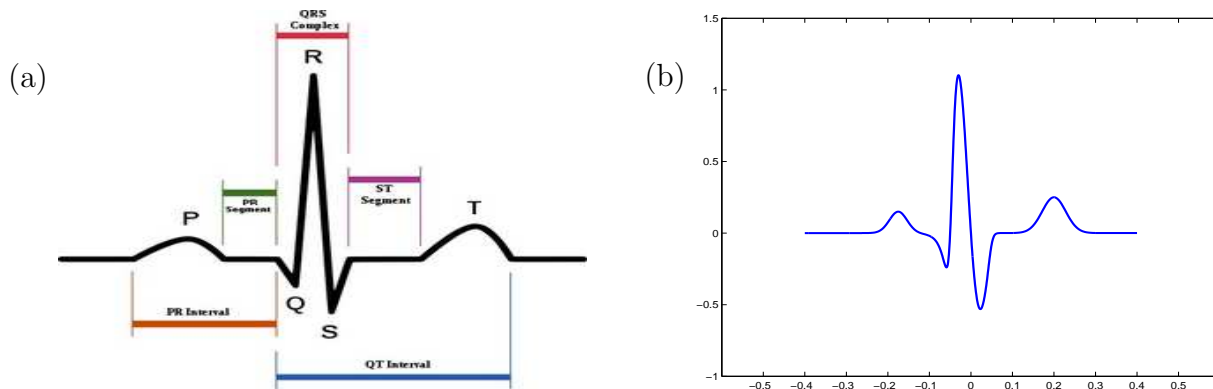

Figure 2.18: (a) Typical signal from an electrocardiogram, created by Agateller (Anthony Atkielski) <http://en.wikipedia.org/wiki/Electrocardiography>, . (b) Graph of Equation 2.12

electrocardiogram in Figure 2.18(a).

$$H(t) = 25000 \frac{(t + 0.05) t (t - 0.07)}{(1 + (20t)^{10}) 2^{(2^{40t})}} + 0.15 2^{-1600(t+0.175)^2} + 0.25 2^{-900(t-0.2)^2}$$

$$-0.4 \leq t \leq 0.4$$
(2.12)

Explore 2.8.1 Technology Draw the graph of the heart beat Equation 2.12. You will find it useful to break the function into parts. It is useful to define

$$y1 = 25000 \frac{(x + 0.05) x (x - 0.07)}{(1 + (20x)^{10})}$$

$$y2 = (y1)/2^{(2^{40x})}$$

and $y3$ and $y4$ for the other two terms, then combine $y2$, $y3$ and $y4$ into $y5$ and select only $y5$ to graph. ■

The heart beat function H in Equation 2.12 is not a periodic function and is defined only for $-0.4 \leq t \leq 0.4$. Outside that interval, the expression defining $H(t)$ is essentially zero. However, we can simultaneously extend the definition of H and make it periodic by

$$H(t) = H(t - 0.8) \quad \text{for all } t$$

What is the impact of this? $H(0.6)$, say is now defined, to be $H(-0.2)$. Immediately, H has meaning for $0.4 \leq t \leq 1.2$, and the graph is shown in Figure 2.19(a). Now because $H(t)$ has meaning on $0.4 \leq t \leq 1.2$, H also has meaning on $0.4 \leq t \leq 2.0$ and the graph is shown in Figure 2.19(b). The extension continues indefinitely. ■ ■

Definition 2.8.2 *Periodic extension of a function.* If f is a function defined on an interval $[a, b)$ and $p = b - a$, the periodic extension of F of f is defined by

$$F(t) = f(t) \quad \text{for } a \leq t < b,$$

$$F(t + p) = F(t) \quad \text{for } -\infty < t < \infty$$
(2.13)

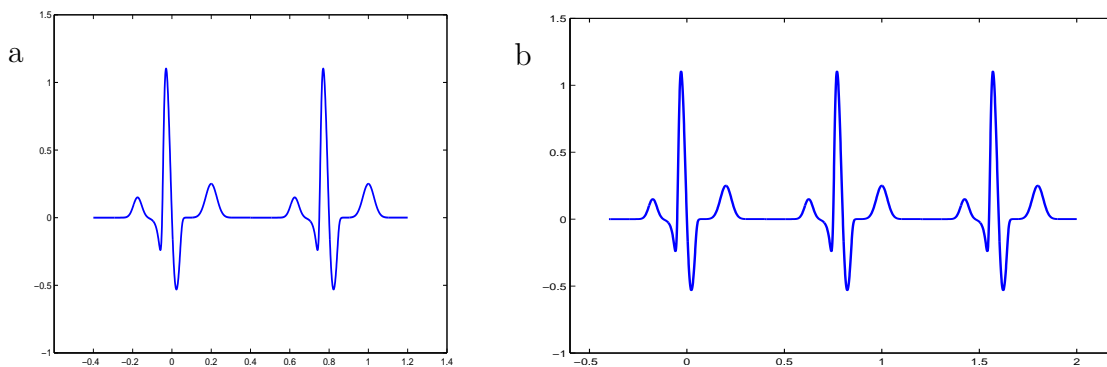

Figure 2.19: (a) Periodic extension of the heart beat function H of Equation 2.12 by one period. (a) Periodic extension of the heart beat function H to two periods.

Equation 2.13 is used recursively. For t in $[a, b)$, $t + p$ is in $[b, b + p)$ and Equation 2.13 defines F on $[b, b + p)$. Then, for t in $[b, b + p)$, $t + p$ is in $[b + p, b + 2p)$ and Equation 2.13 defines F on $[b + p, b + 2p)$. Continue this for all values of $t > b$. If t is in $[a - p, a)$ then $t + p$ is in $[a, b)$ and $F(t) = F(t + p)$. Continuing in this way, F is defined for all t less than a .

Exercises for Section 2.8, Periodic functions and oscillations.

Exercise 2.8.1 Which of the three graphs in Figure Ex. 2.8.1 are periodic. For any that is periodic, find the period and the amplitude.

Figure for Exercise 2.8.1 Three graphs for Exercise 2.8.1 .

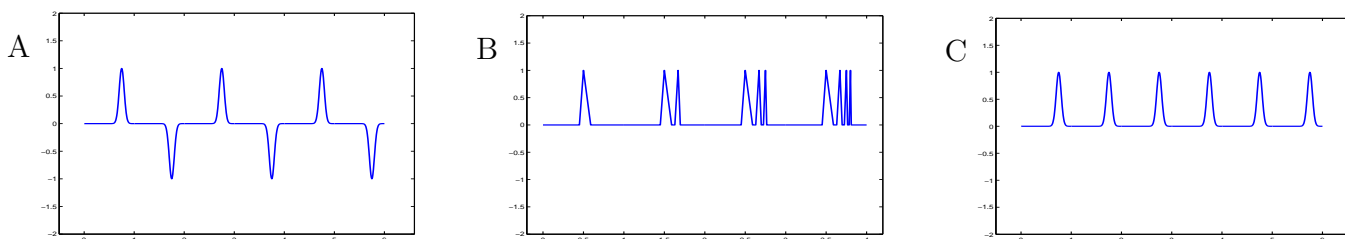

Exercise 2.8.2 Shown in Figure Ex. 2.8.2 is the graph of a function, f defined on the interval $[1, 6]$. Let F be the periodic extension of f .

- a. What is the period of F ?
- b. Draw a graph of F over three periods.
- c. Evaluate $F(1)$, $F(3)$, $F(8)$, $F(23)$, $F(31)$ and $F(1004)$.
- d. Find the amplitude of F .

Figure for Exercise 2.8.2 Graph of a function f for Exercise 2.8.2 .

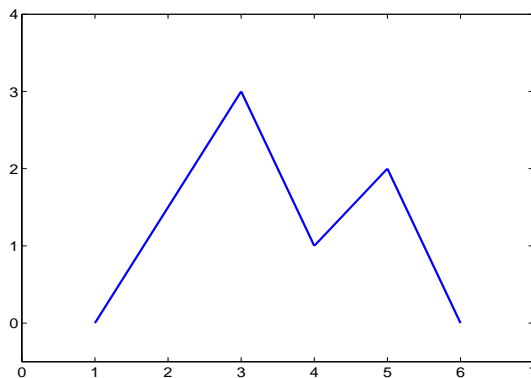

Exercise 2.8.3 Suppose you are traveling an interstate highway and that every 10 miles there is an emergency telephone. Let D be the function defined by

$D(x)$ is the distance to the nearest emergency telephone

where x is the mileage position on the highway.

- a. Draw a graph of D .
- b. Find the period and amplitude of D .

Exercise 2.8.4 Your 26 inch diameter bicycle wheel has a patch on it. Let P be the function defined by

$P(x)$ is the distance from patch to the ground

where x is the distance you have traveled on a bicycle trail.

- a. Draw a graph of P (approximate is acceptable).
- b. Find the period and amplitude of P .

Exercise 2.8.5 Let F be the function defined for all numbers, x , by

$F(x) =$ the distance from x to the even integer nearest x .

- a. Draw a graph of F .
- b. Find the period and amplitude of F .

Exercise 2.8.6 Let f be the function defined by

$$f(x) = 1 - x^2 \quad -1 \leq x \leq 1$$

Let F be the extension of f with period 2.

- a. Draw a graph of f .
- b. Draw a graph of F .
- c. Evaluate $F(1)$, $F(2)$, $F(3)$, $F(12)$, $F(31)$ and $F(1002)$.
- d. Find the amplitude of F .

2.8.1 Trigonometric Functions.

The trigonometric functions are perhaps the most familiar periodic functions and often are used to describe periodic behavior. However, not many of the periodic functions in biology are as simple as the trigonometric functions, even over restricted domains.

Amplitude and period and frequency of a Cosine Function. The function

$$H(t) = A \cos\left(\frac{2\pi}{P}t + \phi\right) \quad A > 0 \quad P > 0$$

and ϕ any angle has amplitude A , period P , and frequency $1/P$.

Graphs of rescaled cosine functions shown in Figure 2.20 demonstrate the effects of A and P .

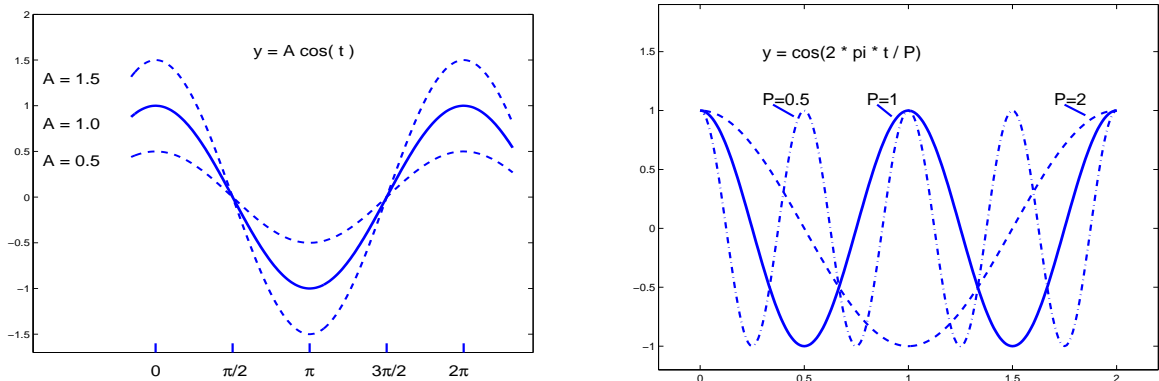

Figure 2.20: (a) Graphs of the cosine function for amplitudes 0.5, 1.0 and 1.5. (b) Graphs of the cosine function for periods 0.5, 1.0 and 2.0.

Example 2.8.2 Problem. Find the period, frequency, and amplitude of

$$H(t) = 3 \sin(5t + \pi/3)$$

Solution. Write $H(t) = 3 \sin(5t + \pi/3)$ as

$$H(t) = 3 \sin\left(\frac{2\pi}{2\pi/5}t + \pi/3\right).$$

Then the amplitude of P is 3, and the period is $2\pi/5$ and the frequency is $5/(2\pi)$. ■

Motion of a Spring-Mass System A mass suspended from a spring, when vertically displaced from equilibrium a small amount will oscillate above and below the equilibrium position. A graph of displacement from equilibrium *vs* time is shown in in Figure 2.21A for a certain system. Critical points of the graph are

$$(2.62 \text{ s}, 72.82 \text{ cm}), \quad (3.18 \text{ s}, 46.24 \text{ cm}), \quad \text{and} \quad (3.79 \text{ s}, 72.80 \text{ cm})$$

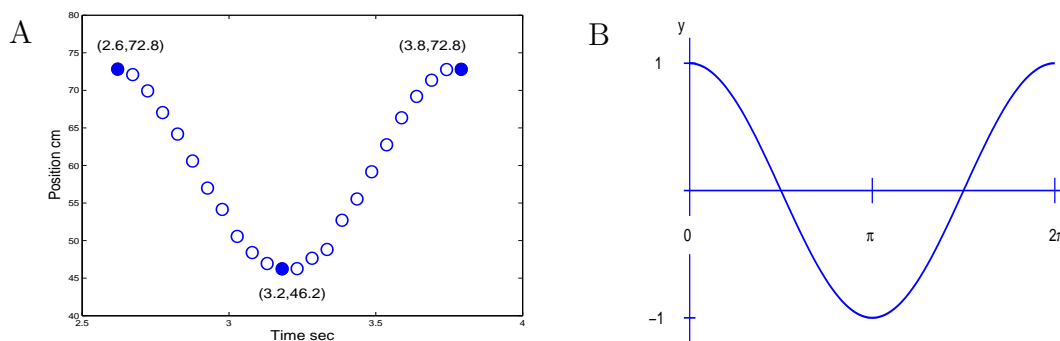

Figure 2.21: Graphs of A. the motion of a spring-mass system and B. $H(t) = \cos t$.

Also shown is the graph of the cosine function, $H(t) = \cos t$.

It is clear that the data and the cosine in Figure 2.21 have similar shapes, but examine the axes labels and see that their periods and amplitudes are different and the graphs lie in different regions of the plane. We wish to obtain a variation of the cosine function that will match the data.

The period of the harmonic motion is $3.79 - 2.62 = 1.17$ seconds, the time of the second peak minus the time of the first peak. The amplitude of the harmonic motion is $0.5(72.82 - 46.24) = 13.29$ cm, one-half the difference of the heights of the highest and lowest points.

Now we expect a function of the form

$$H_0(t) = 13.3 \cos\left(\frac{2\pi}{1.17}t\right)$$

to have the shape of the data, but we need to translate vertically and horizontally to match the data. The graphs of H_0 and the data are shown in Figure 2.22A, and the shapes are similar. We need to match the origin (0,0) with the corresponding point (2.62, 59.5) of the data. We write

$$H(t) = 59.5 + 13.3 \cos\left(\frac{2\pi}{1.17}(t - 2.62)\right)$$

The graphs of H and the data are shown in Figure 2.22B and there is a good match.

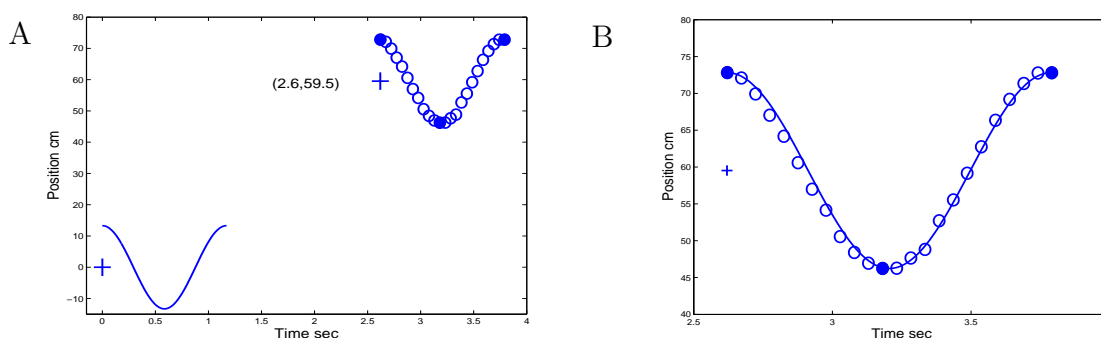

Figure 2.22: On the left is the graph of $H_0(t) = 13.3 \cos\left(\frac{2\pi}{1.17}t\right)$ and the harmonic oscillation data. The two are similar in form. The graph to the right shows the translation, H , of H_0 , $H(t) = 59.5 + 13.3 \cos\left(\frac{2\pi}{1.17}(t - 2.62)\right)$ and its approximation to the harmonic oscillation data.

Polynomial approximations to the sine and cosine functions. Shown in Figure 2.23 are the graphs of $F(x) = \sin x$ and the graph of (dashed curve)

$$P_3(x) = x - \frac{x^3}{120}$$

on $[0, \pi/2]$.

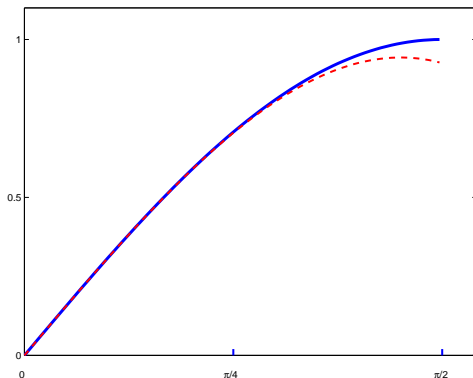

Figure 2.23: The graphs of $F(x) = \sin x$ (solid) and $P_3(x) = x - \frac{x^3}{120}$ (dashed) on $[0, \pi/2]$.

The graph of P_3 is hardly distinguishable from the graph of F on the interval $[0, \pi/4]$, although they do separate near $x = \pi/2$. $F(x) = \sin x$ is difficult to evaluate (without a calculator) except for special values such as $F(0) = \sin 0 = 0$, $F(\pi/3) = \sin \pi/3 = 0.5$ and $F(\pi/2) = \sin \pi/2 = 1.0$. However, $P_3(x)$ can be calculated using only multiplication, division and subtraction. The maximum difference between P_3 and F on $[0, \pi/4]$ occurs at $\pi/4$ and $F(\pi/4) = \sqrt{2}/2 \doteq 0.70711$ and $P_3(\pi/4) = 0.70465$. The relative error in using $P_3(\pi/4)$ as an approximation to $F(\pi/4)$ is

$$\text{Relative Error} = \frac{|P_3(\pi/4) - F(\pi/4)|}{F(\pi/4)} \doteq \frac{|0.70465 - 0.70711|}{0.70711} = 0.0036$$

thus less than 0.5% error is made in using the rather simple $P_3(x) = x - (x^3)/120$ in place of $F(x) = \sin x$ on $[0, \pi/4]$.

Exercises for Section 2.8.1, Trigonometric functions.

Exercise 2.8.7 Find the periods of the following functions.

- | | |
|----------------------------------|---|
| a. $P(t) = \sin(\frac{\pi}{3}t)$ | d. $P(t) = \sin(t) + \cos(t)$ |
| b. $P(t) = \sin(t)$ | e. $P(t) = \sin(\frac{2\pi}{2}t) + \sin(\frac{2\pi}{3}t)$ |
| c. $P(t) = 5 - 2\sin(t)$ | f. $P(t) = \tan 2t$ |

Exercise 2.8.8 Sketch the graphs and label the axes for

(a) $y = 0.2 \cos\left(\frac{2\pi}{0.8}t\right)$ and (b) $y = 5 \cos\left(\frac{1}{8}t + \pi/6\right)$

Exercise 2.8.9 Describe how the harmonic data of Figure 2.22A would be translated so that the graph of the new data would match that of H_0 .

Exercise 2.8.10 Use the identity, $\cos t = \sin(t + \frac{\pi}{2})$, to write a sine function that approximates the harmonic oscillation data.

Exercise 2.8.11 Fit a cosine function to the spring-mass oscillation shown in Exercise Figure 2.8.11.

Figure for Exercise 2.8.11 Graph of a spring-mass oscillation for Exercise 2.8.11.

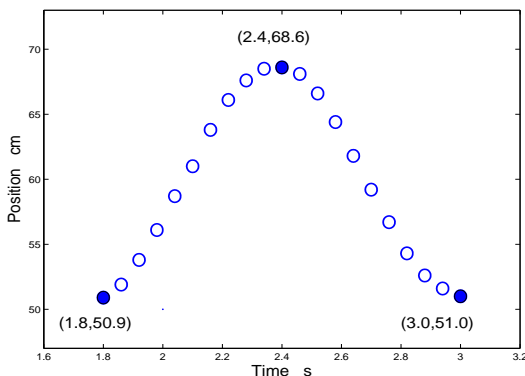

Exercise 2.8.12 A graph of total marine animal diversity over the period from 543 million years ago until today is shown in Exercise Figure 2.8.12A. The data appeared in a paper by Robert A. Rohde and Richard A. Muller⁵, and are based on work by J. John Sepkoski⁶. Also shown is a cubic polynomial fit to the data by Robert Rohde and Richard Muller who were interested in the the difference between the data and the cubic shown in Exercise Figure 2.8.12B. They found that a sine function of period 62 million years fit the residuals rather well. Find an equation of such a sine function.

Figure for Exercise 2.8.12 A. Marine animal diversity and a cubic polynomial fit to the data. B. The residuals of the cubic fit. Figures adapted from Robert A. Rohde and Richard A. Muller, Cycles in fossil diversity, *Nature* 434, 208-210, Copyright 2005, <http://www.nature.com>

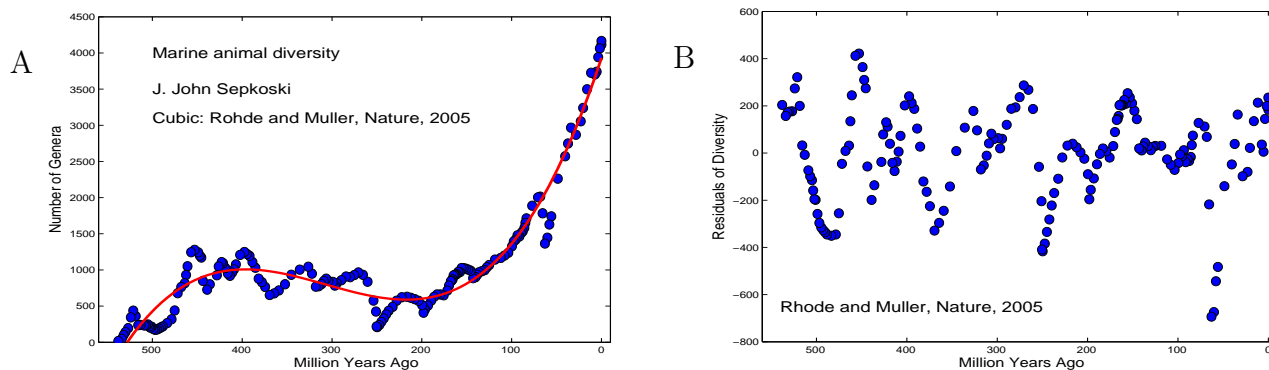

Exercise 2.8.13 Technology Draw the graphs of $F(x) = \sin x$ and

$$F(x) = \sin x \quad \text{and} \quad P_5(x) = x - \frac{x^3}{6} + \frac{x^5}{120}$$

on the range $0 \leq x \leq \pi$. Compute the relative error in $P_5(\pi/4)$ as an approximation to $F(\pi/4)$ and in $P_5(\pi/2)$ as an approximation to $F(\pi/2)$.

Exercise 2.8.14 Technology Polynomial approximations to the cosine function.

⁵Robert A. Rohde and Richard A. Muller, Cycles in fossil diversity, *Nature* 434, 208-210.

⁶J. John Sepkoski, A compendium of Fossil Marine Animal Genera, Eds David Jablonski and Michael Foote, *Bulletins of AMerican Paleontology*, 363, 2002.

- a. Draw the graphs of $F(x) = \cos x$ and

$$F(x) = \cos x \quad \text{and} \quad P_2(x) = 1 - \frac{x^2}{2}$$

on the range $0 \leq x \leq \pi$.

- b. Compute the relative error in $P_2(\pi/4)$ as an approximation to $F(\pi/4)$ and in $P_2(\pi/2)$ as an approximation to $F(\pi/2)$.

- c. Use a graphing calculator to draw the graphs of $F(x) = \cos x$ and

$$P_4(x) = 1 - \frac{x^2}{2} + \frac{x^4}{24}$$

on the range $0 \leq x \leq \pi$.

- d. Compute the relative error in $P_4(\pi/4)$ as an approximation to $F(\pi/4)$ and the absolute error in $P_4(\pi/2)$ as an approximation to $F(\pi/2)$.

Chapter 3

The Derivative

Where are we going?

In this chapter, you will learn about the rate of change of a function, a concept at the heart of calculus.

Suppose F is a function.

The *rate of change of F* at a point a in its domain is the slope of the tangent to the graph of F at $(a, F(a))$, if such a tangent exists.

The slope of the tangent at $(a, F(a))$ is approximated by slopes of lines through $(a, F(a))$ and points $(b, F(b))$ when b is close to a .

We initiate the use of rate of change to form models of biological systems.

The *rate of change* of a function F at a number a is the *slope of the tangent* to the graph of F at the point $(a, F(a))$.

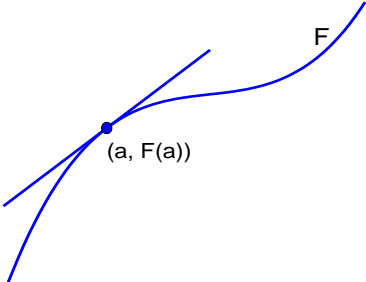

As $(b, f(b))$ approaches $(a, f(a))$ the *slope of the secant* through $(a, f(a))$ and $(b, f(b))$ approaches the slope of the tangent to F at $(a, F(a))$.

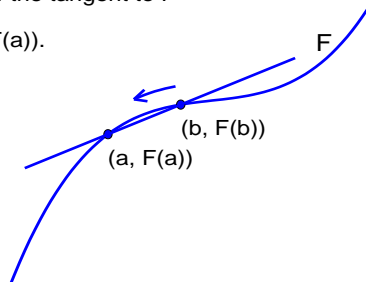

Calculus is the study of change and rates of change. It has two primitive concepts, the *derivative* and the *integral*. Given a function relating a dependent variable to an independent variable, the derivative is the *rate of change* of the dependent variable as the independent variable changes. We determine the derivative of a function when we answer questions such as

1. Given population size as a function of time, at what rate is the population growing?
2. Given the position of a particle as a function of time, what is its velocity?

3. At what rate does air density decrease with increasing altitude?
4. At what rate does the pressure of one mole of O_2 at $300^\circ K$ change as the volume changes if the temperature is constant?

On the other hand, given the rate of change of a dependent variable as an independent variable changes, the integral is the function that relates the dependent variable to the independent variable.

1. Given the growth rate of a population at all times in a time interval, how much did the population size change during that time interval?
2. Given the rate of renal clearance of penicillin during the four hours following an initial injection, what will be the plasma penicillin level at the end of that four hour interval?
3. Given that a car left Chicago at 1:00 pm traveling west on I80 and given the velocity of the car between 1 and 5 pm, where was the car at 5 pm?

The derivative is the subject of this chapter; the integral is addressed in Chapter 9. The derivative and integral are independently defined. Chapter 9 can be studied before this one and without reference to this one. The two concepts are closely related, however, and the relation between them is The Fundamental Theorem of Calculus, developed in Chapter 10.

Explore 3.0.2 You use both the derivative and integral concepts of calculus when you cross a busy street. You observe the nearest oncoming car and subconsciously estimate its distance from you and its speed (use of the derivative), and you decide whether you have time to cross the street before the car arrives at your position (a simple use of the integral). Might there be a car different from the nearest car that will affect your estimate of the time available to cross the street? You may even observe that the car is slowing down and you may estimate whether it will stop before it gets to your crossing point (involves the integral). It gets really difficult when you are traveling on a two-lane road and want to pass a car in front of you and there is an oncoming vehicle. Teenage drivers learn calculus.

Give an example in which estimates of distances and speeds and times are important for successful performance in a sport. ■

3.1 Tangent to the graph of a function

Elementary and very important.

Consider a line with equation,

$$y = mx + b.$$

The slope, m , of the line is computed as the increment in y divided by the increment in x between two points of the line, and may be called **the rate of change of y with respect to x .**

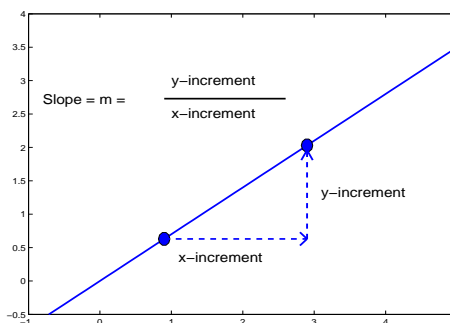

- If y measures bacterial population size at time x measured in hours, the slope m is the bacterial increase per hour, or bacterial growth rate, with dimensions, pop/hour.
- If y measures the height of a young girl in inches at year x , then m is the growth rate of the girl in inches per year.
- If y measures a morphogen concentration a distance x from its source in a developing embryo, m is the rate of concentration decrease, called a morphogenetic gradient, that causes differentiation of specific cell types in a distinct spatial order.

The simple rate of change of linear functions is crucial to understanding the rate of change of nonlinear functions.

Example 3.1.1 At what rate was the *Vibrio natriegens* population of Section 1.1 growing at time $T = 40$ minutes?

We have data for population density (measured in absorbance units) at times $T = 0, T = 16, T = 32, T = 48, T = 64,$ and $T = 80,$ minutes.

Time	0	16	32	48	64	80
Absorbance	0.022	0.036	0.060	0.101	0.169	0.266

The average growth rate between times $T = 32$ and $T = 48$ is

$$\frac{0.101 - 0.060}{48 - 32} = 0.0026 \quad \frac{\text{Absorbance units}}{\text{minute}},$$

and is a pretty good estimate of the growth rate at time $T = 40$, particularly because 40 is midway between 32 and 48.

In Section 1.1 we let t index time in 16 minutes intervals, and we used the mathematical model that population increase during time t to $t + 1$ is proportional to the population at time t . With B_t being population at time index t , we wrote

$$B_{t+1} - B_t = r \times B_t \quad \text{for} \quad t = 0, 1, 2, 3, 4, 5,$$

We concluded that

$$B_t = 0.022 \left(\frac{5}{3}\right)^t, \quad \text{for } t = 0, 1, 2, 3, 4, 5. \quad (3.1)$$

In terms of T in minutes and $B(T)$ in absorbance units, (Equation 1.5)

$$B(T) = 0.022 \left(\frac{5}{3}\right)^{T/16} = 0.022 \cdot 1.032^T. \quad (3.2)$$

Shown in Figure 3.1A are the data, the discrete computations of Equation 3.1 and the graph of Equation 3.2. A magnification of the graph near $T = 40$ minutes is shown Figure 3.1B together with a tangent drawn at $(40, B(40))$.

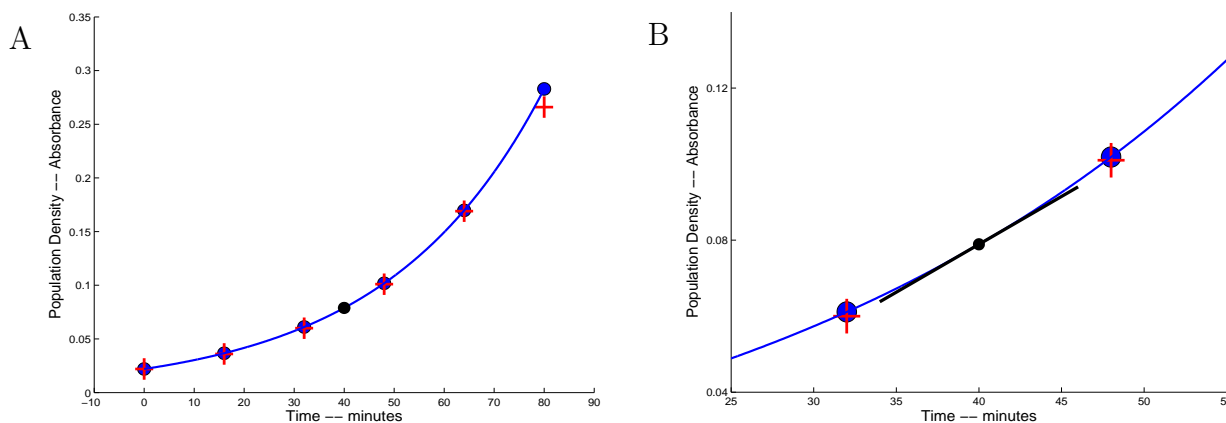

Figure 3.1: A. Graph of the *V. natriegens* data (+), the discrete approximation of Equation 3.1 (filled circles) and the graph of Equation 3.2. A magnification near $T = 40$ minutes is shown in B together with a tangent to the graph of $B(T)$ (Equation 3.2) at $(40, B(40))$.

We **define** the (instantaneous) growth rate of a population described by $B(T)$ at time $T = 40$ to be the slope of the tangent to the graph of B at time $T = 40$. The units on the slope of the tangent are

$$\frac{\text{change in } y}{\text{change in } x} = \frac{\text{Absorbance units}}{\text{Time in seconds}}$$

and are appropriate for population growth rate. Shown in Figure 3.2 are the tangent and a secant line between $(32, B(32))$ and $(48, B(48))$. The slope of the secant is

$$\frac{B(48) - B(32)}{48 - 32} = \frac{0.10185 - 0.06111}{16} = 0.002546$$

This is the average growth rate of B and is slightly different from the average growth rate (0.0026) computed from the data because B only approximates the data (pretty well, actually) and can be computed with higher accuracy than is possible with the data.

We can compute a closer estimate of the slope of the tangent by computing

$$\frac{B(45) - B(35)}{45 - 35} = \frac{0.092549 - 0.067254}{10} = 0.0025295.$$

It would be possible to have absorbance data at 5 minute intervals and compute the average growth rate between 35 and 45 minutes, but there are two difficulties. The main difficulty is that absorbance (on our machine) can only be measured to three decimal digits and the answer could be

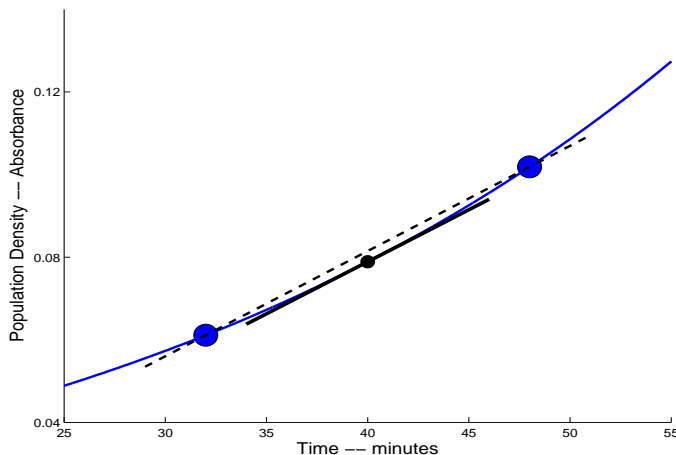

Figure 3.2: Graph of $B(T)$, the tangent to the graph at $(40, B(40))$ and the secant through $(32, B(32))$ and $(48, B(48))$.

trusted to only 3 decimal digits, the first of which is 0. A second problem is that at each reading, 10 ml of growth serum is extracted, analyzed in the spectrophotometer, and discarded. In 80 minutes, 160 ml of serum would be discarded, possibly more than was initially present.



Example 3.1.2 At what rate was the world human population increasing in 1980? Shown in Figure 3.3 are data for the twentieth century and a graph of an approximating function, F . A tangent to the graph of F at $(1980, F(1980))$ is drawn and has a slope of $0.0781 \cdot 10^9 = 78,100,000$. Now,

$$\text{slope is } \frac{\text{rise}}{\text{run}} = \frac{\text{change in population}}{\text{change in years}} \approx \frac{\text{people}}{\text{year}}.$$

The units of slope, then, are people/year. Therefore,

$$\text{slope} = 78,100,000 \frac{\text{people}}{\text{year}}.$$

The world population was increasing approximately 78,100,000 people per year in 1980.

Explore 3.1.1 At approximately what rate was the world human population increasing in 1920?



Definition 3.1.1 Rate of change of a function at a point. If the graph of a function, F , has a tangent at a point $(a, F(a))$, then the rate of change of F at a is the slope of the tangent to F at the point $(a, F(a))$.

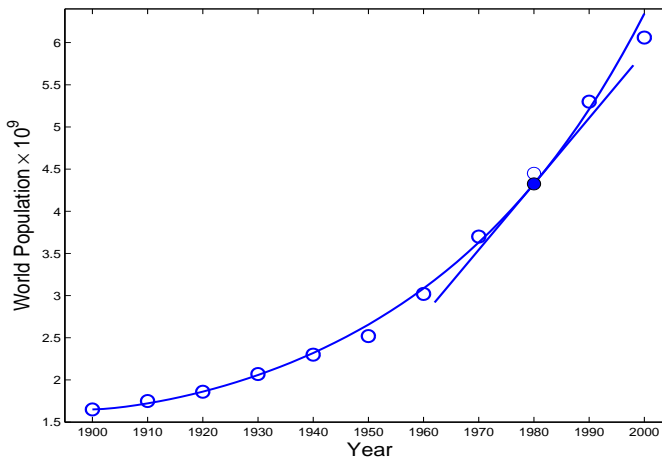

Figure 3.3: Graph of United Nations estimates of world human population for the twentieth century, an approximating curve, and a tangent to the curve. The slope of the tangent is $0.0781 \cdot 10^9 = 78,100,000$.

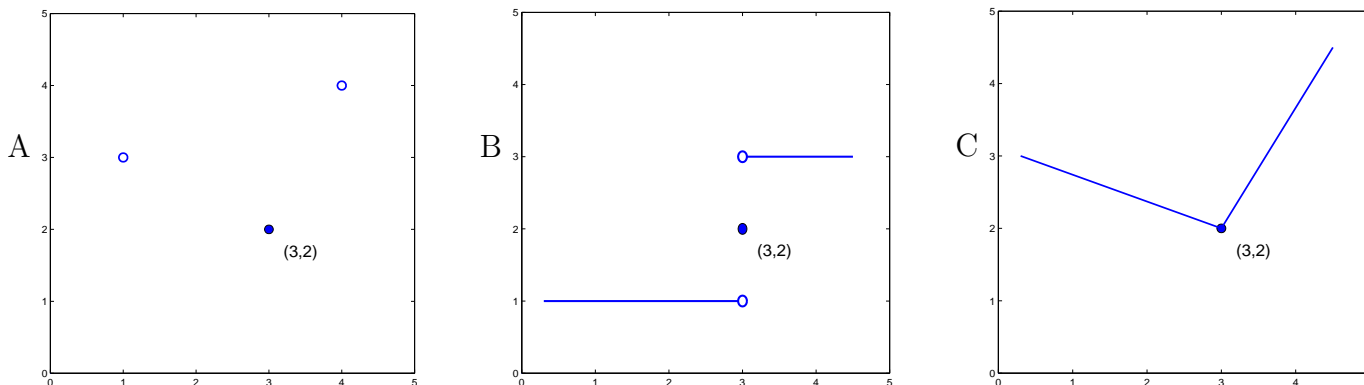

Figure 3.4: In neither of these graphs will we accept a line as tangent to the graph at the point (3,2)

To be of use, Definition 3.1.1 requires a definition of tangent to a graph which is given below in Definition 3.1.3. In some cases there will be no tangent. In each graph shown in Figure 3.4 there is no tangent at the point (3,2) of the graph. Students usually agree that there is no tangent in graphs A and B, but sometimes argue about case C.

Explore 3.1.2 Do you agree that there is no line tangent to any of the graphs in Figure 3.4 at the point (3,2)? ■

Examples of tangents to graphs are shown in Figure 3.5; all the graphs have tangents at the point (2,4). In Figure 3.5C, however, the line shown is not the tangent line. The graphs in B and C are the same and the tangent at (2,4) is the line drawn in B.

A line tangent to the graph of F at a point $(a, F(a))$ contains $(a, F(a))$ so in order to find the tangent we only need to find the slope of the tangent, which we denote by m_a . To find m_a we consider points b in the domain of F that are different from a and compute the slopes,

$$\frac{F(b) - F(a)}{b - a},$$

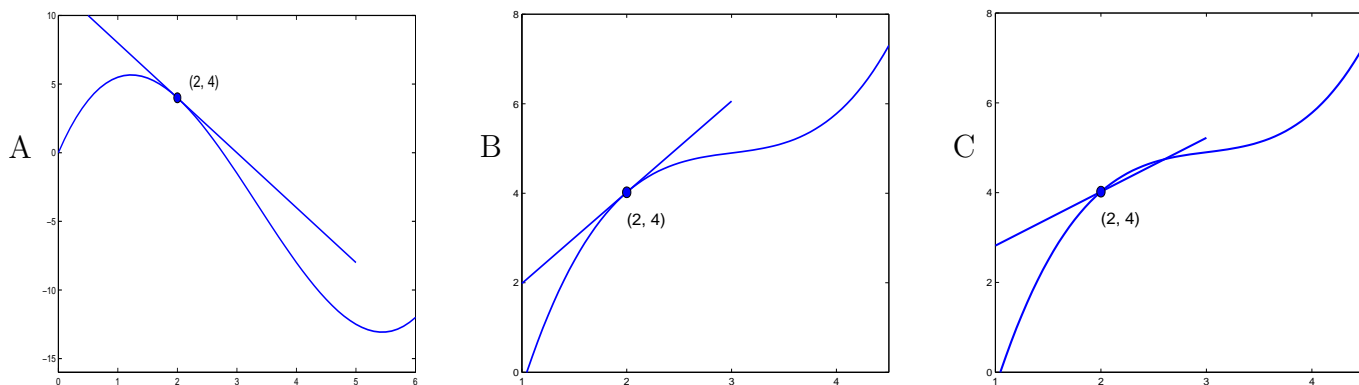

Figure 3.5: All of these graphs have a tangent to the graph at the point $(2, 4)$. However, the line drawn in C is not the tangent.

of the lines that contain $(a, F(a))$ and $(b, F(b))$. The line containing $(a, F(a))$ and $(b, F(b))$ is called a *secant* of the graph of F . The slope, $\frac{F(b) - F(a)}{b - a}$, of the secant is a 'good' approximation to the slope of the tangent when b is 'close to' a . A graph, a tangent to the graph, and a secant to the graph are shown in Figure 3.6. If we could animate that figure, we would slide the point $(b, F(b))$ along the curve towards $(a, F(a))$ and show the secant moving toward the tangent.

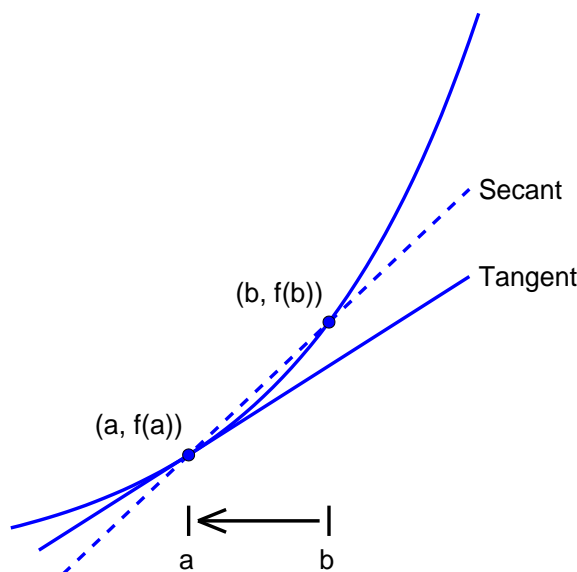

Figure 3.6: A graph, a tangent to the graph, and a secant to the graph.

A substitute for this animation is shown in Figure 3.7. Three points are shown, $B_1, B_2,$ and B_3 with $B_1 = (b_1, F(b_1)), B_2 = (b_2, F(b_2)),$ and $B_3 = (b_3, F(b_3))$. The numbers $b_1, b_2,$ and b_3 are progressively closer to a , and the slopes of the dashed lines from $B_1, B_2,$ and B_3 to $(a, F(a))$ are progressively closer to the slope of the tangent to the graph of F at $(a, F(a))$. Next look at the magnification of F in Figure 3.7B. The progression toward a continues with $b_3, b_4,$ and b_5 , and the slopes from $B_3, B_4,$ and B_5 to $(a, F(a))$ move even closer to the slope of the tangent.

Explore 3.1.3 It is important in Figure 3.7 that as the x-coordinates b_1, b_2, \dots approach a the points $B_1 = (b_1, F(b_1)), B_2 = (b_2, F(b_2)), \dots$ on the curve approach $(a, f(a))$. Would this be true in Figure 3.4B? ■

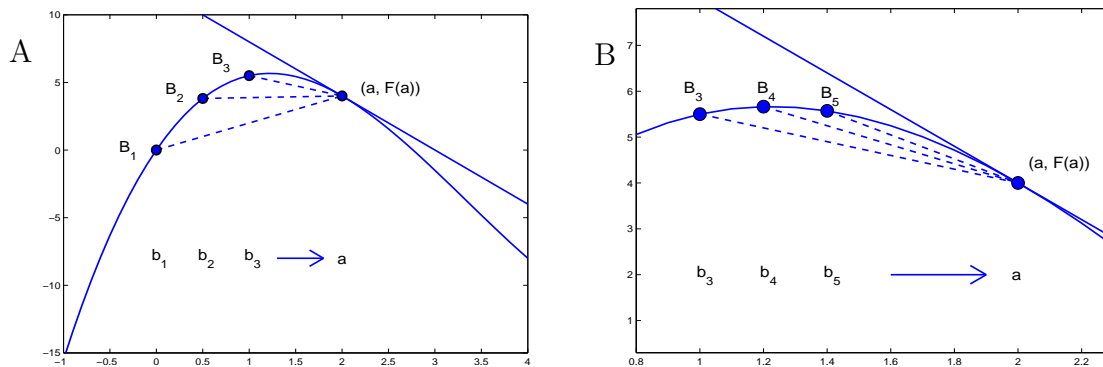

Figure 3.7: A. A graph and tangent to the graph at $(a, F(a))$. Slopes of the secant lines from B_1 , B_2 , and B_3 to $(a, F(a))$ progressively move toward the slope of the tangent. B. A magnification of A with the progression continued.

Definition 3.1.2 Suppose a and b are two numbers and $a < b$. The open interval, (a, b) consists of all of the numbers between a and b (not including either a or b). The closed interval, $[a, b]$ consists of a , all of the numbers between a and b , and b .

The notation for open interval is ambiguous. $(3,5)$ might represent all the numbers between 3 and 5 or might represent the point in the plane whose coordinate pair is $(3,5)$. The context of its use should clarify its meaning.

Definition 3.1.3 Tangent to a graph. Suppose the domain of a function F contains an open interval that contains a number a . Suppose further that there is a number m_a such that that for points b in the interval different from a ,

as b approaches a $\frac{F(b) - F(a)}{b - a}$ approaches m_a .

Then m_a is the slope of the tangent to F at $(a, F(a))$. The graph of $y = F(a) + m_a(x - a)$ is the tangent to the graph of F at $(a, F(a))$.

We are making progress. We now have a definition of tangent to a graph and therefore have given meaning to rate of change of a function. However, we must make sense of the phrase

as b approaches a $\frac{F(b) - F(a)}{b - a}$ approaches m_a .

This phrase is a bridge between geometry and analytical computation and is formally defined in Definition 3.2.1. We first use it on an intuitive basis. Some students prefer an alternate, similarly intuitive statement:

$$\text{if } b \text{ is close to } a \quad \frac{F(b) - F(a)}{b - a} \quad \text{is close to } m_a.$$

Both phrases are helpful.

Consider the parabola, shown in Figure 3.8,

$$F(t) = t^2 \quad \text{for all } t \text{ and a point } (a, a^2) \text{ of } F.$$

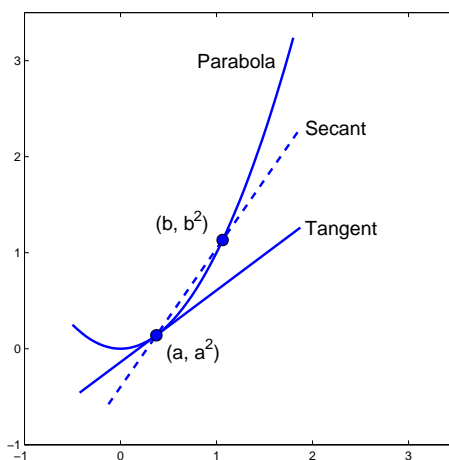

Figure 3.8: The parabola, $F(t) = t^2$, a tangent to the parabola at (a, a^2) , and a secant through (a, a^2) and (b, b^2) .

The slope of the secant is

$$\frac{F(b) - F(a)}{b - a} = \frac{b^2 - a^2}{b - a} = \frac{(b - a)(b + a)}{b - a} = b + a.$$

Although 'approaches' has not been carefully defined, it should not surprise you if we conclude that

$$\text{as } b \text{ approaches } a \quad \frac{F(b) - F(a)}{b - a} = \frac{b^2 - a^2}{b - a} = b + a \quad \text{approaches } a + a = 2a.$$

Alternatively, we might conclude that

$$\text{if } b \text{ is close to } a \quad \frac{F(b) - F(a)}{b - a} = \frac{b^2 - a^2}{b - a} = b + a \quad \text{is close to } a + a = 2a.$$

We make either conclusion, and along with it conclude that the slope of the tangent to the parabola $y = x^2$ at the point (a, a^2) is $2a$. Furthermore, the rate of change of $F(t) = t^2$ at a is $2a$. This is the first of many examples.

Explore 3.1.4 Do this. Use your intuition to answer the following questions. You will not answer g. or h. easily, if at all, but think about it.

- a. As b approaches 4, what number does $3b$ approach?
- b. As b approaches 2, what number does b^2 approach?
- c. If b is close to 5, what number is $3b + b^3$ close to?
- d. As b approaches 0, what number does $\frac{b^2}{b}$ approach?
- e. If b is close to 0, what number is 2^b close to?
- f. As b approaches 0, does $\frac{2^b}{b}$ approach a number?
- g. As b approaches 0, what number does $\frac{\sin b}{b}$ approach? Use radian measure of angles.
- g*. If b is close to 0, what number is $\frac{\sin b}{b}$ close to? Use radian measure of angles.
- h. As b approaches 0, what number does $\frac{2^b-1}{b}$ approach?
- h*. If b is close to 0, what number is $\frac{2^b-1}{b}$ close to?

■

One may look for an answer to c., for example, by choosing a number, b , close to 5 and computing $3b + b^3$. Consider 4.99 which some would consider close to 5. Then $3 \cdot 4.99 + 4.99^3$ is 139.22. 4.99999 is even closer to 5 and $3 \cdot 4.99999 + 4.99999^3$ is 139.99922. One may guess that $3b + b^3$ is close to 140 if b is close to 5. Of course in this case $3b + b^3$ can be evaluated for $b = 5$ and is 140. The approximations seem superfluous.

Explore 3.1.5 Item g* is more interesting than item c because $\frac{\sin b}{b}$ is meaningless for $b = 0$. Compute $\frac{\sin b}{b}$ for $b = 0.1$, $b = 0.01$, and $b = 0.001$ (**put your calculator in radian mode**) and answer the question of g*. ■

Item h is more interesting than g*. Look at the following computations.

$$\begin{array}{l} b = 0.1 \qquad \qquad \frac{2^{0.1} - 1}{0.1} = 0.717734625 \\ b = 0.01 \qquad \qquad \frac{2^{0.01} - 1}{0.01} = 0.69555006 \\ b = 0.001 \qquad \qquad \frac{2^{0.001} - 1}{0.001} = 0.69338746 \\ b = 0.0001 \qquad \qquad \frac{2^{0.00001} - 1}{0.00001} = 0.6931474 \end{array}$$

It is not clear what the numbers on the right are approaching, and, furthermore, the number of digits reported are decreasing. This will be explained when we compute the derivative of the exponential functions in Chapter 5

Explore 3.1.6 Set your calculator to display the maximum number of digits that it will display. Calculate $2^{0.00001}$ and explain why the number of reported digits is decreasing in the previous computations.

Your calculator probably has a button marked 'LN' or 'Ln' or 'ln'. Use that button to compute $\ln 2$ and compare $\ln 2$ with the previous calculations. ■

In the next examples, you will find it useful to recall that for numbers a and b and n a positive integer,

$$b^n - a^n = (b - a) \left(b^{n-1} + b^{n-2}a + b^{n-3}a^2 + \cdots + b^2a^{n-3} + ba^{n-2} + a^{n-1} \right). \quad (3.3)$$

Problem. Find the rate of change of

$$F(t) = 2t^4 - 3t \quad \text{at} \quad t = 2.$$

Equivalently, find the slope of tangent to the graph of F at the point $(2,26)$.

Solution. For b a number different from 2,

$$\begin{aligned} \frac{F(b) - F(2)}{b - 2} &= \frac{(2b^4 - 3b) - (2 \cdot 2^4 - 3 \cdot 2)}{b - 2} \\ &= 2 \frac{b^4 - 2^4}{b - 2} - 3 \frac{b - 2}{b - 2} \\ &= 2 \left(b^3 + b^2 \cdot 2 + b \cdot 2^2 + 2^3 \right) - 3 \end{aligned}$$

We claim that

$$\text{As } b \text{ approaches } 2, \quad \frac{F(b) - F(2)}{b - 2} = 2 \left(b^3 + b^2 \cdot 2 + b \cdot 2^2 + 2^3 \right) - 3 \quad \text{approaches } 61.$$

Therefore, the slope of the tangent to the graph of F at $(2,26)$ is 61, and the rate of change of $F(t) = 2t^4 - 3t$ at $t = 2$ is 61. An equation of the tangent to the graph of F at $(2,26)$ is

$$\frac{y - 26}{t - 2} = 61, \quad y = 61t - 96$$

Graphs of F and $y = 61t - 96$ are shown in Figure 3.9.

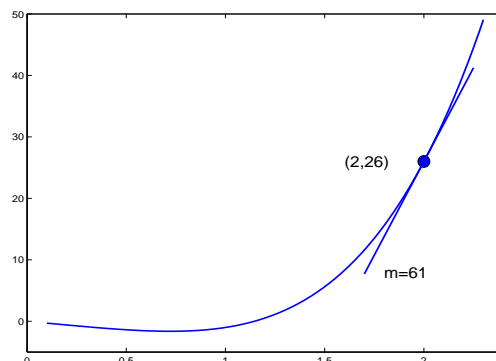

Figure 3.9: Graphs of $F(t) = 2t^4 - 3t$ and the line $y = 61t - 96$.

Problem. Find an equation of the line tangent to the graph of

$$F(t) = \frac{1}{t^2} \quad \text{at the point} \quad (2, 1/4)$$

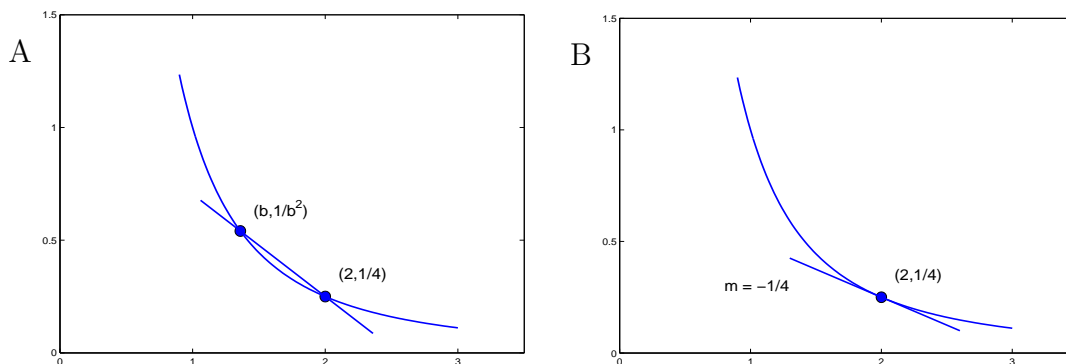

Figure 3.10: A. Graphs of $F(t) = 1/t^2$ and a secant to the graph through $(b, 1/b^2)$ and $(2, 1/4)$. B. Graphs of $F(t) = 1/t^2$ and the line $y = -1/4t + 3/4$.

Solution. Graphs of $F(t) = 1/t^2$ and a secant to the graph through the points $(b, 1/b^2)$ and $(2, 1/4)$ for a number b not equal to 2 are shown in Figure 3.10A.

The slope of the secant is

$$\begin{aligned} \frac{F(b) - F(2)}{b - 2} &= \frac{\frac{1}{b^2} - \frac{1}{2^2}}{b - 2} \\ &= \frac{2^2 - b^2}{b^2 \cdot 2^2} \frac{1}{b - 2} \\ &= -\frac{2 + b}{2^2 \cdot b^2} \quad \text{See Equation 3.3} \end{aligned}$$

We claim that

$$\text{As } b \text{ approaches } 2, \quad \frac{F(b) - F(2)}{b - 2} = -\frac{2 + b}{2^2 \cdot b^2} \quad \text{approaches} \quad -\frac{1}{4}$$

An equation of the line containing $(2, 1/4)$ with slope $-1/4$ is

$$\frac{y - 1/4}{t - 2} = -1/4, \quad y = -\frac{1}{4}t + \frac{3}{4}$$

This is an equation of the line tangent to the graph of $F(t) = 1/t^2$ at the point $(2, 1/4)$. Graphs of F and $y = -1/4t + 3/4$ are shown in Figure 3.10B.

Explore 3.1.7 In Explore Figure 3.1.7 is the graph of $y = \sqrt[3]{x}$. Does the graph have a tangent at $(0, 0)$? **Your vote counts.** ■

Explore Figure 3.1.7 Graph of $y = \sqrt[3]{x}$.

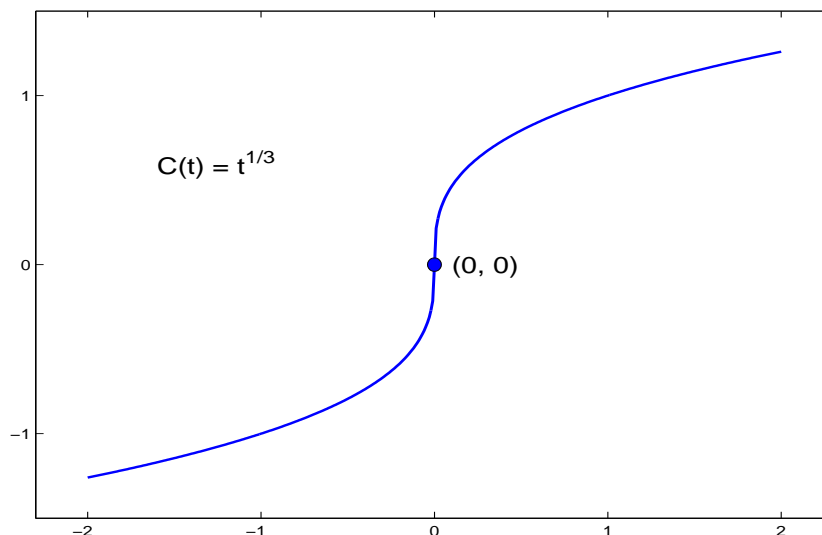

Problem. At what rate is the function $F(t) = \sqrt[3]{t}$ increasing at $t = 8$?

Solution. For a number b not equal to 8,

$$\begin{aligned} \frac{F(b) - F(8)}{b - 8} &= \frac{\sqrt[3]{b} - \sqrt[3]{8}}{b - 8} \\ &= \frac{\sqrt[3]{b} - 2}{(\sqrt[3]{b})^3 - 2^3} && \text{Lightning Bolt! See Figure 3.11} \\ &= \frac{1}{(\sqrt[3]{b})^2 + \sqrt[3]{b} \cdot 2 + 2^2} \end{aligned}$$

Now we claim that

$$\text{as } b \text{ approaches } 8 \quad \frac{F(b) - F(8)}{b - 8} = \frac{1}{(\sqrt[3]{b})^2 + \sqrt[3]{b} \cdot 2 + 2^2} \quad \text{approaches } \frac{1}{12}.$$

Therefore, the rate of increase of $F(t) = \sqrt[3]{t}$ at $t = 8$ is $1/12$. A graph of $F(t) = \sqrt[3]{t}$ and $y = t/12 + 4/3$ is shown in Figure 3.12.

Pattern. In each of the computations that we have shown, we began with an expression for

$$\frac{F(b) - F(a)}{b - a}$$

that was meaningless for $b = a$ because of $b - a$ in the denominator. We made some algebraic rearrangement that neutralized the factor $b - a$ in the denominator and obtained an expression $E(b)$ such that

1. $\frac{F(b) - F(a)}{b - a} = E(b)$ for $b \neq a$, and
2. $E(a)$ is defined, and
3. As b approaches a , $E(b)$ approaches $E(a)$.

A **Lightning Bolt** signals a step that is a surprise, mysterious, obscure, or of doubtful validity, or to be proved in later chapters. Think of Zeus atop Mount Olympus issuing thunderous proclamations amid darkness and lightning.



Figure 3.11: Figure of Zeus from <http://en.wikipedia.org/wiki/Zeus>. Picture is by Sdwelch1031

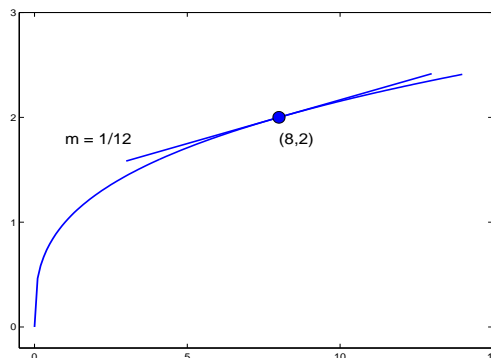

Figure 3.12: Graphs of $F(t) = \sqrt[3]{t}$ and the line $y = t/12 + 4/3$.

We then claimed that

$$\text{as } b \text{ approaches } a \quad \frac{F(b) - F(a)}{b - a} \quad \text{approaches} \quad E(a).$$

This pattern will serve you well until we consider exponential, logarithmic and trigonometric functions where more than algebraic rearrangement is required to neutralize the factor $b - a$ in the denominator. Item 3 of this list is often given scant attention, but deserves your consideration.

Exercises for Section 3.1, Tangent to the graph of a function.

Exercise 3.1.1 Approximate the growth rate of the *V. natriegens* population of Table 1.1 at time $t = 56$ minutes.

Exercise 3.1.2 Approximate the growth rate of $B(T) = 0.022$ at time a. $T = 56$ minutes, b. $T = 30$ minutes, c. $T = 0$ minutes.

Exercise 3.1.3 Shown in Exercise Figure 3.1.3 is the ventricular volume of the heart during a normal heart beat of 0.8 seconds. During systole the ventricle contracts and pushes the blood into the aorta. Find approximately the flow rate in ml/sec of blood in the aorta at time $t = 0.2$ seconds. Find approximately the maximum flow rate of blood in the aorta.

Figure for Exercise 3.1.3 Graph of the ventricular volume during a normal heart beat. Patterned after the graph in Figure 9.13.

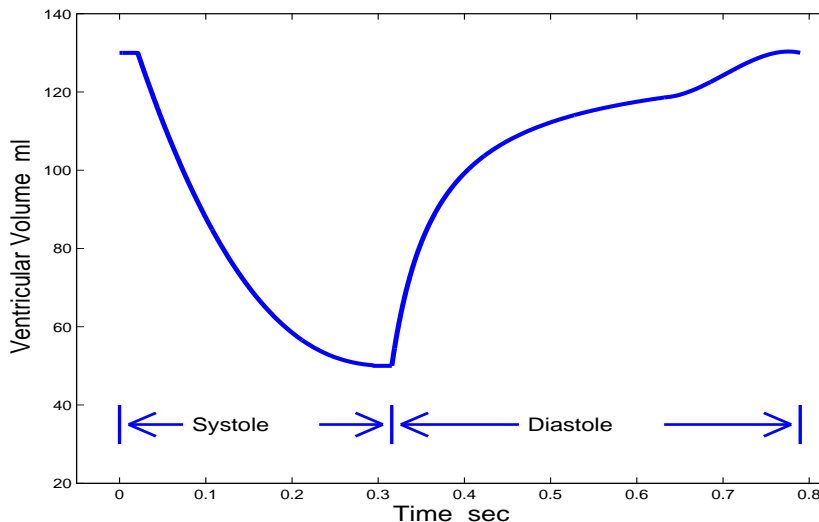

Exercise 3.1.4 Shown in Exercise Figure 3.1.4 is a graph of air densities in Kg/m^3 as a function of altitude in meters (U.S. Standard Atmospheres 1976, National Oceanic and Atmospheric Administration, NASA, U.S. Air Force, Washington, D.C. October 1976). You will find the rate of change of density with altitude. Because the independent variable is altitude, a distance, the rate of change is commonly called the *gradient*.

- At what rate is air density changing with increase of altitude at altitude = 2000 meters? Alternatively, what is the gradient of air density at 2000 meters?
- What is the gradient of air density at altitude = 5000 meters?
- What is the gradient of air density at altitude = 8000 meters?

Figure for Exercise 3.1.4 Graph of air density (Kg/m^3) vs altitude (m).

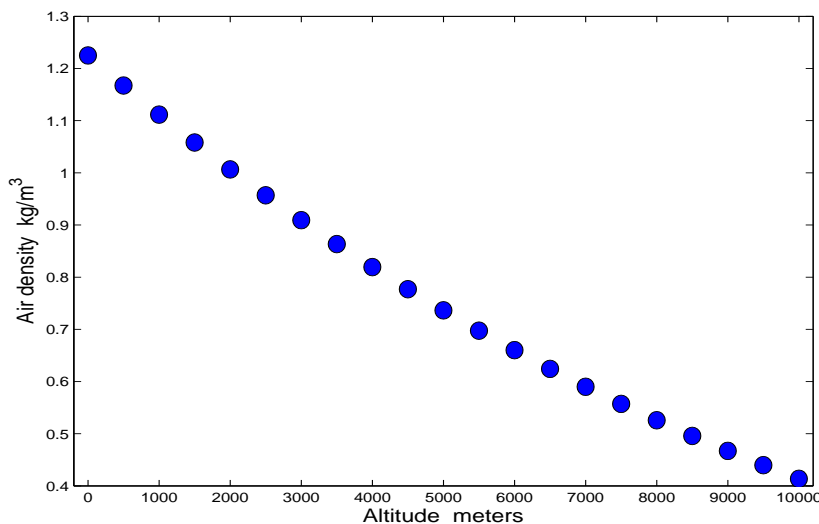

Exercise 3.1.5 An African honey bee *Apis mellifera scutellata* was introduced into Brazil in 1956 by geneticists who hoped to increase honey production with a cross between the African bee which was native to the tropics and the European species commonly used by bee keepers in South America and in the United States. Twenty six African queens escaped into the wild in 1957 and the subsequent feral population has been very aggressive and has disrupted or eliminated commercial honey production in areas where they have spread.

Shown in Exercise Figure 3.1.5 is a map ¹ that shows the regions occupied by the African bee in the years 1957 to 1983, and projections of regions that would be occupied by the bees during 1985-1995.

- a. At what rate did the bees advance during 1957 to 1966?
- b. At what rate did the bees advance during 1971 to 1975?
- c. At what rate did the bees advance during 1980 to 1982?
- d. At what rate was it assumed the bees would advance during 1983 - 1987?

Figure for Exercise 3.1.5 The spread of the African bee from Brazil towards North America. The solid curves with dates represent observed spread. The dashed curves and dates are projections of spread.

¹Orley R. Taylor, African bees: potential impact in the United States, *Bull Ent Soc of America*, Winter, 1985, 15-24. Copyright,1985, The Entomological Society of America.

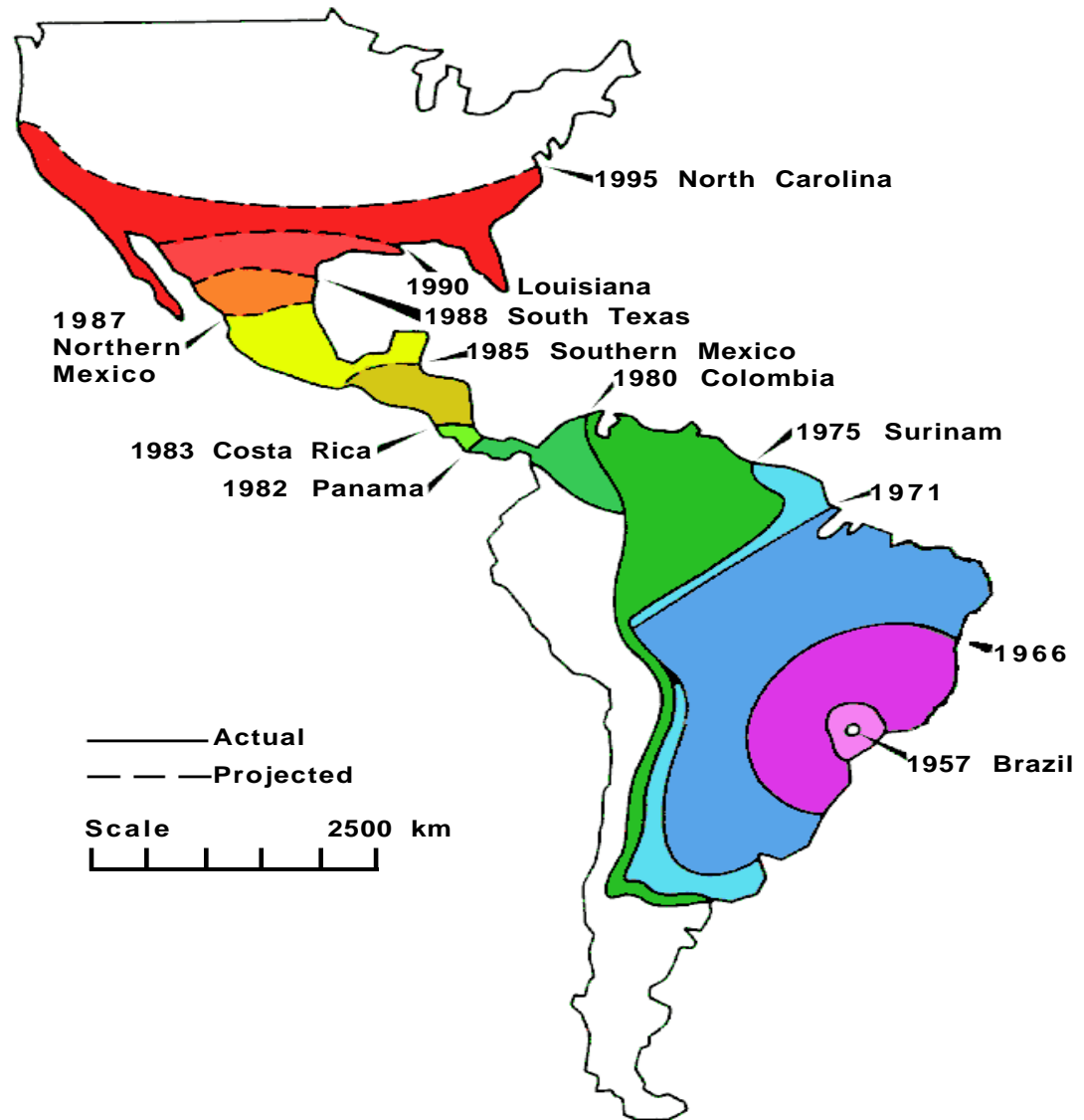

Exercise 3.1.6 If b approaches 3

- b approaches _____.
- $2 \div b$ approaches _____. Note: Neither 0.6666 nor 0.6667 is the answer.
- π approaches _____.
- $\frac{2}{\sqrt{b+\sqrt{3}}}$ approaches _____. Note: Neither 0.577 nor 0.57735026919 is the answer.
- $b^3 + b^2 + b$ approaches _____.
- $\frac{b}{1+b}$ approaches _____.
- 2^b approaches _____.
- $\log_3 b$ approaches _____.

Exercise 3.1.7 In a classic study², David Ho and colleagues treated HIV-1 infected patients with ABT-538, an inhibitor of HIV-1 protease. HIV-1 protease is an enzyme required for viral

²David D. Ho, Avidan U Neumann, Alan S. Perlson, Wen Chen, John M. Leonard, & Martin Markowitz, Rapid turnover of plasma virions and CD4 lymphocytes in HIV-1 infection, *Nature* 373, 123-126, (1995)

replication so that the inhibitor disrupted HIV viral reproduction. Viral RNA is a measure of the amount of virus in the serum. Data showing the amount of viral RNA present in serum during two weeks following drug administration are shown in Table Ex. 3.1.7 for one of the patients. Before treatment the patient's serum viral RNA was roughly constant at 180,000 copies/ml. On day 1 of the treatment, viral production was effectively eliminated and no new virus was produced for about 21 days after which a viral mutant that was resistant to ABT-538 arose. The rate at which viral RNA decreased on day 1 of the treatment is a measure of how rapidly the patient's immune system eliminated the virus before treatment.

- Compute an estimate of the rate at which viral RNA decreased on day 1 of the treatment.
- Assume that the patient's immune system cleared virus at that same rate before treatment. What percent of the virus present in the patient was destroyed by the patient's immune system each day before treatment?
- At what rate did the virus reproduce in the absence of ABT-538.

Table for Exercise 3.1.7 RNA copies/ml in a patient during treatment with an inhibitor of HIV-1 protease.

Observed	
Time Days	RNA copies/ml Thousands
1	80
4	50
8	18
11	9.5
15	5

Exercise 3.1.8 Shown in Figure Ex. 3.1.8 is the graph of the line, $y = 0.5x$, and the point $(2,1)$.

- Is there a tangent to the graph of $y = 0.5x$ at the point $(2,1)$?
- Suppose $H(t) = 0.5t$ is the height in feet of water above flood stage in a river t hours after midnight. At what rate is the water rising at time $t = 2$ am?

Figure for Exercise 3.1.8 Graph of the line $y = 0.5x$. See Exercise 3.1.8.

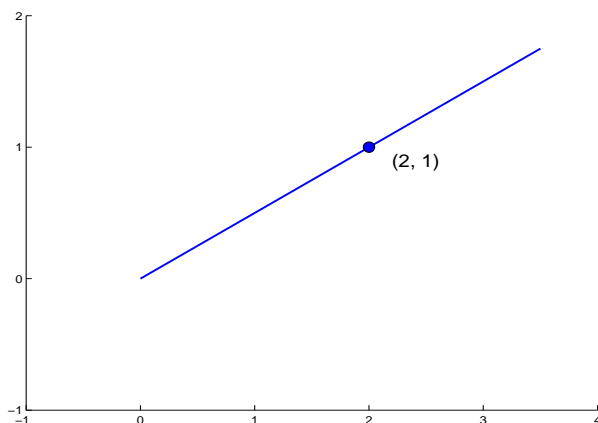

Exercise 3.1.9 See Figure Ex. 3.1.9. Let A be the point $(3,4)$ of the circle

$$x^2 + y^2 = 25$$

Let B be a point of the circle different from A . What number does the slope of the line containing A and B approach as B approaches A ?

Figure for Exercise 3.1.9 Graph of the circle $x^2 + y^2 = 25$ and a secant through $(3,4)$ and a point B . See Exercise 3.1.9.

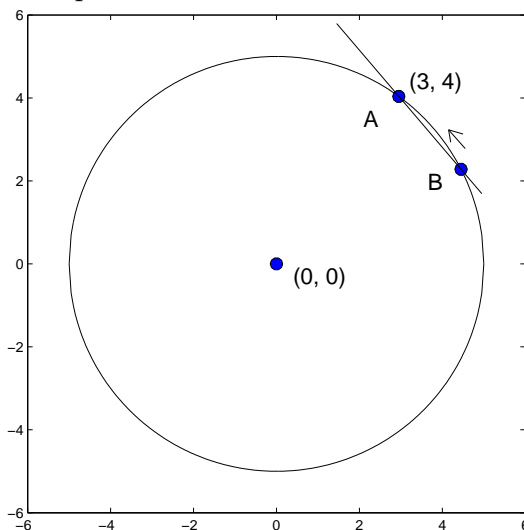

Exercise 3.1.10 Technology. Suppose plasma penicillin concentration in a patient following injection of 1 gram of penicillin is observed to be

$$P(t) = 200 2^{-0.03t},$$

where t is time in minutes and $P(t)$ is $\mu\text{g/ml}$ of penicillin. Use the following steps to approximate the rate at which the penicillin level is changing at time $t = 5$ minutes and at $t = 0$ minutes.

- t = 5 minutes.** Draw the graph of $P(t)$ vs t for $4.9 \leq t \leq 5.1$. (The graph should appear to be a straight line on this short interval.)
- Complete the table on the left, computing the average rates of change of penicillin level.

b	$\frac{P(b)-P(5)}{b-5}$	b	$\frac{P(b)-P(0)}{b-0}$
4.9	-3.7521	-0.1	OMIT
4.95		-0.05	OMIT
4.99		-0.01	OMIT
4.995		-0.005	OMIT
5.005		0.005	
5.01		0.01	
5.05		0.05	
5.1	-3.744	0.1	-4.155

- c. What is your best estimate of the rate of change of penicillin level at the time $t = 5$ minutes? Include units in your answer.
- d. **$t = 0$ minutes.** Complete the second table above. The OMIT entries in the second table refer to the fact that the level of penicillin, $P(t)$, may not be given by the formula for negative values of time, t . What is your best estimate of the rate of change of penicillin level at the time $t = 0$ minutes?

Exercise 3.1.11 The patient in Exercise 3.1.10 had penicillin level $200 \mu\text{g}/\text{ml}$ at time $t = 0$ following a 1 gram injection. What is the approximate volume of the patient's vascular pool? If you wished to maintain the patient's penicillin level at $200 \mu\text{g}/\text{ml}$, at what rate would you continuously infuse the patient with penicillin?

Exercise 3.1.12 Find equations of the lines tangent to the graphs of the function F at the indicated points.

- | | |
|-------------------------------------|--------------------------------------|
| a. $F(t) = t^2$ at $(2, 4)$ | b. $F(t) = t^2 + 2$ at $(2, 6)$ |
| c. $F(t) = t + 1$ at $(2, 3)$ | d. $F(t) = 3t^3 - 4t^2$ at $(1, -1)$ |
| e. $F(t) = 1/(t + 1)$ at $(1, 1/2)$ | f. $F(t) = \sqrt[4]{t}$ at $(1, 1)$ |

Exercise 3.1.13 Find the rates of change of the function F at the indicated points.

- | | |
|-------------------------------------|-----------------------------------|
| a. $F(t) = t^3$ at $(2, 8)$ | b. $F(t) = 1/t$ at $(2, 1/2)$ |
| c. $F(t) = 2t + t^2$ at $(2, 8)$ | d. $F(t) = \sqrt{t}$ at $(4, 2)$ |
| e. $F(t) = t/(t + 1)$ at $(1, 1/2)$ | f. $F(t) = (t + 1)/t$ at $(1, 2)$ |

Exercise 3.1.14 In Figure Ex. 3.1.14 is the graph of a parabola with vertex at A and a secant to the parabola through A and a point B . What number does the slope of the line containing A and B approach as B approaches A ?

Figure for Exercise 3.1.14 A parabola with vertex at A and a secant through A and a point B . See Exercise 3.1.14.

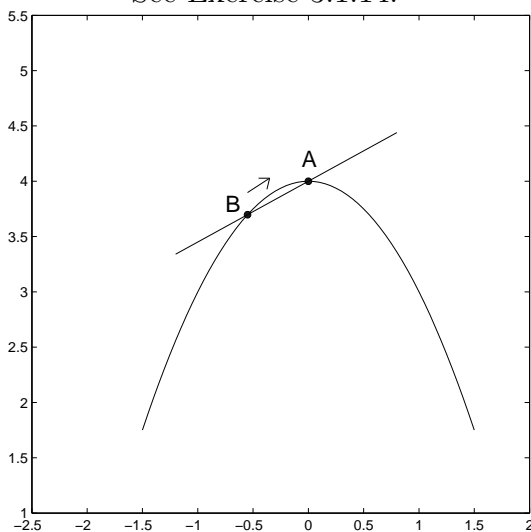

3.2 Limit and rate of change as a limit

The phrase

$$\text{as } b \text{ approaches } a \quad \frac{F(b) - F(a)}{b - a} \quad \text{approaches } m_a \quad (3.4)$$

introduced in the previous section to define slope of a tangent to the graph of F at a point $(a, F(a))$ can be made more explicit. Almost 200 years after Isaac Newton and Gottfried Leibniz introduced calculus (about 1665), Karl Weierstrass introduced (about 1850) a concise statement of **limit** that clarifies the phrase. Phrase 3.4 would be rewritten

$$\text{The limit as } b \text{ approaches } a \text{ of } \frac{F(b) - F(a)}{b - a} \text{ is } m_a. \quad (3.5)$$

We introduce notation separate from that of the phrase 3.4 because 'limit' has application well beyond its use in defining tangents.

Definition 3.2.1 Definition of limit. Suppose G is a function, a is a number, and every open interval that contains a contains a point of the domain of G distinct from a . Also suppose L is a number.

The statement that

$$\text{as } x \text{ approaches } a \quad G(x) \text{ approaches } L$$

means that if ϵ is a positive number, there is a positive number δ such that if x is in the domain of G and $0 < |x - a| < \delta$ then $|G(x) - L| < \epsilon$.

This relation is denoted by

$$\lim_{x \rightarrow a} G(x) = L \quad (3.6)$$

and is read, 'The limit as x approaches a of $G(x)$ is L .'

The statement that ' $\lim_{x \rightarrow a} G(x)$ exists' means that G is a function, a is a number, and every open interval that contains a contains a number in the domain of G distinct from a , and for some number L , $\lim_{x \rightarrow a} G(x) = L$.

The use of the word 'limit' in Definition 3.2.1 is different from its usual use as a bound, as in 'speed limit' or in "1. the point, line or edge where something ends or must end; \dots " (Webster's new College Dictionary, Fourth Edition). Perhaps 'goal' (something aimed at or striven for) would be a better word, but we and you have no choice: assume a new and well defined meaning for 'limit.'

Important. In Definition 3.2.1, the question of whether $G(a)$ is defined is irrelevant, and if $G(a)$ is defined, the value of $G(a)$ is irrelevant. The inequality $0 < |x - a| < \delta$ specifically excludes consideration of $x = a$. Two illustrative examples appear in Figure 3.13. They are the graphs of F_1 and F_2 , defined by

$$F_1(x) = \begin{cases} \frac{1}{2} * x & \text{for } x \neq 1 \\ \text{not defined} & \text{for } x = 1 \end{cases} \quad F_2(x) = \begin{cases} \frac{1}{2}x & \text{for } x \neq 1 \\ 1 & \text{for } x = 1 \end{cases} \quad (3.7)$$

Intuitively: If x is close to 1 and different from 1, $F_1(x) = \frac{1}{2}x$ is close to 0.5 and $F_2(x)$ is close to

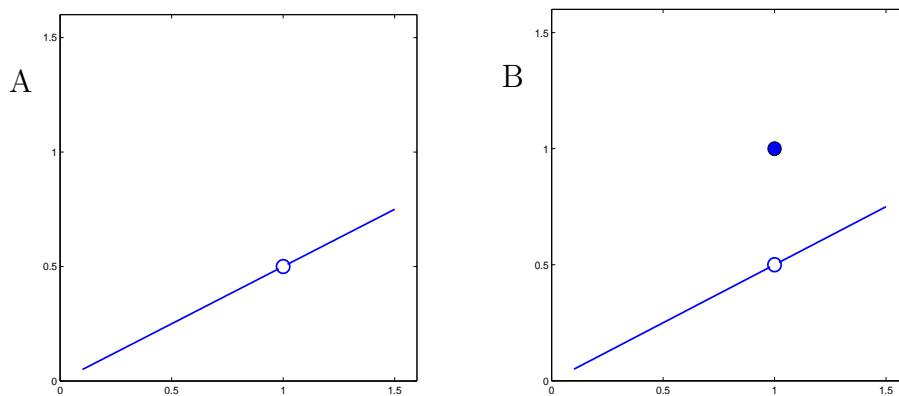

Figure 3.13: A. Graphs of F_1 and F_2 as defined in Equation 3.7.

0.5.

$$\lim_{x \rightarrow 1} F_1(x) = 0.5, \quad \text{and} \quad \lim_{x \rightarrow 1} F_2(x) = 0.5$$

By Definition 3.2.1: Suppose ϵ is a positive number; choose $\delta = \epsilon$.

$$\begin{aligned} &\text{If } x \text{ is in the domain of } F_1 \text{ and } 0 < |x - 1| < \delta, \\ &\text{then } \left| F_1(x) - \frac{1}{2} \right| = \left| \frac{1}{2}x - \frac{1}{2} \right| = \frac{1}{2}|x - 1| < \frac{1}{2}\delta < \epsilon. \end{aligned}$$

The same argument applies to F_2 . That $F_2(1) = 1$ does not change the argument because $0 < |x - 1| < \delta$ excludes $x = 1$.

Example 3.2.1 Practice with ϵ 's and δ 's.

1. Suppose administration of $a = 3.5$ mg of growth hormone produces the optimum serum hormone level $L = 8.3 \mu\text{g}$ in a 24 kg boy. Suppose further that an amount x mg of growth hormone produces serum hormone level $G(x) \mu\text{g}$. You may wish to require $\epsilon = 0.25 \mu\text{g}$ accuracy in serum hormone levels, and need to know what specification δ mg accuracy to require in preparation of the growth hormone to be administered. That is, if the actual amount administered is between $3.5 - \delta$ mg and $3.5 + \delta$ mg then the resulting serum hormone level will be between $8.3 - 0.25 = 8.05 \mu\text{g}$ and $8.3 + 0.15 = 8.45 \mu\text{g}$. If instead of $\epsilon = 0.25 \mu\text{g}$, your tolerance is $\epsilon = 0.05 \mu\text{g}$, the specified δ mg would be smaller.

2. Show that if a is a positive number, then

$$\lim_{x \rightarrow a} \sqrt{x} = \sqrt{a} \tag{3.8}$$

Suppose $\epsilon > 0$. Let $\delta = \epsilon \sqrt{a}$. Suppose x is in the domain of \sqrt{x} and $0 < |x - a| < \delta$. Then

$$|\sqrt{x} - \sqrt{a}| \stackrel{(i)}{=} \frac{|x - a|}{\sqrt{x} + \sqrt{a}} \stackrel{(ii)}{\leq} \frac{|x - a|}{\sqrt{a}} \stackrel{(iii)}{<} \frac{\delta}{\sqrt{a}} \stackrel{(iv)}{=} \frac{\epsilon \sqrt{a}}{\sqrt{a}} \stackrel{(v)}{=} \epsilon.$$

Explore 3.2.1 Our choice of $\delta = \epsilon \sqrt{a}$ is a bit of a **fortuitous lightning bolt**³, Step (i) is an algebraic trick, you may well wonder why Step (ii) is even correct or not strictly $<$, you may wonder where δ came from in Step (iii), the fortuitous lightning bolt is the reason for Step (iv) and explains why we chose $\delta = \epsilon \sqrt{a}$, but by this time you may even doubt Step (v). You would be wise to check each step. ■

³Actually found by working the problem backwards. What must δ be in order to insure step (iv) will be correct?

3. Find a number $\delta > 0$ so that

$$\text{if } 0 < |x - 1| < \delta \quad \text{then} \quad \left| \frac{1}{1 + x^2} - 0.5 \right| < 0.01.$$

A graph of $y = 1/(1 + x^2)$ is shown in Figure 3.14 along with lines a distance 0.01 above and below $y = 0.5$. We solve for x at the intersections of the lines with the graph.

$$\frac{1}{1 + x^2} = 0.49, \quad x = 1.0202; \quad \text{and} \quad \frac{1}{1 + x^2} = 0.51, \quad x = 0.98019.$$

From the graph it is clear that

$$\text{if } 0.981 < x < 1.02 \quad \text{then} \quad 0.49 < \frac{1}{1 + x^2} < 0.51.$$

We choose $\delta = 0.019$, the smaller of $1.0 - 0.981$ and $1.02 - 1.0$.

$$\text{Then if } 0 < |x - 1| < \delta, \quad \left| \frac{1}{1 + x^2} - 0.5 \right| < 0.01.$$

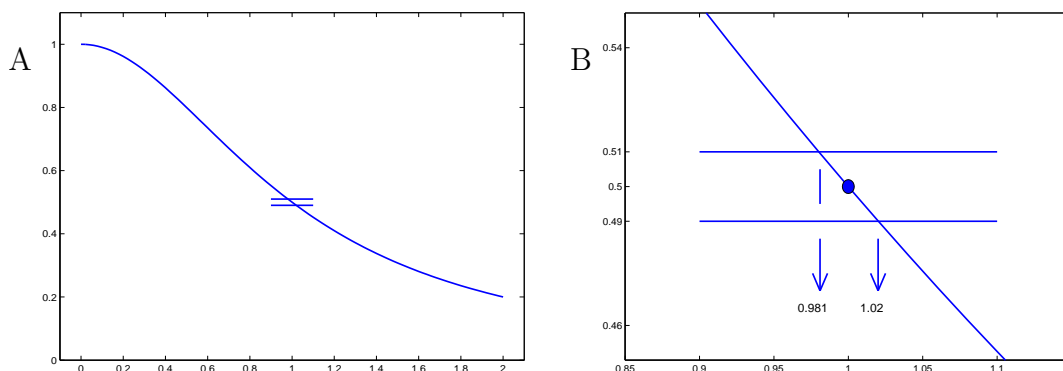

Figure 3.14: A. Graph of $F(x) = 1/(1 + x^2)$, and B a magnification of A. In both graphs, segments of the lines $y = 0.49$ and $y = 0.51$ are drawn.

4. Find a number $\delta > 0$ so that

$$\text{if } 0 < |x - 4| < \delta \quad \text{then} \quad \left| \frac{\frac{1}{\sqrt{x}} - \frac{1}{2}}{x - 4} + \frac{1}{16} \right| < 0.01.$$

This algebraic challenge springs from the problem of showing that the slope of

$$f(x) = \frac{1}{\sqrt{x}} \quad \text{at the point} \quad \left(4, \frac{1}{2}\right) \quad \text{is} \quad \frac{-1}{16}.$$

We first do some algebra.

$$\frac{\frac{1}{\sqrt{x}} - \frac{1}{2}}{x - 4} + \frac{1}{16} = \frac{\frac{2 - \sqrt{x}}{2\sqrt{x}}}{(\sqrt{x} - 2)(\sqrt{x} + 2)} + \frac{1}{16} = \frac{-1}{2\sqrt{x}(\sqrt{x} + 2)} + \frac{1}{16} = \frac{-8 + \sqrt{x}(\sqrt{x} + 2)}{16\sqrt{x}(\sqrt{x} + 2)}$$

It is sufficient to find $\delta > 0$ so that

$$\text{if } 0 < |x - 4| < \delta \quad \text{then} \quad \left| \frac{-8 + \sqrt{x}(\sqrt{x} + 2)}{16\sqrt{x}(\sqrt{x} + 2)} \right| < 0.01 \quad \text{or} \quad \left| \frac{-8 + \sqrt{x}(\sqrt{x} + 2)}{\sqrt{x}(\sqrt{x} + 2)} \right| < 0.16$$

Assume that x is 'close to' 4 and certainly bigger than 1 so that the denominator, $\sqrt{x}(\sqrt{x} + 2)$ is greater than 1. Then it is sufficient to find $\delta > 0$ so that

$$\left| -8 + \sqrt{x}(\sqrt{x} + 2) \right| = \left| -8 + x + 2\sqrt{x} \right| < 0.16.$$

Let $z = \sqrt{x}$ so that $z^2 = x$ and solve

$$-8 + z^2 + 2z = -0.16 \quad \text{and} \quad -8 + z^2 + 2z = 0.16$$

$$z_1 = 1.97321 \qquad z_2 = 2.026551.97321$$

$$x_1 = 3.89356 \qquad x_2 = 4.10690$$

We will choose $\delta = 0.1$ so that

$$\text{if } 0 < |x - 4| < 0.1 \quad \text{then } x \text{ is between } x_1 \text{ and } x_2 \text{ and} \quad \left| \frac{\frac{1}{\sqrt{x}} - \frac{1}{2}}{x - 4} + \frac{1}{16} \right| < 0.01.$$

5. Suppose you try to 'square the circle.' That is, suppose you try to construct a square the area of which is exactly the area, π , of a circle of radius 1. A famous problem from antiquity is whether one can construct such a square using only a straight edge and a compass. The answer is no. But can you get close?

Suppose you will be satisfied if the area of your square is within 0.01 of π (think, $\epsilon = 0.01$). It helps to know that

$$\pi = 3.14159265\dots, \quad \text{and} \quad 1.77^2 = 3.1329,$$

and that every interval of rational length (for example, 1.77) can be constructed with straight edge and compass. Because $1.77^2 = 3.1329$ is within 0.01 of π , you can 'almost' square the circle with straight edge and compass.

Explore 3.2.2 Suppose you are only satisfied if the area of your square is within 0.001 of π . What length should the edges of your square be in order to achieve that accuracy? ■

Now suppose ϵ is a positive number and ask, how close (think, δ) must your edge be to $\sqrt{\pi}$ in order to insure that

$$|\text{the area of your square} - \pi| < \epsilon \quad ?$$

Let x be the length of the side of your square. Your problem is to find δ so that

$$\text{if } |x - \sqrt{\pi}| < \delta, \quad \text{then } |x^2 - \pi| < \epsilon.$$

Danger: This may fry your brain. Look at the target $|x^2 - \pi| < \epsilon$ and write

$$|x^2 - \pi| < \epsilon$$

$$|x - \sqrt{\pi}| |x + \sqrt{\pi}| < \epsilon$$

Lets require first of all that $0 < x < 5$. (We get to write the specifications for x .) Then $x + \sqrt{\pi} < 10$. (Actually, $\sqrt{\pi} \doteq 1.7725$ so that $x + \sqrt{\pi}$ is less than 7, but we can be generous.) Now look at our target,

$$|x^2 - \pi| = |x - \sqrt{\pi}| |x + \sqrt{\pi}| < \epsilon$$

Choose δ : Insist that $|x - \sqrt{\pi}| < \delta = \text{Minimum}(\epsilon/10, 1)$. Then $0 < x < 5$, and

$$|x^2 - \pi| = |x - \sqrt{\pi}| |x + \sqrt{\pi}| < \frac{\epsilon}{10} \cdot 10 = \epsilon.$$

If $|x - \sqrt{\pi}| < \delta = \text{Minimum}(\epsilon/10, 1)$, then $|x^2 - \pi| < \epsilon$.

Explore 3.2.3 We required that $0 < x < 5$. (We get to write the specifications for x .) Would it work to require that $0 < x < 1$? ■

Using the definition of limit we rewrite the definitions of tangent to the graph of a function and the rate of change of a function.

Definition 3.2.2 Definition of tangent and rate of change, revisited.

Suppose F is a function, a is a number in the domain of F , and every open interval that contains a contains a point of the domain of F distinct from a , and m_a is a number. The statement that the slope of the tangent to the graph of F at $(a, F(a))$ is m_a and that the rate of change of F at a is m_a means that

$$\lim_{b \rightarrow a} \frac{F(b) - F(a)}{b - a} = m_a. \quad (3.9)$$

In the previous section we found that the slope of the tangent to the graph of $F(t) = t^2$ at a point (a, a^2) was $2a$. Using the limit notation we would write that development as

$$\begin{aligned} \lim_{b \rightarrow a} \frac{F(b) - F(a)}{b - a} &= \lim_{b \rightarrow a} \frac{b^2 - a^2}{b - a} \\ &= \lim_{b \rightarrow a} \frac{(b - a)(b + a)}{b - a} \\ &= \lim_{b \rightarrow a} (b + a) \\ &= a + a = 2a \end{aligned}$$

There is some algebra of the limit symbol, $\lim_{x \rightarrow a}$, that is important. Suppose each of F_1 and F_2 is a function and a is a number and $\lim_{x \rightarrow a} F_1(x)$ and $\lim_{x \rightarrow a} F_2(x)$ both exist. Suppose further that C is a number. Then

$$\lim_{x \rightarrow a} C = C \quad (3.10)$$

$$\lim_{x \rightarrow a} x = a \quad (3.11)$$

$$\text{If } a \neq 0, \text{ then } \lim_{x \rightarrow a} \frac{1}{x} = \frac{1}{a} \quad (3.12)$$

$$\lim_{x \rightarrow a} C F_1(x) = C \lim_{x \rightarrow a} F_1(x) \quad (3.13)$$

$$\lim_{x \rightarrow a} (F_1(x) + F_2(x)) = \lim_{x \rightarrow a} F_1(x) + \lim_{x \rightarrow a} F_2(x) \quad (3.14)$$

$$\lim_{x \rightarrow a} (F_1(x) \times F_2(x)) = \left(\lim_{x \rightarrow a} F_1(x) \right) \times \left(\lim_{x \rightarrow a} F_2(x) \right) \quad (3.15)$$

Probably all of these equations are sufficiently intuitive that proofs of them seem superfluous. Equations 3.10 and 3.11 could be more accurately expressed. For Equation 3.10 one might say,

$$\text{"If } F_1(x) = C \text{ for all } x \neq a \text{ then } \lim_{x \rightarrow a} F_1(x) = C." \quad (3.16)$$

Explore 3.2.4 Suppose F_1 is defined by

$$F_1(x) = C \quad \text{if } x \neq a$$

$$F_1(a) = C + 1$$

Is it true that

$$\lim_{x \rightarrow a} F_1(x) = C \quad ?$$

■

Explore 3.2.5 Write a more accurate expression for Equation 3.11 similar to the more accurate expression 3.16 for 3.10. ■

Proof of Equations 3.12, 3.13 and 3.14 are rather easy and are included to illustrate the process.

Proof of Equation 3.12. Suppose $a \neq 0$ and $\epsilon > 0$. Let

$$\delta = \text{Minimum}(|a|/2, \epsilon a^2/2). \quad \text{Suppose } 0 < |x - a| < \delta.$$

Note: Because $|x - a| < \delta \leq |a|/2$, $|x| > |a|/2$ and $|x a| > |a^2|/2$.

$$\begin{aligned} \text{Then } \left| \frac{1}{x} - \frac{1}{a} \right| &= \left| \frac{x - a}{x a} \right| \\ &< \frac{\delta}{|x a|} \\ &< \frac{\delta}{a^2/2} \\ &\leq \frac{\epsilon a^2/2}{a^2/2} = \epsilon \end{aligned}$$

Proof of Equation 3.13. Let $\lim_{x \rightarrow a} F_1(x) = L_1$. Suppose ϵ is a positive number.

Case $C = 0$. Let $\delta = 1$. Then if x is in the domain of F_1 and $0 < |x - a| < \delta$,

$$|C F_1(x) - C L_1| = |0 - 0| = 0 < \epsilon.$$

Case $C \neq 0$. Let

$$\epsilon_0 = \frac{\epsilon}{|C|}$$

Because $\lim_{x \rightarrow a} F_1(x) = L_1$, there is $\delta > 0$ such that if $0 < |x - a| < \delta$ then $|F_1(x) - L_1| < \epsilon_0$. Then if x is in the domain of F and $0 < |x - a| < \delta$,

$$|C F_1(x) - C L_1| = |C| |F_1(x) - L_1| < |C| \epsilon_0 = |C| \frac{\epsilon}{|C|} = \epsilon.$$

Thus

$$\lim_{x \rightarrow a} C F_1(x) = C L_1 = C \lim_{x \rightarrow a} F_1(x)$$

Proof of Equation 3.14. Suppose $\lim_{x \rightarrow a} F_1(x) = L_1$ and $\lim_{x \rightarrow a} F_2(x) = L_2$. Suppose $\epsilon > 0$. There are numbers δ_1 and δ_2 such that

$$\text{if } 0 < |x - a| < \delta_1 \text{ then } |F_1(x) - L_1| < \frac{\epsilon}{2} \quad \text{and} \quad \text{if } 0 < |x - a| < \delta_2 \text{ then } |F_2(x) - L_2| < \frac{\epsilon}{2}$$

Let $\delta = \text{Minimum}(\delta_1, \delta_2)$. Suppose $0 < |x - a| < \delta$. Then

$$\begin{aligned} |F_1(x) + F_2(x) - (L_1 + L_2)| &\leq |F_1(x) - L_1| + |F_2(x) - L_2| \\ &< \frac{\epsilon}{2} + \frac{\epsilon}{2} = \epsilon \end{aligned}$$

Honest Exposition. Almost always in evaluating

$$\lim_{x \rightarrow a} F(x),$$

if F is a familiar function and $F(a)$ is defined then

$$\lim_{x \rightarrow a} F(x) = F(a).$$

If this happens, F is said to be *continuous* at a (more about continuity later). It follows from Equations 3.10 through 3.15, for example, that

$$\text{if } P(x) \text{ is any polynomial, then } \lim_{x \rightarrow a} P(x) = P(a). \quad \text{See Exercise 3.2.7.}$$

Moreover, even if $F(a)$ is not meaningful but there is an expression $E(x)$ for which

$$F(x) = E(x) \quad \text{for } x \neq a, \quad \text{and } E(a) \quad \text{is defined,}$$

then almost always

$$\lim_{x \rightarrow a} F(x) = E(a).$$

For example, for

$$F(x) = \frac{x^4 - a^4}{x - a}, \quad F(a) \quad \text{is meaningless.}$$

But,

$$\begin{aligned} \text{for } x \neq a, \quad F(x) &= \frac{(x-a)(x^3 + ax^2 + a^2x + a^3)}{x-a} \\ &= x^3 + x^2a + xa^2 + a^3 \\ &= E(x). \end{aligned}$$

$$\text{and } E(a) = 4a^3, \quad \text{and } \lim_{x \rightarrow a} F(x) = 4a^3.$$

The simple procedure just discussed fails when considering more complex limits such as

$$\lim_{x \rightarrow 0} \frac{\sin x}{x}, \quad \lim_{x \rightarrow 1} \frac{\log x}{x-1}, \quad \text{and} \quad \lim_{x \rightarrow 1} \frac{2^x - 2}{x-1}.$$

Limit of the composition of two functions. A formula for the limit of the composition of two functions has very broad application.

Suppose u is a function, L is a number, a is in the domain of u , and there is an open interval (p, q) in the domain of u that contains a and if x is in (p, q) and is not a then $u(x) \neq L$. Suppose further that

$$\lim_{x \rightarrow a} u(x) = L$$

Suppose F is a function and for x in (p, q) , $u(x)$ is in the domain of F , and

$$\lim_{s \rightarrow L} F(s) = \lambda.$$

Then

$$\lim_{x \rightarrow a} F(u(x)) = \lambda \tag{3.17}$$

Intuitively, if x is close to but distinct from a , then $u(x)$ is close to but distinct from L and $F(u(x))$ is close to λ . The formal argument is perhaps easier than the statement of the property, but is omitted.

Some formulas that follow from Equation 3.17 and previous formulas include

$$\text{If } \lim_{x \rightarrow a} F(x) = L > 0, \quad \text{then} \quad \lim_{x \rightarrow a} \sqrt{F(x)} = \sqrt{L}.$$

$$\text{If } \lim_{x \rightarrow a} F(x) = L \neq 0, \quad \text{then} \quad \lim_{x \rightarrow a} \frac{1}{F(x)} = \frac{1}{L}.$$

$$\text{If } \lim_{x \rightarrow a} F_2(x) \neq 0, \quad \text{then} \quad \lim_{x \rightarrow a} \frac{F_1(x)}{F_2(x)} = \frac{\lim_{x \rightarrow a} F_1(x)}{\lim_{x \rightarrow a} F_2(x)}. \tag{3.18}$$

Exercises for Section 3.2, Limit and rate of change as a limit.

Exercise 3.2.1

- Find a number, $\delta > 0$, so that if x is a number and $0 < |x - 2| < \delta$ then $|2x - 4| < 0.01$.
- Find a number, δ , so that if x is a number and $0 < |x - 2| < \delta$ then $|x^2 - 4| < 0.01$.
- Find a number, δ , so that if x is a number and $0 < |x - 2| < \delta$ then $\left|\frac{1}{x} - \frac{1}{2}\right| < 0.01$.
- Find a number, δ , so that if x is a number and $0 < |x - 2| < \delta$ then $|x^3 - 8| < 0.01$.
- Find a number, δ , so that if x is a number and $0 < |x - 2| < \delta$ then $\left|\frac{x}{x+1} - \frac{2}{3}\right| < 0.01$.
- Find a number, $\delta > 0$, so that if x is a number and $0 < |x - 9| < \delta$ then $|\sqrt{x} - 3| < 0.01$.
- Find a number, δ , so that if x is a number and $0 < |x - 8| < \delta$ then $|\sqrt[3]{x} - 2| < 0.01$.
- Find a number, $\delta > 0$, so that if x is a number and $0 < |x - 2| < \delta$ then $|x^4 - 3x - 13| < 0.01$.

Exercise 3.2.2 a. Find a number, $\delta > 0$, so that

$$\text{if } x \text{ is a number and } |x - 3| < \delta \quad \text{then} \quad \left| \frac{x^2 - 9}{x - 3} - 6 \right| < 0.01.$$

- b. Find a number,
- $\delta > 0$
- , so that

$$\text{if } x \text{ is a number and } |x - 4| < \delta \quad \text{then} \quad \left| \frac{\sqrt{x} - 2}{x - 4} - \frac{1}{4} \right| < 0.01.$$

- c. Find a number,
- $\delta > 0$
- , so that

$$\text{if } x \text{ is a number and } |x - 2| < \delta \quad \text{then} \quad \left| \frac{\frac{1}{x} - \frac{1}{2}}{x - 2} + \frac{1}{4} \right| < 0.01.$$

- d. Find a number,
- $\delta > 0$
- , so that

$$\text{if } x \text{ is a number and } |x - 1| < \delta \quad \text{then} \quad \left| \frac{x^2 + x - 2}{x - 1} - 3 \right| < 0.01.$$

Exercise 3.2.3 a. Use Equations 3.11 and 3.15,

$$\lim_{x \rightarrow a} x = a \quad \text{and} \quad \lim_{x \rightarrow a} F_1(x) \times F_2(x) = \left(\lim_{x \rightarrow a} F_1(x) \right) \times \left(\lim_{x \rightarrow a} F_2(x) \right),$$

to show that

$$\lim_{x \rightarrow a} x^2 = a^2.$$

- b. Show that

$$\lim_{x \rightarrow a} x^3 = a^3.$$

- c. Show by induction that if
- n
- is a positive integer,

$$\lim_{x \rightarrow a} x^n = a^n. \tag{3.19}$$

Exercise 3.2.4 Prove the following theorem.

Theorem 3.2.1 : Limit is Unique Theorem. Suppose G is a function and

$$\lim_{x \rightarrow a} G(x) = L_1 \quad \text{and} \quad \lim_{x \rightarrow a} G(x) = L_2.$$

Then $L_1 = L_2$.

Begin your proof with,

1. Suppose that $L_1 < L_2$.
2. Let $\epsilon = (L_2 - L_1)/2$.

Exercise 3.2.5 Evaluate the limits.

a. $\lim_{x \rightarrow 5} 3x^2 - 15x$	b. $\lim_{x \rightarrow 0} 3x$	c. $\lim_{x \rightarrow 50} \pi$
d. $\lim_{x \rightarrow -2} 3x^2 - 15x$	e. $\lim_{x \rightarrow -\pi} x$	f. $\lim_{x \rightarrow \pi} 50$
g. $\lim_{x \rightarrow 5} \frac{x-1}{x-1}$	h. $\lim_{x \rightarrow 1} \frac{x^2 - 2x + 1}{x-1}$	i. $\lim_{x \rightarrow 1} \frac{x^4 - 1}{x-1}$
j. $\lim_{x \rightarrow 4} \frac{x}{\sqrt{x+2x^2}}$	k. $\lim_{x \rightarrow 1} \sqrt{\frac{x-2}{x^3+1}}$	l. $\lim_{x \rightarrow 1} \sqrt{\frac{x-3}{x^3-27}}$

Exercise 3.2.6 Sketch the graph of $y = \sqrt[3]{x}$ for $-1 \leq x \leq 1$. Does the graph have a tangent at $(0,0)$? Remember, **Your vote counts**.

Exercise 3.2.7 Suppose $P(x) = a_n x^n + a_{n-1} x^{n-1} + \cdots + a_1 x + a_0$ is a polynomial and a is a number. For each step (i) through (vii), identify the equation of Equations 3.10 - 3.14 and 3.19 that justify the step.

$$\begin{aligned} \lim_{x \rightarrow a} P(x) &= \lim_{x \rightarrow a} (a_n x^n + a_{n-1} x^{n-1} + \cdots + a_1 x + a_0) \\ &= \lim_{x \rightarrow a} (a_n x^n) + \lim_{x \rightarrow a} (a_{n-1} x^{n-1} + \cdots + a_1 x + a_0) && (i) \\ &= \lim_{x \rightarrow a} (a_n x^n) + \lim_{x \rightarrow a} (a_{n-1} x^{n-1}) + \lim_{x \rightarrow a} (a_{n-2} x^{n-2} \cdots + a_1 x + a_0) && (ii) \\ &\vdots \\ &= \lim_{x \rightarrow a} (a_n x^n) + \cdots + \lim_{x \rightarrow a} (a_2 x^2) + \lim_{x \rightarrow a} (a_1 x + a_0) \\ &= \lim_{x \rightarrow a} (a_n x^n) + \cdots + \lim_{x \rightarrow a} (a_2 x^2) + \lim_{x \rightarrow a} (a_1 x) + \lim_{x \rightarrow a} (a_0) && (iii) \\ &= a_n \lim_{x \rightarrow a} (x^n) + \cdots + a_2 \lim_{x \rightarrow a} (x^2) + a_1 \lim_{x \rightarrow a} (x) + \lim_{x \rightarrow a} (a_0) && (iv) \\ &= a_n a^n + \cdots + a_2 a^2 + a_1 \lim_{x \rightarrow a} (x) + \lim_{x \rightarrow a} (a_0) && (v) \\ &= a_n a^n + a_{n-1} a^{n-1} + \cdots + a_2 a^2 + a_1 a + \lim_{x \rightarrow a} (a_0) && (vi) \\ &= a_n a^n + a_{n-1} a^{n-1} + \cdots + a_2 a^2 + a_1 a + a_0 && (vii) \\ &= P(a) && \text{Whew!} \end{aligned}$$

Exercise 3.2.8 . Show that Equation 3.13,

$$\lim_{x \rightarrow a} C F_1(x) = C \left(\lim_{x \rightarrow a} F_1(x) \right)$$

follows from Equations 3.10 and 3.15,

$$\lim_{x \rightarrow a} C = C \quad \text{and} \quad \lim_{x \rightarrow a} (F_1(x) F_2(x)) = \left(\lim_{x \rightarrow a} F_1(x) \right) \left(\lim_{x \rightarrow a} F_2(x) \right)$$

Exercise 3.2.9 Some of the following statements are true and some are false. For those that are true, provide proofs using Equations 3.10 - 3.15. For those that are false, provide functions F_1 and F_2 to show that they are false. Assume the limits shown do exist.

Suppose F_1 and F_2 are functions defined for all numbers, x .

- a. If $\lim_{x \rightarrow a} (F_1(x) - F_2(x)) = 0$, then $\lim_{x \rightarrow a} F_1(x) = \lim_{x \rightarrow a} F_2(x)$.
- b. If $\lim_{x \rightarrow a} (F_1(x) F_2(x)) = 0$, then $\lim_{x \rightarrow a} F_1(x) = \lim_{x \rightarrow a} F_2(x) = 0$.
- c. If $\lim_{x \rightarrow a} \frac{F_1(x)}{F_2(x)} = 0$, then $\lim_{x \rightarrow a} F_1(x) = 0$.
- d. If $\lim_{x \rightarrow a} F_1(x) = 0$, then $\lim_{x \rightarrow a} \frac{F_1(x)}{F_2(x)} = 0$.
- e. If $\lim_{x \rightarrow a} (F_1(x) F_2(x)) = 0$, then $\lim_{x \rightarrow a} F_1(x) = 0$ or $\lim_{x \rightarrow a} F_2(x) = 0$.

Exercise 3.2.10

Evaluate $\lim_{x \rightarrow a} \frac{F(x) - F(a)}{x - a}$ for

- a. $F(x) = x^2$ $a = -2$ b. $F(x) = 17$ $a = 0$
- c. $F(x) = 2x^3$ $a = 2$ d. $F(x) = x^2 + 2x$ $a = 1$
- e. $F(x) = \frac{1}{x}$ $a = \frac{1}{2}$ f. $F(x) = 3x^2 - 5x$ $a = 7$
- g. $F(x) = 3\sqrt{x}$ $a = 4$ h. $F(x) = x^2 + 2x + 1$ $a = -1$
- i. $F(x) = \frac{4}{x} + 5$ $a = 2$ j. $F(x) = x^6$ $a = 2$
- k. $F(x) = \frac{1}{x^3}$ $a = 2$ l. $F(x) = x^{10}$ $a = 2$
- m. $F(x) = \frac{4}{x^5}$ $a = 2$ n. $F(x) = x^{67}$ $a = 1$

Exercise 3.2.11 Suppose $F(x)$ is a function and

$$\lim_{b \rightarrow 2} \frac{F(b) - F(2)}{b - 2} \quad \text{exists.}$$

What is $\lim_{b \rightarrow 2} F(b)$?

3.3 The derivative function, F'

Definition 3.3.1 The function, F' . Suppose F is a function and for some number, x , in its domain the rate of change of F exists at x . Then the function F' (read 'F prime') is defined by

$$F'(x) = \text{the rate of change of } F \text{ at } x \quad (3.20)$$

for all numbers x in the domain of F for which the rate of change of F at x exists.

Equivalently,

$$F'(x) = \text{the slope of the graph of } F \text{ at } (x, F(x)) \quad (3.21)$$

for points $(x, F(x))$ of the graph of F for which the tangent exists.

Symbolically, we may write

$$F'(x) = \lim_{b \rightarrow x} \frac{F(b) - F(x)}{b - x}. \quad (3.22)$$

The function F' is called the *derivative*⁴ of F (the function *derived* from F). When the independent variable of F is expressed as in $F(x)$, $F'(x)$ is the derivative of $F(x)$ with respect to x .

The derivative is one-half of calculus, perhaps 4 percent of your university education, and requires your attention. The next 200? pages of this text present biological and physical interpretations of the derivative, formulas for computing the derivatives of commonly encountered functions, and uses of derivatives in writing equations for mathematical models of biological and physical systems.

Example 3.3.1 You found in Chapter 1, Problem 1.9.1 on page 45 that light intensity, L , at a distance, d , from a linear slit of light was

$$L(d) = \frac{1.45}{d} \quad 3 \leq d \leq 16$$

where L was measured in mW/cm^2 and d was measured in cm.

⁴Joseph-Louis Lagrange (a French mathematician of Italian descent, 1736-1813) used the word 'derivative', and may have been the first to do so (H. L. Vacher, Computational geology 5 – If geology, then calculus, *J. Geosci. Educ.*, 1999, **47** 186-195).

At what rate is the light decreasing when $d = 5$ cm? We find the derivative of L . For any value of d between 3 and 16 cm,

$$\begin{aligned} L'(d) &= \lim_{b \rightarrow d} \frac{L(b) - L(d)}{b - d} \frac{\text{mW/cm}^2}{\text{cm}} \\ &= \lim_{b \rightarrow d} \frac{\frac{1.45}{b} - \frac{1.45}{d}}{b - d} \frac{\text{mW/cm}^2}{\text{cm}} \\ &= \lim_{d \rightarrow 5} \left(-1.45 \frac{1}{d \times b} \right) \frac{\text{mW/cm}^2}{\text{cm}} \\ &= \frac{-1.45}{d^2} \frac{\text{mW/cm}^2}{\text{cm}} \end{aligned}$$

$$\text{For } d = 5, \quad L'(5) = \frac{-1.45}{d^2} \Big|_{d=5} = \frac{-1.45}{5^2} = -0.058 \frac{\text{mW/cm}^2}{\text{cm}}.$$

We have just used a helpful notation: $|_{x=a}$

For any function, G , $G(x)|_{x=a} = G(a)$.

It is useful to compare the algebraic forms of L and L' ,

$$L(d) = \frac{k}{d} \quad \text{and} \quad L'(d) = -k \frac{1}{d^2}, \quad \text{and note that} \quad L'(d) = -\frac{1}{k} L^2(d).$$

Explore 3.3.1 For one mole of oxygen at 300° Kelvin the pressure, P in atmospheres, and volume, V in liters, are related by

$$P = \frac{1 \times 0.0820 \times 300}{V}$$

- a. Find the derivative of P with respect to V .
- b. What is $P'(1)$?

■

The question of units on the rate of change is important. We have used the following.

Units on F'

If $\lim_{x \rightarrow a} G(x) = L$, then the units on L are the units on G .

It follows that the units on

$$F'(x) = \lim_{b \rightarrow x} \frac{F(b) - F(x)}{b - x}$$

are the units on F divided by the the units on the domain of F (the units on x).

- If $F(t)$ is distance in meters and t is time in seconds, then $F'(t)$ is meters per second, or velocity.
- If $F(x)$ is pressure in atmospheres and x is altitude in km, then $F'(x)$ is commonly called the pressure *gradient* and is measured in atm/km.
- If $F(t)$ is population size in individuals and t is time in years, then $F'(t)$ is population growth rate (which might be negative) in individuals per year.

It is useful to see the rate of change of F over the whole domain of F . In Figure 3.15A is the graph of a function, called a logistic function, that is typical of the size of population that starts at low density and grows in a limited environment. At time $t = 0$ the population size is $P(0) = 1$ and the maximum supportable population is $M = 10$. Its derivative is shown in 3.15B and illustrates population growth rate. The maximum of the derivative occurs at $t \doteq 3.17$ and this marks the steepest part of the population graph. The growth rate initially is low, rises to a maximum at $t \doteq 3.17$, and decreases again as population density nears its maximum.

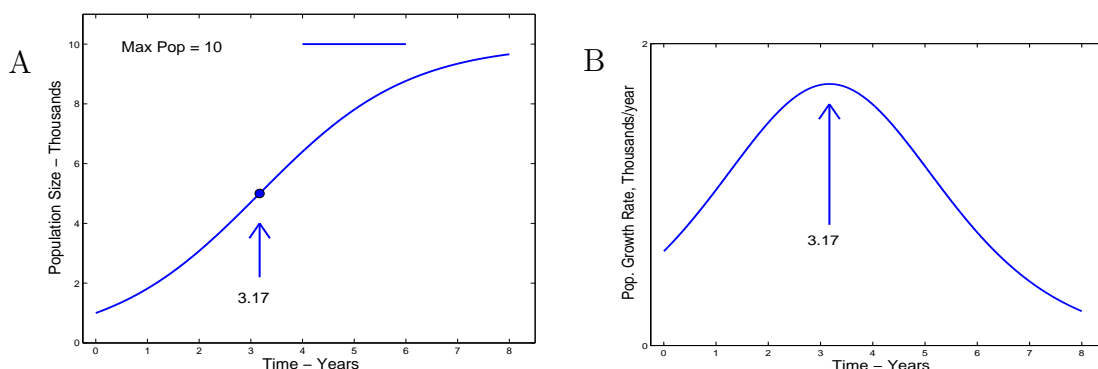

Figure 3.15: A. Graph of a classical logistic curve, L , describing population size as a function of time. B. A graph of L' , the population growth rate.

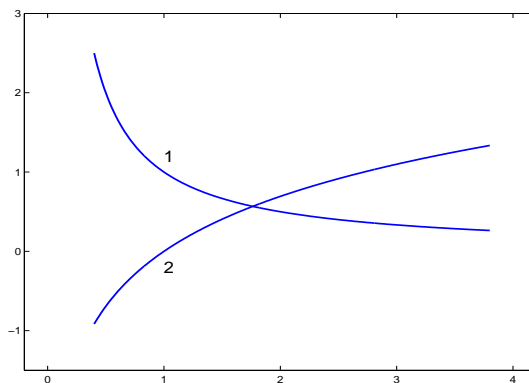

Figure 3.16: The graph of a function P and its derivative P' .

Example 3.3.2 Problem. The graphs of a function P and its derivative P' are shown in Figure 3.16. Which graph is the graph of P ?

Solution. We claim that graph 1 is not P , because every tangent to graph 1 has negative slope and some y -coordinates of graph 2 are positive. Therefore graph 2 must be the graph of P .

Alternate notation. Calculus originated in England with Sir Isaac Newton (1642-1727) and in Germany with Gottfried Wilhelm Leibniz (1646-1716), and indeed some elements of it were anticipated by the Greek mathematicians. Given the multiple origins and a 300 year history, it is not surprising that there are several notations for derivative. Newton used y' for the ‘fluxion’ of y (rate of change of y). But when the independent variable was time, Newton used the symbol \dot{y} for the rate of change of y and \ddot{y} for the second derivative of y (the derivative of the derivative of y). Therefore if y denotes distance, \dot{y} denotes velocity and \ddot{y} denotes acceleration. The most common notation, $\frac{dF}{dt}$, for the derivative was introduced and used by Leibnitz. When discussing the rate of change of F at a number a one may see

$$F'(a) \quad \text{or} \quad \left. \frac{dF}{dx} \right|_{x=a} \quad \text{or} \quad \frac{dF}{dx} \quad \text{or} \quad \dot{F} \quad \text{or} \quad \dot{F}(a)$$

A function that has a derivative is called a *differentiable* function. To *differentiate* F means to compute the derivative, F' . “Differentiable” comes from the concept of a ‘differential’ which is a cousin of an elusive concept called ‘infinitesimal’. An infinitesimal is a positive number that is less than all other positive numbers, which is possible only in an extension of our familiar number system. An infinitesimal change, dx , in x causes an infinitesimal change, dF , in $F(x)$ and the derivative is the ratio $\frac{dF}{dx}$. The concept of a limit is considered to be less mysterious than is infinitesimal, and can easily be put on a quite sound footing, whereas it is difficult to define ‘infinitesimal’ clearly⁵.

It is sometimes preferable to substitute h for $b - x$ so that $b = x + h$, and write

$$F'(x) = \lim_{b \rightarrow x} \frac{F(b) - F(x)}{b - x} \quad \text{as} \quad F'(x) = \lim_{h \rightarrow 0} \frac{F(x + h) - F(x)}{h}. \quad (3.23)$$

⁵Abraham Robinson, *Nonstandard Analysis*, Princeton University Press, 1996 is a recent book defining calculus based on infinitesimals.

Exercises for Section 3.3, The derivative function, F' .

Exercise 3.3.1 Use Equation 3.22,

$$F'(x) = \lim_{b \rightarrow x} \frac{F(b) - F(x)}{b - x},$$

to compute $F'(x)$ for

- | | | |
|---------------------------|---------------------------|-------------------------------|
| a. $F(x) = x^2$ | b. $F(x) = 2x^2$ | c. $F(x) = x^2 + 1$ |
| d. $F(x) = x^3$ | e. $F(x) = 4x^3$ | f. $F(x) = x^3 - 1$ |
| g. $F(x) = x^2 + x$ | h. $F(x) = x^2 + x^3$ | i. $F(x) = 3x + 1$ |
| j. $F(x) = \sqrt{x}$ | k. $F(x) = 4\sqrt{x}$ | l. $F(x) = 4 + \sqrt{x}$ |
| m. $F(x) = 5$ | n. $F(x) = \frac{1}{x}$ | o. $F(x) = 5 + \frac{1}{x}$ |
| p. $F(x) = \frac{1}{x^2}$ | q. $F(x) = \frac{5}{x^2}$ | r. $F(x) = 5 + \frac{1}{x^2}$ |

Exercise 3.3.2 Use the equation,

$$F'(x) = \lim_{h \rightarrow 0} \frac{F(x+h) - F(x)}{h},$$

to compute $F'(x)$ for:

- | | | |
|--------------------|---------------------|------------------------|
| a. $F(x) = x^2$ | b. $F(x) = 3x^2$ | c. $F(x) = x^2 + 5$ |
| d. $F(x) = x^{-1}$ | e. $F(x) = 2x^{-1}$ | f. $F(x) = x^{-1} - 7$ |

Exercise 3.3.3 In Figure Ex. 3.3.3A and Figure Ex. 3.3.3B are four pairs of graphs of a function P and its derivative, P' . For each pair, which is the graph of P ? Explain your choice.

Figure for Exercise 3.3.3 A. Graphs of a function and its derivative for Exercise 3.3.3.

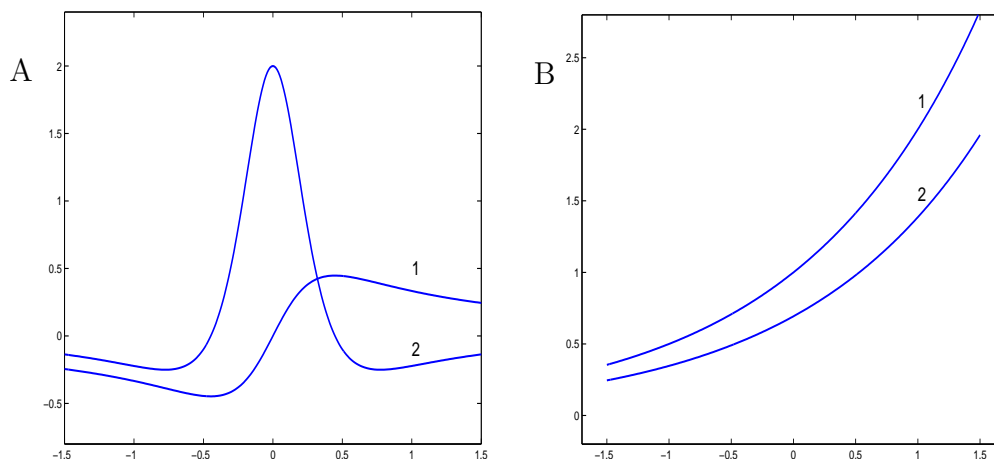
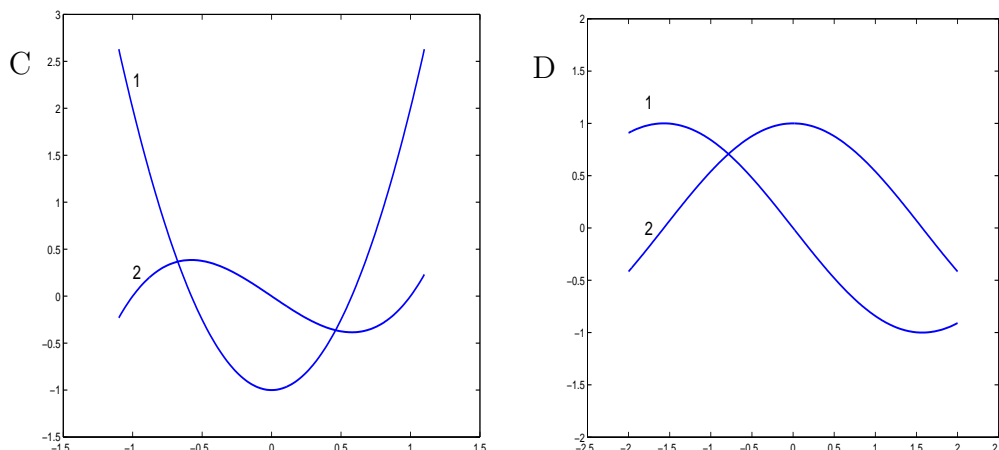
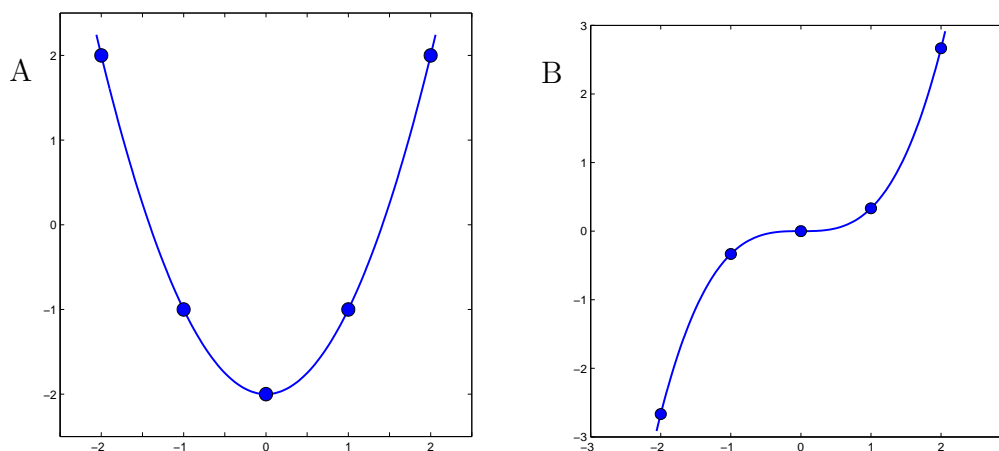

Figure for Exercise 3.3.3 B. Graphs of a function and its derivative for Exercise 3.3.3.



Exercise 3.3.4 a. In Exercise Figure 3.3.4A is the graph of a function, F . Estimate the slopes of the tangents to that graph at the points marked on the graph. Plot a new graph of slopes vs the dependent variable for F . Sketch a graph of F' .
 b. Repeat the steps of the part a. for the graph of a function, G , in Exercise Figure 3.3.4B.

Figure for Exercise 3.3.4 A. Graph of a function F for Exercise 3.3.4a. B. Graph of a function G for Exercise 3.3.4b.



Exercise 3.3.5 Danger: Obnubilation Zone.

a. Shown in Exercise Figure 3.3.5A is a graph of the derivative, F' , of a function, F . One point of the graph of F is $(0,2)$ (that is, $F(0) = 2$). Your job, should you accept it, is to sketch a reasonable graph of F .
 b. Repeat the steps of a. to sketch a graph of a function G knowing that $G(1) = 0$ and the graph of $G'(x)$ is shown in Exercise Figure 3.3.5B. (Consider: What is the slope of G at $x = 1$? What is the slope of G at $x = 2$? What is the slope of G at $x = 3$?)

Figure for Exercise 3.3.5 A. Graph of F' for a function F for Exercise 3.3.5a. B. Graph of G' for a function G for Exercise 3.3.5b.

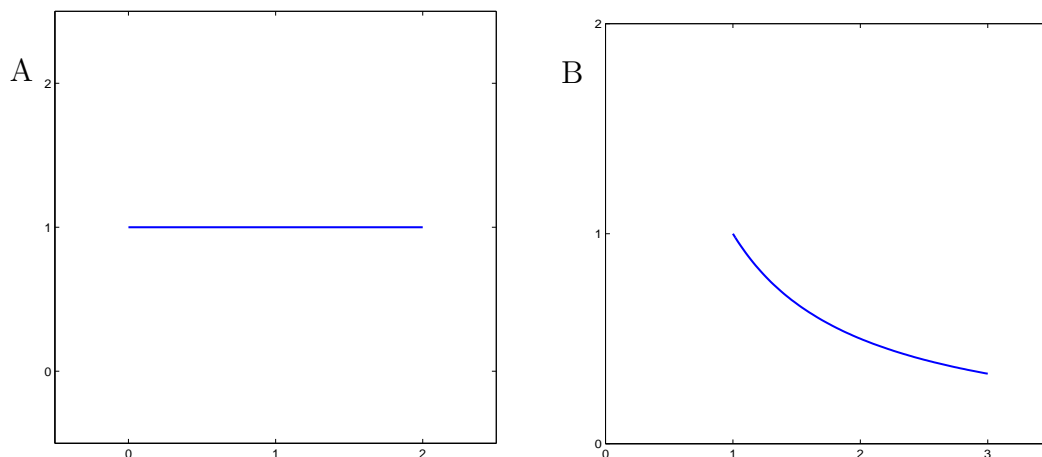

Exercise 3.3.6 In Figure 3.15A it appears that at $t = 6$ years the population was about 8.75 thousand, or 8,750 individuals and that the growth rate was about 0.75 thousand per year, or 750 individuals per year. Suppose this is a deer population and you wished to allow hunters to harvest some deer each year. How many deer could be harvested each year and the population size remain at 8,750 individuals?

Exercise 3.3.7 Technology. The function

$$P(t) = \frac{10 \cdot 2^t}{9 + 2^t} = \frac{10}{9 \cdot 2^{-t} + 1}$$

is an example of a logistic function, a type of function that often is used to describe the growth of populations. Plot the graph of this function for $0 \leq t \leq 10$, $0 \leq y \leq 20$. Find how to plot $P'(t)$ and locate the highest point of $P'(t)$ on your technology. MATLAB code is

```
close all;clc;clear; h=0.001; x=[0:h:5]; y=10./(9*2.^(-x)+1);
z=diff(y)/h; [m,i]=max(z); [x(i) y(i) z(i)]
plot(x,y,'linewidth',2); hold('on')
plot(x(i),y(i),'x','linewidth',3)
plot(x(1:length(x)-1),z,'r','linewidth',2)
plot(x(i),z(i),'xr','linewidth',3)
```

At what time and population size is the population growing the fastest?

Exercise 3.3.8 The square function, $S(t) = t^2$, $t \geq 0$, and the square root function, $R(t) = \sqrt{t}$, $t \geq 0$, are each inverses of the other. See Figure Ex. 3.3.8. Compare the slopes of the tangents to S at the points (2,4), (3,9), and (4,16) with the slopes of R at the respectively corresponding points, (4,2), (9,3), and (16,4) of R . Compare the slope of the graph of S at the point (a, a^2) , $a > 0$ with the slope of the graph of R at the corresponding point (a^2, a) .

Figure for Exercise 3.3.8 Graphs of $S(t) = t^2$ and $R(t) = \sqrt{t}$. See Exercise 3.3.8.

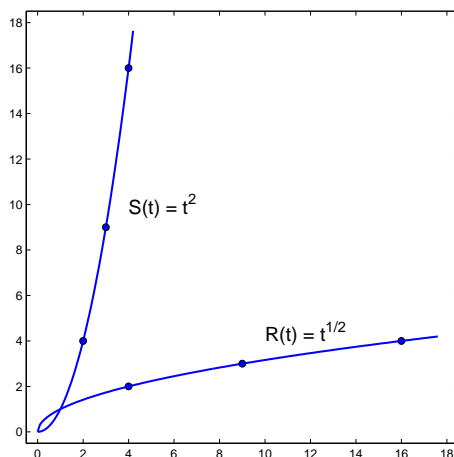

The next two exercises explore the reflective property of a parabola which asserts that light rays originating from the focal point of a parabola will strike the parabola and be reflected in a direction parallel to the axis of the parabola. We choose the parabola that is the graph of $y = 2\sqrt{t}$ which has $(1,0)$ as its focal point and $x = -1$ as its directrix.

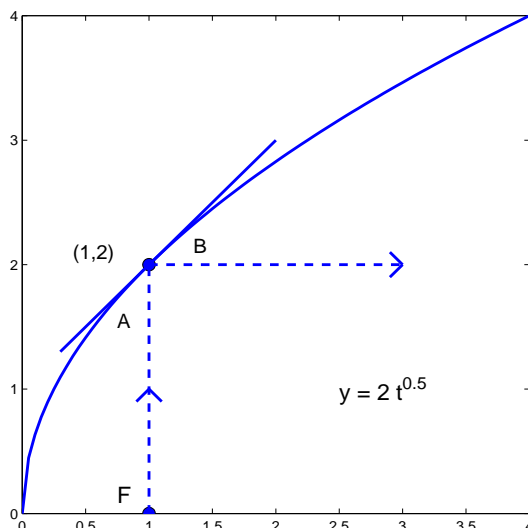

Figure 3.17: A parabolic reflector used to boil water in the kettle that is at the focal point of the dish, in Lhasa, Tibet.

Exercise 3.3.9 Shown in Figure Ex. 3.3.9 is the graph of $y = 2\sqrt{t}$ and a ray emanating vertically from the focal point at $(1,0)$ and reflected (apparently horizontally) by the tangent to the parabola at $(1,2)$. The angles A (of incidence) and B (of reflection) are equal.

- Compute the slope of the tangent to $y = 2\sqrt{t}$ at the point $(1,2)$.
- Argue that the angle A in Figure Ex. 3.3.9 is 45° .
- Argue that the angle B in Figure Ex. 3.3.9 is 45° .
- Argue that the reflected ray from $(1,2)$ is horizontal.

Figure for Exercise 3.3.9 Graph of the parabola $y = 2\sqrt{t}$ and a ray (dashed line) emanating vertically from the focal point $(1,0)$ and reflected at $(1,2)$. See Exercise 3.3.9.



Exercise 3.3.10 Shown in Figure Ex. 3.3.10 is the graph of $y = 2\sqrt{t}$, and a ray (dashed line) from the focal point, $(1,0)$, to the point $(a, 2\sqrt{a})$, and a tangent, T , to the parabola at $(a, 2\sqrt{a})$. Our goal is to show that the reflected ray (dashed line with arrow head) is horizontal (but it has not been drawn that way). The two angles marked β are equal because they are vertical angles of intersecting lines.

It will be sufficient to show that the angle of reflection, B , is also β , the angle of inclination of the tangent T . Because B and β are acute, it will be sufficient to show that $\tan B = \tan \beta$.

- Argue that $C = A + \beta$, so that $A = C - \beta$.
- Argue that $B = A$, so that $B = C - \beta$.
- Compute the slope of the tangent T to the graph of $y = 2\sqrt{t}$ at $(a, 2\sqrt{a})$. By definition, this number is also $\tan \beta$.
- Compute $\tan C$.
- Use the trigonometric identity

$$\tan(C - \beta) = \frac{\tan C - \tan \beta}{1 + \tan C \tan \beta}$$

to show that $\tan B = \tan(C - \beta) = \frac{1}{\sqrt{a}}$.

Because $\tan B = \tan \beta$, $B = \beta$ and the reflected ray is horizontal.

Figure for Exercise 3.3.10 Graph of the parabola $y = 2\sqrt{t}$ and a ray (dashed line) emanating vertically from the focal point $(1,0)$ and reflected at a point $(a, 2\sqrt{a})$. See Exercise 3.3.10.

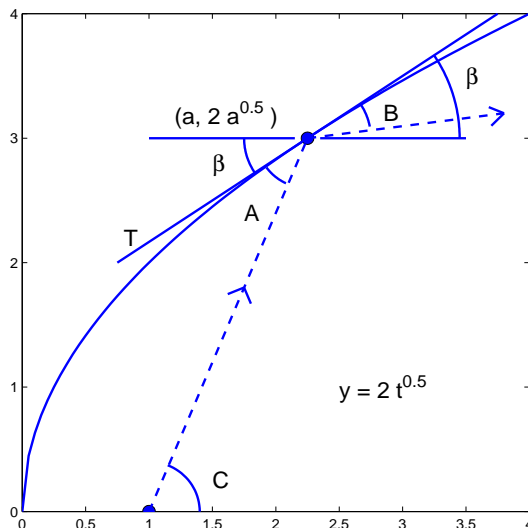

3.4 Mathematical models using the derivative.

The rate of change of a function provides a powerful new way of thinking about models of biological processes.

The changes in biological and physical properties that were measured in discrete packages ($P_{t+1} - P_t$, $A_{t+1} - A_t$, $I_{t+1} - I_t$) in Chapter 1 can be more accurately represented as instantaneous rates of change ($P'(t)$, $A'(t)$, $I'(t)$) using the derivative. In Section 1.1, Table 1.1, the *V. natriegens* population was measured at 16 minute intervals but was growing continuously. The kidneys filter continuously, not in 5-minute spurts. Here we begin a process of using the derivative to interpret mathematical models that continues through out the book.

3.4.1 Mold growth.

We wrote in Section 1.5 that the *daily* increase in the area of a mold colony is proportional to the circumference of the colony at the beginning of the day. Alternatively, we might say:

Mathematical Model 3.4.1 Mold growth. The rate of increase in the area of the mold colony at time t is proportional to the circumference of the colony at time t .

Letting $A(t)$ be area and $C(t)$ be circumference of the mold colony at time t , we would write

$$A'(t) = k C(t)$$

Because $C(t) = 2\sqrt{\pi}\sqrt{A(t)}$ (assuming the colony is circular)

$$A'(t) = k 2\sqrt{\pi}\sqrt{A(t)} = K\sqrt{A(t)} \tag{3.24}$$

where $K = k 2\sqrt{\pi}$.

Equation 3.24, $A'(t) = K\sqrt{A(t)}$, is a statement about the function A . We recall also that the area of the colony on day 0 was 4 mm^2 . Now we search for a function A such that

$$A(0) = 4 \quad A'(t) = K\sqrt{A(t)} \quad t \geq 0 \quad (3.25)$$

Warning: Incoming Lightning Bolt. Methodical ways to search for functions satisfying conditions such as Equations 3.25 are described in Chapter 17. At this stage we only write that the function

$$A(t) = \left(\frac{K}{2}t + 2\right)^2 \quad t \geq 0 \quad \text{Bolt Out of Chapter 17.} \quad (3.26)$$

satisfies Equations 3.25 and is the only such function. In Exercise 3.6.7 you are asked to confirm that $A(t)$ of Equation 3.26 is a solution to Equation 3.25.

Finally, we use an additional data point, $A(8) = 266$ to find an estimate of K in $A(t) = \left(\frac{K}{2}t + 2\right)^2$.

$$A(8) = \left(\frac{K}{2}8 + 2\right)^2$$

$$266 = (4K + 2)^2$$

$$K \doteq 3.58$$

Therefore, $A(t) = (1.79t + 2)^2$ describes the area of the mold colony for times $0 \leq t \leq 9$.

Furthermore, A has a quadratic expression as suggested in Section 1.5 based on a discrete model. A graph of the original data and A appears in Figure 3.18.

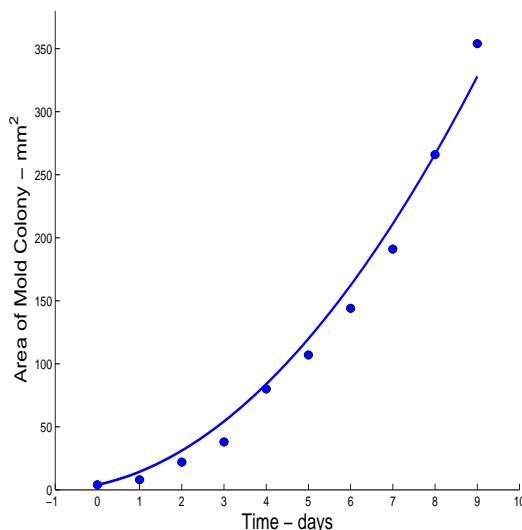

Figure 3.18: Graph of $A(t) = (1.79t + 2)^2$ and the area of a mold colony from Table 1.5

3.4.2 Difference Equations and Differential Equations.

We have just seen our first example of a **differential equation**, Equation 3.24. It writes the derivative, $A'(t)$, of a function in terms of the function, $= K\sqrt{A(t)}$. We prefer the term **derivative**

equation but defer to the almost universal use of *differential equation*. The comparison is

$$A_{t+1} - A_t = K\sqrt{A_t} \quad A_0 = 4$$

Difference Equation

$$A'(t) = K A(t) \quad A(0) = 4$$

vs

Differential Equation

Differential equations often more accurately represent the biological, physical chemical, economic, or social system under study because the equation and solution are defined throughout a time interval or space interval, whereas difference equations and solutions are defined only for discrete sequences of numbers, and maybe a finite sequence. Deer populations that breed only annually, however, may be better represented by a difference equation

Difference equations are inherently simpler than differential equations. Solutions to difference equations require only arithmetic, whereas solutions to differential equations involve calculus. The solution to the difference equation above seems to only have an arithmetically derived solution. The corresponding differential equation has a simple algebraic solution, $\left(\frac{K}{2}t + 2\right)^2$. You have to wait 14 chapters before we describe its derivation, but we will write and solve differential equations in Chapters 5, 7 and 13.

Some computers will return solutions to differential equations, much as looking up addresses in a telephone book. Give 'White Pages' on the internet a name and area code, and it will return the address, telephone number, age and close associates of a person, and perhaps another one or two people, with that name and area code. Computers are very adept, however, at computing approximate solutions to some very complex differential equations, such as those that describe the path of a manned space craft traveling to the moon. Ironically, what they actually do is compute solutions to difference equations closely associated with the a differential equation; computers are arithmetic whizzes.

3.4.3 Chemical kintetics.

Chemists use the *rate of change in the amount of product* from a chemical reaction as a measure of the *reaction rate*. You will compute some rates of chemical reactions from discrete data of chemical concentration *vs* time.

Chemical reactions in which one combination of chemicals changes to another are fundamental to the study of chemistry. It is important to know how rapidly the reactions occur, and to know what factors affect the rate of reaction. A reaction may occur rapidly as in an explosive mixture of chemicals or slowly, as when iron oxidizes on cars in a junk yard. Temperature and concentration of reactants often affect the reaction rate; other chemicals called catalysts may increase reaction rates; in many biological processes, there are enzymes that regulate the rate of a reaction. Consider



to represent (part of) a reaction in which a reactant, A, changes to a product, B. The rate of the reaction may be measured as the rate of disappearance of A or the rate of appearance of B.

Time sec	Cl ⁻ mmol	Time sec	Cl ⁻ mmol
0	0.014	80	2.267
10	0.188	90	2.486
20	0.456	100	2.683
30	0.762	110	2.861
40	1.089	120	3.010
50	1.413	130	3.144
60	1.728	140	3.255
70	2.015	150	3.355

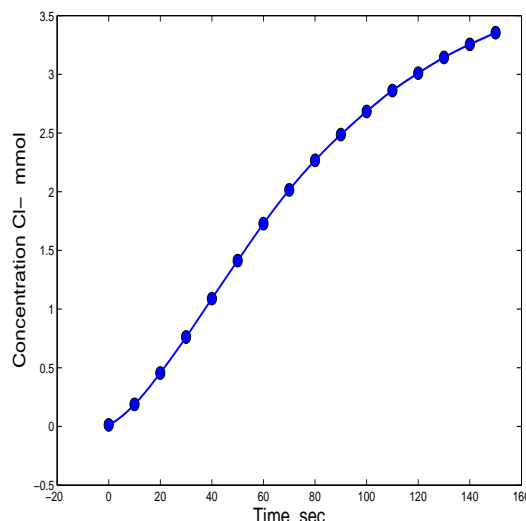
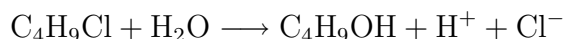

Figure 3.19: Conductivity of a water and butyl chloride solution at times after butyl chloride was added to water.

Butyl chloride.

When butyl chloride, C_4H_9Cl , is placed in water, the products are butyl alcohol and hydrochloric acid. The reaction is



As it takes one molecule of C_4H_9Cl to produce one atom of Cl^- , the rate at which butyl chloride disappears is the same as the rate at which hydrochloric acids appears. The presence of Cl^- may be measured by the conductivity of the solution. Two students measured the conductivity of a solution after butyl chloride was added to water, and obtained the results shown in Figure 3.19. The conductivity probe was calibrated with 8.56 mmol NaCl, and conductivity in the butyl chloride experiment was converted to mmol Cl^- . The experiment began with butyl chloride being added to water to yield 9.6 mmol butyl chloride.

The average rate of change over the time interval $[30,40]$

$$m_{30,40} = \frac{1.089 - 0.762}{40 - 30} = 0.0327,$$

and the average rate of change over the time interval $[40,50]$

$$m_{40,50} = \frac{1.413 - 1.089}{50 - 40} = 0.0324.$$

both approximate the reaction rate. A better estimate is the average of these two numbers, $\frac{0.0327+0.0324}{2} = 0.03255$. We only use the average when the backward and forward time increments, -10 seconds and +10 seconds, are of the same magnitude. The average can be computed without computing either of the backward or forward average rates, as

$$m_{30,50} = \frac{1.413 - 0.762}{50 - 30} = 0.03255$$

In the case of $t = 150$, knowledge of the forward time increment is not available, and we use the backward time increment only.

$$m_{140,150} = \frac{3.355 - 3.255}{150 - 140} = 0.01$$

Explore 3.4.1 Estimate the reaction rate at time $t = 80$ seconds. ■

Example 3.4.1 It is useful to plot the reaction rate *vs* the concentration of Cl^- as shown in Figure 3.20. The computed reaction rates for times $t = 0, 10, \dots, 40$ are less than we expected. At these times, the butyl chloride concentrations are highest and we expect the reaction rates to also be highest. Indeed, we expect the rate of the reaction to be proportional to the butyl chloride concentration. If so then the relation between reaction rate and Cl^- concentration should be linear, as in the parts corresponding to times $t = 60, 70, \dots, 160$ s. The line in Figure 3.20 has equation $y = 0.0524 - 0.0127x$. We can not explain the low rate of appearance of Cl^- at this time.

Time sec	Cl^- mmol	Reaction Rate mmol/sec	Time sec	Cl^- mmol	Reaction Rate mmol/sec
0	0.014	0.0175	80	2.267	0.0235
10	0.188	0.0221	90	2.486	0.0208
20	0.456	0.0287	100	2.683	0.0188
30	0.762	0.0317	110	2.861	0.0164
40	1.089	0.0326	120	3.010	0.0141
50	1.413	0.0319	130	3.144	0.0122
60	1.728	0.0301	140	3.255	0.0105
70	2.015	0.0270	150	3.355	0.010

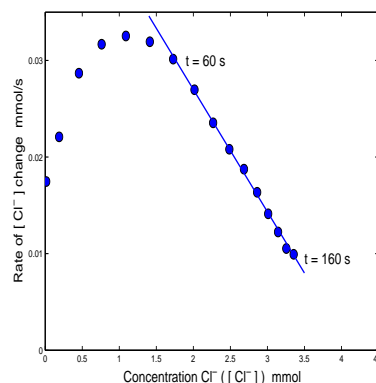
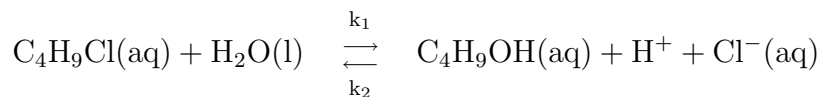

Figure 3.20: Rate at which Cl^- accumulates as a function of Cl^- concentration after butyl chloride is added to water.

The reaction is not quite so simple as represented, for if butyl alcohol is placed in hydrochloric acid, butylchloride and water are produced. You may see from the data that the molarity of Cl^- is tapering off and indeed later measurements showed a maximum Cl^- concentration of 3.9 mmol. If all of the butyl chloride decomposed, the maximum Cl^- concentration would be 9.6, the same as the initial concentration of butyl chloride. There is a reverse reaction and the total reaction may be represented



The numbers, k_1 and k_2 , are called rate constants of the reaction. The number k_1 is the negative of the slope of the line computed in Example 3.4.1 (that is, 0.0127).

Exercises for Section 3.4 Mathematical models using the derivative.

Exercise 3.4.1 Write a derivative equation that describes the following model of mold growth.

Mathematical Model. A mold colony is growing in a circular pattern. The radius of the colony is increasing at a constant rate.

Exercise 3.4.2 Write a derivative equation that describes the following model of light depletion below the surface of a lake.

Mathematical Model. The rate at which light intensity decreases at any depth is proportional to the intensity at that depth.

Exercise 3.4.3 Write a derivative equation that describes the following model of penicillin clearance.

Mathematical Model. The rate at which the kidneys remove penicillin is proportional to the concentration of penicillin.

Exercise 3.4.4 Data from Michael Blaber of Florida State University College of Medicine⁶ for the butyl chloride experiment

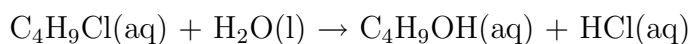

are shown in Table 3.4.4. These are more nearly what one would expect from this experiment.

- Graph the data.
- Estimate the rate of change of the concentration of $\text{C}_4\text{H}_9\text{Cl}$ for each of the times shown.
- Draw a graph of the rate of reaction versus concentration of $\text{C}_4\text{H}_9\text{Cl}$.

Table for Exercise 3.4.4 Data for Ex. 3.4.4.

Time (sec)	0	50	100	150	200	300	400	500	800
$\text{C}[\text{C}_4\text{H}_9\text{Cl}]$ (M)	0.1	0.0905	0.0820	0.0741	0.0671	0.0549	0.0448	0.0368	0.0200

Exercise 3.4.5 Data from Purdue University⁷ for the decrease of the titration marker phenolphthalein (Hln) in the presence of excess base are shown in Table 3.4.5. The data show the concentration of phenolphthalein that was initially at 0.005 M in a solution with 0.61 M OH^- ion.

- Graph the data.
- Estimate the rate of change of the concentration of phenolphthalein (Hln) for each of the times shown.
- Draw a graph of the rate of reaction versus concentration of phenolphthalein.

Table for Exercise 3.4.5 Data for Ex. 3.4.5.

Time (sec)	0	10.5	22.3	35.7	51.1	69.3	91.6	120.4	160.9
Hln (M)	0.005	0.0045	0.0040	0.0035	0.0030	0.0025	0.0020	0.0015	0.0010

Exercise 3.4.6 Data from Michael J. Mombourquette, Queens University, Kingston, Ontario, Canada⁸ for the decrease of CO in the reaction

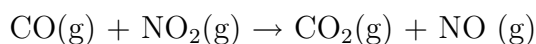

are shown in Table 3.4.6A. and the decrease of N_2O_5 in the reaction

⁶<http://wine1.sb.fsu.edu/chem1046/notes/Kinetics/Rxnrates.htm>

⁷<http://chemed.chem.purdue.edu/genchem/topicreview/bp/ch22/rate.html>

⁸<http://www.chem.queensu.ca/people/faculty/mombourquette/FirstYrChem/kinetics/index.htm>

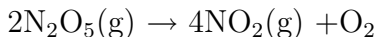

are shown in Table 3.4.6B. Initially, 0.1 g/l of CO was mixed with 0.1 g/l of NO₂.

For each table,

- Graph the data.
- Estimate the rate of change of the concentration of CO or of N₂O₅ for each of the times shown.
- Draw a graph of the rate of reaction versus concentration of reactant.

Table for Exercise 3.4.6 Data for Ex. 3.4.6.

Time (sec)	[CO] g/l
0	0.100
10	0.067
20	0.050
30	0.040

A.

Time (sec)	[N ₂ O ₅]
0	0.0172
10	0.0113
20	0.0084
30	0.0062
40	0.0046
50	0.0035
60	0.0026

B.

3.5 Derivatives of Polynomials, Sum and Constant Factor Rules

We begin a common strategy to find derivatives of functions:

- Use Definition 3.2.2 to find the derivative of a few elementary functions (such as $F(t) = C$, $F(t) = t$, and $F(t) = t^n$). We call these formulas *primary formulas*.
- Use Definition 3.2.2 to prove some rules about derivatives of combinations of functions, called *combination rules*.
- Use the combination rules and primary formulas to compute derivatives of more complex functions.

We are using the symbol t for the independent variable. We could as well use x as in previous sections, but time is a common independent variable in biological models and we wish to use both symbols.

The following are derivative formulas for this section.

Primary formulas: First Set

If C is a number and n is a positive integer and u , v , and F are functions with a common domain, D , then

If for all t , $F(t) = C$ then $F'(t) = 0$ **Constant Rule**

If for all t , $F(t) = t$ then $F'(t) = 1$ **t Rule**

If for all t , $F(t) = t^n$ then $F'(t) = nt^{n-1}$ **t^n Rule**

Combination Rules: First Set

If for all t in D $F(t) = u(t) + v(t)$ then $F'(t) = u'(t) + v'(t)$ **Sum Rule**

If for all t in D $F(t) = C u(t)$ then $F'(t) = C u'(t)$ **Constant Factor Rule**

We use a notation that simplifies the statements of the rules. An example is

If $F(t) = t^4$ then $F'(t) = 4t^3$ is shortened to $[t^4]' = 4t^3$.

More generally

If $F(t) = E(t)$ then $F'(t) = H(t)$ is shortened to $[E(t)]' = H(t)$.

Alternatively, we may use Leibnitz' notation and write

$$\frac{d}{dt} [E(t)] = H(t).$$

The first set of rules may be written,

Derivative Rules: First Set

$$[C]' = 0 \qquad \text{Constant Rule} \qquad (3.27)$$

$$[t]' = 1 \qquad \text{t Rule} \qquad (3.28)$$

$$[t^n]' = n t^{n-1} \qquad \text{t}^n \text{ Rule} \qquad (3.29)$$

$$[u(t) + v(t)]' = u'(t) + v'(t) \qquad \text{Sum Rule} \qquad (3.30)$$

$$[C F(t)]' = C F'(t) \qquad \text{Constant Factor Rule} \qquad (3.31)$$

The short forms depend on your recognizing that C is a constant, t is an independent variable, n is a positive integer, and that u and v are functions with a common domain, and that F is a function.

The distinction between $[C]' = 0$ and $[t]' = 1$ is that the symbol $[\]'$ means rate of change **as t changes**, sometimes said to be **derivative with respect to t** . C denotes a number that does not change with t and therefore its rate of change as t changes is zero. The Leibnitz notation, $\frac{d}{dt}$, is read, 'derivative with respect to t ', and gives a better distinction between these two formulas.

Explore 3.5.1 Write short forms of the first set of derivative rules using the Leibnitz notation, $\frac{d}{dt}$.

Proofs of the Derivative Rules: First Set. You have sufficient experience that you can prove each of these rules using the Definition of Derivative 3.22. We prove the t^n Rule and the Sum Rule and leave the others for you in Exercise 3.5.4.

Explore 3.5.2 The steps of the arguments for the Sum Rule and the Constant Factor Rule will be made apparent if you use Definition of Derivative 3.22 to compute the derivatives of

$$P(t) = t^2 + t^3 \qquad \text{and} \qquad P(t) = 4t^2$$

t^n Rule. Suppose n is a positive integer and a function F is defined by

$$F(t) = t^n \qquad \text{for all numbers } t. \qquad \text{Then} \qquad F'(t) = n t^{n-1}$$

Proof.

$$F'(t) = \lim_{b \rightarrow t} \frac{F(b) - F(t)}{b - t}$$

$$\begin{aligned}
&= \lim_{b \rightarrow t} \frac{b^n - t^n}{b - t} \\
&= \lim_{b \rightarrow t} \frac{(b - t)(b^{n-1} + b^{n-2}t + \dots + bt^{n-2} + t^{n-1})}{b - t} \\
&= \lim_{b \rightarrow t} (b^{n-1} + b^{n-2}t + \dots + bt^{n-2} + t^{n-1}) \\
&= \underbrace{t^{n-1} + t^{n-1} + \dots + t^{n-1} + t^{n-1}}_{n \text{ terms}} \\
&= n t^{n-1}
\end{aligned}$$

We have stated and proved the t^n Rule assuming that n is a positive integer. It is also true for n a negative integer when $t \neq 0$ (Exercise 3.5.5). When t is restricted to being greater than zero, the t^n rule is valid for *every* number n (integer, rational, and irrational). You will prove it for *rational* numbers $\frac{p}{q}$, p and q integers in the Chapter 4, Exercise 4.3.4. Meanwhile, we encourage you to use formulas such as

$$[t^{-5}]' = -5t^{-5-1} = -5t^{-6}, \quad [t^{5/3}]' = \frac{5}{3}t^{(5/3)-1} = \frac{5}{3}t^{2/3}, \quad \text{and even} \quad [t^\pi]' = \pi t^{\pi-1}.$$

Sum Rule. Suppose you and your lab partner are growing two populations of *Vibrio natriegens*, one growing at the rate of 4.32×10^5 cells per minute and the other growing at the rate of 2.19×10^5 cells per minute. It is a fairly easy conclusion that the growth rate of all *V. natriegens* in the two populations is 4.32×10^5 plus $2.19 \times 10^5 = 6.51 \times 10^5$ cells per minute.

It is your experience that rates are additive, and we will include a proof. The proof is needed to distinguish the intuitive for addition from the non-intuitive for multiplication. Many students ‘intuitively think’ that rates are multiplicative, and they are not!

Proof. Suppose u and v are functions with a common domain, D , and for all t in D , $F(t) = u(t) + v(t)$.

$$\begin{aligned}
F'(t) &= \lim_{b \rightarrow t} \frac{F(b) - F(t)}{b - t} \\
&= \lim_{b \rightarrow t} \frac{u(b) + v(b) - (u(t) + v(t))}{b - t} \\
&= \lim_{b \rightarrow t} \frac{u(b) - u(t) + v(b) - v(t)}{b - t} \\
&= \lim_{b \rightarrow t} \frac{u(b) - u(t)}{b - t} + \frac{v(b) - v(t)}{b - t} \\
&= u'(t) + v'(t)
\end{aligned}$$

The sum rule has a companion, the difference rule,

$$[u(t) - v(t)]' = u'(t) - v'(t)$$

that we also call the sum rule. Furthermore,

$$[u(t) + v(t) + w(t)]' = [u(t) + v(t)]' + w'(t) = u'(t) + v'(t) + w'(t).$$

It can be shown by induction that

$$[u_1(t) + u_2(t) + \cdots + u_n(t)]' = u_1'(t) + u_2'(t) + \cdots + u_n'(t)$$

'Sum Rule' encompasses all of these possibilities.

Use of the derivative rules. Using the first set of derivative rules, we can compute the derivative of any polynomial *without explicit reference* to the Definition of Derivative 3.22, as the following example illustrates.

Example 3.5.1 Let $P(t) = 3t^4 - 5t^2 + 2t + 7$. Then

$$\begin{aligned} P'(t) &= [P(t)]' && \text{Notation shift} \\ &= [3t^4 - 5t^2 + 2t + 7]' && \text{Definition of } P \\ &= [3t^4]' - [5t^2]' + [2t]' [7]' && \text{Sum Rule} \\ &= 3[t^4]' - 5[t^2]' + 2[t]' [7]' && \text{Constant Factor Rule} \\ &= 3 \times 4t^3 - 5 \times 2t^1 + 2[t]' [7]' && t^n \text{ Rule} \\ &= 12t^3 - 10t + 2 \times 1 + [7]' && t \text{ Rule} \\ &= 12t^3 - 10t + 2 + 0 && \text{Constant Rule} \end{aligned}$$

Example 3.5.2 It is useful to write some fractions in forms so that the Constant Factor Rule obviously applies. For example

$$P(t) = \frac{t^3}{7} = \frac{1}{7}t^3$$

and to compute P' you may write

$$P'(t) = \left[\frac{t^3}{7} \right]' = \left[\frac{1}{7}t^3 \right]' = \frac{1}{7} [t^3]' = \frac{1}{7} 3t^2 = \frac{3}{7}t^2$$

Similarly

$$P(t) = \frac{8}{3t} = \frac{8}{3} \frac{1}{t}$$

and to compute P' you may write

$$P'(t) = \left[\frac{8}{3t} \right]' = \left[\frac{8}{3} \frac{1}{t} \right]' = \frac{8}{3} \left[\frac{1}{t} \right]' = \frac{8}{3} [t^{-1}]' = \frac{8}{3} ((-1)t^{-1-1}) = -\frac{8}{3} \left(\frac{1}{t^2} \right)$$

Explore 3.5.3 Let $P(t) = 1 + 2t^3/5$. Cite the formulas that justify the steps (i) – (iv).

$$\begin{aligned}
 P'(t) &= \left[1 + 2\frac{t^3}{5}\right]' \\
 &= [1]' + \left[2\frac{t^3}{5}\right]' && (i) \\
 &= 0 + \left[2\frac{t^3}{5}\right]' && (ii) \\
 &= 0 + \left[\frac{2}{5}t^3\right]' \\
 &= 0 + \frac{2}{5} [t^3]' && (iii) \\
 &= 0 + \frac{2}{5} \times 3t^2 && (iv) \\
 &= \frac{6}{5}t^2 && \blacksquare
 \end{aligned}$$

Example 3.5.3 The derivative of a quadratic function is a linear function.

Solution. Suppose $P(t) = at^2 + bt + c$ where a , b , and c are constants. Then

$$\left. \begin{aligned}
 P'(t) &= [at^2 + bt + c]' && (i) \\
 &= [at^2]' + [bt]' + [c]' && (ii) \\
 &= a[t^2]' + b[t]' + [c]' && (iii) \\
 &= a \cdot 2t + b \times 1 + [c]' && (iv) \\
 &= 2at + b + 0 && (v)
 \end{aligned} \right\} \quad (3.32)$$

We see that $P'(t) = 2at + b$ which is a linear function. \blacksquare

3.5.1 Velocity as a derivative.

If $P(t)$ denotes the position of a particle along an axis at time t , then for any time interval $[a, b]$,

$$\frac{P(b) - P(a)}{b - a}$$

is the **average velocity** of the particle during the time interval $[a, b]$. The rate of change of P at $t = a$,

$$\lim_{b \rightarrow a} \frac{P(b) - P(a)}{b - a},$$

is the **velocity** of the particle at time $t = a$.

Example 3.5.4 In baseball, a ‘pop fly’ is hit and the ball leaves the bat traveling vertically at 30 meters per second. How high will the ball go and how much time does the catcher have to get in position to catch it?

Solution. Using a formula from Section 3.6.1, the ball will be at a height $s(t) = -4.9t^2 + 30t$ meters t seconds after it is released, where $s(t)$ is the height above the point of impact with the bat. The velocity, $v(t) = s'(t)$ is

$$[s(t)]' = [-4.9t^2 + 30t]' = -4.9 \cdot 2t + 30 \cdot 1 = -9.8t + 30$$

The ball will be at its highest position when the velocity $v(t) = s'(t) = 0$ (which implies that the ball is not moving and identifies the time at which the ball is at its highest point, is not going up and is not going down).

$$s'(t) = 0 \quad \text{implies} \quad -9.8t + 30 = 0, \quad \text{or} \quad t = \frac{30}{9.8} \approx 3.1 \quad \text{seconds.}$$

The height of the ball at $t = 3.1$ seconds is

$$s(3.1) = -4.9(3.1)^2 + 30 \times 3.1 \approx 45.9 \quad \text{meters}$$

Thus in about 3.1 seconds the ball reaches a height of about 45.9 meters. The catcher will have about 6 seconds to position to catch the ball. Furthermore, at time $t = 6.2$

$$s'(6.2) = -9.8 \times 6.2 + 30 = -30.76 \quad \text{meters/second.}$$

The velocity of the falling ball is ≈ -30.76 m/s when the catcher catches it. Its magnitude will be exactly 30 m/s, the speed at which it left the bat. Why not 30.76? ■

3.5.2 Local Maxima and Local Minima.

Example 3.5.4 illustrates a useful technique that will be expanded in the next chapter: if one is seeking the high point of a graph, it is useful to examine the points at which the derivative of the related function is zero and the tangent is horizontal. However, tangents at local minima are also horizontal, so that knowing the location of a horizontal tangent does not insure that the location is a local maximum – it might be a local minimum or it may be neither a local minimum nor a local maximum!

Shown in Figure 3.21A is the graph of a function and two horizontal tangents to the graph. The horizontal tangent at A marks a local maximum of the graph, the tangent at B marks a local minimum of the graph. A is a ‘local’ maximum because there is an open interval, α , of the domain surrounding the x -coordinate of A and if P is a point of the graph with x -coordinate in α , then P is not above A . But note that there are points of the graph above A . In Figure 3.21B is the graph of $P(t) = t^3$ which has a horizontal tangent at $(0,0)$. The horizontal tangent at $(0,0)$, however, signals neither a local maximum nor a local minimum.

Example 3.5.5 A farmer’s barn is 60 feet long on one side. He has 100 feet of fence and wishes to build a rectangular pen along that side of his barn. What should be the dimensions of the pen to maximize the area?

A diagram of a barn and fence with some important labels, L and W , is shown in Figure 3.22. Because there are 100 feet of fence,

$$2 * W + L = 100$$

The area, A , is

$$A = L W$$

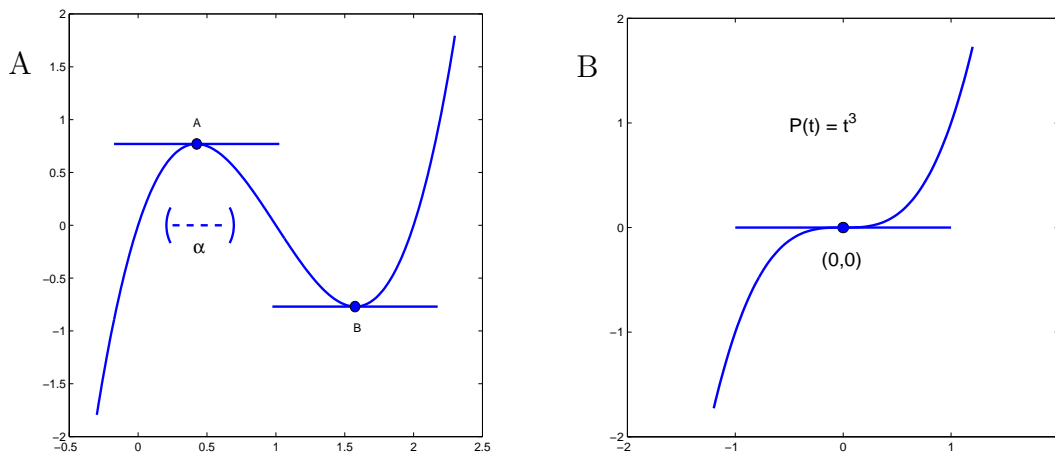

Figure 3.21: A. Graph with a local maximum at A and a local minimum at B . B. Graph of $P(t) = t^3$ that has a horizontal tangent at $(0,0)$; $(0,0)$ is neither a local maximum nor a local minimum of P .

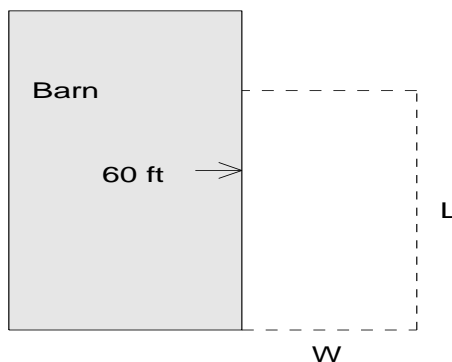

Figure 3.22: Diagram of a barn with adjacent pen bounded by a fence of length 100 feet.

Because $2W + L = 100$,

$$L = 100 - 2W$$

and

$$A = L W = (100 - 2W) W$$

or

$$A = 100W - 2W^2$$

The question becomes now, for what value of W will A be the largest. The graph of A vs W is a parabola with its highest point at the vertex. The tangent to the parabola at the vertex is

horizontal, and we find a value of W for which $A'(W) = 0$.

$$\begin{aligned}
 A'(W) &= [100W - 2W^2]' && (i) \\
 &= [100W]' - [2W^2]' && (ii) \\
 &= 100[W]' - 2[W^2]' && (iii) \\
 &= 100 \times 1 - 2 \times 2W && (iv)
 \end{aligned}
 \left. \vphantom{\begin{aligned} A'(W) &= [100W - 2W^2]' \\ &= [100W]' - [2W^2]' \\ &= 100[W]' - 2[W^2]' \\ &= 100 \times 1 - 2 \times 2W \end{aligned}} \right\} \quad (3.33)$$

The optimum dimensions, W and L , are found by setting $A'(W) = 0$, so that

$$\begin{aligned}
 A'(W) &= 100 - 4W = 0 \\
 W &= 25
 \end{aligned}$$

$$L = 100 - 2W = 50$$

Thus the farmer should build a 25 by 50 foot pen.

Example 3.5.6 This problem is written on the assumption, to our knowledge untested, that spider webs have an optimum size. Seldom are they so small as 1 cm in diameter and seldom are they so large as 2 m in diameter. If they are one cm in diameter, there is a low probability of catching a flying insect; if they are 2 m in diameter they require extra strength to withstand wind and rain. We will examine circular webs, for convenience, and determine the optimum diameter for a web so that it will catch enough insects and not fall down.

Solution. Assume a circular spider web of diameter, d . It is reasonable to assume that the amount of food gathered by the web is proportional to the area, A , of the web. Because $A = \pi d^2/4$, the amount of food gathered is proportional to d^2 . We also *assume* that the energy required to build and maintain a web of area A is proportional to d^3 . (The basic assumption is that the work to build a square centimeter of web increases as the total web area increases because of the need to have stronger fibers. If, for example, the area of the fiber cross-section increases linearly with A and the mesh of the web is constant, the mass of the web increases as d^3 .)

With these assumptions, the net energy, E , available to the spider is of the form

$$\begin{aligned}
 E &= \text{Energy from insects caught} - \text{Energy expended building the web} \\
 &= k_1 d^2 - k_2 d^3
 \end{aligned}$$

where d is measured in centimeters and k_1 and k_2 are proportionality constants.

For illustration we will assume that $k_1 = 0.01$ and $k_2 = 0.0001$. A graph of $E(d) = 0.01d^2 - 0.0001d^3$ is shown in Figure 3.23 where it can be seen that there are two points, A and B , at which the graph has horizontal tangents. We find where the derivative is zero to locate A and B .

$$\begin{aligned}
 E'(d) &= [0.01d^2 - 0.0001d^3]' && (i) \\
 &= [0.01d^2]' - [0.0001d^3]' && (ii) \\
 &= 0.01[d^2]' - 0.0001[d^3]' && (iii) \\
 &= 0.01 \times 2d - 0.0001 \times 3d^2 && (iv) \\
 &= 0.02d - 0.0003d^2
 \end{aligned}
 \left. \vphantom{\begin{aligned} E'(d) &= [0.01d^2 - 0.0001d^3]' \\ &= [0.01d^2]' - [0.0001d^3]' \\ &= 0.01[d^2]' - 0.0001[d^3]' \\ &= 0.01 \times 2d - 0.0001 \times 3d^2 \\ &= 0.02d - 0.0003d^2 \end{aligned}} \right\} \quad (3.34)$$

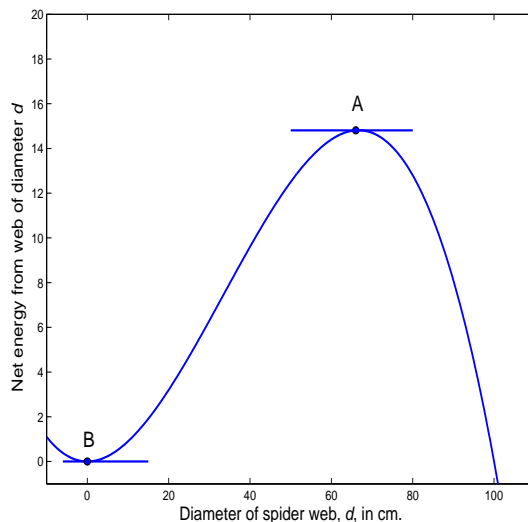

Figure 3.23: Graph of $E(d) = 0.01d^2 - 0.0001d^3$ representative of the energy gain from a spider web of diameter d cm. There is a local maximum at A and a local minimum at B .

Then $E'(d) = 0$ yields

$$\begin{aligned} 0.02d - 0.0003d^2 &= 0 \\ d(0.02 - 0.0003d) &= 0 \\ d &= 0 \quad \text{or} \quad d = 0.02/0.0003 \doteq 66.7 \text{ cm} \end{aligned}$$

The value $d = 0$ locates the local minimum at B and has an obvious interpretation: if there is no web there is no energy gain. At $d = 66.7$ cm, $E(d) = 14.8$ (units unspecified) suggests that a positive net energy will accrue with a web of diameter 66.7 cm and that weaving a web of 66.7 cm diameter is the optimum strategy for the spider. Note that if our model and its parameters are correct we have determined in a rather short time what it took spiders many generations to work out. At the very least we could have moved the spiders ahead several generations with our model. ■

Exercises for Section 3.5, Derivatives of Polynomials, Sum and Constant Factor Rules.

Exercise 3.5.1 Use Definition of the Derivative 3.22 to compute $P'(t)$ for

- | | | |
|--------------------------|-------------------------|----------------------------|
| (a) $P(t) = 1 + t^2$ | (b) $P(t) = t - t^2$ | (c) $P(t) = t^2 - t$ |
| (d) $P(t) = 5t^2$ | (e) $P(t) = 5 \times 3$ | (f) $P(t) = 1 + 5t^2$ |
| (g) $P(t) = 1 + t + t^2$ | (h) $P(t) = 2t + 3t^2$ | (i) $P(t) = 5 + 3t - 2t^2$ |

Exercise 3.5.2 Suppose u and v are functions with a common domain and $P = u - v$. Write $P(t) = u(t) + (-1)v(t)$ and use the Sum and Constant Factor rules to show that $P'(t) = u'(t) - v'(t)$.

Exercise 3.5.3 Provide reasons for the steps (i) – (v) in Equations 3.32 use to show that the derivatives of quadratic functions are linear functions.

Exercise 3.5.4 a. Prove Equation 3.27, $[C]' = 0$.

b. Prove Equation 3.28, $[t]' = 1$.

c. Prove Equation 3.31, $[CF(t)]' = C [F(t)]'$.

Exercise 3.5.5 Suppose m is a positive integer and $u(t) = t^{-m} = 1/t^m$ for $t \neq 0$. Show that $u'(t) = -mt^{-m-1}$, thus proving the t^n rule for negative integers. Begin your argument with

$$\begin{aligned} u'(t) &= \lim_{b \rightarrow t} \frac{\frac{1}{b^m} - \frac{1}{t^m}}{b - t} \\ &= \lim_{b \rightarrow t} \frac{t^m - b^m}{b^m t^m} \times \frac{1}{b - t} \end{aligned}$$

Exercise 3.5.6 Provide reasons for the steps (i) – (iv) in Equations 3.33 used to find the optimum dimensions of a lot adjacent to a barn.

Exercise 3.5.7 A farmer's barn is 60 feet long on one side. He has 120 feet of fence and wishes to build a rectangular pen along that side of his barn. What should be the dimensions of the pen to maximize the the area of the pen?

Exercise 3.5.8 A farmer's barn is 60 feet long on one side. He has 150 feet of fence and wishes to build two adjacent rectangular pens of equal area along that side of his barn. What should be the arrangement and dimensions of the pen to maximize the sum of the areas of the two pens?

Exercise 3.5.9 A farmer's barn is 60 feet long on one side. He has 150 feet of fence and wishes to build two adjacent rectangular pens of equal area along that side of his barn. What should be the arrangement and dimensions of the pen to maximize the sum of the areas of the two pens?

Exercise 3.5.10 A farmer's barn is 60 feet long on one side. He has 280 feet of fence and wishes to build two adjacent rectangular pens of equal area along that side of his barn. What should be the arrangement and dimensions of the pen to maximize the sum of the areas of the two pens?

Exercise 3.5.11 A farmer's barn is 60 feet long on one side. He wishes to build a rectangular pen of area 800 square feet along that side of his barn. What should be the dimension of the pen to minimize the amount of fence used?

Exercise 3.5.12 Show that the derivatives of cubic functions are quadratic functions.

Exercise 3.5.13 Probably baseball statistics should be discussed in British units rather than metric units. Professional pitchers throw fast balls in the range of 90+ miles per hour. Suppose the pop fly ball leaves the bat traveling 60 miles per hour (88 feet/sec), in which case the height of the ball in feet will be $s(t) = -16t^2 + 88t$ feet above the bat, t seconds after the batter hits the ball. How high will the ball go, and how long will the catcher have to position to catch it? How fast is the ball falling when the catcher catches it?

Exercise 3.5.14 A squirrel falls from a tree from a height of 10 meters above the ground. At time t seconds after it slips from the tree, the squirrel is a distance $s(t) = 10 - 4.9t^2$ meters above the ground. How fast is the squirrel falling when it hits the ground?

Exercise 3.5.15 What is the optimum radius of the trachea when coughing? The objective is for the flow of air to create a strong force outward in the throat to clear it.

For this problem you should perform the following experiment.

Hold your hand about 10 cm from your mouth and blow on it (a) with your lips compressed almost closed but with a small stream of air escaping, (b) with your mouth wide open, and (c) with your lips adjusted to create the largest force on your hand. With (a) your lips almost closed there is a high pressure causing rapid air flow but a small stream of air and little force. With (b) your mouth wide open there is a large stream of air but with little pressure so that air flow is slow. The largest force (c) is created with an intermediate opening of your lips where there is a notable pressure and rapid flow of substantial volume of air.

Let R be the normal radius of the trachea and $r < R$ be the tracheal radius when coughing. Assume that the velocity of air flow through the trachea is proportional to pressure difference across the trachea and that the pressure difference is proportional to $R - r$, the constriction of the trachea. Assume that the mass of air flow is proportional to the area of the trachea (πr^2). Finally, the momentum, M , of the air flow is mass times velocity:

$$M = k r^2(R - r)$$

What value of r , $0 < r < R$, maximizes M ?

Exercise 3.5.16 Cite formulas that justify the steps (i) – (iv) in Equations 3.34 for the analysis of the spider web.

Exercise 3.5.17 Let $P(t) = -3 + 5t - 2t^2$. Cite the formulas that justify steps (i) – (vi) below:

$$\begin{aligned} P'(t) &= [-3 + 5t + (-2)t^2]' && (i) \\ &= [-3]' + [5t]' + [(-2)t^2]' && (ii) \\ &= 0 + [5 \times t]' + [(-2)t^2]' && (iii) \\ &= 0 + 5[t]' + (-2)[t^2]' && (iv) \\ &= 0 + 5 \times 1 + (-2)[t^2]' && (v) \\ &= 0 + 5 \times 1 + (-2) \times 2t && (vi) \\ &= 5 - 4t \end{aligned}$$

Exercise 3.5.18 Compute the derivatives of the following polynomials as in the previous exercises.

Use only one rule for each step written, and write the name of the rule used for each step.

$$\begin{array}{ll} \text{a. } P(t) = 15t^2 - 32t^6 & \text{c. } P(t) = \frac{t^4}{4} + \frac{t^3}{3} \\ \text{b. } P(t) = 1 + t + t^2 + t^3 & \text{d. } P(t) = (1 + t^2)^2 \\ \text{e. } P(t) = 31t^{52} - 82t^{241} + \pi t^{314} & \text{f. } P(t) = 2^5 + 17t^5 \\ \text{g. } P(t) = \sqrt{2} - \frac{t^7}{427} + 18t^{35} & \text{h. } P(t) = 17^3 - \frac{t^{23}}{690} + 5t^{705} \end{array}$$

Exercise 3.5.19 Find values of t for which $P'(t) = 0$ for:

$$\begin{array}{ll} \text{a. } P(t) = t^2 - 10t + 35 & \text{c. } P(t) = 5t^2 - t + 1 \\ \text{b. } P(t) = t^3 - 3t + 8 & \text{d. } P(t) = t^3 - 6t^2 + 9t + 7 \\ \text{e. } P(t) = 7t^4 - 56t^2 + 8 & \text{f. } P(t) = t + \frac{1}{t} \quad t > 0 \\ \text{g. } P(t) = \frac{t}{2} + \frac{2}{t} & \text{h. } P(t) = \frac{t^3}{3} - t^2 + t \end{array}$$

Exercise 3.5.20 Suppose that in the problem of Example 3.5.6, the work of building a web is proportional to d^4 , the fourth power of the diameter, d . Then the energy available to the spider is

$$E = k_1 d^2 - k_2 d^4$$

Assume that $k_1 = 0.01$ and $k_2 = 0.000001$.

- Draw a graph of $E = 0.01 d^2 - 0.000001 d^4$ for $-10 \leq d \leq 110$.
- Find $E'(d)$ for $E(d) = 0.01 d^2 - 0.000001 d^4$.
- Find two numbers, d , for which $E'(d) = 0$.
- Find the highest point of the graph between $d = 0$ and $d = 100$.

Exercise 3.5.21 Consider a territorial bird that harvests only in its defended territory (assumed to be circular in shape). The amount of food available can be assumed to be proportional to the area of the territory and therefore proportional to d^2 , the square of the diameter of the territory. Assume that the food gathered is proportional to the amount of food available times the time spent gathering food. Let the unit of time be one day, and suppose the amount of time spent defending the territory is proportional to the length of the territory boundary and therefore equal to $k \times d$ for some constant, k . Then $1 - k d$ is the amount of time available to gather food, and the amount, F of food gathered will be

$$F = k_2 d^2 (1 - k d)$$

Find the value of d that will maximize the amount of food gathered.

3.6 The second derivative and higher order derivatives.

You may read or hear statements such as “the rate of population growth is decreasing”, or “the rate of inflation is increasing”, or the velocity of the particle is increasing.” In each case the underlying quantity is a rate and *its* rate of change is important.

Definition 3.6.1 The second derivative. *The second derivative of a function, P , is the derivative of the derivative of P , or the derivative of P' .*

The second derivative of P may be denoted by

$$P'', \quad P''(t), \quad \frac{d^2P}{dt^2}, \quad \ddot{P}, \quad \ddot{P}(t), \quad P^{(2)}, \quad P^{(2)}(t), \quad \text{or} \quad D_t^2P(t)$$

Geometry of the first and second derivatives. That a function, P is *increasing* on an interval $[a, b]$ means that

$$\text{if } s \text{ and } t \text{ are in } [a, b] \text{ and } s < t \quad \text{then} \quad P(s) < P(t)$$

It should be fairly intuitive that if the first derivative of a function, P , is positive throughout $[a, b]$, then P is increasing on $[a, b]$. Both graphs in Figure 3.24 have positive first derivatives and are increasing. The graphs also illustrate the geometry of the second derivative. In Figure 3.24A P' is increasing ($P'(s) < P'(t)$). P has a *positive second derivative* ($P'' > 0$) and the graph of P is *concave upward*. In Figure 3.24B, P' is decreasing ($P'(s) > P'(t)$). P has a *negative second derivative* ($P'' < 0$) and the graph of P is concave downward. We will expand on this interpretation in Chapters 8 and 12.

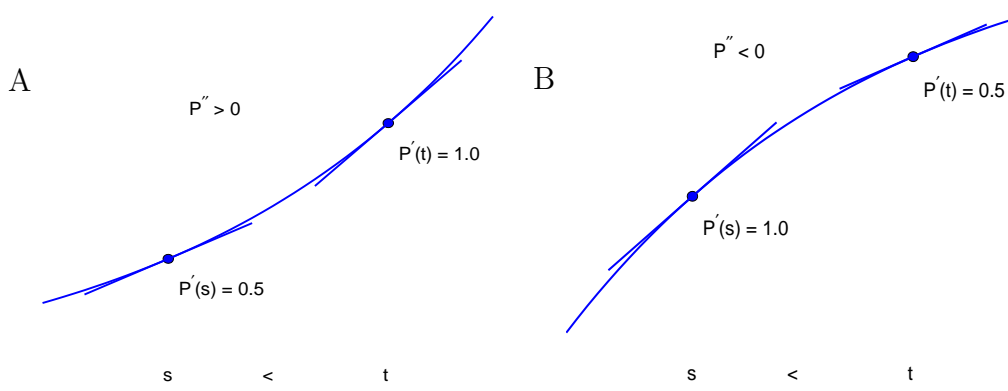

Figure 3.24: A. Graph of a function with a positive second derivative; it is concave up. B. Graph of a function with a negative second derivative; it is concave down.

The higher order derivatives are a natural extension of the transition from the derivative to the second derivative. The third derivative is the derivative of the second derivative; the fourth derivative is the derivative of the third derivative; and the process continues. In this language, the

derivative of P is called the first derivative of P (and sometimes P itself is called the zero-order derivative of P).

Definition 3.6.2 Inductive definition of higher order derivatives. *The derivative of a function, P , is the order 1 derivative of P . For n an integer greater than 1, the order n derivative of P is the derivative of the order $n - 1$ derivative of P .*

The third order derivative of P may be denoted by

$$P''', \quad P'''(t), \quad \frac{d^3 P}{dt^3}, \quad P^{(3)}, \quad P^{(3)}(t), \quad \text{or} \quad D_t^3 P(t)$$

For $n > 3$ the n th order derivative of P may be denoted by

$$P^{(n)}, \quad P^{(n)}(t), \quad \frac{d^n P}{dt^n}, \quad \text{or} \quad D_t^n P(t)$$

If $P(t) = \mu t + \beta$ is a linear function, then $p'(t) = \mu$, is a constant function, and $P''(t) = [\mu]' = 0$ is the zero function. A similar pattern occurs with quadratic polynomials. Suppose $P(t) = at^2 + bt + c$ is a quadratic polynomial. Then

$$\begin{aligned} P'(t) &= [at^2 + bt + c]' \\ &= 2at + b && P'(t) \text{ is a linear function.} \\ \\ P''(t) &= [2at + b]' \\ &= 2a && P''(t) \text{ is a constant function.} \\ \\ P'''(t) &= [2a]' \\ &= 0 && P'''(t) \text{ is the zero function.} \end{aligned} \tag{3.35}$$

Explore 3.6.1 Suppose $P(t) = a + bt + ct^2 + dt^3$ is a cubic polynomial. Show that P' is a quadratic polynomial, P'' is a linear function, P''' is a constant function, and $P^{(4)}$ is the zero function.

If $S(t)$ is the position of a particle along an axis at time t , then $s'(t)$ is the velocity of the particle and the rate of change of velocity, $s''(t)$, is called the *acceleration* of the particle. Sometimes when $s''(t)$ is negative the word *deceleration* is used to describe the motion of the particle. The word acceleration is used to describe second derivatives in other contexts. An accelerating economy is one in which the rate of increase of the gross national product is increasing.

Example 3.6.1 Shown in Figure 3.25A is the graph of the logistic function, $L(t)$, first shown in Figure 3.15. Some tangents are drawn on the graph of L . The slope at b is greater than the slope at a ; the slope, $L'(t)$, is increasing on the interval to the left of the point marked, I =Inflection Point.

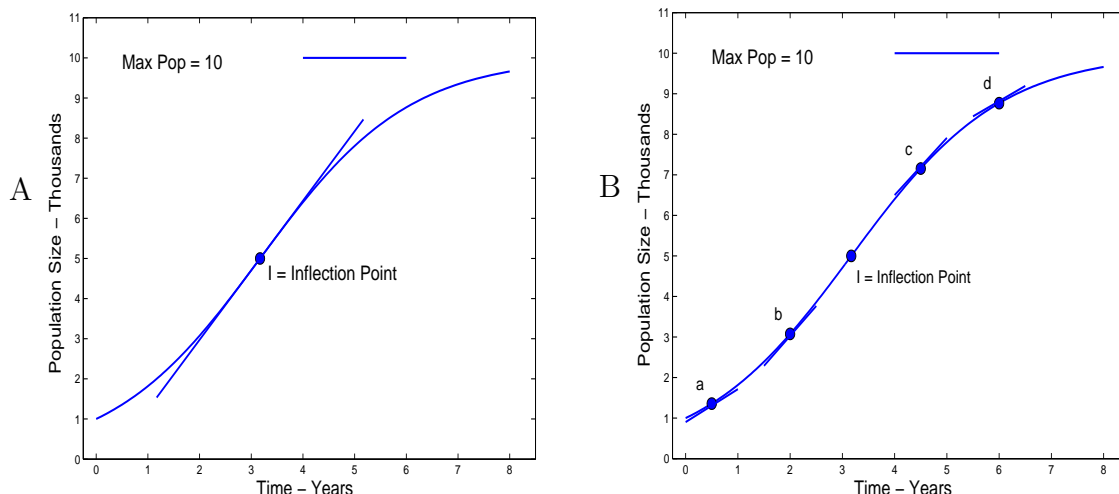

Figure 3.25: A. The graph of a logistic equation and an inflection point I . B. The same graph with tangent segments. The slope of the segment at a is less than the slope at b . The slope at c is greater than the slope at d .

Explore 3.6.2 Do this.

- The slopes of L at b and d are approximately 1.5 and 0.75. Estimate the slopes at a and c . Confirm that the slope at a is less than the slope at b and that the slope at c is greater than the slope at d .
- Let t_I be the time of the inflection point I . Argue that $L''(t) > 0$ on $[0, t_I]$.
- Argue that $L''(t) < 0$ for $t > t_I$.
- Argue that $L''(t_I) = 0$.
- On what interval is the graph of L concave downward? ■

The tangent at the inflection point is shown in Figure 3.25B, and it is interesting that the tangent crosses the curve at I . The slope of that tangent $\doteq 1.733$, and is the largest of the slopes of all of the tangents. The maximum population growth rate occurs at t_I and is approximately 1733 individuals per year.

Explore 3.6.3 Danger: Obnubilation Zone. You have to think about this. Suppose the population represented by the logistic curve in Figure 3.25 is a natural population such as deer, fish, geese or shrimp, and suppose you are responsible for setting the size of harvest each year. What is your strategy?

Argue with a friend about this. You should observe that the population size at the inflection point, I , is 5 which is one-half the maximum supportable population of 10. You should discuss the fact that variable weather, disease and other factors may disrupt the ideal of logistic growth. You should discuss how much harvest you could have if you maintained the population at points a , b , c or d in Figure 3.25A. ■

■

3.6.1 Falling objects.

We describe the position, $s(t)$, of an object falling in the earth's gravity field near the Earth's surface t seconds after release. We assume that the velocity of the object at time of release is v_0 and the height of the object above the earth (or some reference point) at time of release is s_0 .

Gravity near the Earth's surface is constant, equal to $g = -980 \text{ cm/sec}^2$. We write the

Mathematical Model 3.6.1 Free falling object. The acceleration of a free falling object near the Earth's surface is the acceleration of gravity, g .

Because $s''(t)$ is the acceleration of the falling object, we write

$$s''(t) = g.$$

Now, s'' is a constant and is the derivative of s' . The derivative of a linear function, $P(t) = at + b$, is a constant ($P'(t) = a$). We invoke some **advertising logic**⁹ and guess that $s'(t)$ is a linear function (proved in Chapter 10).

$$s'(t) = gt + b \quad \text{Bolt out of Chapter 10.}$$

Because $s'(0) = v_0$ is assumed known, and $s'(0) = g \cdot 0 + b = b$, we write

$$s'(t) = gt + s_0$$

Using equally compelling logic, because the derivative of a quadratic function, $P(t) = at^2 + bt + c$, is a linear function ($P'(t) = 2at + b$), and because s' is a linear function and $s(0) = s_0$, we write

$$s(t) = \frac{g}{2}t^2 + v_0t + s_0 \tag{3.36}$$

Example 3.6.2 Students measured height *vs* time of a falling bean bag using a Texas Instruments Calculator Based Laboratory Motion Detector, and the data are shown in Figure 3.26A. Average velocities were computed between data points and plotted against the midpoints of the data intervals in Figure 3.26B. Mid-time is $(\text{Time}_{i+1} + \text{Time}_i)/2$ and Ave. Vel. is $(\text{Height}_{i+1} - \text{Height}_i)/(\text{Time}_{i+1} - \text{Time}_i)$.

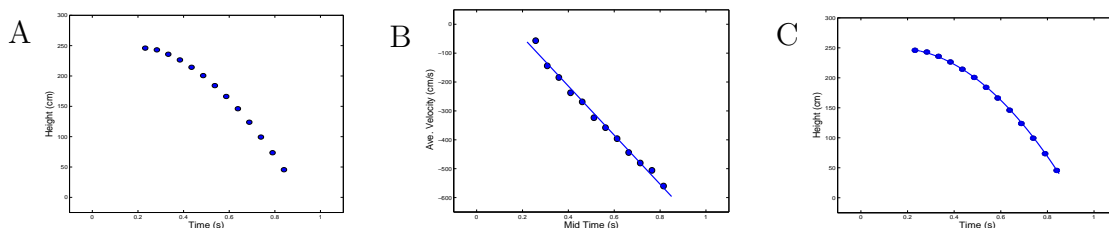

Figure 3.26: Graph of height *vs* time and velocity *vs* time of a falling bean bag.

An equation of the line fit by least squares to the graph of Average Velocity *vs* Midpoint of time interval is

$$v_{\text{ave}} = -849t_{\text{mid}} + 126 \quad \text{cm/s.}$$

⁹Advertising Logic: A tall, muscular, rugged man drives a Dodge Ram. If you buy a Dodge Ram, you will be a tall muscular, rugged man.

If we assume a continuous model based on this data, we have

$$s'(t) = -849t + 126, \quad s(t) = \frac{-849}{2}t^2 + 126t + s_0 \quad \text{cm}$$

From Figure 3.26, the height of the first point is about 240. We write

$$s(t) = \frac{-849}{2}t^2 + 126t + 240 \quad \text{cm}$$

The graph of s along with the original data is shown in Figure 3.26C. The match is good. Instead of g -980 cm/s^2 that applies to objects falling in a vacuum we have acceleration of the bean bag in air to be -849 cm/sec^2 . ■

Exercises for Section 3.6, The second derivative and higher order derivatives.

Exercise 3.6.1 Compute P' , P'' and P''' for the following functions.

- | | | |
|-----------------|---------------------|---------------------|
| a. $P(t) = 17$ | b. $P(t) = t$ | c. $P(t) = t^2$ |
| d. $P(t) = t^3$ | e. $P(t) = t^{1/2}$ | f. $P(t) = t^{-1}$ |
| g. $P(t) = t^8$ | h. $P(t) = t^{125}$ | i. $P(t) = t^{5/2}$ |

Exercise 3.6.2 Find the acceleration of a particle at time t whose position, $P(t)$, on an axis is described by

- | | |
|-------------------------------|---|
| a. $P(t) = 15$ | b. $P(t) = 5t + 7$ |
| c. $P(t) = -4.9t^2 + 22t + 5$ | d. $P(t) = t - \frac{t^3}{6} + \frac{t^5}{120}$ |

Exercise 3.6.3 Compute P' , P'' and P''' and $P^{(4)}$ for $P(t) = a + bt + ct^2 + dt^3$.

Exercise 3.6.4 For each figure in Exercise Figure 3.6.4, state whether:

- P is increasing or decreasing?
- P' is positive or negative?
- P' is increasing or decreasing?
- $P''(a)$ positive or negative?
- The graph of P is concave up or concave down

Figure for Exercise 3.6.6 Graph of a function P with a maximum at $(a, P(a))$. See Exercise 3.6.6.

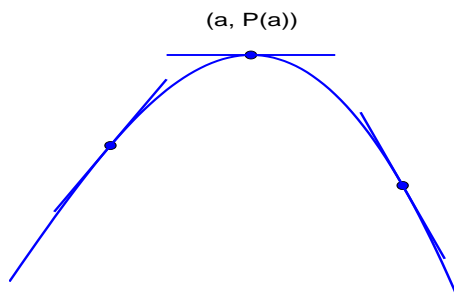

Exercise 3.6.7 Show that $A(t)$ of Equation 3.26,

$$A(t) = \left(\frac{K}{2}t + 2\right)^2 \quad t \geq 0,$$

satisfies Equation 3.25,

$$A(0) = 4 \quad A'(t) = K\sqrt{A(t)} \quad t \geq 0$$

You will need to compute $A'(t)$ and to do so expand

$$A(t) = \left(\frac{K}{2}t + 2\right)^2 \quad \text{to} \quad A(t) = \frac{K^2}{4}t^2 + Kt + 4$$

and show that

$$A'(t) = K\left(\frac{K}{2}t + 2\right) = K\sqrt{A(t)}.$$

Exercise 3.6.8 Show that for $s(t) = \frac{g}{2}t^2 + v_0t + \gamma$, $s'(t) = gt + v_0$.

Exercise 3.6.9 Evaluate γ if

a. $s(t) = 5t^2 + \gamma$ and $s(0) = 15$

b. $s(t) = -8t^2 + 12t + \gamma$ and $s(0) = 11$

c. $s(t) = -8t^2 + 12t + \gamma$ and $s(1) = 11$

d. $s(t) = -\frac{849}{2}t^2 + 126t + \gamma$ and $s(0.232) = 245.9$

Exercise 3.6.10 Show that

- a. $P(t) = 5t + 3$ satisfies $P(0) = 3$ and $P'(t) = 5$
- b. $P(t) = 8t + 2$ satisfies $P(0) = 2$ and $P'(t) = 8$
- c. $P(t) = t^2 + 3t + 7$ satisfies $P(0) = 7$ and $P'(t) = 2t + 3$
- d. $P(t) = -2t^2 + 5t + 8$ satisfies $P(0) = 8$ and $P'(t) = -4t + 5$
- e. $P(t) = (3t + 4)^2$ satisfies $P(0) = 16$ and $P'(t) = 6\sqrt{P(t)}$
- f. $P(t) = (5t + 1)^2$ satisfies $P(0) = 1$ and $P'(t) = 10\sqrt{P(t)}$
- g. $P(t) = (1 - 2t)^{-1}$ satisfies $P(0) = 1$ and $P'(t) = 2(P(t))^2$
- h. $P(t) = \frac{5}{1 - 15t}$ satisfies $P(0) = 5$ and $P'(t) = 3(P(t))^2$
- i. $P(t) = (6t + 9)^{1/2}$ satisfies $P(0) = 3$ and $P'(t) = 3/P(t)$
- j. $P(t) = (4t + 4)^{1/2}$ satisfies $P(0) = 2$ and $P'(t) = 2/P(t)$
- k. $P(t) = (4t + 4)^{3/2}$ satisfies $P(0) = 8$ and $P'(t) = 6\sqrt[3]{P(t)}$

For parts g - k, use the Definition of Derivative 3.2.2 to compute P' .

Exercise 3.6.11 Add the equations,

$$H_2 - H_1 = \frac{-849}{2} (t_2^2 - t_1^2) + 126 (t_2 - t_1)$$

$$H_3 - H_2 = \frac{-849}{2} (t_3^2 - t_2^2) + 126 (t_3 - t_2)$$

$$\vdots \quad \vdots \quad \vdots$$

$$H_n - H_{n-1} = \frac{-849}{2} (t_n^2 - t_{n-1}^2) + 126 (t_n - t_{n-1}).$$

to obtain

$$H_n - H_1 = \frac{-849}{2} (t_n^2 - t_1^2) + 126 (t_n - t_1).$$

Exercise 3.6.12 In a chemical reaction of the form

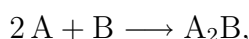

where the reaction does not involve intermediate compounds, the reaction rate is proportional to $[A]^2 [B]$ where $[A]$ and $[B]$ denote, respectively, the concentrations of the components A and B. Let a and b denote $[A]$ and $[B]$, respectively, and assume that $[B]$ is much greater than $[A]$ so that $(b(t) \gg a(t))$. The rate at which a changes may be written

$$a'(t) = -k(a(t))^2 b(t) = -K(a(t))^2$$

We have assumed that $b(t)$ is (almost) constant because $[A]$ is the limiting concentration of the reaction.

Let

$$a(t) = \frac{a_0}{1 - a_0 K t}.$$

Show that $a(0) = a_0$.

Use the Definition of Derivative 3.22,

$$a'(t) = \lim_{b \rightarrow t} \frac{a(b) - a(t)}{b - t}$$

to compute $a'(t)$. Then compute $(a(t))^2$ and show that

$$a'(t) = -K (a(t))^2$$

Exercise 3.6.13 Show that for any quadratic function, $Q(t) = a + bt + ct^2$ (a , b and c are constants), and any interval, $[u, v]$, the average rate of change of Q on $[u, v]$ is equal to the rate of change of Q at the midpoint, $(u + v)/2$, of $[u, v]$.

3.7 Left and right limits and derivatives; limits involving infinity.

Suppose F is a function defined for all x . We give meaning to the following symbols.

$$\lim_{x \rightarrow a^-} F(x) \quad \text{and} \quad F'^-(a).$$

Having done so, we ask you to define

$$\lim_{x \rightarrow a^+} F(x), \quad \text{and} \quad F'^+(a).$$

Next we will define limits involving infinity,

$$\lim_{x \rightarrow \infty} F(x) \quad \text{and} \quad \lim_{x \rightarrow a^-} F(x) = \infty,$$

and ask you to define

$$\lim_{x \rightarrow -\infty} F(x) \quad \text{and} \quad \lim_{x \rightarrow a^+} F(x) = \infty.$$

In reading the following two definitions, it will be helpful to study the graphs in Figure 3.27 and assume $a = 3$.

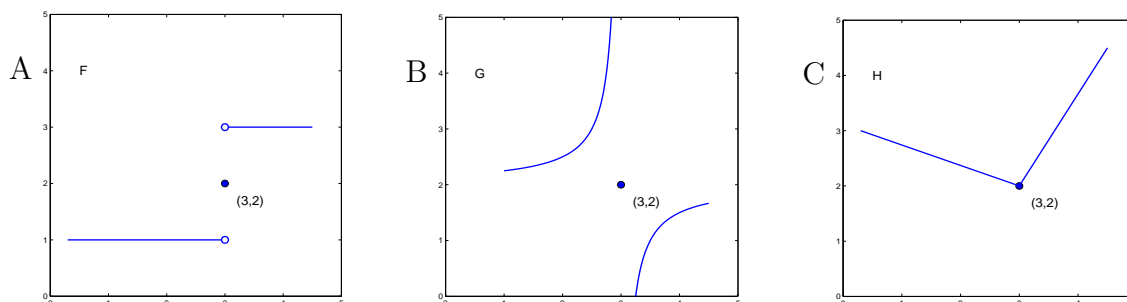

Figure 3.27: Graphs of functions F , G , and H that illustrate Definitions 3.7.1 and 3.7.2.

Definition 3.7.1 *Left hand limit and derivative.* Suppose F is a function defined for all numbers x except perhaps for a number a and L is a number.

The statement that $\lim_{x \rightarrow a^-} F(x) = L$ means that

if ϵ is a positive number there is a positive number δ such that if x is in the domain of F and $a - \delta < x < a$, then $|F(x) - L| < \epsilon$.

If F is defined at a , then $F'^-(a)$ is defined by

$$F'^-(a) = \lim_{x \rightarrow a^-} \frac{F(x) - F(a)}{x - a}. \quad (3.37)$$

For convenience, in the definitions we have assumed that F is defined for all numbers except perhaps a ; in Definition 3.7.1, for example, it would be sufficient to assume that for every number b less than a , the domain of F contains a number between b and a . The condition $a - \delta < x < a$ restricts x to being 'to the left' of a ($x < a$) and within δ of a . In Figure 3.27A, $\lim_{x \rightarrow 3^-} F(x) = 1$. In Figure 3.27C, $H'^-(3) = -1/3$. This may help resolve some dispute as to whether H has a tangent at $(3, 2)$ that was mentioned early in this chapter, Explore 3.1.2.

Definition 3.7.2 *Limits involving infinity.* Suppose F is a function defined for all numbers x except perhaps for a number a and L is a number.

The statement that $\lim_{x \rightarrow \infty} F(x) = L$ means that

if ϵ is a positive number there is a number M so that if $x > M$, $|F(x) - L| < \epsilon$.

The half-line $y = L$ for $x > 0$ is said to be a *horizontal asymptote* of F .

The statement that $\lim_{x \rightarrow a} F(x) = \infty$ means that

if M is a number there is a positive number δ so that if $0 < |a - x| < \delta$, $F(x) > M$.

In Figure 3.27B, $\lim_{x \rightarrow \infty} G(x) = 2$, and $\lim_{x \rightarrow 3} G(x)$ does not exist. However, $\lim_{x \rightarrow 3^-} G(x) = \infty$

Explore 3.7.1 Refer to Figure 3.27. For each part below, either evaluate the expression or explain

why it is not defined.

- | | | | | | |
|----|------------------------------------|----|-------------------------------------|----|---------------------------------------|
| a. | $\lim_{x \rightarrow 3^+} F(x)$ | b. | $\lim_{x \rightarrow 3} F(x)$ | c. | $\lim_{x \rightarrow 3^+} G(x)$ |
| d. | $F'^-(3)$ | e. | $H'^+(3)$ | f. | $H'(3)$ |
| g. | $\lim_{x \rightarrow \infty} F(x)$ | h. | $\lim_{x \rightarrow -\infty} F(x)$ | i. | $\lim_{x \rightarrow -\infty} H(x)$ ■ |

Explore 3.7.2 Write definitions for:

- | | | | | | |
|----|---|----|-----------|----|---|
| a. | $\lim_{x \rightarrow a^+} F(x) = L$ | b. | $F'^+(a)$ | c. | $\lim_{x \rightarrow -\infty} F(x) = L$ |
| d. | $\lim_{x \rightarrow a^+} F(x) = -\infty$ | | ■ | | |

Explore 3.7.3 Attention: Solving this problem may require a significant amount of thought.

We say that $\lim_{x \rightarrow a^-} F(x)$ exists if either

$$\lim_{x \rightarrow a^-} F(x) = -\infty, \quad \lim_{x \rightarrow a^-} F(x) = \infty, \quad \text{or for some number } L \quad \lim_{x \rightarrow a^-} F(x) = L.$$

Is there a function, F , defined for all numbers x such that

$$\lim_{x \rightarrow 1^-} F(x) \quad \text{does not exist.} \quad \blacksquare$$

Proof of the following theorem is only technical and is omitted.

Theorem 3.7.1 Suppose (p, q) an open interval containing a number a and F is a function defined on (p, q) excepts perhaps at a and L is a number.

$$\lim_{x \rightarrow a} F(x) = L \quad \text{if and only if both} \quad \lim_{x \rightarrow a^-} F(x) = L \quad \text{and} \quad \lim_{x \rightarrow a^+} F(x) = L. \quad (3.38)$$

Furthermore, if F is defined at a

$$F'(a) \quad \text{exists if and only if} \quad F'^-(a) = F'^+(a), \quad \text{in which case} \quad F'(a) = F'^-(a). \quad (3.39)$$

Exercises for Section 3.7 Left and right limits and derivatives; limits involving infinity.

Exercise 3.7.1 For each of the graphs in Figure 3.7.1 of a function, F , answer the questions or assert that there is no answer available.

1. What does $F(t)$ approach as t approaches 3?
2. What does $F(t)$ approach as t approaches 3^- ?
3. What does $F(t)$ approach as t approaches 3^+ ?
4. What is $F(3)$?
5. Use the limit symbol to express answers to a. - c.

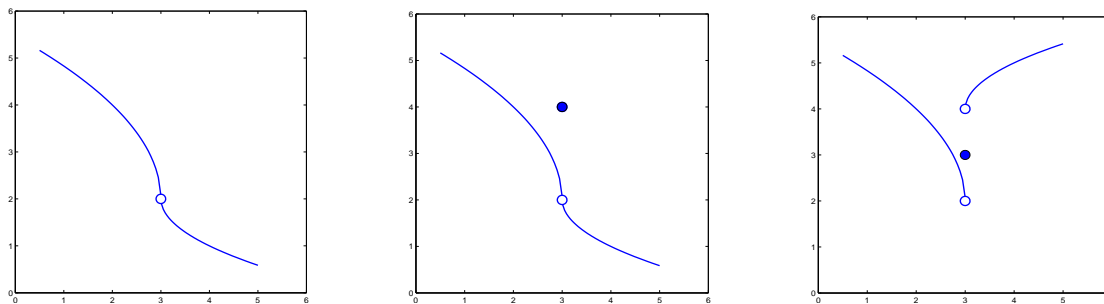
Figure for Exercise 3.7.1 Graphs of three functions for Exercise 3.7.1.

Exercise 3.7.2 Let functions D , E , F , G , and H be defined by

$$\begin{aligned}
 D(x) &= |x| && \text{for all } x \\
 E(x) &= \begin{cases} -1 & \text{for } x < 0 \\ 0 & \text{for } x = 0 \\ 1 & \text{for } 0 < x \end{cases} \\
 F(x) &= \begin{cases} x^2 & \text{for } x < 0 \\ \sqrt{x} & \text{for } x \geq 0 \end{cases} \\
 G(x) &= \begin{cases} 1 & \text{for } x \neq 0 \\ 2 & \text{for } x = 0 \end{cases} \\
 H(x) &= \begin{cases} x & \text{for } x < 0 \\ x^2 & \text{for } x \geq 0 \end{cases}
 \end{aligned}$$

A. Sketch the graphs of D , E , F , G , and H .

B. Let K be either of D , E , F , G , or H . Evaluate the limits or show that they do not exist.

$$\begin{array}{lll}
 \text{a. } \lim_{x \rightarrow 0^-} K(x) & \text{b. } \lim_{x \rightarrow 0^+} K(x) & \text{c. } \lim_{x \rightarrow 0} K(x) \\
 \text{d. } K'^-(0) & \text{e. } K'^+(0) & \text{f. } K'(0)
 \end{array}$$

Exercise 3.7.3 Define the term 'tangent from the left'. (We assume you would have a similar definition for 'tangent from the right'; no need to write it.) What is the relation between tangent from the left, tangent from the right, and tangent?

3.8 Summary of Chapter 3, The Derivative.

You now have an introduction to the concept of rate of change and to the derivative of a function. The derivative and its companion, the integral that is studied in Chapter 9, enabled¹⁰ an explosion in science and mathematics beginning in the late seventeenth century, and remain at the core of science and mathematics today. Briefly, for a suitable function, P , the derivative of P is the function P' defined by

$$P'(t) = \lim_{h \rightarrow 0} \frac{P(t+h) - P(t)}{h} \quad (3.40)$$

¹⁰It might also be argued that the explosion in science enabled or caused the creation of the derivative and integral. The two are inseparable.

We also wrote $P'(t)$ as $[P(t)]'$ and $\frac{dP}{dt}$. A helpful interpretation of $P'(a)$ is that it is the slope of the tangent to the graph of P at the point $(a, P(a))$.

The derivatives of three functions were computed (for C a number and n a positive integer) and we wrote what we call *primary* formulas:

$$\left. \begin{aligned} P(t) = C &\implies P'(t) = 0 && \text{or } [C]' = 0 \\ P(t) = t &\implies P'(t) = 1 && \text{or } [t]' = 1 \\ P(t) = t^n &\implies P'(t) = nt^{n-1} && \text{or } [t^n]' = nt^{n-1} \end{aligned} \right\} \quad (3.41)$$

Two *combination* formulas were developed:

$$\left. \begin{aligned} P(t) = C u(t) &\implies P'(t) = C \times u'(t) \\ P(t) = u(t) + v(t) &\implies P'(t) = u'(t) + v'(t) \end{aligned} \right\} \quad (3.42)$$

They can also be written

$$[Cu(t)]' = C[u(t)]'$$

$$[u(t) + v(t)]' = [u(t)]' + [v(t)]'$$

We will expand both the list of primary formulas and the list of combination formulas in future chapters and thus expand the array of derivatives that you can compute without explicit reference to the Definition of Derivative Equation 3.40.

We saw that derivatives describe rates of chemical reactions, and used the derivative function to find optimum values of spider web design and the height of a pop fly in baseball. We examined two cases of dynamic systems, mold growth and falling objects, using rates of change rather than the average rates of change used in Chapter 1. A vast array of dynamical systems and optimization problems have been solved since the introduction of calculus. We will see some of them in future chapters.

Finally we defined and computed the second derivative and higher order derivatives and gave some geometric interpretations (concave up and concave down) and some physical interpretation (acceleration).

Exercises for Chapter 3, The Derivative.

Chapter Exercise 3.8.1 Use Definition of the Derivative 3.22, $\lim_{b \rightarrow t} \frac{P(b) - P(t)}{b - t}$, to compute the rates of change of the following functions, P .

- | | | |
|--------------------------------|------------------------|----------------------------------|
| a. $P(t) = t^3$ | b. $P(t) = 5t^2$ | c. $P(t) = \frac{t^3}{4}$ |
| d. $P(t) = t^2 + t^3$ | e. $P(t) = 2\sqrt{t}$ | f. $P(t) = \sqrt{2t}$ |
| g. $P(t) = 7$ | h. $P(t) = 5 - 2t$ | i. $P(t) = \frac{1}{1+t}$ |
| j. $P(t) = \frac{1}{3t}$ | k. $P(t) = 5t^7$ | l. $P(t) = \frac{1}{t^2}$ |
| m. $P(t) = \frac{1}{(3t+1)^2}$ | n. $P(t) = \sqrt{t+3}$ | o. $P(t) = \frac{1}{\sqrt{t+1}}$ |

Chapter Exercise 3.8.2 Data from David Dice of Carlton Comprehensive High School in Canada¹¹ for the decrease in mass of a solution of 1 M HCl containing chips of CaCO₃ is shown in Table 3.8.0. The reaction is



The reduction in mass reflects the release of CO₂.

- Graph the data.
- Estimate the rate of change of the mass at each of the times shown.
- Draw a graph of the rate of change of mass versus the mass.

Table for Exercise 3.8.0 Data for Ex. 3.8.2.

Time (min)	Mass (g)	
0.25	248.46	
0.50	247.95	
1.00	246.83	
1.50	245.95	
2.00	245.22	
2.50	244.67	
3.00	244.27	
3.50	243.95	
4.00	243.72	
4.50	243.52	
5.00	243.37	

Chapter Exercise 3.8.3 Use derivative formulas 3.41 and 3.42 to compute the derivative of P . Use Primary formulas only in the last step. Assume the t^n rule $[t^n]' = nt^{n-1}$. to be valid for all numbers n , integer, rational, irrational, positive, and negative. In some cases, algebraic simplification will be required before using a derivative formula.

- | | | |
|---------------------------|--|-------------------------------|
| a. $P(t) = 3t^2 - 2t + 7$ | b. $P(t) = t + \frac{2}{t}$ | c. $P(t) = \sqrt{2t}$ |
| d. $P(t) = (t^2 + 1)^3$ | e. $P(t) = 1/\sqrt{2t}$ | f. $P(t) = 2t^{-3} - 3t^{-2}$ |
| g. $P(t) = \frac{5+t}{t}$ | h. $P(t) = 1 + \sqrt{t}$ | i. $P(t) = (1 + 2t)^2$ |
| j. $P(t) = (1 + 3t)^3$ | k. $P(t) = \frac{1 + \sqrt[3]{t}}{\sqrt{t}}$ | l. $P(t) = \sqrt[3]{2t}$ |

Chapter Exercise 3.8.4 Find an equation of the tangent to the graph of P at the indicated points. Draw the graph P and the tangent.

- | | | | |
|------------------------|-------------|--------------------------|-----------------------|
| a. $P(t) = t^4$ | at $(1, 1)$ | b. $P(t) = t^{12}$ | at $(1, 1)$ |
| c. $P(t) = t^{1/2}$ | at $(4, 2)$ | d. $P(t) = \frac{5}{2}$ | at $(5, 1)$ |
| e. $P(t) = \sqrt{1+t}$ | at $(8, 3)$ | f. $P(t) = \frac{1}{2t}$ | at $(\frac{1}{2}, 1)$ |

¹¹<http://www.carlton.paschools.ps.sk.ca/chemical/chem>

Chapter 4

Continuity and the Power Chain Rule

Where are we going?

We require the concept of *continuity of a function*.

The key to understanding continuity is to understand discontinuity. A continuous function is simply a function that has no discontinuity.

The function F whose graph is shown below is *not* continuous. It has a *discontinuity* at the abscissa, a . There are values of x close to a for which $F(x)$ is not close to $F(a)$. F is continuous at all points except a , but F is still said to be discontinuous. In this game, one strike and you are out.

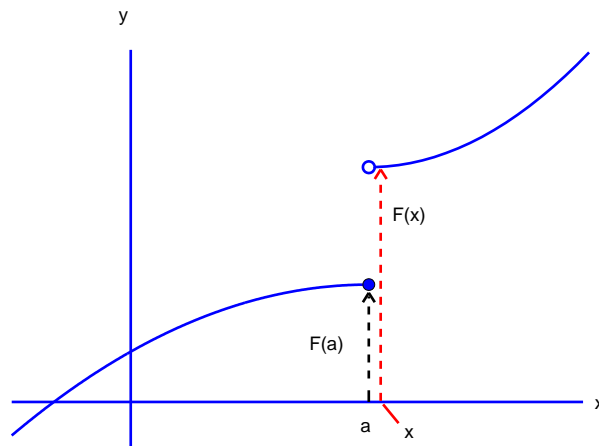

4.1 Continuity.

Most, but not all, of the functions in previous sections and that you will encounter in biology are continuous. Four equivalent definitions of continuity follow, with differing levels of intuition and formality.

Definition 4.1.1 Continuity of a function at a number in its domain.

Intuitive: A function, f , is continuous at a number a in its domain means that if x is in the domain of f and x is close to a , then $f(x)$ is close to $f(a)$.

Symbolic: A function, f , is continuous at a number a in its domain means that either

$$\lim_{x \rightarrow a} f(x) = f(a)$$

or there is an open interval containing a and no other point of the domain of f .

Formal: A function, f , is continuous at a number a in its domain means that for every positive number, ϵ , there is a positive number δ such that if x is in the domain of f and $|x - a| < \delta$ then $|f(x) - f(a)| < \epsilon$.

Geometric A simple graph G is continuous at a point P of G means that if α and β are horizontal lines with P between them there are vertical lines h and k with P between them such that every point of G between h and k is between α and β .

Definition 4.1.2 Discontinuous. If a is a number in the domain of a function f at which f is not continuous then f is said to be discontinuous at a .

Definition 4.1.3 Continuous function. A function, f , is continuous means that f is continuous at every number, a , in its domain.

Explore 4.1.1 . Definition 4.1.2 is a sleeper. What does "not continuous" mean? It is a rite of passage for mathematics students to write the negation of the statement that a function is continuous at a number a in its domain. The statement is sometimes called the "logical complement" or the "bare denial" of the statement of continuity at a . To illustrate, the negation of the *Symbolic Definition* is

Symbolic Definition of Discontinuity: A function, f , which has a number a in its domain is *not continuous at a* means that every open interval containing a contains a point of the domain of f different from a and either

$$\lim_{x \rightarrow a} f(x) \text{ does not exist, or } \lim_{x \rightarrow a} f(x) \text{ exists and is not } = f(a).$$

The *Intuitive Definition* is so imprecise as to make its negation even more difficult. You should try to write that negation, but will likely first write, "There is a number, x , close to a for which $f(x)$ is not close to $f(a)$," but this suffers from the uncertainty of "close to."

Explore 4.1.2 Write the **negation** of the *Formal Definition of Continuity* of a function, f , at a point, a , of its domain. This is something into which you can sink your teeth, deeply.

As a guide, we write a negation of the *Geometric Definition* of continuity.

Geometric Definition of Discontinuity: A simple graph G that contains a point P is not continuous P means that there are horizontal lines α and β with P between them such that for any are vertical lines h and k with P between them some point of G between h and k is not between α and β . ■

Most of the functions that you have experienced are continuous, and to many students it is intuitively obvious from the notation that $u(b)$ approaches $u(a)$ as b approaches a ; but in some cases $u(b)$ does not approach $u(a)$ as b approaches a . Some examples demonstrating both continuity and discontinuity follow.

- Example 4.1.1** 1. You showed in Exercise 3.2.7 that every polynomial is continuous.
2. The function describing serum insulin concentration as a function of time is a continuous function even though it may change quickly with serious consequences.
3. The word 'threshold' suggests a discontinuous change in one parameter as a related parameter crosses the threshold. Stimulus to neurons causes ion gates to open. When an Na^+ ion gate is opened, Na^+ flows into the cell gradually increasing the membrane potential, called a 'graded response' (continuous response), up to a certain threshold at which an action potential is triggered (a rapid increase in membrane potential) that appears to be a discontinuous response. As in almost all biological examples, however, the function is actually continuous. See Example Figure 4.1.1.1A.
4. **Surprise.** The graph in Figure 4.1.1.1B is continuous. There are only three points of the graph. The graph is continuous at, for example, the point (3,2). There is an open interval containing 3, (2.7, 3.3), for example, that contains 3 and no other point of the domain.

Figure for Example 4.1.1.1 A. Events leading to a nerve action potential. B. A discrete graph is continuous.

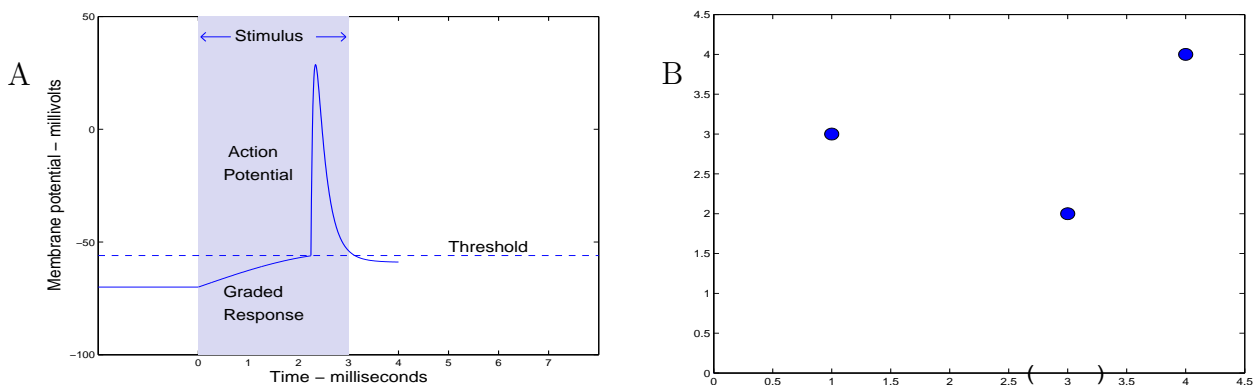

5. The function *approximating* % Female hatched from a clutch of turtle eggs

$$\text{Percent female} = \begin{cases} 0 & \text{if } Temp < 28 \\ 50 & \text{if } Temp = 28 \\ 100 & \text{if } 28 < Temp \end{cases} \quad (4.1)$$

is not continuous. The function is discontinuous at $t = 28$. If the temperature, T , is close to 28 and less than 28, then % Female(T) is 0, which in usual measures is not 'close to' $50 = \% \text{Female}(28)$.

6. As you move up a mountain side, the flora is usually described as being a discontinuous function of altitude. There is a 'tree line', below which the dominant plant species are pine and spruce and above which the dominant plant species are low growing brushes and grasses, as illustrated in Figure 4.1.1.1C¹

Figure for Example 4.1.1.1 (Continued.) C. A tree line. Picture taken from the summit of Independence Pass, Colorado at 12,095 feet (3687 m) elevation.

¹Such a region of apparent discontinuity is termed an 'ecotone' by ecologists.



7. We acknowledge that the tree line in Figure 4.1.1.1 is not sharp and some may not agree that it marks a discontinuity.

It is important to the concept of discontinuity that there be an abrupt change in the dependent variable with only a gradual change in the independent variable. Charles Darwin expressed it:

Charles Darwin, *Origin of Species*. Chap. VI, Difficulties of the Theory. “We see the same fact in ascending mountains, and sometimes it is quite remarkable how abruptly, as Alph. de Candolle has observed, a common alpine species disappears. The same fact has been noticed by E. Forbes in sounding the depths of the sea with the dredge. To those who look at climate and the physical conditions of life as the all-important elements of distribution, these facts ought *to cause surprise, as climate and height or depth graduate away insensibly* [our emphasis].”

8. From Equation 3.12, $\lim_{x \rightarrow a} \frac{1}{x} = \frac{1}{a}$, the function, $f(x) = \frac{1}{x}$ is continuous. The graph of $f(x)$ certainly changes rapidly near $x = 0$, and one may think that f is not continuous at $x = 0$. However, 0 is not in the domain of f , so that the function is neither continuous nor discontinuous at $x = 0$.
9. Let the function g be defined by

$$g(x) = \frac{1}{x} \quad \text{for } x \neq 0, \quad g(0) = 2$$

A graph of g is shown in Example Figure 4.1.1.1E. The function g is not continuous at 0 and the graph of g is not continuous at $(0, 2)$. Two horizontal lines above and below $(0, 2)$ are drawn in Figure 4.1.1.1F. For every pair of vertical lines h and k with $(0, 2)$ between them there are points of the graph of g between h and k that are not between α and β .

Figure for Example 4.1.1.1 (Continued) E. The graph of $g(x) = 1/x$ for $x \neq 0$, $g(0) = 2$.
F. The point $(0, 2)$ and horizontal lines above and below $(0, 2)$.

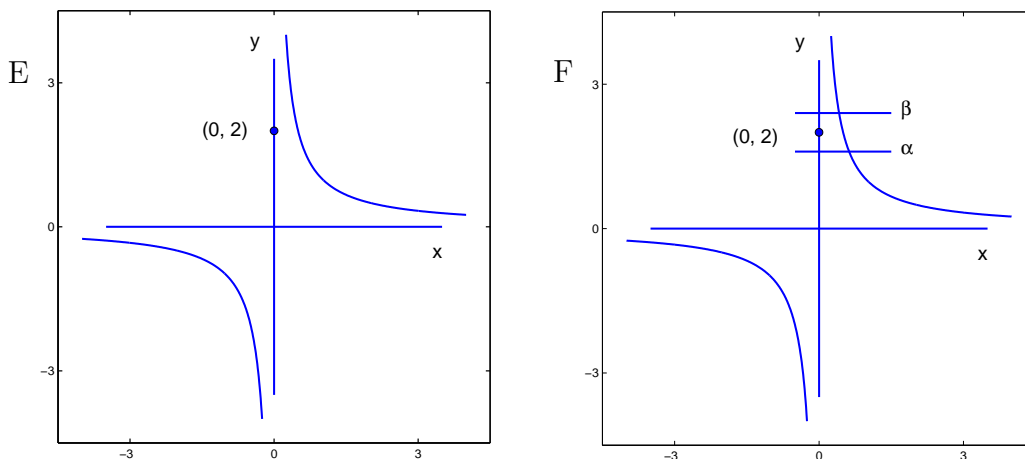

Explore 4.1.3 In Figure 4.1.1 there are two vertical dashed lines with $(0,2)$ between them. It appears that every point of the graph of g between the vertical dashed lines is between the two horizontal lines. Does this contradict the claim made in Item 9? ■

Explore Figure 4.1.1 The graph of $g(x) = 1/x$ for $x \neq 0$, $g(0) = 2$, horizontal lines above and below $(0, 2)$, and vertical lines (dashed) with $(0,2)$ between them.

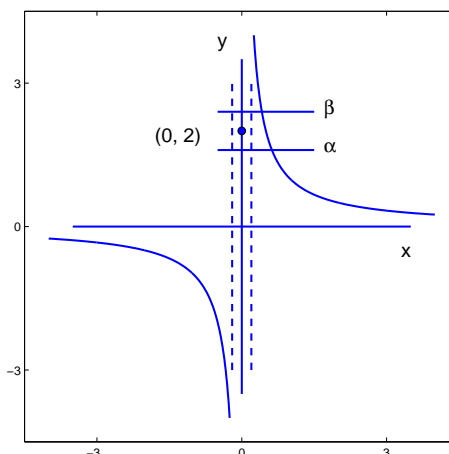

- The geological age of soil is not a continuous function of depth below the surface. Older soils are at a greater depth, so that the age of soils is (almost always) an increasing function of depth. However, in many locations, soils of some ages are missing: soils of age 400 million years may rest directly on top of soils of age 1.7 billion years as shown in Figure 4.1.1.1. Either soils of the intervening ages were not deposited in that location or they were deposited and subsequently eroded. Geologists speak of an “unconformity” occurring at that location and depth.

Figure for Example 4.1.1.1 (Continued) G. Picture of an unconformity at Red Rocks Park and Amphitheatre near Denver, Colorado. Red 300 million year-old sedimentary rocks rest on gray 1.7 billion year-old metamorphic rocks. (Better picture in “Messages in Stone: Colorado’s Colorful Geology” Vincent Matthews, Katie KellerLynn, and Betty Fox, Colorado Geological Survey, Denver, Colorado, 2003) H. Snow line figure taken in New Zealand for Exercise 4.1.4.

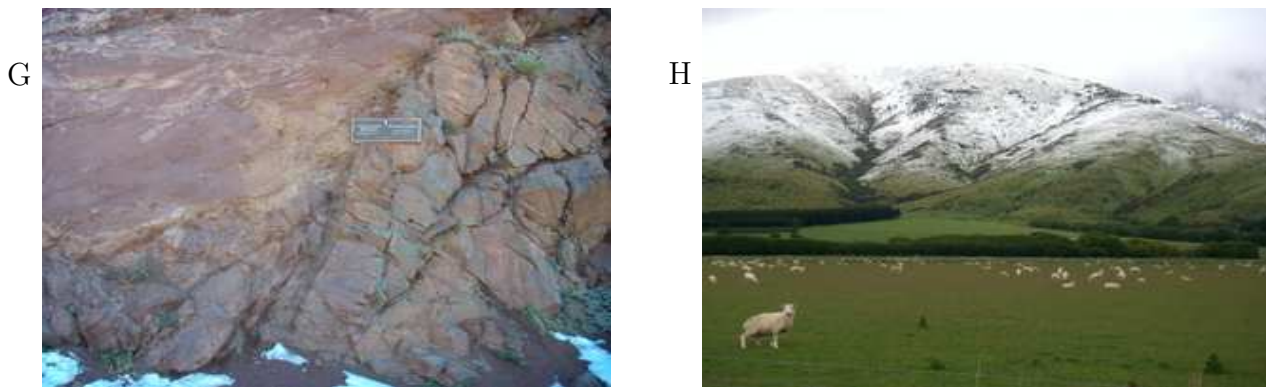

11. Every increasing function defined on an interval that is discontinuous at some point has a vertical gap in the graph at that point. Every increasing function with no gap is continuous. Vertical gap: there is a horizontal line that does not intersect the graph, but has a point of the graph below the line and a point of the graph above the line.

Figure for Example 4.1.1.1 (Continued) H. An increasing function. There are two vertical gaps and two points of discontinuity.

Explore 4.1.4 *Vertical gap* in the graph G means an interval of the Y-axis that contains no point of the Y-projection of G and for which there is a point of the Y-projection of G below the interval and a point of the Y-projection of G above the interval. Is there a continuous and increasing function that has a vertical gap? ■

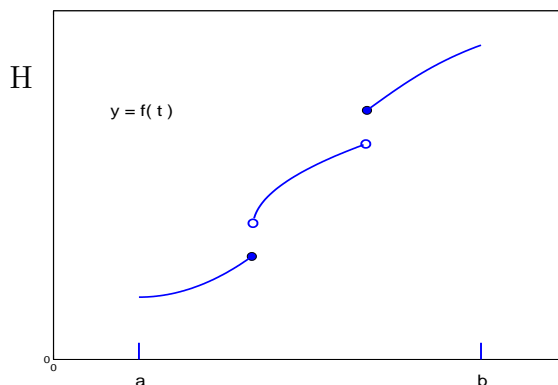

Combinations of continuous functions. We showed in Chapter 3 that

$$\lim_{x \rightarrow a} (F_1(x) + F_2(x)) = \lim_{x \rightarrow a} F_1(x) + \lim_{x \rightarrow a} F_2(x) \quad \text{Equation 3.14}$$

$$\lim_{x \rightarrow a} (F_1(x) \times F_2(x)) = \left(\lim_{x \rightarrow a} F_1(x) \right) \times \left(\lim_{x \rightarrow a} F_2(x) \right) \quad \text{Equation 3.15}$$

If $\lim_{x \rightarrow a} F_2(x) \neq 0$, then $\lim_{x \rightarrow a} \frac{F_1(x)}{F_2(x)} = \frac{\lim_{x \rightarrow a} F_1(x)}{\lim_{x \rightarrow a} F_2(x)}$. Equation 3.18

From these results it follows that if u and v are continuous functions with common domain, D , then

$$u + v \quad \text{and} \quad u \times v \quad \text{are continuous,} \quad (4.2)$$

and if $v(t)$ is not zero for any t in D , then

$$\frac{u}{v} \quad \text{is continuous.} \quad (4.3)$$

Of particular interest is the equation on the limit of composition of two functions,

$$\text{If } \lim_{x \rightarrow a} u(x) = L \quad \text{and} \quad \lim_{s \rightarrow L} F(s) = \lambda, \quad \text{then} \quad \lim_{x \rightarrow a} F(u(x)) = \lambda, \quad \text{Equation 3.17}$$

From this it follows that if F and u are continuous and the domain of F contains the range of u then

$$F \circ u, \quad \text{the composition of } F \text{ with } u, \text{ is continuous.} \quad (4.4)$$

Exercises for Section 4.1, Continuity.

Exercise 4.1.1 1. Find an example of a plant ecotone distinct from the tree line example shown in Figure 4.1.1.1.

2. Find an example of a discontinuity of animal type.

Exercise 4.1.2 For $f(x) = 1/x$,

a. How close must x be to 0.5 in order that $f(x)$ is within 0.01 of 2?

b. How close must x be to 3 in order to insure that $\frac{1}{x}$ be within 0.01 of $\frac{1}{3}$?

c. How close must x be to 0.01 in order to insure that $\frac{1}{x}$ be within 0.1 of 100?

Exercise 4.1.3 Find the value for $u(2)$ that will make u continuous if

$$\text{a. } u(t) = 2t + 5 \quad \text{for } t \neq 2 \quad \text{b. } u(t) = \frac{t^2 - 4}{t - 2} \quad \text{for } t \neq 2$$

$$\text{c. } u(t) = \frac{(t - 2)^2}{|t - 2|} \quad \text{for } t \neq 2 \quad \text{d. } u(t) = \frac{t + 1}{t - 3} \quad \text{for } t \neq 2$$

$$\text{e. } u(t) = \frac{t - 2}{t^3 - 8} \quad \text{for } t \neq 2 \quad \text{f. } u(t) = \frac{\frac{1}{t} - \frac{1}{2}}{t - 2} \quad \text{for } t \neq 2$$

Exercise 4.1.4 In Example Figure 4.1.1.1 H is a picture of snow that fell on the side of a mountain the night before the picture was taken. There is a 'snow line', a horizontal separation of the snow from terrain free of snow below the line. 'Snow' is a discontinuous function of altitude. Explain the source of the discontinuity.

Exercise 4.1.5 a. Draw the graph of y_1 . b. Find a number A such that the graph of y_2 is continuous.

$$\text{a. } y_1(x) = \begin{cases} x^2 & \text{for } x < 2 \\ 3 - x & \text{for } 2 \leq x \end{cases} \quad \text{b. } y_2(x) = \begin{cases} x^2 & \text{for } x < 2 \\ A - x & \text{for } 2 \leq x \end{cases}$$

Exercise 4.1.6 Is the temperature of the water in a lake a continuous function of depth? Write a paragraph discussing water temperature as a function of depth in a lake and how knowledge of water temperature assists in the location of fish.

Exercise 4.1.7 To reduce inflammation in a shoulder, a doctor prescribes that twice daily one Voltaren tablet (25 mg) to be taken with food. Draw a graph representative of the amount of Voltaren in the body as a function of time for a one week period. Is your graph continuous?

Exercise 4.1.8 The function, $f(x) = \sqrt[3]{x}$ is continuous.

1. How close must x be to 1 in order to insure that $f(x)$ is within 0.1 of $f(1) = 1$ (that is, to insure that $0.9 < f(x) < 1.1$)?
2. How close must x be to $1/8$ in order to insure that $f(x)$ is within 0.0001 of $f(1/8) = 1/2$ (that is, to insure that $0.4999 < f(x) < 0.5001$)?
3. How close must x be to 0 in order to insure that $f(x)$ is within 0.1 of $f(0) = 0$?

Exercise 4.1.9 a. Draw the graph of a function, f , defined on the interval $[1, 3]$ such that $f(1) = -2$ and $f(3) = 4$.

b. Does your graph intersect the X-axis?

c. Draw a graph of of a function, f , defined on the interval $[1, 3]$ such that $f(1) = -2$ and $f(3) = 4$ that does not intersect the X-axis. Be sure that its X-projection is all of $[1, 3]$.

d. Write equations to define a function, f , on the interval $[1, 3]$ such that $f(1) = -2$ and $f(3) = 4$ and the graph of f does not intersect the X-axis.

e. There is a theorem that asserts that the function you just defined must be discontinuous at some number in $[1, 3]$. Identify such a number for your example.

The preceding exercise illustrates a general property of continuous functions called the *intermediate value property*. Briefly it says that a continuous function defined on an interval that has both positive and negative values on the interval, must also be zero somewhere on the interval. In language of graphs, the graph of a continuous function defined on an interval that has a point below the X-axis and a point above the X-axis must intersect the X-axis. The proof of this property requires more than the familiar properties of addition, multiplication, and order of the real numbers. It requires the *completion* property of the real numbers, Axiom 5.2.1².

Exercise 4.1.10 A nutritionist studying plasma epinephrine (EPI) kinetics with tritium labeled epinephrine, $[^3\text{H}]\text{EPI}$, observes that after a bolus injection of $[^3\text{H}]\text{EPI}$ into plasma, the time-dependence of $[^3\text{H}]\text{EPI}$ level is well approximated by $L(t) = 4e^{-2t} + 3e^{-t}$ where $L(t)$ is the level of $[^3\text{H}]\text{EPI}$ t hours after infusion. Sketch the graph of L . Observe that $L(0) = 7$ and $L(2) = 0.479268$. The intermediate value property asserts that at some time between 0 and 2 hours the level of $[^3\text{H}]\text{EPI}$ will be 1.0. At what time, t_1 , will $L(t_1) = 1.0$? (Let $A = e^{-t}$ and observe that $A^2 = e^{-2t}$.)

²The intermediate value property is equivalent to the completion property within the usual axioms of the number system. See Exercise 12.1.8

Exercise 4.1.11 For the function, $f(x) = 10 - x^2$, find an open interval, $(3 - \delta, 3 + \delta)$ so that $f(x) > 0$ for x in $(3 - \delta, 3 + \delta)$.

Exercise 4.1.12 For the function, $f(x) = \sin(x)$, find an open interval, $(3 - \delta, 3 + \delta)$ so that $f(x) > 0$ for x in $(3 - \delta, 3 + \delta)$.

Exercise 4.1.13 The previous two problems illustrate a property of continuous functions formulated in the Locally Positive Theorem:

Theorem 4.1.1 Locally Positive Theorem. *If a function, f , is continuous at a number a in its domain and $f(a)$ is positive, then there is a positive number, δ , such that $f(x)$ is positive for every number x in $(a - \delta, a + \delta)$ and in the domain of f .*

Prove the Locally Positive Theorem. Your proof may begin:

1. Suppose the hypothesis of the Locally Positive Theorem.
2. Let $\epsilon = f(a)$.
3. Use the hypothesis that $\lim_{x \rightarrow a} f(x) = f(a)$.

Exercise 4.1.14 Is it true that if a function, f , is positive at a number a in its domain, then there is a positive number, δ , such that if x is in $(a - \delta, a + \delta)$ and in the domain of f then $f(x) > 0$?

4.2 The Derivative Requires Continuity.

Suppose u is a function.

$$\text{If } \lim_{b \rightarrow 3} \frac{u(b) - 5}{b - 3} = 4, \quad \text{what is } \lim_{b \rightarrow 3} u(b) ?$$

The answer is that

$$\lim_{b \rightarrow 3} u(b) = 5$$

We reason that

for b close to 3, the numerator of $\frac{u(b) - 5}{b - 3}$ is close to 4 times the denominator.

That is, $u(b) - 5$ is close to $4 \times (b - 3)$.

But $4 \times (b - 3)$ is also close to zero. Therefore

If b is close to 3, $u(b) - 5$ is close to zero and $u(b)$ is close to 5.

The general question we address is:

Theorem 4.2.1 The Derivative Requires Continuity. If u is a function and $u'(t)$ exists at $t = a$ then u is continuous at $t = a$.

Proof. In Exercise 4.2.2 you are asked to give reasons for the following steps, (i) – (v). Suppose the hypothesis of Theorem 4.2.1.

$$\begin{aligned}
 \left(\lim_{b \rightarrow a} u(b) \right) - u(a) &= \lim_{b \rightarrow a} (u(b) - u(a)) && (i) \\
 &= \lim_{b \rightarrow a} \frac{u(b) - u(a)}{b - a} \times (b - a) \\
 &= \lim_{b \rightarrow a} \frac{u(b) - u(a)}{b - a} \times \lim_{b \rightarrow a} (b - a) && (ii) \\
 &= u'(a) \lim_{b \rightarrow a} (b - a) && (iii) \\
 &= 0 && (iv) \\
 \left(\lim_{b \rightarrow a} u(b) \right) &= u(a) && (v)
 \end{aligned}
 \tag{4.5}$$

End of proof.

A graph of a function u defined by

$$u(t) = \begin{cases} 0 & \text{for } 20 \leq t < 28 \\ 50 & \text{for } t = 28 \\ 100 & \text{for } 28 < t \leq 30 \end{cases}
 \tag{4.6}$$

is shown in Figure 4.1A. We observed in Section 4.1 that u is not continuous at $t = 28$.

($\lim_{t \rightarrow 28^-} u(t) = 0 \neq 50 = u(28)$.) Furthermore, $u'(28)$ does not exist. A secant to the graph through $(b, 0)$ and $(28, 50)$ with $b < 28$ is drawn in Figure 4.1B, and

$$\text{for } b < 28, \quad \frac{u(b) - u(28)}{b - 28} = \frac{0 - 50}{b - 28} = \frac{50}{28 - b}$$

The slope of the secant gets greater and greater as b gets close to 28.

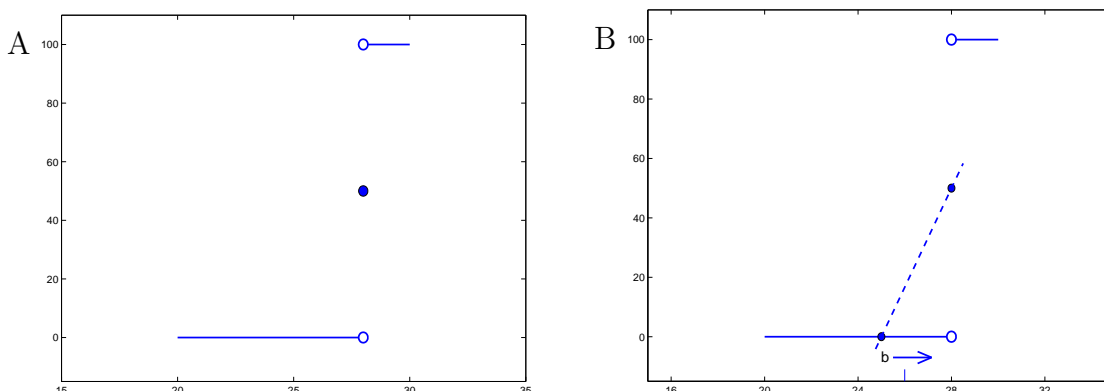

Figure 4.1: A. Graph of The function u defined in Equation 4.6. B. Graph of u and a secant to the graph through $(b, 0)$ and $(28, 50)$.

Explore 4.2.1 Is there a line tangent to the graph of u shown in Figure 4.1 at the point $(28, 50)$ of the graph? ■

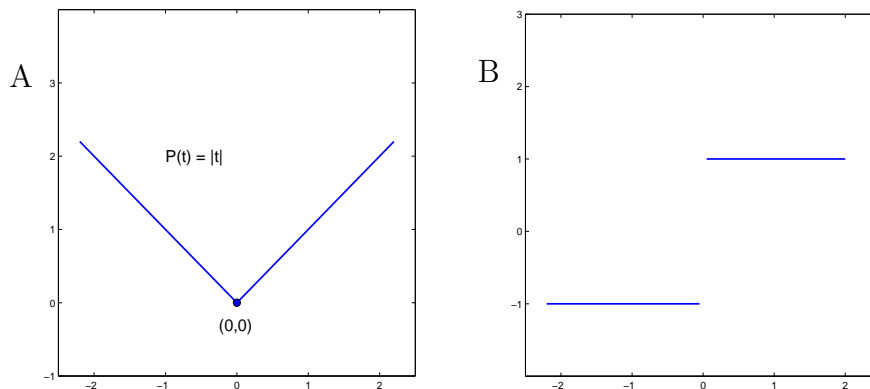
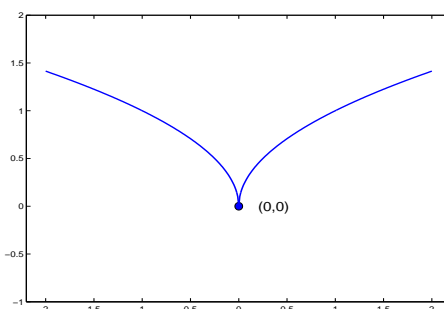

Figure 4.2: a. Graph of $P(t) = |t|$ for all t . B. Graph of $(P(t) - P(0))/(t - 0)$.

Explore 4.2.2 In Explore Figure 4.2.2 is the graph of $y = \sqrt{|x|}$. Does the graph have a tangent at $(0,0)$? **Your vote counts.** ■

Explore Figure 4.2.2 Graph of $y = \sqrt{|x|}$.



The graph of $P(t) = |t|$ for all t is shown in Figure 4.2A. P is continuous, but $P'(0)$ does not exist.

$$\frac{P(b) - P(0)}{b - 0} = \frac{|b| - 0}{b - 0} = \frac{|b|}{b} = \begin{cases} -1 & \text{for } b < 0 \\ 1 & \text{for } b > 0 \end{cases}$$

A graph of $\frac{P(b) - P(0)}{b - 0}$ is shown in Figure 4.2B. It should be clear that

$$\lim_{b \rightarrow 0} \frac{P(b) - P(0)}{b - 0} \quad \text{does not exist, so that} \quad P'(0) \quad \text{does not exist.}$$

Therefore, the converse of Theorem 4.2.1 is not true. Continuity does not imply that the derivative exists.

Exercises for Section 4.2, The Derivative Requires Continuity.

Exercise 4.2.1 Shown in Figure 4.2.1 is the graph of $C(t) = \sqrt[3]{t}$.

- Use Definition of Derivative Equation 3.22 to show that $C'(0)$ does not exist.
- Is $C(t)$ continuous?

c. Is there a line tangent to the graph of C at $(0,0)$?

Figure for Exercise 4.2.1 Graph of $C(t) = \sqrt[3]{t}$ for Exercise 4.2.1.

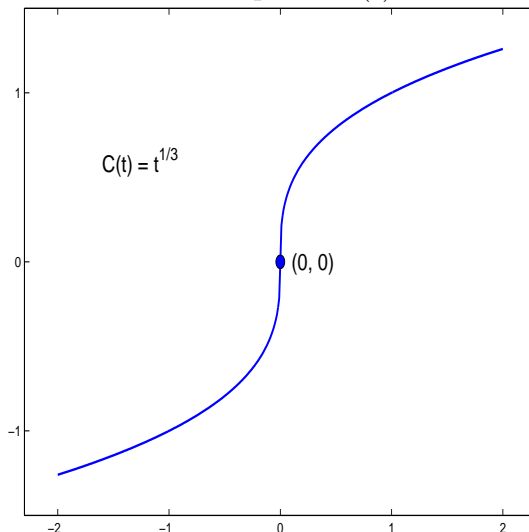

Exercise 4.2.2 Justify the steps (i) – (v) in Equations 4.5.

Exercise 4.2.3 For the function $P(t) = |t|$ for all t compute $P'^-(0)$ and $P'^+(0)$.

Explore 4.2.3 **This problem may require extensive thought.** Is there a function defined for all numbers t and continuous at every number t and for which $f'^-(1)$ does not exist? ■

4.3 The generalized power rule.

In Section 3.5 we proved the Power Rule: for all positive integers, n ,

$$[t^n]' = n t^{n-1}$$

We show here the **generalized power rule**.

Suppose n is a positive integer and $u(t)$ is a function that has a derivative for all t . We use the notation

$$(u(t))^n = u^n(t). \quad \text{Then} \quad [u^n(t)]' = n u^{n-1}(t) \times u'(t). \quad (4.7)$$

The generalized power rule is used in the following setting. Suppose

$$P(t) = (1 + t^2)^3$$

There are two options for computing $P'(t)$.

Option A. Expand the binomial:

$$\begin{aligned} P(t) &= (1 + t^2)^3 \\ &= 1 + 3t^2 + 3t^4 + t^6 \end{aligned}$$

Then use the Sum, Constant, Constant Factor, and Power Rules to show that

$$P'(t) = 0 + 6t + 12t^3 + 6t^5$$

Option B. Use the Generalized Power Rule with $u(t) = 1 + t^2$. Then

$$\begin{aligned} P(t) &= (1 + t^2)^3 &&= u^3(t) \\ P'(t) &= 3(1 + t^2)^2 \times [1 + t^2]' &&= 3u^2(t) \times u'(t) \\ &= 3(1 + t^2)^2 \times 2t \end{aligned}$$

The answers are the same, for

$$3(1 + t^2)^2 \times 2t = 3(1 + 2t^2 + t^4) \times 2t = 6t + 12t^3 + 6t^5$$

Option A (expand the binomial) may appear easier than Option B (use the generalized power rule), but the generalized power rule is clearly easier for a problem like

$$\text{Compute } P'(t) \text{ for } P(t) = (1 + t^2)^{10}$$

Expanding $(1 + t^2)^{10}$ into polynomial form is tedious (if you try it you may conclude that it is a worse than tedious). On the other hand, using the generalize power rule

$$P'(t) = 10(1 + t^2)^9 \times [1 + t^2]' = 10(1 + t^2)^9 \times 2t$$

A special strength of the generalized power rule is that when u is positive, Equation 4.7 is valid for all numbers n (integer, rational, irrational, positive, negative). Thus for $P(t) = \sqrt{1 + t^2}$,

$$\begin{aligned} P'(t) &= [\sqrt{1 + t^2}]' \\ &= \left[(1 + t^2)^{\frac{1}{2}} \right]' && \text{Change to fractional exponent.} \\ &= \frac{1}{2} (1 + t^2)^{\frac{1}{2}-1} \times [1 + t^2]' && \text{Generalized Power Rule.} \\ &= \frac{1}{2} (1 + t^2)^{-\frac{1}{2}} \times 2t && \text{Sum, Constant, Power Rules} \end{aligned}$$

You will prove that when u is positive Equation 4.7, $[u^n(t)]' = n u^{n-1} \times u'(t)$, is valid for n a negative integer (Exercise 4.3.3) and for n a rational number (Exercise 4.3.4).

Proof of the Generalized Power Rule. Assume that n is a positive integer, $u(t)$ is a function and $u'(t)$ exists. Then

$$\text{Equations to prove the GPR. See Exercise 4.3.2.} \tag{4.8}$$

$$[u^n(t)]' = \lim_{b \rightarrow t} \frac{u^n(b) - u^n(t)}{b - t} = \quad (i)$$

$$= \lim_{b \rightarrow t} \frac{(u^{n-1}(b) + u^{n-2}(b)u(t) + \cdots + u(b)u^{n-2}(t) + u^{n-1}(t)) \times (u(b) - u(t))}{b - t} \quad (ii)$$

$$= \lim_{b \rightarrow t} \left((u^{n-1}(b) + u^{n-2}(b)u(t) + \cdots + u(b)u^{n-2}(t) + u^{n-1}(t)) \times \frac{(u(b) - u(t))}{b - t} \right) \quad (iii)$$

$$= \lim_{b \rightarrow t} (u^{n-1}(b) + u^{n-2}(b)u(t) + \cdots + u(b)u^{n-2}(t) + u^{n-1}(t)) \times \lim_{b \rightarrow t} \frac{(u(b) - u(t))}{b - t} \quad (iv)$$

$$= \lim_{b \rightarrow t} (u^{n-1}(b) + u^{n-2}(b)u(t) + \cdots + u(b)u^{n-2}(t) + u^{n-1}(t)) \times u'(t) \quad (v)$$

$$= \left(\lim_{b \rightarrow t} u^{n-1}(b) + \lim_{b \rightarrow t} u^{n-2}(b)u(t) + \cdots + \lim_{b \rightarrow t} u(b)u^{n-2}(t) + \lim_{b \rightarrow t} u^{n-1}(t) \right) \times u'(t) \quad (vi)$$

$$= \left(\lim_{b \rightarrow t} u^{n-1}(b) + u(t) \lim_{b \rightarrow t} u^{n-2}(b) + \cdots + u^{n-2}(t) \lim_{b \rightarrow t} u(b) + \lim_{b \rightarrow t} u^{n-1}(t) \right) \times u'(t) \quad (vii)$$

$$= \left(\lim_{b \rightarrow t} u^{n-1}(b) + u(t) \lim_{b \rightarrow t} u^{n-2}(b) + \cdots + u^{n-2}(t) \lim_{b \rightarrow t} u(b) + u^{n-1}(t) \right) \times u'(t) \quad (viii)$$

$$= \left(\lim_{b \rightarrow t} u^{n-1}(b) + u(t) \lim_{b \rightarrow t} u^{n-2}(b) + \cdots + u^{n-2}(t) \lim_{b \rightarrow t} u(b) + u^{n-1}(t) \right) \times u'(t) \quad (ix)$$

$$= \left(\underbrace{u^{n-1}(t) + u^{n-1}(t) + \cdots + u^{n-1}(t) + u^{n-1}(t)}_{n \text{ terms}} \right) \times u'(t) \quad (x)$$

$$= n u^{n-1}(t) \times u'(t) \quad \text{Whew!}$$

End of Proof.

Explore 4.3.1 In Explore Figure 4.3.1 is a graph of F defined by

$$F(x) = x \quad \text{for } x = 0 \text{ or } x \text{ is the reciprocal of a positive integer.}$$

Only 13 of the infinitely many points of the graph of F are plotted. What is the graph of F' ? **Your vote counts.** ■

Explore Figure 4.3.1 Thirteen of the infinitely many points of the graph of $y = x$ for $x = 0$ or x is the reciprocal of a positive integer.

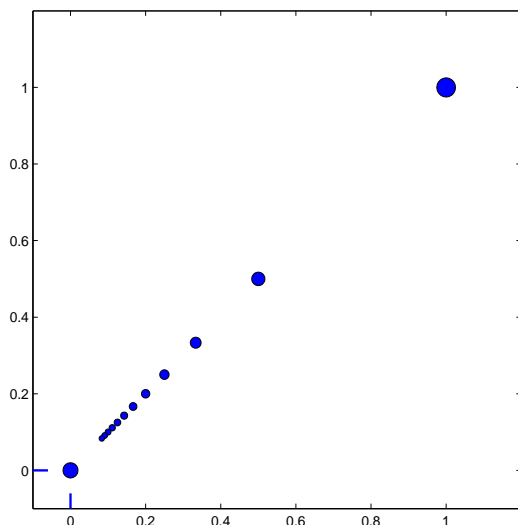

To demonstrate use of the generalized power rule, we announce a *Primary Formula* that is proved in Chapter 7.

$$[\sin t]' = \cos t, \tag{4.9}$$

The derivative of the sine function is the cosine function.

Then, for $(\sin t)^2 = \sin^2 t$,

$$\begin{aligned} [\sin^2 t]' &= 2 \sin^{2-1} t \times [\sin t]' && \text{Generalized Power Rule} \\ &= 2 \sin t \times \cos t && \text{Equation 4.9} \end{aligned} \tag{4.10}$$

Now consider that $\cos t = \sqrt{1 - \sin^2 t}$ for $0 \leq t \leq \pi/2$.

$$\begin{aligned} [\cos t]' &= \left[(1 - \sin^2 t)^{\frac{1}{2}} \right]' && \text{Definition of } P \\ &= \frac{1}{2} (1 - \sin^2 t)^{\frac{1}{2}-1} \times [1 - \sin^2 t]' && \text{Generalized Power Rule} \\ &= \frac{1}{2} (1 - \sin^2 t)^{\frac{1}{2}-1} \times \left([1]' - [\sin^2 t]' \right) && \text{Sum Rule for Derivatives} \\ &= \frac{1}{2} \frac{1}{\sqrt{1 - \sin^2 t}} \times \left(0 - 2 \sin t \cos t \right) && [C]' = 0 \text{ and Eq 4.10} \\ &= -\sin t && \text{Trigonometric simplification.} \end{aligned}$$

One might then guess (correctly) that

$$[\cos t]' = -\sin t \quad \text{for all } t.$$

Observe the exaggerated $\left(\right)$'s in the step marked 'Sum Rule for Derivatives.' Students tend to omit writing those parentheses. They may carry them mentally or may lose them. The $\left(\right)$'s are

necessary. Without them, the steps would lead to

$$\begin{aligned}
 P' &= \frac{1}{2} (1 - \sin^2 t)^{\frac{1}{2}-1} \times [1 - \sin^2 t]' && \text{Generalized Power Rule} \\
 &= \frac{1}{2} (1 - \sin^2 t)^{\frac{1}{2}-1} \times [1]' - [\sin^2 t]' && \text{Sum Rule for Derivatives} \\
 &= \frac{1}{2} (1 - \sin^2 t)^{\frac{1}{2}-1} \times 0 - 2 \sin t \cos t && [C]' = 0 \text{ and Eq 4.10} \\
 &= -2 \sin t \cos t && \text{Trigonometric simplification.}
 \end{aligned}$$

Unfortunately, the answer is incorrect. Always:

First Notice.
Use parentheses, ()'s, they are cheap.

4.3.1 The Power Chain Rule.

The Generalized Power Rule is one of a collection of rules called **chain rules** and henceforth we will refer to it as the Power Chain Rule. The reason for the word, ‘chain’ is that the rule is often a ‘link’ in a ‘chain’ of steps leading to a derivative. Because of its form

$$[u(t)^n]' = nu(t)^{n-1} \times [u(t)]',$$

when the Power Chain Rule is used, there always remains a derivative, $[u(t)]'$, to compute after the Power Chain Rule is used. **The power chain rule is never the final step – the final step is always one or more of the *Primary Formulas*.**

For example, compute the derivative of

$$y = \frac{1}{1 + \sqrt{x+1}} = (1 + (x+1)^{1/2})^{-1}$$

$$\begin{aligned}
 y' &= \left[(1 + (x+1)^{1/2})^{-1} \right]' && \text{Logical Identity} \\
 &= (-1) (1 + (x+1)^{1/2})^{-2} \times [1 + (x+1)^{1/2}]' && \text{Power Chain Rule} \\
 &= (-1) (1 + (x+1)^{1/2})^{-2} (0 + [(x+1)^{1/2}]') && \text{Sum and Constant Rules} \\
 &= (-1) (1 + (x+1)^{1/2})^{-2} (1/2)(x+1)^{-1/2} [x+1]' && \text{Power Chain Rule} \\
 &= (-1) (1 + (x+1)^{1/2})^{-2} (1/2)(x+1)^{-1/2} (1+0) && \text{Power and Constant Rules}
 \end{aligned}$$

Exercises for Section 4.3, The generalized power rule.**Exercise 4.3.1** Compute $P'(t)$ for

a. $P(t) = (2 + t^2)^4$ b. $P(t) = (1 + \sin t)^3$

c. $P(t) = (t^4 + 5)^2$ d. $P(t) = (6t^7 + 5^4)^9$

e. $P(t) = \left(\frac{t}{8} + t^2\right)^2$ f. $P(t) = (t^2 + \sin t)^{13}$

g. $P(t) = \left(\frac{1}{t} + t\right)^2$ h. $P(t) = \left(\frac{5}{t} + \frac{t}{3}\right)^2$

i. $P(t) = \frac{1}{t+5}$ j. $P(t) = \frac{2}{(1+t)^2}$

Exercise 4.3.2 Give reasons to support each of the equality signs labeled (i) – quad – (x) in Equations 4.8 to prove the Generalized Power Rule. Each equality can be justified by reference to algebra, to one of the limit formulas Equations 3.10 through 3.15 (shown next), or Theorem 4.2.1, The Derivative Requires Continuity, or the definition of the derivative, Equation 3.22. Equations 3.10 through 3.15 are:

Eq 3.10 $\lim_{x \rightarrow a} C = C$ Eq 3.11 $\lim_{x \rightarrow a} x = a$

Eq 3.12 $\lim_{x \rightarrow a} \frac{1}{x} = \frac{1}{a}$ Eq 3.13 $\lim_{x \rightarrow a} C F(x) = C \lim_{x \rightarrow a} F(x)$

Eq 3.14 $\lim_{x \rightarrow a} (F_1(x) + F_2(x)) = \lim_{x \rightarrow a} F_1(x) + \lim_{x \rightarrow a} F_2(x)$

Eq 3.15 $\lim_{x \rightarrow a} (F_1(x) \times F_2(x)) = \left(\lim_{x \rightarrow a} F_1(x)\right) \times \left(\lim_{x \rightarrow a} F_2(x)\right)$

Eq 3.22 $F'(x) = \lim_{b \rightarrow x} \frac{F(b) - F(x)}{b - x}$

Exercise 4.3.3 Suppose m is a positive integer and a function u has a derivative at t and that $u(t) \neq 0$. Give reasons for the equalities (i) – (vii) below that show

$$\left[u^{-m}(t) \right]' = (-m) u^{-m-1}(t) \times u'(t)$$

$$\begin{aligned}
[u^{-m}(t)]' &\stackrel{(i)}{=} \lim_{b \rightarrow t} \frac{u^{-m}(b) - u^{-m}(t)}{b - t} \\
&= \lim_{b \rightarrow t} \frac{\frac{1}{u^m(b)} - \frac{1}{u^m(t)}}{b - t} \\
&= \lim_{b \rightarrow t} \frac{u^m(t) - u^m(b)}{u^m(b) \times u^m(t)} \times \frac{1}{b - t} \\
&\stackrel{(ii)}{=} - \lim_{b \rightarrow t} \frac{u^{m-1}(t) + u^{m-2}(t)u(b) + \cdots + u(t)u^{m-2}(b) + u^{m-1}(b)}{u^m(b) \times u^m(t)} \times \frac{u(b) - u(t)}{b - t} \\
&\stackrel{(iii)}{=} - \frac{\lim_{b \rightarrow t} \left(u^{m-1}(t) + u^{m-2}(t)u(b) + \cdots + u(t)u^{m-2}(b) + u^{m-1}(b) \right)}{\lim_{b \rightarrow t} u^m(b) \times u^m(t)} \times \lim_{b \rightarrow t} \frac{u(b) - u(t)}{b - t} \\
&\stackrel{(iv)}{=} - \frac{\lim_{b \rightarrow t} \left(u^{m-1}(t) + u^{m-2}(t)u(b) + \cdots + u(t)u^{m-2}(b) + u^{m-1}(b) \right)}{u^m(t) \times u^m(t)} \times \lim_{b \rightarrow t} \frac{u(b) - u(t)}{b - t} \\
&\stackrel{(v)}{=} - \frac{\lim_{b \rightarrow t} \left(u^{m-1}(t) + u^{m-2}(t)u(b) + \cdots + u(t)u^{m-2}(b) + u^{m-1}(b) \right)}{u^m(t) \times u^m(t)} \times u'(t) \\
&\stackrel{(vi)}{=} - \frac{u^{m-1}(t) + u^{m-1}(t) + \cdots + u^{m-1}(t) + u^{m-1}(t)}{u^m(t) \times u^m(t)} \times u'(t) \\
&\stackrel{(vii)}{=} (-m) u^{-m-1}(t) \times u'(t)
\end{aligned}$$

Exercise 4.3.4 Suppose p and q are integers and u is a positive function that has a derivative at all numbers t . Assume that $[u^{\frac{p}{q}}(t)]'$ exists. Give reasons for the steps (i) – (iv) below that show

$$[u^{\frac{p}{q}}(t)]' = \frac{p}{q} u^{\frac{p}{q}-1}(t) \times u'(t).$$

Let

$$v(t) = u^{\frac{p}{q}}(t).$$

Then

$$v^q(t) = u^p(t) \tag{i}$$

$$[v^q(t)]' = [u^p(t)]'$$

$$q v^{q-1}(t) \times v'(t) = p u^{p-1}(t) \times u'(t) \tag{ii}$$

$$v'(t) = \frac{p}{q} \frac{u^{p-1}(t)}{\left(u^{\frac{p}{q}}\right)^{q-1}} \times u'(t) \tag{iii}$$

$$[u^{\frac{p}{q}}(t)]' = \frac{p}{q} u^{\frac{p}{q}-1}(t) \times u'(t) \tag{iv}$$

4.4 Applications of the Power Chain Rule.

The Power Chain Rule

$$\text{PCR:} \quad [u^n(t)]' = n u^{n-1}(t) \times u'(t) = n u^{n-1}(t) u'(t) \quad (4.11)$$

greatly expands the diversity and interest of problems that we can analyze. Note that the second form omits the \times symbol; multiplication is implied by the juxtaposition of symbols. The general chain rule also will be written

$$[G(u(x))] = G'(u(x)) u'(x)$$

Some introductory examples follow.

Example 4.4.1 A. Find the slope of the tangent to the circle, $x^2 + y^2 = 13$, at the point $(2,3)$. See Figure 4.3.

B. Also find the slope of the tangent to the circle, $x^2 + y^2 = 13$, at the point $(3,-2)$.

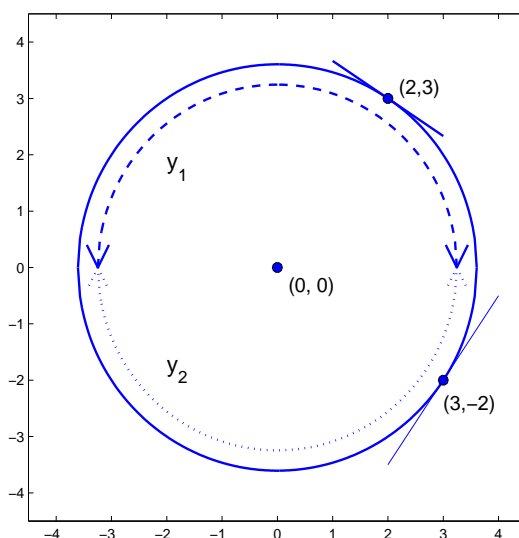

Figure 4.3: Graph of the circle $x^2 + y^2 = 13$ and tangents drawn at the points $(2,3)$ and $(3,-2)$ of the circle.

Solution First check that $2^2 + 3^2 = 4 + 9 = 13$, so that $(2,3)$ is indeed a point of the circle. Then solve for y in $x^2 + y^2 = 13$ to get

$$y_1 = \sqrt{13 - x^2}$$

Then the Power Chain Rule with $n = \frac{1}{2}$ yields

$$\begin{aligned}
 y_1' &= \left[\sqrt{13 - x^2} \right]' = \left[(13 - x^2)^{\frac{1}{2}} \right]' && (i) \text{ Symbolic identity} \\
 &= \frac{1}{2} (13 - x^2)^{\frac{1}{2}-1} \times [13 - x^2]' && (ii) \text{ PCR, } n = 1/2 \text{ } u = 1 - x^2 \\
 &= \frac{1}{2} (13 - x^2)^{-\frac{1}{2}} \times \left([13]' - [x^2]' \right) && (iii) \text{ Sum Rule} \\
 &= \frac{1}{2} (13 - x^2)^{-\frac{1}{2}} \times (0 - 2x) && (iv) \text{ Constant and Power Rules} \\
 &= -x (13 - x^2)^{-\frac{1}{2}}
 \end{aligned}$$

Observe the exaggerated $()$'s in steps (iii) and (iv). Students tend to omit writing them, but they are necessary. Without the $()$'s, steps (iii) and (iv) would lead to

$$\begin{aligned}
 y_1' &= \frac{1}{2} (13 - x^2)^{-\frac{1}{2}} \times [13]' - [x^2]' && (iii) \text{ Sum Rule} \\
 &= \frac{1}{2} (13 - x^2)^{-\frac{1}{2}} \times 0 - 2x && (iv) \text{ Constant and Power Rules} \\
 &= -2x
 \end{aligned}$$

a notably simpler answer, but unfortunately incorrect. Always:

Second Notice.
Use parentheses, $()$'s, they are cheap.

To finish the computation, we compute y_1' at $x = 2$ and get

$$y_1'(2) = (-2) (13 - 2^2)^{-\frac{1}{2}} = -\frac{2}{3}$$

and the slope of the tangent to $x^2 + y^2 = 13$ at $(2,3)$ is $-2/3$. An equation of the tangent is

$$\frac{y - 3}{x - 2} = -\frac{2}{3} \quad \text{or} \quad y = -\frac{2}{3}x + 4\frac{1}{3}$$

B. Now we find the tangent to the circle $x^2 + y^2 = 13$ at the point $(3,-2)$. Observe that $3^2 + (-2)^2 = 4 + 9 = 13$ so that $(2,-3)$ is a point of $x^2 + y^2 = 13$, but $(3,-2)$ **does not** satisfy

$$y_1 = (13 - x^2)^{\frac{1}{2}}$$

because

$$-2 \neq (13 - (-3)^2)^{\frac{1}{2}} = 2$$

For (3,-2) we must use the lower semicircle and

$$y_2 = -\left(13 - x^2\right)^{\frac{1}{2}}$$

Then

$$\begin{aligned} y_2' &= -\left[\left(13 - x^2\right)^{\frac{1}{2}}\right]' \\ &= -\frac{1}{2}\left(13 - x^2\right)^{\frac{1}{2}-1}\left[1 - x^2\right]' \\ &= -\frac{1}{2}\left(13 - x^2\right)^{-\frac{1}{2}}(-2x) \end{aligned}$$

At $x = 3$

$$y_2'(3) = -\frac{1}{2}\left(13 - 3^2\right)^{-\frac{1}{2}}(-2 \times 3) = \frac{3}{2}$$

and the slope of the line drawn is $3/2$. ■

It is often helpful to put the denominator of a fraction into the numerator with a negative exponent. For example:

Problem. Compute $P'(t)$ for $P(t) = \frac{5}{(1+t)^2}$. *Solution*

$$\begin{aligned} P'(t) &= \left[\frac{5}{(1+t)^2}\right]' \\ &= \left[5(1+t)^{-2}\right]' \\ &= 5\left[(1+t)^{-2}\right]' \\ &= 5\left((-2)(1+t)^{-3}\right) \times [(1+t)]' \\ &= 5(-2)(1+t)^{-3} \times 1 = -10(1+t)^{-3} \end{aligned}$$

aaa We will find additional important uses of the power rules in the next section.

Exercises for Section 4.4, Applications of the Power Chain Rule.

Exercise 4.4.1 Compute $y'(x)$ for

- | | | | | | |
|----|------------------------|----|---------------------|----|-------------------------------|
| a. | $y = 2x^3 - 5$ | b. | $y = \frac{2}{x^2}$ | c. | $y = \frac{5}{(x+1)^2}$ |
| d. | $y = (1+x^2)^{0.5}$ | e. | $y = \sqrt{1-x^2}$ | f. | $y = (1-x^2)^{-0.5}$ |
| g. | $y = (2-x)^4$ | h. | $y = (3-x^2)^4$ | i. | $y = \frac{1}{\sqrt{7-x^2}}$ |
| j. | $y = (1+(x-2)^2)^2$ | k. | $y = (1+3x)^{1.5}$ | l. | $y = \frac{1}{\sqrt{16-x^2}}$ |
| m. | $y = \sqrt{9-(x-4)^2}$ | n. | $y = (9-x^2)^{1.5}$ | o. | $y = \sqrt[3]{1-3x}$ |

Exercise 4.4.2 Shown in Figure Ex. 4.4.2 is the ellipse,

$$\frac{x^2}{18} + \frac{y^2}{8} = 1$$

and a tangent to the ellipse at (3,2).

- Find the slope of the tangent.
- Find an equation of the tangent.
- Find the x - and y -intercepts of the tangent.

Figure for Exercise 4.4.2 Graph of the ellipse $x^2/18 + y^2/8 = 1$ and a tangent to the ellipse at the point (3,2).

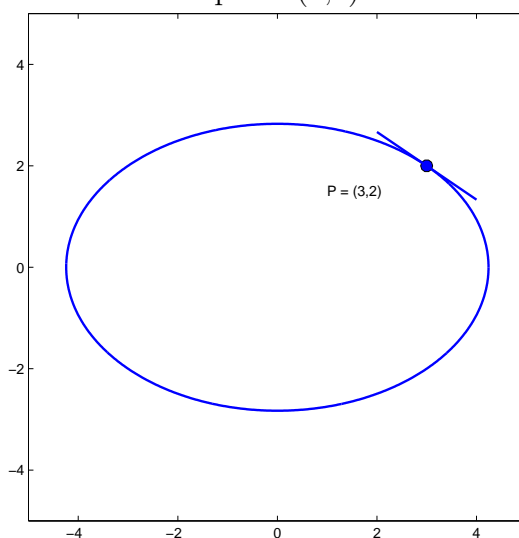

Exercise 4.4.3 Shown Figure Ex. 4.4.3 is the ellipse,

$$\frac{2x^2}{35} + \frac{3y^2}{35} = 1$$

and tangents to the ellipse at (2, 3) and at (4, -1).

- Find the slopes of the tangents.
- Find equations of the tangents.
- Find the point of intersection of the tangents.

Figure for Exercise 4.4.3 Graph of the ellipse $2x^2/35 + 3y^2/35 = 1$ and tangents to the ellipse at the points (2,3) and (4,-1).

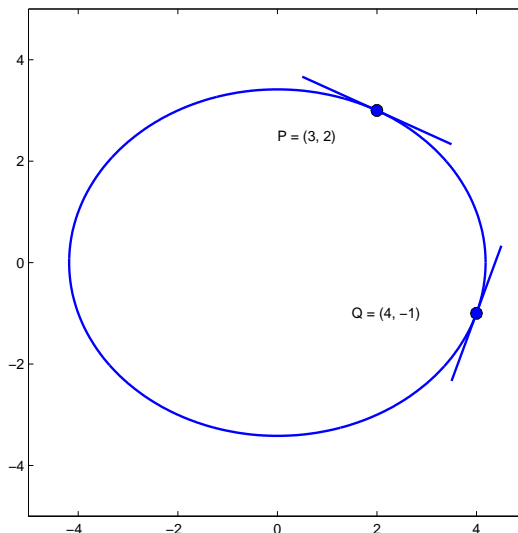

Exercise 4.4.4 Shown in Figure Ex. 4.4.4 is the circle with center at $(2,3)$ and radius 5. find the slope of the tangent to this circle at the point $(5,7)$. An equation of the circle is

$$(x - 2)^2 + (y - 3)^2 = 5^2$$

Figure for Exercise 4.4.4 Graph of the circle $(x - 2)^2 + (y - 3)^2 = 5^2$ and tangent to the circle at the point $(5,7)$.

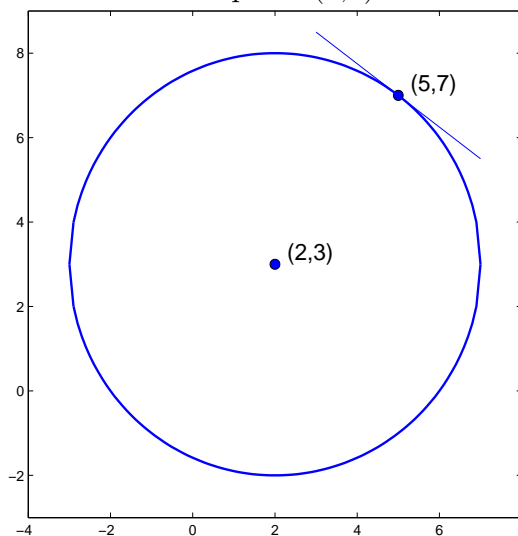

4.5 Some optimization problems.

In Section 3.5.2 we found that local maxima and minima are often points at which the derivative is zero. The algebraic functions for which we can now compute derivatives have only a finite number of points at which the derivative is zero or does not exist and it is usually a simple matter to search among them for the highest or lowest points of their graphs. Such a process has long been used to find optimum parameter values and a few of the traditional problems that can be solved using the derivative rules of this chapter are included here. More optimization problems appear in Chapter 8 Applications of the Derivative.

Assume **for this section only** that all local maxima and local minima of a function, F , are found by computing F' and solving for x in $F'(x) = 0$.

Example 4.5.1 A forester needs to get from point A on a road to point B in a forest (see diagram in Figure 4.4). She can travel 5 km/hr on the road and 3 km/hr in the forest. At what point, P , should she leave the road and enter the forest in order to minimize the time required to travel from A to B ?

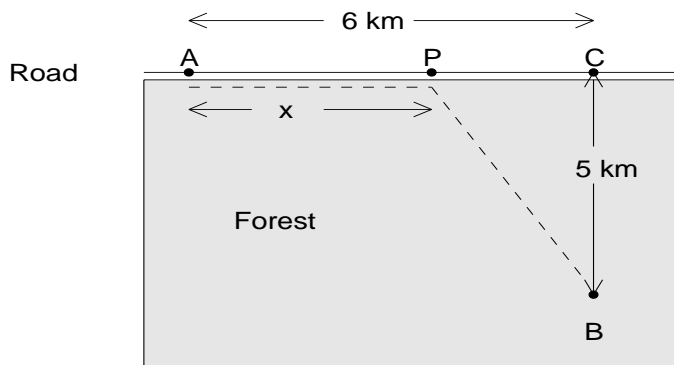

Figure 4.4: Diagram of a forest and adjacent road for Example 4.5.1

Solution. She might go directly from A to B through the forest; she might travel from A to C and then to B ; or she might, as illustrated by the dashed line, travel from A to a point, P , along the road and then from P to B .

Assume that the road is straight, the distance from B to the road is 5 km and the distance from A to the projection of B onto the road (point Q) is 6 km. The point, P , is where the forester leaves the road; let x be the distance from A to P . The basic relation between distance, speed, and time is that

$$\text{Distance (km)} = \text{Speed (km/hr)} \times \text{Time (hr)}$$

so that

$$\text{Time} = \frac{\text{Distance}}{\text{Speed}}$$

The distance traveled and time required are

	Along the road	In the forest
Distance	x	$\sqrt{(6-x)^2 + 5^2}$
Time	$\frac{x}{5}$	$\frac{\sqrt{(6-x)^2 + 5^2}}{3}$

The total trip time, T , is written as

$$T = \frac{x}{5} + \frac{\sqrt{(6-x)^2 + 5^2}}{3} \tag{4.12}$$

A graph of T vs x is shown in Figure 4.5. It appears that the lowest point on the curve occurs at about $x = 2.5$ km and $T = 2.5$ hours. ■

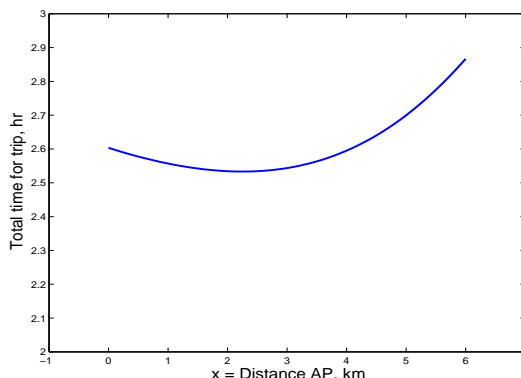

Figure 4.5: Graph of Equation 4.12; total trip time, T , vs distance traveled along the road, x before entering the forest.

Explore 4.5.1 It appears that to minimize the time of the trip, the forester should travel about 2.5 km along the road from A to a point P and enter the forest to travel to B . Observe that the tangent to the graph at the lowest point is horizontal, and that no other point of the graph has a horizontal tangent.

Compute the derivative of $T(x)$ for

$$T(x) = \frac{x}{5} + \frac{\sqrt{(6-x)^2 + 5^2}}{3}$$

Note: The constant denominators may be factored out, as in

$$\left[\frac{x}{5}\right]' = \left[\frac{1}{5}x\right]' = \frac{1}{5}[x]' = \frac{1}{5} \times 1 = \frac{1}{5}$$

You should get

$$T'(x) = \frac{1}{5} + \frac{1}{3} \frac{1}{2} \left((6-x)^2 + 5^2 \right)^{-1/2} \times 2(6-x)(-1)$$

Find the value of x for which $T'(x) = 0$.

Your conclusion should be that the forester should travel 2.25 km from A to P and that the time for the trip, $T(2.25) = 2.53\bar{3}$ hours. ■

Exercises for Section 4.5, Some optimization problems.

Exercise 4.5.1 In Example 4.5.1, what should be the path of the forester if she can travel 10km/hr on the road and 4km/hr in the forest?

Exercise 4.5.2 The air temperature is -10° F and Linda has a ten mile bicycle ride from the university to her home. There is no wind blowing, but riding her bicycle increases the effects of the cold, according to the wind chill chart in Figure 4.5.2 provided by the Centers for Disease Control. The formula for computing windchill is

$$\text{Windchill (F)} = 35.74 + 0.6215 T - 35.75 V^{0.16} + 0.4275 T V^{0.16},$$

where: T = Air Temperature (F) and V = Wind Speed (mph).

Assume that if she travels at a speed, s , then she loses body heat a rate proportional to the difference between her body temperature and wind chill temperature for speed s . (Because no wind is blowing, $V = s$).

- At what speed should she travel in order to minimize the amount of body heat that she loses during the 10 mile bicycle ride?
- Frostbite is skin tissue damage caused by prolonged skin tissue temperature of 23°F . The time for frostbite to occur is also shown in Figure 4.5.2. What is her optimum speed if she wishes to avoid frostbite.
- Discuss her options if the ambient air temperature is -20°F .

Figure for Exercise 4.5.2 Table of windchill temperatures for values of ambient air temperatures and wind speeds provided by the Center for Disease Control at http://emergency.cdc.gov/disasters/winter/pdf/cold_guide.pdf. It was adapted from a more detailed chart at <http://www.nws.noaa.gov/om/windchill>.

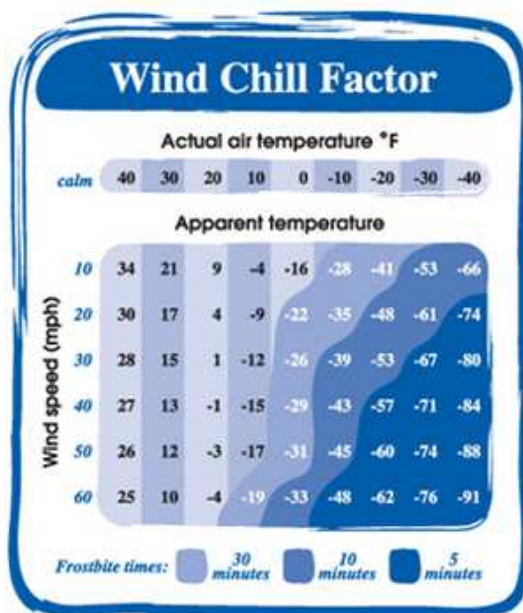

Exercise 4.5.3 If x pounds per acre of nitrogen fertilizer are spread on a corn field, the yield is

$$200 - \frac{4000}{x + 25}$$

bushels per acre. Corn is worth \$6.50 per bushel and nitrogen costs \$0.63 per pound. All other costs of growing and harvesting the crop amount to \$760 per acre, and are independent of the amount of nitrogen fertilizer applied. How much nitrogen per acre should be used to maximize the net dollar return per acre? Note: The parameters of this problem are difficult to keep up to date.

Exercise 4.5.4 Optimum cross section of your femur. R. M. Alexander³ has an interesting analysis of the cross section of mammal femurs. Femurs are hollow tubes filled with marrow. They should resist forces that tend to bend them, but not be so massive as to impair movement. An

³R. McNeil Alexander, *Optima for Animals*, Princeton University Press, Princeton, NJ, 1996, Section 2.1, pp 17-22.

optimum femur will be the lightest bone that is strong enough to resist the maximum bending moment, M , that will be applied to it during the life of the animal.

A hollow tube of mass m kg/m may be stronger than a solid rod of the same weight, depending on two parameters of the tube, the outside radius, R , and the inside radius, $x \times R$ ($0 \leq x < 1$), see Figure 4.6. For a given moment, M , the relation between R and x is

$$R = \left[\frac{M}{K(1-x^4)} \right]^{\frac{1}{3}} = \left(\frac{M}{K} \right)^{\frac{1}{3}} (1-x^4)^{-\frac{1}{3}} \quad (4.13)$$

The constant K describes the strength of the material.

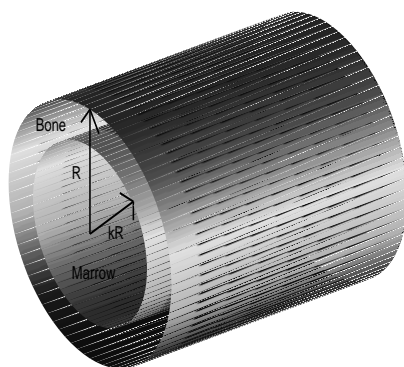

Figure 4.6: Consider a femur to be a tube of radius R with solid bone between kR and R and marrow inside the tube of radius kR .

Let ρ be bone density and assume marrow density is $\frac{1}{2}\rho$. Then the mass per unit length of bone, m_b , is

$$\begin{aligned} m_b &= \rho \times (\pi R^2 - \pi(R \times x)^2) \\ &= \rho \pi (1 - x^2) R^2 \\ &= \rho \pi \left(\frac{M}{K} \right)^{\frac{2}{3}} (1 - x^2) (1 - x^4)^{-\frac{2}{3}} \end{aligned} \quad (4.14)$$

- Write an equation for the mass per unit length of the bone marrow similar to Equation 4.14.
- Let m be total mass per unit length; the sum of m_b and the mass per unit length of marrow. We would like to know the derivative of m with respect to x for

$$m = C \left(\left(1 - \frac{1}{2}x^2\right) (1 - x^4)^{-\frac{2}{3}} \right). \quad C = \rho \pi \left(\frac{M}{K} \right)^{\frac{2}{3}} \quad (4.15)$$

You will see in Chapter 6 that

$$[m]' = C \left(\left[1 - \frac{1}{2}x^2\right]' \times (1 - x^4)^{-\frac{2}{3}} + \left(1 - \frac{1}{2}x^2\right) \times \left[(1 - x^4)^{-\frac{2}{3}}\right]' \right)$$

Finish the computation of $[m]'$ and simplify the expression.

- c. Find a value of \bar{x} for which $x = \bar{x}$ yields $m' = 0$.

$$-x(1-x^4)^{-\frac{2}{3}} + \frac{8}{3}x^3\left(1 - \frac{1}{2}x^2\right)(1-x^4)^{-\frac{5}{3}} = 0$$

- d. The value \bar{x} computed in Part c. is the x -coordinate of the lowest point of the graph of m shown in Exercise Figure 4.5.4. Alexander shows the values for x for five mammalian species; for the humerus they range from 0.42 to 0.66 and for the femur they range from 0.54 to 0.63. Compare \bar{x} with these values.
- e. Exercise Figure 4.5.4B is a cross section of the human leg at mid-thigh. Estimate x for the femur.

Alexander modifies this result, noting that Equation 4.13 is the breaking moment, and a bone with walls this thin would buckle before it broke, and noting that bones are tapered rather than of uniform width.

Figure for Exercise 4.5.4

A. Graph of Equation 4.15, m , the mass of bone plus marrow, as a function of the ratio, x . Mass per unit length of a solid bone has been arbitrarily set equal to one. B. Cross section of a human leg at mid thigh. http://en.wikipedia.org/wiki/Fascial_compartments_of_thigh. Lithograph plate from Gray's Anatomy, not copyrightable.

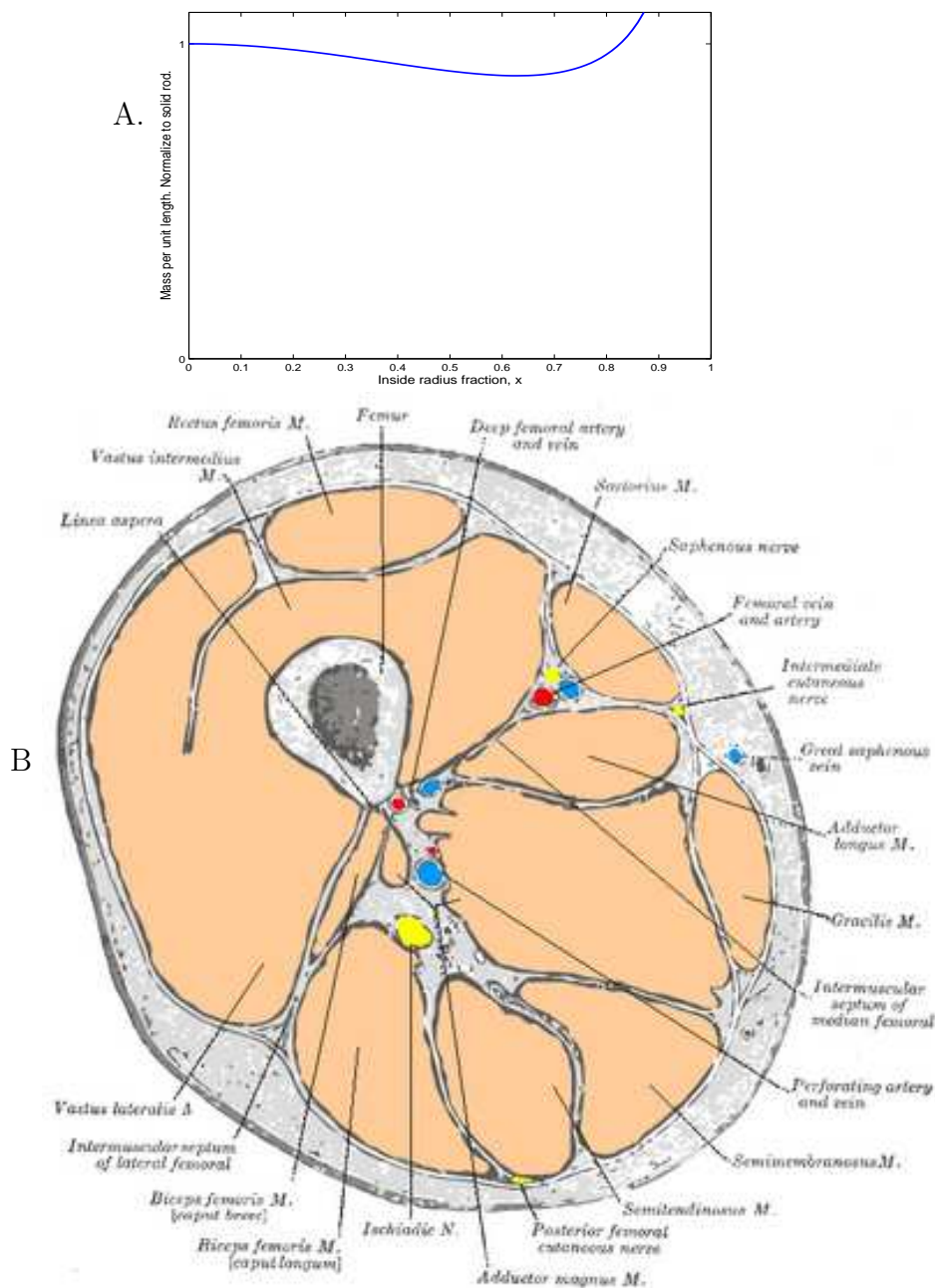

4.6 Implicit differentiation.

In Section 4.4, Applications of the Power Chain Rule, we found slopes of circles and ellipses. There is a procedure for finding these slopes that requires less algebra, but more mathematical sophistication. In each of the equations,

$$x^2 + y^2 = 13$$

$$\frac{x^2}{18} + \frac{y^2}{8} = 1$$

$$\frac{2x^2}{35} + \frac{3y^2}{35} = 1$$

we might solve for y in terms of x , being careful to choose the correct square root to match the point of tangency, and then compute $y'(x)$.

In $x^2 + y^2 = 13$, we may choose $y(x) = \sqrt{13 - x^2}$. Note that

$$x^2 + y^2 = x^2 + (\sqrt{13 - x^2})^2 = x^2 + 13 - x^2 = 13$$

so that $y(x) = \sqrt{13 - x^2}$ is a function that ‘satisfies’ and is said to be *implicitly* defined by the equation.

Definition 4.6.1 Implicit Function. *Suppose we are given an equation*

$$E(x, y) = 0$$

and point (a, b) for which

$$E(a, b) = 0$$

A function, f , defined on an interval $(a - h, a + h)$ surrounding a and satisfying

$$E(x, f(x)) = 0 \quad \text{and} \quad f(a) = b$$

is said to be implicitly defined by E . There may be no such function, f , one such function, or many such functions.

Now we assume without solving for $y(x)$ that there is a function $y(x)$ for which

$$x^2 + (y(x))^2 = 13 \quad \text{and} \quad y(2) = 3,$$

and use the power rule and power chain rule to differentiate the terms in the equation, as follows.

$$x^2 + (y(x))^2 = 13$$

$$[x^2]' + [(y(x))^2]' = [13]'$$

$$2x + 2y(x)y'(x) = 0$$

The **power rule** is used for

$$[x^2]' = 2x$$

The **power chain rule** is used for

$$[(y(x))^2]' = 2y(x)y'(x)$$

We use $x = 2$ and $y(2) = 3$ in the last equation to get

$$2 \times 2 + 2 \times 3 y'(2) = 0$$

and solve for $y'(2)$ to get

$$y'(2) = -\frac{2}{3}$$

as was found in Example 4.4.1 to be the slope of the tangent to $x^2 + y^2 = 13$ at $(2,3)$.

It is important to remember in the above steps the $[\quad]'$ means derivative with respect to the independent variable, x . The Leibnitz notation, $\frac{d}{dx}$, explicitly shows this and may be easier to use. We repeat this problem with Leibnitz notation.

$$x^2 + (y(x))^2 = 13$$

$$\frac{d}{dx}(x^2) + \frac{d}{dx}(y(x))^2 = \frac{d}{dx}(13)$$

$$2x + 2y(x)\frac{d}{dx}y(x) = 0$$

The **power rule** is used for

$$\frac{d}{dx}(x^2) = 2x$$

The **power chain rule** is used for

$$\frac{d}{dx}(y(x))^2 = 2y(x)\frac{d}{dx}y(x)$$

Example 4.6.1 We consider another example of implicit differentiation. Find the slope of the graph of

$$\sqrt{x} + \sqrt{5 - y^2} = 5 \quad \text{at } (9,1) \text{ and at } (4,2)$$

First we check to see that $(9,1)$ satisfies the equation:

$$\sqrt{9} + \sqrt{5 - 1^2} = \sqrt{9} + \sqrt{4} = 3 + 2 = 5. \quad \text{It checks.}$$

Then we assume there is a function $y(x)$ such that

$$\sqrt{x} + \sqrt{5 - (y(x))^2} = 5 \quad \text{and that} \quad y(9) = 1.$$

We convert the square root symbols to fractional exponents and differentiate using Leibnitz

notation.

$$\begin{aligned}
 x^{\frac{1}{2}} + (5 - (y(x))^2)^{\frac{1}{2}} &= 5 \\
 \frac{d}{dx} \left(x^{\frac{1}{2}} + (5 - (y(x))^2)^{\frac{1}{2}} \right) &= \frac{d}{dx} 5 \\
 \frac{d}{dx} x^{\frac{1}{2}} + \frac{d}{dx} (5 - (y(x))^2)^{\frac{1}{2}} &= 0 && \text{Sum and Constant Rules} \\
 \frac{1}{2} x^{-\frac{1}{2}} + \frac{1}{2} (5 - y^2)^{-\frac{1}{2}} \frac{d}{dx} (5 - (y(x))^2) &= 0 && \text{Power and Power Chain Rules} \\
 \frac{1}{2} x^{-\frac{1}{2}} + \frac{1}{2} (5 - y^2)^{-\frac{1}{2}} \left(\frac{d}{dx} 5 - \frac{d}{dx} (y(x))^2 \right) &= 0 && \text{Sum Rule} \\
 \frac{1}{2} x^{-\frac{1}{2}} + \frac{1}{2} (5 - y^2)^{-\frac{1}{2}} \left(0 - 2y \frac{d}{dx} y(x) \right) &= 0 && \text{Constant and Power Chain Rules}
 \end{aligned}$$

Next we solve for $\frac{d}{dx}y(x)$ and get

$$\frac{d}{dx}y(x) = \frac{\sqrt{5 - y^2}}{2yx^{\frac{1}{2}}} \quad \text{and evaluate at } (9,1) \quad \left. \frac{\sqrt{5 - y^2}}{2yx^{\frac{1}{2}}} \right|_{(x,y)=(9,1)} = \frac{1}{3}$$

So the slope of the graph at (9,1) is 1/3. You may notice that we have selectively used $y(x)$ and y ; often only y is used to simplify notation.

An equation of the tangent to the graph of $\sqrt{x} + \sqrt{5 - y^2} = 5$ at the point (9,1) is $y - 1 = \frac{1}{3}(x - 9)$.

Now for the point (4,2), the differentiation is exactly the same and we might (**alert!**) evaluate

$$\frac{d}{dx}y(x) = \frac{\sqrt{5 - y^2}}{2yx^{\frac{1}{2}}} \quad \text{at } (4,2) \quad \left. \frac{\sqrt{5 - y^2}}{2yx^{\frac{1}{2}}} \right|_{(x,y)=(4,2)} = \frac{1}{8}$$

However, the point (4,2) **does not satisfy the original equation** and is not a point of its graph. Finding the slope at that point is meaningless, so we punt.

All of this solution is algebraic. The graph of the equation shown in Figure 4.7 is of considerable help. ■

Exercises for Section 4.6 Implicit Differentiation.

Exercise 4.6.1 For those points that are on the graph, find the slopes of the tangents to the graph of

a. $\frac{x^2}{18} + \frac{y^2}{8} = 1$ at the points (3, 2) and (-3, 2)

b. $\frac{2x^2}{35} + \frac{3y^2}{35} = 1$ at the points (4, 1), (-3, -2), and (4, -1)

Exercise 4.6.2 Find the slope of the graph of $\sqrt{x} - \sqrt{5 - y^2} = 5$ at the point (36,-2). Is there a slope to the graph at the point (46,1)?

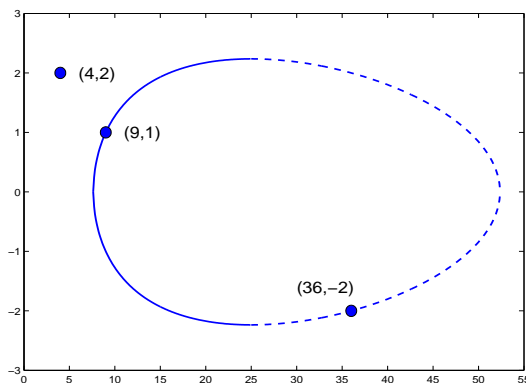

Figure 4.7: Solid curve: Graph of $\sqrt{x} + \sqrt{5 - y^2} = 5$ and the points (9,1) and (4,2) for Example 4.6.1. Dashed curve: Graph of $\sqrt{x} - \sqrt{5 - y^2} = 5$ and the point (36,-2) for Exercise 4.6.2.

Exercise 4.6.3 A Finnish landscape architect laid out gardens in the shape of the pseudo ellipsoid

$$\frac{|x|^{2.5}}{a^{2.5}} + \frac{|y|^{2.5}}{b^{2.5}} = 1$$

a shape that became commonly used in design of Scandinavian furniture and table ware. In Figure Ex. 4.6.3 is the graph of,

$$\frac{|x|^{2.5}}{3^{2.5}} + \frac{|y|^{2.5}}{2^{2.5}} = 1$$

and tangents drawn at (2, 1.67) and (-1.5, 1.85). Find the slopes of the tangents.

Figure for Exercise 4.6.3 Graph of the equation $|x|^{2.5}/3^{2.5} + |y|^{2.5}/2^{2.5} = 1$ representative of a Scandinavian design.

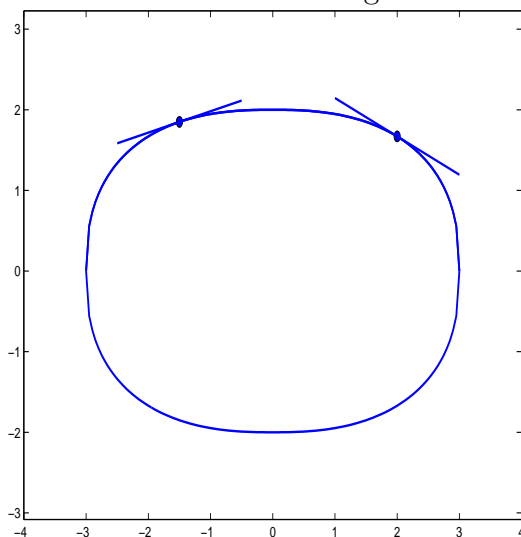

Exercise 4.6.4 Draw the graph and find the slopes of the tangents to the graph of

- a. $x^2 - 2y^2 = 1$ at the points $(3, 2)$ and $(-3, -2)$
- b. $2x^4 + 3y^4 = 35$ at the points $(2, 1)$, $(1, -2)$, and $(2, -1)$
- c. $\sqrt{|x|} + \sqrt{|y|} = 5$ at the points $(9, 4)$ and $(1, -16)$
- d. $\sqrt{x} + \sqrt[3]{y} = 9$ at the points $(64, 1)$, $(36, 27)$, and $(16, 125)$
- e. $x^2 + y^2 = (x + y)^2$ at the points $(1, 0)$ and $(0, 1)$
- f. $(x^2 + 4)y = 24$ at the points $(2, 3)$ and $(0, 6)$
- g. $x^3 + y^3 = (x + y)^3$ at the points $(1, -1)$ and $(-2, 0)$
- h. $x^4 + x^2y^2 = 20y^2$ at the points $(2, 1)$ and $(2, -1)$

Exercise 4.6.5 This is an interesting and challenging problem. The goal is to explain, among other things, the historical instance of John Adams overhearing the plans of his opponents in Statuary Hall just outside the U.S. congressional chamber.

Ellipses have an interesting reflective property explained by tangents to an ellipse (see Figure 4.8A). Light or sound originating at one focal point of an ellipse is reflected by the ellipse to the other focal point. Statuary Hall is in the shape of an ellipse. John Adams opponents had a desk at one of the focal points and Adams arranged to stand at the other focal point. This property also is a factor in the acoustics of the Mormon Tabernacle in Salt Lake City, Utah and the Smith Civil War Memorial in Philadelphia, Pennsylvania.

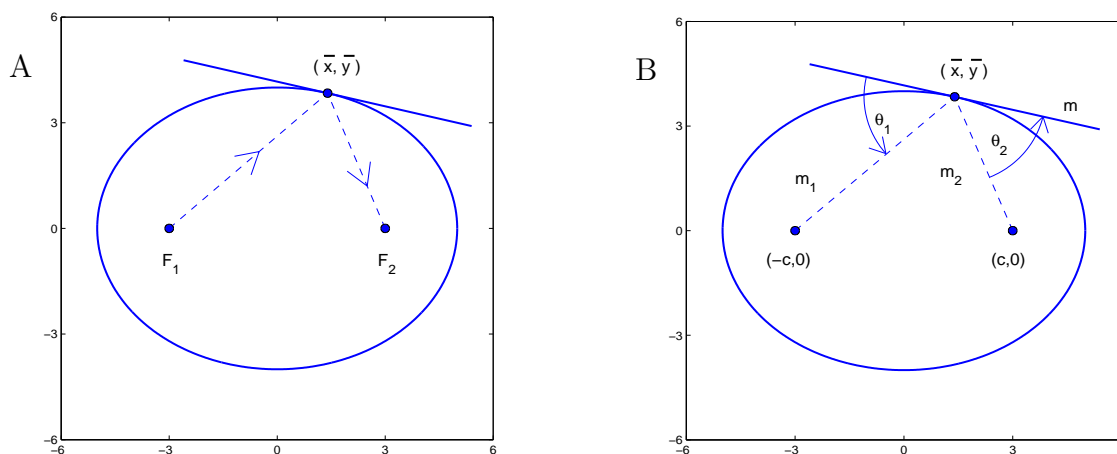

Figure 4.8: A. An ellipse. Light or sound originating at focal point F_1 and striking the ellipse at (\bar{x}, \bar{y}) is reflected to F_2 . B. The angle of incidence, θ_1 , is equal to the angle of reflection, θ_2 .

In case you have forgotten: For two intersecting lines with inclinations α_1 and α_2 and $\alpha_1 > \alpha_2$ and slopes $m_1 = \tan \alpha_1$ and $m_2 = \tan \alpha_2$, one of the angles between the two lines is $\theta = \alpha_1 - \alpha_2$ (Figure 4.9). If neither line is vertical and the lines are not perpendicular,

$$\tan \theta = \tan(\alpha_1 - \alpha_2) = \frac{\tan \alpha_1 - \tan \alpha_2}{1 + \tan \alpha_1 \tan \alpha_2} = \frac{m_1 - m_2}{1 + m_1 m_2} \tag{4.16}$$

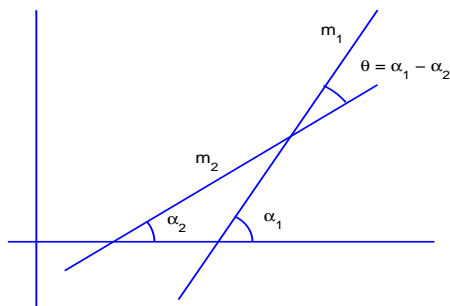

Figure 4.9: Two lines with inclinations α_1 and $\alpha_2 < \alpha_1$ and slopes m_1 and m_2 . An angle of intersection is $\theta = \alpha_1 - \alpha_2$.

Refer to Figure 4.8B. Assume an equation of the ellipse is $b^2x^2 + a^2y^2 = a^2b^2$, $a > b > 0$. Then the focal points will be at $(-c, 0)$ and $(c, 0)$ where $c = \sqrt{a^2 - b^2}$. Let (\bar{x}, \bar{y}) denote a point of the ellipse. In order to establish the reflective property of ellipses, it is sufficient to show that the angle of incidence, θ_1 is equal to the angle of reflection, θ_2 .

- Find the slope, m , of the tangent at (\bar{x}, \bar{y}) .
- Show that

$$\tan \theta_1 = \frac{\frac{\bar{y}}{\bar{x} + c} - \left(-\frac{b^2 \bar{x}}{a^2 \bar{y}}\right)}{1 + \frac{\bar{y}}{\bar{x} + c} \left(-\frac{b^2 \bar{x}}{a^2 \bar{y}}\right)}$$

- Write a similar expression for $\tan \theta_2$.
- For the algebraically bold.** Show that $\tan \theta_1 = \tan \theta_2$.
- Both tangents are positive, both angles are acute, and the angles are equal.

4.7 Summary of Chapter 4

We have defined *continuity* of a function, shown that if a function F has a derivative at a point x in its domain then F is continuous at x , and used this property to prove the Power Chain Rule,

$$\text{PCR:} \quad [u^n(t)]' = n u^{n-1}(t) \times u'(t).$$

We proved PCR for all positive integers, n . In Exercises 4.3.3 and 4.3.4 you showed PCR to be true for all rational numbers, n . In fact, PCR is true for all numbers, n . We then used the power chain rule to solve some problems.

Exercises for Chapter 4, Continuity and the Power Chain Rule.

Chapter Exercise 4.7.1 Compute the derivative of P .

$$\begin{array}{lll}
 \text{a. } P(t) = 3t^2 - 2t + 7 & \text{b. } P(t) = t + \frac{2}{t} & \text{c. } P(t) = \sqrt{t+2} \\
 \text{d. } P(t) = (t^2 + 1)^5 & \text{e. } P(t) = \sqrt{2t+1} & \text{f. } P(t) = 2t^{-3} - 3t^{-2} \\
 \text{g. } P(t) = \frac{5}{t+5} & \text{h. } P(t) = (1 + \sqrt{t})^{-1} & \text{i. } P(t) = (1 + 2t)^5 \\
 \text{j. } P(t) = (1 + 3t)^{1/3} & \text{k. } P(t) = \frac{1}{1 + \sqrt{t}} & \text{l. } P(t) = \sqrt[3]{1 + 2t}
 \end{array}$$

Chapter Exercise 4.7.2 In “Natural History”, March, 1996, Neil de Grass Tyson discusses the discovery of an astronomical object called a “brown dwarf”.

”We have suspected all along that brown dwarfs were out there. One reason for our confidence is the fundamental theorem of mathematics that allows you to declare that if you were once 3’8” tall and are now 5’8” tall, then there was a moment when you were 4’8” tall (or any other height in between). An extension of this notion to the physical universe allows us to suggest that if round things come in low-mass versions (such as planets) and high-mass versions (such as stars) then there ought to be orbs at all masses in between *provided a similar physical mechanism made both*.

What fundamental theorem of mathematics is being referenced in the article about the astronomical objects called brown dwarfs? What implicit assumption is being made about the sizes of astronomical objects? (For future consideration: Is the number of ‘orbs’ countable?)

Chapter Exercise 4.7.3 In a square field with sides of length 1000 feet that are already fenced a farmer wants to fence two rectangular pens of equal area using 400 feet of new fence and the existing fence around the field. What dimensions of lots will maximize the area of the two pens?

Chapter Exercise 4.7.4 You must cross a river that is 50 meters wide and reach a point on the opposite bank that is 1 km up stream. You can travel 6 km per hour along the river bank and 1 km per hour in the river. Describe a path that will minimize the amount of time required for your trip. Neglect the flow of water in the river.

Chapter Exercise 4.7.5 Find the point of intersection of the tangents to the ellipse $x^2/224 + y^2/128 = 1/7$ at the points $(2,4)$ and $(5,-2)$.

Chapter 5

Derivatives of Exponential and Logarithmic Functions

Where are we going?

In this chapter you will learn how to compute the rates of change of exponential and logarithmic functions, for example $y = 2^x$ and $y = \log_{10} x$.

You will find a preferred number, $e \doteq 2.71828$, for which the derivatives of the exponential function $y = e^x$ and the logarithm function $y = \log_e x$ (denoted by $\ln x$) are very simple.

We continue the use of rate of change to model biological and physical processes. The derivatives of exponential and logarithm functions greatly expand the class of biological processes that we describe with equations.

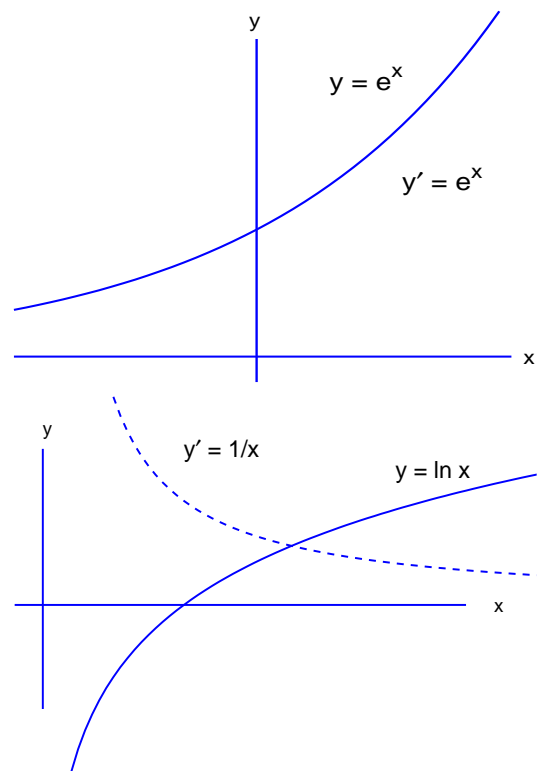

5.1 Derivatives of Exponential Functions.

Exponential functions are often used to describe the growth or decline of biological populations, distribution of enzymes over space, and other biological and chemical relations. The rate of change of exponential functions describes population growth rate, decay of chemical concentration with space, and rates of change of other biological and chemical processes.

The exponential function $E(t) = 2^t$ (where the base is 2 and the exponent is t) is quite different from the algebraic function, $P(t) = t^2$ (where the base is t and the exponent is 2). $P(t) = t^2$ is well defined for all numbers t in terms of multiplication, $P(t) = t \times t$. However, in elementary courses 2^t is defined only for t a rational number. For the irrational number $\sqrt{2} = 1.4142135 \dots$, for example,

$2^{\sqrt{2}}$ is the number to which the sequence $2^{1.4}, 2^{1.41}, 2^{1.414}, 2^{1.4142}, \dots$ approaches. We will not formalize this idea, but will assume that 2^t is meaningful for all numbers t .

Shown in Table 5.1 are computations and a graph directed to finding the rate of growth of $E(t) = 2^t$ at $t = 2$. We wish to find a number m_2 so that

$$\lim_{b \rightarrow 2} \frac{2^b - 2^2}{b - 2} = m_2.$$

Table 5.1: Table and Graph of $E(t) = 2^t$ near $t = 2$.

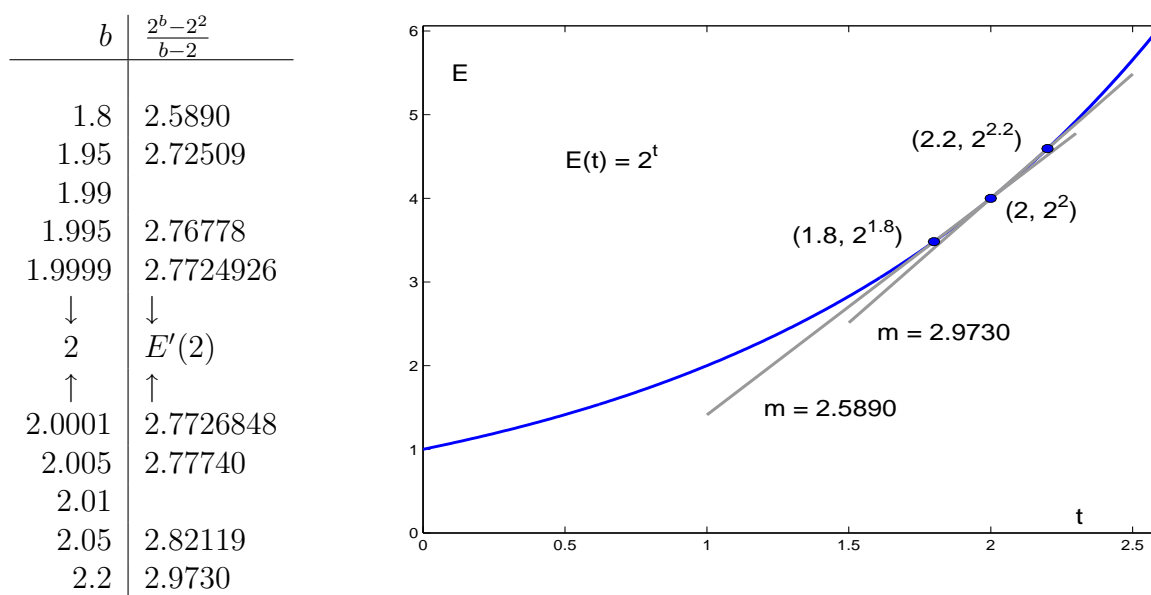

Explore 5.1.1 Compute the two entries corresponding to $b = 1.99$ and $b = 2.01$ that are omitted from Table 5.1. ■

Within the accuracy of Table 5.1, you may conclude that m_2 should be between 2.7724926 and 2.7726848. The average of 2.7724926 and 2.7726848 is a good estimate of m_2 .

$$\frac{m_{[2,1.9999]} + m_{[2,2.0001]}}{2} = \frac{2.7724926 + 2.7726848}{2} = 2.7725887$$

We will find in Example ?? that correct to 11 digits, the rate of growth of $E(t)$ at $t = 2$ is 2.7725887222. As approximations to $E'(2)$, 2.7724926 and 2.7726848 are correct to only five digits, but their average, 2.7725887, is correct to all eight digits shown. Such improvement in accuracy by averaging left and right difference quotients (defined next) is common.

For P a function, the fraction,

$$\frac{P(b) - P(a)}{b - a},$$

is called a *difference quotient* for P . If $h > 0$ then the backward, and centered, and forward difference quotients at a are

Backward	Centered	Forward
$\frac{P(a) - P(a - h)}{h}$	$\frac{P(a + h) - P(a - h)}{2h}$	$\frac{P(a + h) - P(a)}{h}$

Assuming the interval size h is the same in all three, the centered difference quotient is the average of the backward and forward difference quotients.

$$\begin{aligned} \frac{\frac{P(a-h) - P(a)}{-h} + \frac{P(a+h) - P(a)}{h}}{2} &= \frac{\frac{-P(a-h) + P(a)}{h} + \frac{P(a+h) - P(a)}{h}}{2} \\ &= \frac{-P(a-h) + P(a) + P(a+h) - P(a)}{2h} \\ &= \frac{P(a+h) - P(a-h)}{2h} \end{aligned} \tag{5.1}$$

The graphs in Figure 5.1 suggest, and it is generally true, that the centered difference quotient is a better approximation to the slope of the tangent to P at $(a, P(a))$ than is either the forward or backward difference quotients. Formal analysis of the errors in the two approximations appears in Example 12.7.3, Equations 12.22 and 12.23. We will use the centered difference quotient to approximate $E'(a)$ throughout this chapter.

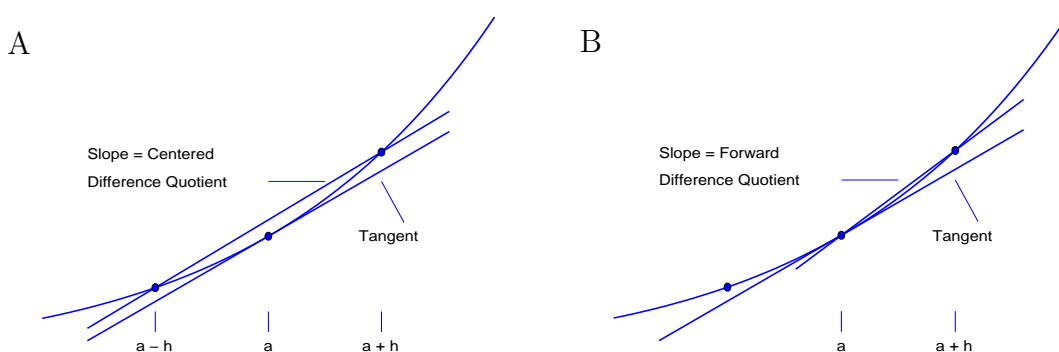

Figure 5.1: The centered difference quotient shown in A is closer to the slope of the tangent at $(a, f(a))$ than is the forward difference quotient shown in B.

Using the centered difference approximation, we approximate $E'(t)$ for $E(t) = 2^t$ and five different value of t , $-1, 0, 1, 2$, and 3 .

	Centered diff quot	$E'(t) \doteq$	$E'(t)$	$E(t)$
$E'(-1)$	$\doteq \frac{2^{-1+0.0001} - 2^{-1-0.0001}}{0.0002}$	$= 0.34657359$	0.35	$\frac{1}{2}$
$E'(0)$	$\doteq \frac{2^{0+0.0001} - 2^{0-0.0001}}{0.0002}$	$= 0.69314718$	0.69	1
$E'(1)$	$\doteq \frac{2^{1+0.0001} - 2^{1-0.0001}}{0.0002}$	$= 1.3862944$	1.39	2
$E'(2)$	$\doteq \frac{2^{2+0.0001} - 2^{2-0.0001}}{0.0002}$	$= 2.7725887$	2.77	4
$E'(3)$	$\doteq \frac{2^{3+0.0001} - 2^{3-0.0001}}{0.0002}$	$= 5.5451774$	5.55	8

Explore 5.1.2 Do This. An elegant pattern emerges from the previous computations. To help you find it the last two columns contain truncated approximations to $E'(t)$ and the values of $E(t)$. Spend at least two minutes looking for the pattern (or less if you find it). ■

The pattern we hope you see is that

$$E'(t) \doteq E'(0) E(t)$$

We will soon show that for $E(t) = 2^t$, $E'(t) = E'(0) E(t)$, exactly. Meanwhile we observe that $E'(0) \doteq 0.69314718$ and

$$E'(0) E(-1) \doteq 0.69314718 \frac{1}{2} = 0.34657359 \doteq E'(-1),$$

$$E'(0) E(1) \doteq 0.69314718 \times 2 = 1.38629436 \doteq E'(1),$$

$$E'(0) E(2) \doteq 0.69314718 \times 4 = 2.77258872 \doteq E'(2), \quad \text{and}$$

$$E'(0) E(3) \doteq 0.69314718 \times 8 = 5.54517744 \doteq E'(3),$$

which supports the pattern.

Explore 5.1.3 Let $E(t) = 3^t$. Use the centered difference quotient to approximate $E'(t)$ for $t = -1, 0, 1, 2, 3$. Test your numbers to see whether $E'(t) \doteq E'(0) E(t)$. ■

The previous work suggests a general rule:

Theorem 5.1.1 If $E(t) = B^t$ where $B > 0$, then

$$E'(t) = E'(0) E(t). \quad (5.2)$$

Proof: For $E(t) = B^t$, $B > 0$,

$$\begin{aligned} E'(t) &= \lim_{h \rightarrow 0} \frac{B^{t+h} - B^t}{h} = \lim_{h \rightarrow 0} \frac{B^t B^h - B^t}{h} = \lim_{h \rightarrow 0} \frac{B^t (B^h - 1)}{h} \\ &= B^t \lim_{h \rightarrow 0} \frac{B^h - B^0}{h} = E(t) E'(0) \end{aligned}$$

End of proof.

The preceding argument follows the pattern of all computations of derivatives using Definition 3.23. We write the difference quotient, $\frac{F(t+h)-F(t)}{h}$, balance h in the denominator with some term in the numerator, and let $h \rightarrow 0$. In Chapters 3 and 4 we always could factor an h from

the numerator that algebraically canceled the h in the denominator. In this case, there is no factor, h , in the numerator, but

$$\text{as } h \rightarrow 0, \quad \frac{B^h - B^0}{h} \rightarrow E'(0),$$

and h in the denominator is neutralized (**even though we do not yet know $E'(0)$**).

Exercises for Section 5.1 Derivatives of Exponential Functions.

Exercise 5.1.1 (a) Compute the centered difference

$$\frac{P(a+h) - P(a-h)}{2h},$$

which is an approximation to $P'(a)$, for $P(t) = t^2$ and compare your answer with $P'(a)$.

(b) Compute the centered difference

$$\frac{P(a+h) - P(a-h)}{2h}$$

for $P(t) = 5t^2 - 3t + 7$ and compare your answer with $P'(a)$.

Exercise 5.1.2 Technology Sketch the graphs of $y = 2^t$ and $y = 4 + 2.7725887(t - 2)$

- Using a window of $0 \leq x \leq 2.5$, $0 \leq y \leq 6$.
- Using a window of $1.5 \leq x \leq 2.5$, $0 \leq y \leq 6$.
- Using a window of $1.8 \leq x \leq 2.2$, $3.3 \leq y \leq 4.6$.

Mark the point $(2,4)$ on each graph.

Exercise 5.1.3 Let $E(t) = 10^t$.

- Approximate $E'(0)$ using the centered difference quotient on $[-0.0001, 0.0001]$.
- Use your value for $E'(0)$ and $E'(t) = E'(0) E(t)$ to approximate $E'(-1)$, $E'(1)$, and $E'(2)$.
- Sketch the graphs of $E(t)$ and $E'(t)$.
- Repeat a., b., and c. for $E(t) = 8^t$.

Exercise 5.1.4 Let $E(t) = \left(\frac{1}{2}\right)^t$.

- Approximate $E'(0)$ using the centered difference quotient on $[-0.0001, 0.0001]$.
- Use your value for $E'(0)$ and $E'(t) = E'(0) E(t)$ to approximate $E'(-1)$, $E'(1)$, and $E'(2)$.
- Sketch the graphs of $E(t)$ and $E'(t)$.

Exercise 5.1.5 Find (approximately) equations of the lines tangent to the graphs of

- $y = 1.5^t$ at the points $(-1, 2/3)$, $(0, 1)$, and $(1, 3/2)$
- $y = 2^t$ at the point $(-1, 1/2)$, $(0, 1)$, and $(1, 2)$
- $y = 3^t$ at the point $(-1, 1/3)$, $(0, 1)$, and $(1, 3)$
- $y = 5^t$ at the point $(-1, 1/5)$, $(0, 1)$, and $(1, 5)$

Exercise 5.1.6 Suppose a bacterium *Vibrio natriegens* is growing in a beaker and cell concentration C at time t in minutes is given by

$$C(t) = 0.87 \times 1.02^t \quad \text{million cells per ml}$$

- Approximate $C(t)$ and $C'(t)$ for $t = 0, 10, 20, 30$, and 40 minutes.
- Plot a graph of $C'(t)$ vs $C(t)$ using the five pairs of values you just computed.

Exercise 5.1.7 Suppose penicillin concentration in the serum of a patient t minutes after a bolus injection of 2 g is given by

$$P(t) = 200 \times 0.96^t \quad \mu\text{g/ml}$$

- Approximate $P(t)$ and $P'(t)$ for $t = 0, 5, 10, 15$, and 20 minutes.
- Plot a graph of $P'(t)$ vs $P(t)$ using the five pairs of values you just computed.

5.2 The number e .

The implication

$$\text{For } E(t) = B^t \quad \implies \quad E'(t) = E'(0) \times E(t)$$

would be even simpler if we find a value for B so that $E'(0) = 1$. We next find such a value for B . It is universally denoted by e and

e is approximately 2.71828182845904523536 ; e is not a rational number.

Then for $E(t) = e^t$, $E'(0) = 1$ so that $E'(t) = E'(0) E(t) = 1 \times E(t) = e(t)$.

Thus $[e^t]' = e^t$, a very important result.

Our goal is to find a base, e , so that

$$[e^t]' \Big|_{t=0} = 1$$

Because

$$[2^t]' \Big|_{t=0} \doteq 0.69341 \quad \text{and} \quad [3^t]' \Big|_{t=0} \doteq 1.098612,$$

we think the base e that we seek is between 2 and 3 and perhaps closer to 3 than to 2.

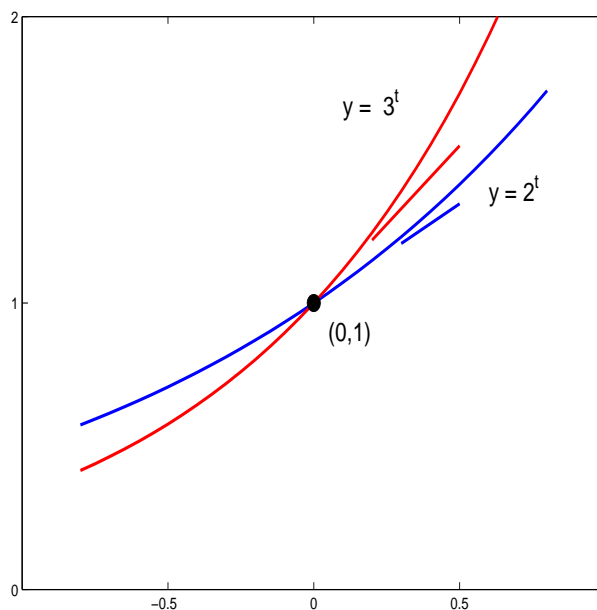

Figure 5.2: Graphs of exponential functions, $y = 2^t$, and $y = 3^t$ and segments of the tangents for each. The tangents have slopes approximately 0.69341 and 1.098612, respectively.

Explore 5.2.1

$$\left[e^t \right]' \Big|_{t=0} = 1 \quad \text{and} \quad e^t \Big|_{t=0} = 1,$$

and the line of slope 1 through $(0,1)$ is tangent to the graph of $y = e^t$. Draw a line of slope 1 through the point $(0,1)$. Then draw a graph of an exponential function whose tangent at $(0,1)$ is the line you drew. Compare your graph with those in Figure 5.2. ■

Assuming that

$$\left[e^t \right]' \Big|_{t=0} = 1, \quad \text{it must be that} \quad \lim_{h \rightarrow 0} \frac{e^h - e^0}{h} = \lim_{h \rightarrow 0} \frac{e^h - 1}{h} = 1.$$

Intuitively then, for h close to zero,

$$\frac{e^h - 1}{h} \doteq 1, \quad e^h - 1 \doteq h, \quad e^h \doteq 1 + h, \quad e \doteq (1 + h)^{\frac{1}{h}}$$

We will use this to explore e , and in Subsection 5.2.1 we will find that

$$e = \lim_{h \rightarrow 0} (1 + h)^{\frac{1}{h}}. \tag{5.3}$$

Values of $(1 + h)^{\frac{1}{h}}$ for progressively smaller values of h are shown in Table 5.2. As $h > 0$ decreases toward 0, $(1 + h)^{\frac{1}{h}}$ increases. We show in Subsection 5.2.1 that $(1 + h)^{\frac{1}{h}}$ approaches a number as h approaches 0, and we denote that number by e .

Explore 5.2.2 Compute $A = (1 + h)^{1/h}$ for $h = 0.0001$, $h = 0.00001$, and $h = 0.000001$. ■

Your last estimate of A should be approximately 2.71828047, which is an estimate correct to 6 digits of the irrational number e that we are seeking.

Table 5.2: Approximations to the number e . As h moves toward 0, $A = (1 + h)^{1/h}$ increases toward e .

h	$A = (1 + h)^{1/h}$
1.000	2.00000
0.500	2.25000
0.200	2.48832
0.100	2.59374
0.050	2.65329
0.010	2.70481
0.005	2.71152
0.001	2.71692
↓	↓
0	e

Definition 5.2.1 The number e The number e is defined by

$$\lim_{h \rightarrow 0} (1 + h)^{\frac{1}{h}} = e$$

Correct to 21 digits, $e = 2.71828\ 18284\ 59045\ 23536$

We show in Subsection 5.2.1 that if $h = \frac{1}{n}$ for n an integer greater than 2

$$(1 + h)^{\frac{1}{h}} < e < \left(1 + \frac{h}{1 - h}\right)^{\frac{1}{h}}, \tag{5.4}$$

and we assume the inequalities are valid for all $0 < h < 1/2$. Using these inequalities it is easy to show that the function $E(t) = e^t$ has the property that $E'(0) = 1$.

We write, for $0 < h < 1/2$,

$$(1 + h)^{\frac{1}{h}} < e < \left(1 + \frac{h}{1 - h}\right)^{\frac{1}{h}}$$

$$1 + h < e^h < 1 + \frac{h}{1 - h}$$

$$h < e^h - 1 < \frac{h}{1 - h}$$

$$1 < \frac{e^h - 1}{h} < \frac{1}{1 - h}$$

As $h \rightarrow 0$ ↓ ↓ ↓

$$1 \leq E'(0) \leq 1$$

Thus for $E(t) = e^t$, $E'(0) = 1$.

Because of Theorem 5.1.1, $E'(t) = E'(0) \times E(t) = e^t$, we have another Primary Formula for computing derivatives:

$$[e^t]' = e^t \quad \text{Exponential Rule} \quad (5.5)$$

Strategy for computing derivatives: Now we can use three Primary Formulas (Constant, Power, Exponential) and three Composition Formulas (Sum, Constant Factor, Power Chain) to compute derivatives. In finding derivatives of functions with many terms, students sometimes ask what derivative rule to use first and in subsequent steps. We think of the derivative procedure as peeling the layers off of an onion – outside layer first, etc. For example, to compute the derivative of $F(t) = (2 + 3t^2 + 5e^t)^3$ we write:

$F'(t) = [(2 + 3t^2 + 5e^t)^3]'$	Symbolic Identity	}	(5.6)
$= 3(2 + 3t^2 + 5e^t)^2 [2 + 3t^2 + 5e^t]'$	Power Chain Rule		
$= 3(2 + 3t^2 + 5e^t)^2 ([2]' + [3t^2]' + [5e^t]')$	Sum Rule		
$= 3(2 + 3t^2 + 5e^t)^2 (0 + [3t^2]' + [5e^t]')$	Constant Rule		
$= 3(2 + 3t^2 + 5e^t)^2 (3[t^2]' + 5[e^t]')$	Constant Factor Rule		
$= 3(2 + 3t^2 + 5e^t)^2 (3(2t) + 5[e^t]')$	Power Rule		
$= 3(2 + 3t^2 + 5e^t)^2 (6t + 5e^t)$	Exponential Rule		

Think how the expression for F in the previous example, $F(t) = (2 + 3t^2 + 5e^t)^3$, is evaluated. Given a value for t you would compute t^2 and multiply it by 3 and you would compute e^t and multiply it by 5, and then you would sum the three terms. The *last step* (outside layer) in the evaluation is to cube the sum. The *first step* in computing the derivative is to ‘undo’ that cube (use the Power Chain Rule).

The next step is to undo the sum with the Sum Rule. The next step is not uniquely determined; we worked from left to right and chose to evaluate $[2]'$.

In evaluating $3t^2$ and $5e^t$, the last step would be to multiply by 3 or 5 – the first step in finding the derivative of $3t^2$ and $5e^t$ is to factor 3 and 5 from the derivative (Constant Factor Rule),

$$[3t^2]' = 3 [t^2]' \qquad [5e^t]' = 5 [e^t]'$$

Finally the Primary Formulas for $[t^2]'$ and $[e^t]'$ are used.

Usual course of events.

In computing derivatives, use the Composition Formulas first and the Primary Formulas last.

5.2.1 Proof that $\lim_{h \rightarrow 0} (1+h)^{1/h}$ exists.

Our goal is to prove that

$$\lim_{h \rightarrow 0} (1+h)^{1/h} \quad \text{exists.}$$

We only consider the values of h for $h = \frac{1}{n}$ where n a positive integer, however, and show that

$$\lim_{n \rightarrow \infty} \left(1 + \frac{1}{n}\right)^n \quad \text{exists.}$$

You may accept this information without proof and proceed to the section exercises. The material of this subsection is very important, however, and deserves your substantial independent effort.

Explore 5.2.3 Do this! Explain the MATLAB program and the graph it creates and their relevance to our goal. ■

```
close all;clc;clear
h=[0.01:0.01:1];
y=(1+h).^(1./h);
plot(h,y,'k','linewidth',2)
hold('on')
For n = 1:8
z=(1+1/n)^n;
plot(1/n,z,'ks','linewidth',2)
end
axis([0 1.1 1.8 3])
```

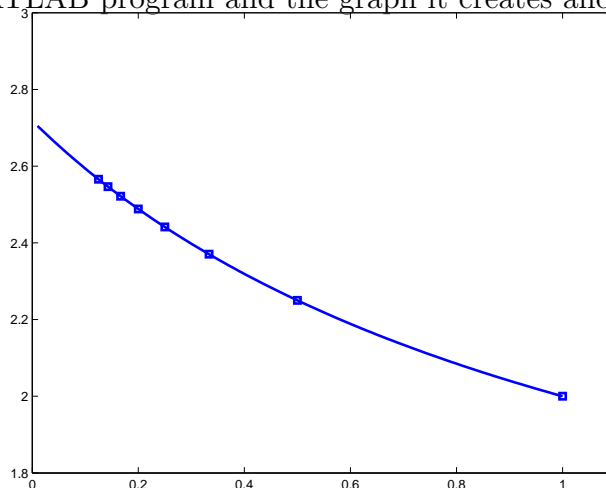

The graph in Explore 5.2.3 may convince you that $\lim_{h \rightarrow 0} (1+h)^{1/h}$ exists and that there is nothing left to prove. But it is the existence of a number that is the limit that is in question and that existence requires a crucial property of the number system called *completeness*.

Axiom 5.2.1 Completeness property of the number system. *If S_1 and S_2 are two sets of numbers and*

1. *Every number belongs to either S_1 or S_2 , and*
2. *Every number of S_1 is less than every number of S_2 ,*

then there is a number C such that C is either the largest number of S_1 or C is the least number of S_2 .

The statement of the Completeness Axiom by Richard Dedekind in 1872 greatly increased our understanding of the number system. In this text, the word 'set' means a nonempty set.

As noted above, we only consider values of $h = 1/n$ where n is a positive integer and we define

$$s_n = \left(1 + \frac{1}{n}\right)^n \quad \text{and prove that} \quad \lim_{n \rightarrow \infty} s_n \quad \text{exists.}$$

That a sequence of numbers $s_1, s_2, s_3 \dots$ is bounded means that an open interval (A, B) ¹ contains every number in $s_1, s_2, s_3 \dots$; A is called a lower bound and B is called an upper bound of $s_1, s_2, s_3 \dots$.

The sequence $\{1, 4, 9, 16, 25, \dots\}$ has no upper bound and is not bounded. The sequence $\{1, \frac{1}{2}, \frac{1}{3}, \frac{1}{4}, \dots\}$ is bounded by the numbers 0 and 2. The sequence $\{1, -2, 3, -4, 5, -6, \dots\}$ has neither a lower bound nor an upper bound and is not bounded.

For this section we prove:

Theorem 5.2.1 *If $s_1 \leq s_2 \leq s_3 \leq \dots$ is a bounded nondecreasing sequence of numbers there is a number s such that $\lim_{n \rightarrow \infty} s_n = s$.*

To prove Theorem 5.2.1 we need a clear definition of limit of a sequence.

Definition 5.2.2 *A number s is the limit of a number sequence $s_1, s_2, s_3 \dots$ means that if (u, v) is an open interval containing s there is a positive integer N such that if n is an integer greater than N , s_n is in (u, v) . It is sometimes said that $s_1, s_2, s_3 \dots$ converges to s or approaches s .*

Example 5.2.1 The limit of the sequence $\{1, \frac{1}{2}, \frac{1}{3}, \frac{1}{4}, \dots\}$ is zero. If (u, v) contains 0, v is greater than zero and there is² a positive integer N that is greater than $1/v$. Therefore, if $n > N$, $n > 1/v$ so that $1/n < v$, and $u < 0 < 1/n < v$, so $\frac{1}{n}$ is in (u, v) . ■

Proof of Theorem 5.2.1. Suppose $s_1, s_2, s_3 \dots$ is a nondecreasing sequence bounded by A and B . Let S_1 be the set of numbers x for which some number of $s_1, s_2, s_3 \dots$ is greater than x . A is a member of S_1 and B is not a member of S_1 . Let S_2 denote all of the numbers not in S_1 . Clearly every number is in either S_1 or S_2 .

¹If A and B are numbers with $A < B$, the open interval (A, B) consists of all the numbers between A and B ; the closed interval $[A, B]$ consists of A , B , and all of the numbers between A and B .

²This is called the Archimedean property of the integers and may be treated as an axiom also. It is, however, a consequence of the Completeness Axiom, Exercise 5.2.11

To use the Completeness Axiom we must show that every number of S_1 is less than every number of S_2 . Suppose not; suppose there is a number x of S_1 that is greater than a number y of S_2 . Then x has the property that some number, s_n , say of $s_1, s_2, s_3 \dots$ is greater than x and y is not in S_1 so no number of $s_1, s_2, s_3 \dots$ is greater than y . However, the supposition that $y < x$ and $x < s_n$, leads to $y < s_n$ which is a contradiction. Therefore every number of S_1 is less than every number of S_2 .

By the Completeness Axiom, either S_1 has a largest number or S_2 has a least number. Suppose S_1 has a largest number, L_1 . By definition of S_1 there is a member s_n of $s_1, s_2, s_3 \dots$ greater than L_1 . Now $\frac{L_1 + s_n}{2}$ is less than s_n so $\frac{L_1 + s_n}{2}$ is in L_1 . But $\frac{L_1 + s_n}{2}$ is greater than L_1 so L_1 is not the largest member of S_1 , which is a contradiction; S_1 does not have a largest number. Therefore S_2 must have a least number, L_2 .

We prove that $s_1, s_2, s_3 \dots$ approaches L_2 . Suppose (u, v) is an open interval containing L_2 . Then u is less than L_2 so belongs to S_1 and there is a number, s_N in $s_1, s_2, s_3 \dots$ that is greater than u . Because $s_1, s_2, s_3 \dots$ is increasing, if n is greater than N , $s_N \leq s_n$. No number of $s_1, s_2, s_3 \dots$ is greater than L_2 . Therefore if n is greater than N ,

$$u < s_N \leq s_n < L_2 < v$$

and the definition that $s_1, s_2, s_3 \dots$ approaches L_2 is satisfied.

End of proof.

Example 5.2.2 We can use Theorem 5.2.1 to show a useful result, that if a is a number and $0 < a < 1$, then the sequence $x_n = a^n$ converges to zero.

Proof. We assume the alternate version of Theorem 5.2.1 that if $s_1 \geq s_2 \geq s_3 \geq \dots$ is a bounded nonincreasing sequence of numbers there is a number s such that $\lim_{n \rightarrow \infty} s_n = s$.

Because $0 < a < 1$ and $x_n = a^n$, $x_{n+1} = a \cdot x_n$ and $x_{n+1} < x_n$, and it follows that x_n is a nonincreasing (actually decreasing) sequence. Then $\{x_n\}$ approaches the greatest lower bound, s of $\{x_n\}$.

If $s < 0$, then $(2s, 0)$ is an open interval containing s and there is a number, x_m in $\{x_n\}$ in $(2s, 0)$. Then $x_m = a^m$ is negative which is a contradiction.

Suppose $s > 0$. Because $0 < a < 1$, the number s/a is greater than s and there is a number, x_m in $\{x_n\}$ such that $x_m < s/a$. Because s is a lower bound on $\{x_n\}$, $s \leq x_m$. Then

$$s \leq x_m < s/a, \quad s \leq a^m < s/a, \quad s \cdot a < a^{m+1} < s, \quad x_{m+1} < s.$$

But this contradicts the condition that s is a lower bound on $\{x_n\}$.

We conclude that s , the greatest lower bound on $\{x_n\}$, is zero and $\{x_n\}$ converges to 0. ■

Now to the number, e . We are to show that $\lim_{n \rightarrow \infty} (1 + \frac{1}{n})^n$ exists. We will show that

1. The sequence $s_n = (1 + \frac{1}{n})^n$ is an increasing sequence.
2. The sequence $t_n = (1 + \frac{1}{n-1})^n$, $n > 1$, is a decreasing sequence.
3. For every $n > 1$, $s_n < t_n$.
4. As n increases without bound, $t_n - s_n$ approaches 0.

Conditions 1 and 3 show that $s_1 < s_2 < s_3 < \dots$ is a bounded increasing sequence and therefore approaches a number s . That number s is the number we denote by e . Conditions 2 and 3 show that $t_1 > t_2 > t_3 > \dots$ is a bounded decreasing sequence and it follows from Theorem 5.2.1³ that

³Observe that $-t_1 < -t_2 < -t_3 < \dots$ is a bounded increasing sequence and there is a number $-t$ such that $-t_1 < -t_2 < -t_3 < \dots$ approaches $-t$.

there is a number t such that $t_1 > t_2 > t_3 > \dots$ converges to t . By condition 4 above, $t = s$.

The proofs of conditions 3 and 4 above are left as exercises. Our argument for conditions 1 and 2 is that of N. S. Mendelsohn⁴ based on the following theorem. The theorem is of general interest and we prove it in Subsection 8.1.2, independently of the work in this section.

Theorem 5.2.2 *If a_1, a_2, \dots, a_n is a sequence of n positive numbers then*

$$\frac{a_1 + a_2 + \dots + a_n}{n} \geq \sqrt[n]{a_1 a_2 \dots a_n} \quad (5.7)$$

with equality only when $a_1 = a_2 = \dots = a_n$.

The left side of inequality 5.7 is the *arithmetic mean* and the right side is the *geometric mean* of a_1, a_2, \dots, a_n . The theorem states that the arithmetic mean is greater than or equal to the geometric mean.

1. *Proof that $(1 + \frac{1}{n})^n$ is increasing.* Consider the set of $n + 1$ numbers

$$1, \quad 1 + \frac{1}{n}, \quad 1 + \frac{1}{n} \quad \dots \quad 1 + \frac{1}{n}$$

They are not all equal and they have an arithmetic mean of $1 + 1/(n + 1)$ and a geometric mean of $(1 \times (1 + 1/n)^n)^{1/(n+1)}$. Then

$$1 + \frac{1}{n+1} > ((1 + 1/n)^n)^{1/(n+1)} \quad \text{or} \quad \left(1 + \frac{1}{n+1}\right)^{n+1} > (1 + 1/n)^n$$

Hence $s_{n+1} > s_n$ and the sequence s_1, s_2, \dots is increasing.

2. *Proof that $(1 + \frac{1}{n-1})^n$ is decreasing.* Consider the set of $n + 1$ numbers

$$1, \quad \frac{n-1}{n}, \quad \frac{n-1}{n} \quad \dots \quad \frac{n-1}{n}$$

They have an arithmetic mean of $n/(n + 1)$ and a geometric mean of $(1 \times ((n - 1)/n)^n)^{1/(n+1)}$ and

$$\frac{n}{n+1} > \left(\frac{n-1}{n}\right)^{n/(n+1)}$$

By taking reciprocals this becomes

$$\frac{n+1}{n} < \left(\frac{n}{n-1}\right)^{n/(n+1)} \quad \text{or} \quad \left(1 + \frac{1}{(n+1)-1}\right)^{n+1} < \left(1 + \frac{1}{n-1}\right)^n$$

It follows that $t_{n+1} < t_n$ and t_1, t_2, \dots is decreasing. *End of proof.*

We have shown that $\lim_{n \rightarrow \infty} (1 + \frac{1}{n})^n = e$. We claim the more general result that

$\lim_{h \rightarrow 0} (1 + h)^{1/h} = e$. We are encouraged to this claim by an identification of $h = 1/n$, but there are other values of h to consider that are not reciprocals of integers. You will show in Exercise 12.2.5 that the slope of the graph in Explore 5.2.3 is negative and this provides a way to complete the proof that $\lim_{h \rightarrow 0} (1 + h)^{1/h} = e$. In the suggested solution to that exercise, $[\ln u(x)]'$ is used.

$\log_{10} u(x)$ could be used equally well, so that the argument is not dependent on the number e .

⁴American Mathematical Monthly, **58** (1951) p. 563.

Explore 5.2.4 Explain the MATLAB program and the graph it creates and their relevance to the previous paragraph. ■

```
close all;clc;clear
h=[0.01:0.01:1];
N=[10, 11, 13,17,20,25,33,50,100];
F=0*h;
for i = 1:9
    F(N(i))=1;
end
plot(h,F,'kd','linewidth',2)
axis([0 1.1 -0.1 1.1])
```

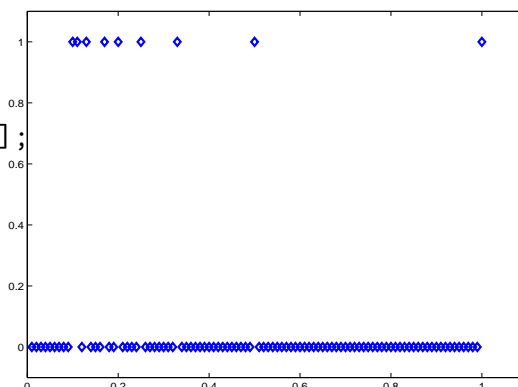

Exercises for Section 5.2, The number e.

Exercise 5.2.1 Derivatives of functions are computed below. Identify the rule used in each step. In a few steps the rule is an algebraic rule of exponents and not a derivative rule.

a. $[5t^4 - 7e^t]'$	b. $[(1 + e^t)^8]'$	c. $[e^{3t}]'$
$[5t^4]' - [7e^t]'$	$8(1 + e^t)^7 [1 + e^t]'$	$[(e^t)^3]'$
$5[t^4]' - 7[e^t]'$	$8(1 + e^t)^7 ([1]' + [e^t]')$	$3(e^t)^2 [e^t]'$
$5 \times 4t^3 - 7[e^t]'$	$8(1 + e^t)^7 (0 + [e^t]')$	$3(e^t)^2 \times e^t$
$5 \times 4t^3 - 7 \times e^t$	$8(1 + e^t)^7 (0 + e^t)$	$3e^{2t} \times e^t$
	$8e^t (1 + e^t)^7$	$3e^{3t}$

Exercise 5.2.2 Differentiate (means compute the derivative of) P . Use one rule for each step and identify the rule as, C (Constant Rule), t^n (t^n Rule), S (Sum Rule), CF (Constant Factor Rule), PC (Power Chain Rule), or E (Exponential Rule). For example,

$[\pi t^{-2} - 5(e^t)^7]'$	$= [\pi t^{-2}]' - [5(e^t)^7]'$	S
	$= \pi [t^{-2}]' - 5 [(e^t)^7]'$	CF
	$= \pi \times (-2)t^{-3} - 5 [(e^t)^7]'$	t^n
	$= -2\pi t^{-3} - 5(7)(e^t)^6 [e^t]'$	PC
	$= -2\pi t^{-3} - 35(e^t)^6 \times e^t$	E
	$= -2\pi t^{-3} - 35(e^t)^7$	Algebra

$$\begin{array}{ll}
 \text{a. } P(t) = 5t^2 + 32e^t & \text{b. } P(t) = 3(e^t)^5 - 6t^5 \\
 \text{c. } P(t) = 7 - 8(e^t)^{-1} & \text{d. } P(t) = \frac{2}{5} + \frac{t}{3} \\
 \text{e. } P(t) = t^{25} + 3e & \text{f. } P(t) = \frac{4}{e} + \frac{t^5}{7} \\
 \text{g. } P(t) = 1 + t + \frac{t^2}{2} - e^t & \text{h. } P(t) = \frac{(e^t)^2}{2} + \frac{t^3}{3}
 \end{array}$$

Careful, the next two are easier than you might first think.

$$\text{i. } P(t) = 5e^3 \qquad \text{j. } P(t) = 10 \times \pi^2$$

Exercise 5.2.3 Draw the graphs of

$$y_1(t) = e^t \qquad y_2(t) = t^2 \qquad y_3(t) = t^3 \qquad y_4(t) = t^4 \qquad -1 \leq t \leq 5$$

The graphs are close together near $t = 0$ and increase as t increases. Which one grows the most as t increases? Expand the domain and range to $-1 \leq t \leq 10$, $0 \leq y \leq 25,000$, and answer the same question.

Exercise 5.2.4 Draw the graphs of

$$y(t) = e^t \qquad \text{and} \qquad p(t) = 1 + t + \frac{t^2}{2} + \frac{t^3}{6} + \frac{t^4}{24}$$

Set the domain and range to $-1 \leq t \leq 2$. and $0 \leq y \leq 8$.

Exercise 5.2.5 We found a base e so that $E(t) = e^t$ has the property that the rate of change of E at 0 is 1. Suppose we had searched for a number B so that the *average* rate of change of $E_B(t) = B^t$ on $[0, 0.01]$ is 1:

$$m_{0,0.01} = \frac{E_B(0.01) - E_B(0)}{0.01} = \frac{B^{0.01} - B^0}{0.01} = \frac{B^{0.01} - 1}{0.01} = 1.$$

- Solve the last equation for B .
- Solve for B in each of the equations:

$$\frac{B^{0.001} - 1}{0.001} = 1 \qquad \frac{B^{0.00001} - 1}{0.00001} = 1 \qquad \frac{B^{0.0000001} - 1}{0.0000001} = 1$$

Exercise 5.2.6 On a popular television business news channel, an analyst exclaimed that "XXX stock has gone parabolic." Is there some sense in which this exclamation is more exuberant than "XXX stock has gone exponential?"

Exercise 5.2.7 Let $y(x) = e^x$. Compute $y'(x)$, $y''(x) = (y')'$, and $y'''(x)$.

Exercise 5.2.8 We introduced the power chain rule $[(u(x))^n]' = n(u(x))^{n-1}[u(x)]'$ for fractional and negative exponents, n , in Section 4.3.1 (see Exercises 4.3.3 and 4.3.4). Use these rules when necessary in the following exercise.

Compute $y'(x)$ and $y''(x)$ for

a. $y(x) = x^2 + e^x$	b. $y(x) = 3x^2 + 2e^x$
c. $y(x) = (1 + e^x)^2$	d. $y(x) = (e^x)^2$
e. $y(x) = e^{2x} = (e^x)^2$	f. $y(x) = e^{-x} = (e^x)^{-1}$
g. $y(x) = e^{3x} = (e^x)^3$	h. $y(x) = e^x \times e^{2x}$
i. $y(x) = (5 + e^x)^3$	j. $y(x) = \frac{1}{1+e^x} = (1 + e^x)^{-1}$
k. $y(x) = \sqrt{e^x} = (e^x)^{\frac{1}{2}}$	l. $y(x) = e^{\frac{1}{2}x}$
m. $y(x) = e^{0.6x} = (e^x)^{0.6}$	n. $y(x) = e^{-0.005x}$

Exercise 5.2.9 Identify the errors in the following derivative computations.

a. $[(t^4 + t^{-1})^7]'$	b. $[5t^7 + 7t^{-5}]'$	c. $[10t^8 + 8e^{5t}]'$
$7(t^4 + t^{-1})^6 [t^4 + t^{-1}]'$	$[5t^7]' + [7t^{-5}]'$	$[10t^8]' + [8e^{5t}]'$
$7(t^4 + t^{-1})^6 [t^4]' + [t^{-1}]'$	$5[t^7]' + 7[t^{-5}]'$	$10[t^8]' + 8[e^{5t}]'$
$7(t^4 + t^{-1})^6 4t^3 + (-1)t^{-2}$	$5 \times 7t^6 + 7 \times (-5)t^{-4}$	$10 \times 8t^7 + 8 \times 5e^{4t}$
$28t^3(t^4 + t^{-1})^6 - t^{-2}$	$35(t^6 - t^{-4})$	$40(2t^7 + e^{4t})$

Exercise 5.2.10 Locate the point $(0, e)$ on the graph in Explore 5.2.3

Exercise 5.2.11 Use the Completeness Axiom 5.2.1 to show that the positive integers do not have an upper bound. (This is called the Archimedean Axiom).

Exercise 5.2.12 Argue that if S_1 and S_2 are two sets of numbers and every number is in either S_1 or S_2 and every number in S_1 is less than every number in S_2 then it is not true that there are numbers L_1 and L_2 such that L_1 is the greatest number in S_1 and L_2 is the least number in S_2 . Is this a contradiction to the Completeness Axiom?

Exercise 5.2.13 Let S_2 denote the points of the X -axis that have positive x -coordinate and S_1 denote the points of the X -axis that do not belong to S_2 . Does S_2 have a left most point?

Exercise 5.2.14 Suppose S_2 is the set of numbers to which x belongs if and only if x is positive and $x^2 > 2$ and S_1 consists of all of the other numbers.

1. Give an example of a number in S_2 .

2. Give an example of a number in S_1 .
3. Argue that every number in S_1 is less than every number in S_2 .
4. Which of the following two statements is true?
 - (a) There is a number C which is the largest number in S_1 .
 - (b) There is a number C which is the least number in S_2 .
5. Identify the number C in the correct statement of the previous part.

Exercise 5.2.15 Suppose your number system is that of Early Greek mathematicians and includes only rational numbers. Does it satisfy the Axiom of Completion?

Exercise 5.2.16 Show that if $n \geq 2$ and $s_n = \left(1 + \frac{1}{n}\right)^n$ and $t_n = \left(1 + \frac{1}{n-1}\right)^n$ then

- a. For every n $s_n < t_n$.
- b. Justify the steps (i) to (iv) in

$$t_n - s_n = \left(1 + \frac{1}{n-1}\right)^n - \left(1 + \frac{1}{n}\right)^n \quad (i)$$

$$= \left[\left(1 + \frac{1}{n-1}\right) - \left(1 + \frac{1}{n}\right) \right] \times \left[\left(1 + \frac{1}{n-1}\right)^{n-1} + \left(1 + \frac{1}{n-1}\right)^{n-2} \left(1 + \frac{1}{n}\right) + \cdots + \left(1 + \frac{1}{n-1}\right) \left(1 + \frac{1}{n}\right)^{n-2} + \left(1 + \frac{1}{n}\right)^{n-1} \right] \quad (ii)$$

$$= \leq \frac{1}{n(n-1)} \times n \times \left(1 + \frac{1}{n-1}\right)^{n-1} \quad (iii)$$

$$= \leq \frac{1}{n-1} \times 4 \quad (iv)$$

- c. As n increases without bound, $t_n - s_n$ approaches zero.

5.3 The natural logarithm

The *natural* logarithm function, \ln , is defined for $u > 0$ by

$$\lambda = \ln u = \log_e u \iff u = e^\lambda \quad (5.8)$$

The natural logarithm is the logarithm to the base e and the properties of logarithms for all bases apply:

$$\ln(A \times B) = \ln(A) + \ln(B) \quad (5.9)$$

$$\ln(A/B) = \ln(A) - \ln(B) \quad (5.10)$$

$$\ln(A^c) = c \times \ln(A) \quad (5.11)$$

$$\text{If } d > 0, d \neq 1, \text{ then } \log_d A = \frac{\ln A}{\ln d} \quad (5.12)$$

$$u = e^{\ln u} \quad (5.13)$$

$$\ln(e^\lambda) = \lambda \quad (5.14)$$

The natural logarithm is keyed on most calculators as \ln or LN . Equation 5.12 shows that all logarithms may be calculated using just the natural logarithm. However, \log_{10} is also keyed on most calculators and the key may be labeled Log or LOG . But in MATLAB $\log(x)$ means natural logarithm of x .

Using Equation 5.13 we can express all exponential functions in terms of the base e . To see this, suppose $B > 0$ and $E(t) = B^t$. Equation 5.13 states that

$$B = e^{\ln B}$$

so we may write $E(t) = B^t$ as

$$E(t) = B^t = (e^{\ln B})^t = e^{t \ln B}$$

For example, $\ln 2 \doteq 0.631472$. For $E(t) = 2^t$ we have

$$E(t) = 2^t = (e^{\ln 2})^t = e^{t \ln 2} \doteq e^{0.631472 t}$$

As a consequence, functions of the form $E(t) = e^{kt}$, k a constant, are very important and we compute their derivative in the next section.

Example 5.3.1 We found in Chapter 1 that cell density (measured by light absorbance, Abs) of *Vibrio natriegens* growing in a flask at pH 6.25, data in Table 1.1, was described by (Equation 1.5)

$$\text{Abs} = 0.0174 \times 1.032^{\text{Time}}$$

Using natural logarithm, we write this in terms of e as

$$\text{Abs} = 0.0174 \times 1.032^{\text{Time}}$$

$$\text{Abs} = 0.0174 [e^{\ln 1.032}]^{\text{Time}} \quad \text{Equation 5.13}$$

$$\text{Abs} = 0.0174 [e^{0.03150}]^{\text{Time}} \quad \ln 1.022 \doteq 0.02176$$

$$\text{Abs} = 0.0174 e^{0.03150 \times \text{Time}} \quad \text{Equation 5.11. } \blacksquare$$

Exercises for Section 5.3, The natural logarithm.

Exercise 5.3.1 You should have found in Explore 1.6.1 that plasma penicillin during 20 minutes following injection of two grams of penicillin could be computed as

$$P(T) = 200 \times 0.77^T \quad T = \text{index of five minute intervals.}$$

- Write P in the form of $P(T) = 200 e^{-k_1 T}$.
- Write P in the form of $P(t) = 200 e^{-k_2 t}$ where t measures time in minutes.

Exercise 5.3.2 Use Equation 5.12, $\log_d A = \ln A / \ln d$ to compute $\log_2 A$ for $A = 1, 2, 3, \dots, 10$.

Exercise 5.3.3 We found in Section 1.3 that light intensity, I_d , as a function of depth, d was given by

$$I_d = 0.4 \times 0.82^d$$

Find k so that $I_d = 0.4e^{k \times d}$.

Exercise 5.3.4 Write each of the following functions in the form $f(t) = A e^{kt}$.

- $f(t) = 5 \cdot 10^t$
- $f(t) = 5 \cdot 10^{-t}$
- $f(t) = 7 \cdot 2^t$
- $f(t) = 5 \cdot 2^{-t}$
- $f(t) = 5 \left(\frac{1}{2}\right)^t$
- $f(t) = 5 \left(\frac{1}{2}\right)^{-t}$

Exercise 5.3.5 Use the Properties of Logarithms, Equations 5.9 - 5.14 to write each of the following functions in the form $f(t) = A + B \ln t$.

- $f(t) = 5 \log_{10} t$
- $f(t) = 5 \log_2 t^3$
- $f(t) = 7 \log_5 5t$
- $f(t) = 5 \log_{10} 3t$
- $f(t) = 3 \log_4(t/2^3)$
- $f(t) = 3 \log_8(16t^{10})$

5.4 The derivative of e^{kt} .

We have found the derivative of e^t . Often, however, the function of interest is of the form $C e^{kt}$ where C and k are constants. In Example 5.3.1 of bacterial growth,

$$\text{Abs} = 0.0174 e^{0.02176 \text{ Time}}$$

the constant $C = 0.0174$ and the function $kt = 0.02176 \text{ Time}$. We develop a formula for $[e^{kt}]'$.

$$\begin{aligned} [e^{kt}]' &= [(e^t)^k]' && (i) \\ &= k (e^t)^{k-1} [e^t]' && (ii) \\ &= k (e^t)^{k-1} e^t && (iii) \\ &= k e^{kt}. \end{aligned} \tag{5.15}$$

Because Equation 5.15 $[e^{kt}]' = k e^{kt}$, is used so often, we call it another Primary Formula even though we developed it without direct reference to the Definition of Derivative. **Should you be limited to a single derivative rule, in the life sciences choose the e^{kt} Rule** – exponential functions are ubiquitous in biology.

e^{kt} Rule

$$E(t) = e^{kt} \Rightarrow E'(t) = e^{kt} k \quad [e^{kt}]' = k e^{kt} \quad (5.16)$$

Explore 5.4.1 Were we to derive $[e^{kt}]' = k e^{kt}$ from the Definition of Derivative, we would write:

$$\begin{aligned} [e^{kt}]' &= \lim_{b \rightarrow a} \frac{e^{kb} - e^{ka}}{b - a} && (i) \\ &= \lim_{b \rightarrow a} \frac{e^{kb} - e^{ka}}{kb - ka} k && (ii) \\ &= e^{ka} k && (iii) \end{aligned} \quad (5.17)$$

The assertion in step (iii) that

$$\lim_{b \rightarrow a} \frac{e^{kb} - e^{ka}}{kb - ka} = e^{ka}$$

is correct, puzzles some students, and is worth your thought. ■

We can now differentiate functions like $P(t) = 5t^7 + 3e^{2t}$.

$$\begin{aligned} P'(t) &= [5t^7 + 3e^{2t}]' && \text{A symbolic identity.} \\ &= [5t^7]' + [3e^{2t}]' && \text{Sum Rule} \\ &= 5[t^7]' + 3[e^{2t}]' && \text{Constant Factor Rule} \\ &= 5 \times 7t^6 + 3[e^{2t}]' && \text{Power Rule} \\ &= 35t^6 + 3e^{2t} \cdot 2 && e^{kt} \text{ Rule} \\ &= 35t^6 + 6e^{2t} \end{aligned}$$

Example 5.4.1 We can also compute $E'(t)$ for $E(t) = 2^t$.

$$[2^t]' = \left[(e^{\ln 2})^t \right]' = [e^{(\ln 2)t}]' = e^{(\ln 2)t} \ln 2 = 2^t \ln 2$$

We have an exact solution for the first problem of this Chapter, which was to find $E'(2)$ for $E(t) = 2^t$. The answer is $2^2 \ln 2 = 4 \ln 2$. Also, $E'(0) = 2^0 \ln 2 = \ln 2$ which answers another question from early in the chapter. ■

More generally, for $b > 0$,

$$\begin{aligned}
 [b^t]' &= \left[(e^{\ln b})^t \right]' && (i) \\
 &= \left[e^{(\ln b)t} \right]' && (ii) \\
 &= e^{(\ln b)t} \ln b && (iii) \\
 &= b^t \ln b && (iv)
 \end{aligned} \tag{5.18}$$

We summarize this information:

$$[b^t]' = b^t \ln b \quad \text{for } b > 0. \tag{5.19}$$

Explore 5.4.2 This is very important. Show that if C and k are constants and $P(t) = Ce^{kt}$ then $P'(t) = kP(t)$. ■

Exercises for Section 5.4, The derivative of e^{kt} .

Exercise 5.4.1 Give reasons for the steps (i) – (iii) in Equation 5.15 showing that $[e^{kt}]' = e^{kt} k$.

Exercise 5.4.2 Give reasons for the steps (i) – (iv) in Equation 5.18 showing that $[b^t]' = b^t \ln b$.

Exercise 5.4.3 The function b^t for $b = 1$ is a special exponential function. Confirm that the derivative equation $[b^t]' = b^t \ln b$ is valid for $b = 1$. Draw some graphs of b^t for $b = 1$ and its derivative.

Exercise 5.4.4 Use one rule for each step and identify the rule to differentiate

$$\begin{array}{ll}
 \text{a. } P(t) = 3e^{5t} + \pi & \text{b. } P(t) = \frac{e^2}{2} + \frac{t^3}{3} \\
 \text{c. } P(t) = 5^t & \text{d. } P(t) = e^{2t} e^{3t}
 \end{array}$$

Simplify Part d before differentiating.

Exercise 5.4.5 Compute $y'(x)$ or assert that you do not yet have formulas to compute $y'(x)$ for

- | | |
|--------------------------------------|---|
| a. $y(x) = e^{5x}$ | b. $y(x) = e^{-3x}$ |
| c. $y(x) = e^{\sqrt{x}}$ | d. $y(x) = (e^x)^2$ |
| e. $y(x) = (e^{\sqrt{x}})^2$ | f. $y(x) = (e^{-x})^2$ |
| g. $y(x) = \frac{e^x + e^{-x}}{2}$ | h. $y(x) = \frac{e^x - e^{-x}}{2}$ |
| i. $y(x) = 5e^{-0.06x} + 3e^{-0.1x}$ | j. $y(x) = e^{(x^2)}$ |
| k. $y(x) = \sqrt{e^x}$ | l. $y(x) = 8e^{-0.0001x} - 16e^{-0.001x}$ |
| m. $y(x) = e^5$ | n. $y(x) = \sqrt{e}$ |
| o. $y(x) = 10^x$ | p. $y(x) = 10^{-x}$ |
| q. $y(x) = x^2 + 2^x$ | r. $y(x) = (e^{5x} + e^{-3x})^5$ |

Exercise 5.4.6 Interpret e^{t^2} as $e^{(t^2)}$. Argue that

$$\lim_{b \rightarrow a} \frac{e^{(b^2)} - e^{(a^2)}}{b^2 - a^2} = e^{(a^2)}$$

What is the ambiguity in the notation e^{a^2} . (Consider 4^{3^2} .) **Use parenthesis, they are cheap.** However, common practice is to interpret e^{t^2} as $e^{(t^2)}$.

Exercise 5.4.7 Argue that

$$\lim_{b \rightarrow a} \frac{e^{\sqrt{b}} - e^{\sqrt{a}}}{\sqrt{b} - \sqrt{a}} = e^{\sqrt{a}}$$

Exercise 5.4.8 Review the method in Explore 5.4.1 and the results in Exercises 5.4.6 and 5.4.7. Use Definition 3.22,

$$F'(a) = \lim_{b \rightarrow a} \frac{F(b) - F(a)}{b - a}, \quad \text{to compute } E'(a) \text{ for}$$

- | | | |
|--------------------|-----------------------------|----------------------|
| a. $E(t) = e^{2t}$ | b. $E(t) = e^{2\sqrt{t}}$ | c. $E(t) = e^{-t}$ |
| d. $E(t) = e^2$ | e. $E(t) = e^{\frac{1}{t}}$ | f. $E(t) = e^{-t^2}$ |

Exercise 5.4.9 Consider the kinetics of penicillin that is taken as a pill in the stomach. The diagram in Figure Ex. 5.4.9(a) may help visualize the kinetics. We will find in Chapter 17 that a model of plasma concentration of antibiotic t hours after ingestion of an antibiotic pill yields an equation similar to

$$C(t) = 5e^{-2t} - 5e^{-3t} \quad \mu\text{g/ml} \quad (5.20)$$

A graph of C is shown in Figure Ex. 5.4.9. At what time will the concentration reach a maximum level, and what is the maximum concentration achieved?

As we saw in Section 3.5.2 and may be apparent from the graph in Figure Ex. 5.4.9, the highest concentration is associated with the point of the graph of C at which $C' = 0$; the tangent at the high point is horizontal. The question, then, is at what time t is $C'(t) = 0$ and what is $C(t)$ at that time?

Figure for Exercise 5.4.9 (a) Diagram of compartments for oral ingestion of penicillin. (b) Graph of $C(t) = 5e^{-2t} - 5e^{-3t}$ representative of plasma penicillin concentration t minutes after ingestion of the pill.

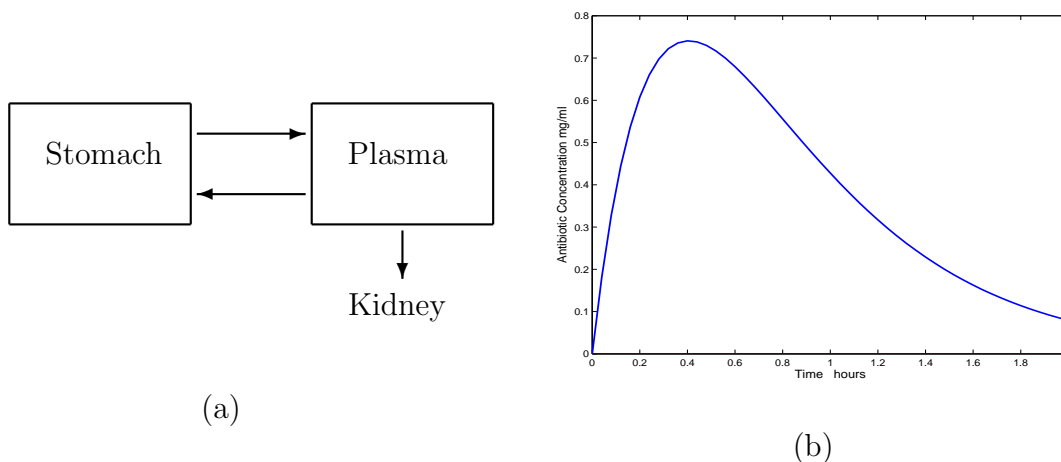

Exercise 5.4.10 Plasma penicillin concentration is

$$P(t) = 5 e^{-0.3t} - 5 e^{-0.4t}$$

t hours after ingestion of a penicillin pill into the stomach. A small amount of the drug diffuses into tissue and the tissue concentration, $C(t)$, is

$$C(t) = -e^{-0.3t} + 0.5e^{-0.4t} + 0.5e^{-0.2t} \quad \mu\text{g/ml}$$

- Use your technology (calculator or computer) to find the time at which the concentration of the drug in tissue is maximum and the value of C at that time.
- Compute $C'(t)$ and solve for t in $C'(t) = 0$. This is really bad, for you must solve for t in

$$0.3e^{-0.3t} - 0.2e^{-0.4t} - 0.1e^{-0.2t} = 0$$

Try this:

Let $Z = e^{-0.1t}$ then solve $0.3Z^3 - 0.2Z^4 - 0.1Z^2 = 0$.

- Solve for the possible values of Z . Remember that $Z = e^{-0.1t}$ and solve for t if possible using the possible values of Z .
- Which value of t solves our problem?

5.5 The derivative equation $P'(t) = k P(t)$

A crucial property of exponential functions established by the e^{kt} Rule is

Property 5.5.1 Proportional Growth or Decay. If P is a function defined by

$$P(t) = C e^{kt}$$

where C and k are numbers, then

$$P'(t) = k P(t)$$

Proof that $P(t) = C e^{kt}$ implies that $P'(t) = k P(t)$:

$$P'(t) = [C e^{kt}]' = C [e^{kt}]' = C e^{kt} k = k C e^{kt} = k P(t)$$

The reverse implication is also true, and is shown to be true in Chapter 17:

Property 5.5.2 Exponential Growth or Decay If P is a function and there is a number k for which

$$P'(t) = k P(t) \quad \text{for all } t \geq 0$$

then there is a number C for which

$$P(t) = C e^{kt}$$

Furthermore,

$$C = P(0) \quad \text{so that} \quad P(t) = P(0) e^{kt}$$

In the preceding equations, k can be either positive or negative. When k is negative, it is more common to emphasize this and write $-k$ and write $P(t) = e^{-kt}$, where in this context it is understood that k is a positive number.

In Chapter 1, we examined models of population growth, light decay, and penicillin clearance, all of which were of the form

$$P_{t+1} - P_t = R P_t$$

and found that

$$P_t = P_0 R^t$$

These are *discrete time* models in which the *average rate of change* of P_t is proportional to P_t . The exponential Growth or Decay Property 5.5.2 is simply a *continuous time* model in which the *rate*

of change of $P(t)$ is proportional to $P(t)$, and would be preferred in many instances. Bacterial populations may be visualized as growing continuously (and not in twenty minute bursts), the kidneys clear penicillin continuously (and not in five minute increments), and light decays continuously with depth (and not in one meter increments). Discrete time models are easy to comprehend and with short data intervals give good replications of data, but now that we know the definition of rate of change we can use continuous time or space models.

The equation

$$P' = kP \quad \text{or} \quad P'(t) = kP(t) \quad \text{or} \quad \frac{dP}{dt} = kP$$

derives from many models of biological and physical processes including population growth, drug clearance, chemical reaction, decay of radio activity – any system which can be described by:

Mathematical Model 5.5.1 Proportional change. The rate of change of a quantity is proportional to the amount of the quantity.

For example in population studies, we commonly assume that

Mathematical Model 5.5.2 Simple population growth. The growth rate of a population is proportional to the size of the population.

Let $P(t)$ be the size of a population at time, t . The component parts of the sentence in the Mathematical Model of simple population growth are symbolized by

- a: The growth rate of a population : $P'(t)$
- b: is proportional to : $= k \times$
- c: the size of the population : $P(t)$

The sentence of the Mathematical Model is then written

$$\underbrace{P'(t)}_a \quad = \underbrace{k \times}_b \quad \underbrace{P(t)}_c$$

From the property of Exponential Growth and Decay

$$P(t) = C \times e^{kt} \quad \text{and if } P(0) = P_0 \text{ is known} \quad P(t) = P_0 e^{kt} \tag{5.21}$$

In the event that the rate of **decrease** of a quantity, $P(t)$, is proportional to the size of $P(t)$, then because $-P'(t)$ is the rate of decrease of $P(t)$,

$$-P' = k P(t), \quad P' = -k P(t), \quad \text{and} \quad P(t) = P_0 e^{-kt},$$

where k is a positive number.

Example 5.5.1 A distinction between discrete and continuous models. Suppose in year 2000 a population is at 5 million people and the population growth rate (excess of births over deaths) is 6 percent per year. One interpretation of this is to let $P(t)$ be the population size in millions of people at time t measured in years after 2000 and to write

$$P(0) = 5 \quad P'(t) = 0.06 P(t)$$

Then, from the property of Exponential Growth or Decay 5.5.2, we may write

$$P(t) = P(0)e^{0.06t} = 5e^{0.06t}$$

$P(t) = 5e^{0.06t}$ does not exactly match the hypothesis that ‘population growth rate is 6 percent per year’, however. By this equation, after one year,

$$P(1) = 5e^{0.06 \times 1} = 5e^{0.06} \doteq 5 \times 1.0618$$

The consequence is that during the first year (and every year) there would be a 6.18 percent increase, a contradiction.

The discrepancy lies with the model equation $P'(t) = 0.6P(t)$. Instead, we may write

$$P(0) = 5 \quad P'(t) = kP(t)$$

where k is to be determined. Then from Exponential Growth or Decay 5.5.2 we may write

$$P(t) = 5e^{kt}$$

Now impose that $P(1) = 5 \times 1.06$, a 6 percent increase during the first year, and write

$$P(1) = 5e^{k \cdot 1} = 5 \times 1.06$$

This leads to

$$e^{k \times 1} = 1.06$$

We take the natural logarithm of both numbers and get

$$\begin{aligned} \ln(e^k) &= \ln 1.06 \\ k &= \ln 1.06 \\ &\doteq 0.05827 \end{aligned}$$

Then

$$P(t) = 5e^{0.05827t}$$

gives a description of the population t years after 2000. Each *annual* population is 6 percent greater than that of the preceding year. The continuous model of growth is actually

$$P(0) = 5 \quad P'(t) = (\ln 1.06)P(t) \quad P'(t) = 0.05827P(t)$$

Explore 5.5.1 Show that for the discrete equations

$$P_{t+1} - P_t = rP_t, \quad \text{with solution} \quad P_t = P_0(1+r)^t,$$

the solution to the continuous equation

$$p'(t) = (\ln(1+r))p(t), \quad p(0) = P_0$$

agrees with p_t at the integers. That is,

$$p(t) = P_t, \quad \text{for} \quad t = 0, 1, 2, \dots$$



Explore 5.5.2 Bacterial density for *v. natriegens* grown in a nutrient solution at pH of 6.75 was given in Section 1.1 and are reproduced below. It was found that $B_t = 0.022 (5/3)^t$ (Equation 1.4) matches the data very well. Find a number, k , such that the solution to $B(0) = 0.022$, $B'(t) = k B(t)$ matches the solution at integer values of t .

The variable t is used ambiguously here. In B_t , t is an index for 16-minute intervals and is 0, 1, 2, \dots , an integer. In $B(t)$, t is a number greater than or equal to zero, but is also measuring time in 16-minute intervals. For example, $B(2)$ is to be the bacterial density at the end of the second 16-minute interval, the same as B_2 . $B(1.5)$ is an estimate of the bacterial density at time 12 minutes, but $B_{1.5}$ is not defined.

Time (min)	0	16	32	48	64	80
Time index, t	0	1	2	3	4	5
<i>v. natriegens</i> density, B_t	0.022	0.036	0.060	0.101	0.169	0.266



The growth of a bank savings account is similar to this simplified model of population growth. If you deposited \$5000 in 2000 at a true 6 percent annual interest rate, it may amount to

$$P(t) = 5000e^{0.05827t}$$

dollars t years after 2000. On the other hand, some banks advertise and compute interest on the basis of 6% interest with 'instantaneous' compounding, meaning that their model is

$$P'(t) = 0.06 P(t)$$

leading to

$$P(t) = 5000e^{0.06t}$$

They will say that their 'APR' (annual percentage rate) is $100 e^{0.06} = 6.18$ percent.

The solution to the discrete system

$$P_0 \text{ known} \quad P_{n+1} = K P_n \quad \text{is} \quad P_n = P_0 K^n.$$

The solution of the continuous system

$$p(0) = P_0, \quad p'(t) = (\ln K) p(t) \quad \text{is} \quad p_t = P_0 e^{(\ln K)t} = P_0 K^t.$$

For $t = n$, an integer, $p(n) = P_n$.

Example 5.5.2 Geologists in the early nineteenth century worked out the sequential order of geological layers well before they knew the absolute dates of the layers. Their most extreme

estimates of the age of the earth was in the order of 400 million years⁵, about 1/10 of today's estimate of 4.54 ± 0.05 billion years⁶ based on decay of radioactive material. Early applications of radiometric dating used the decomposition of uranium-238 first to thorium-234 and subsequently to lead-206. More recently potassium-40 decomposition has been found to be useful (and zircon decay is currently the best available).

Potassium-40 decomposes to both argon-40 and calcium-40 according to



When deposited, volcanic rock contains significant amounts of ^{40}K but is essentially free of ^{40}Ar because ^{40}Ar is a gas that escapes the rock under volcanic conditions. Once cooled, some volcanic rock will become essentially sealed capsules that contain ^{40}K and retain the ^{40}Ar that derives from decomposition of the ^{40}K .

Mathematical Model 5.5.3 Potassium-40 decomposition. The rate of disintegration of ^{40}K is proportional to the amount of ^{40}K present.

If we let $K(t)$ be the amount of ^{40}K present t years after deposition of rock of volcanic origin and K_0 the initial amount of ^{40}K present, then

$$K(0) = K_0, \quad K'(t) = -r K(t)$$

where r is a positive constant. The minus sign reflects the disintegration of ^{40}K . From the equation we may write

$$K(t) = K_0 e^{-rt}$$

The half-life of ^{40}K is 1.28×10^9 years, meaning that 1.28×10^9 years after deposition of the volcanic rock, the amount of ^{40}K in the rock will be $\frac{1}{2}K_0$. We use this information to evaluate r .

$$\frac{1}{2}K_0 = K_0 e^{-r \cdot 1280000000}$$

$$\frac{1}{2} = e^{-r \cdot 1280000000}$$

$$\ln \frac{1}{2} = -r \cdot 1280000000$$

$$r = \frac{\ln 2}{1280000000}$$

$$K(t) = K_0 e^{-\frac{\ln 2}{1280000000}t}$$

Problem. Suppose a rock sample is found to have 5×10^{14} ^{40}K atoms and 2×10^{13} ^{40}Ar atoms. What is the age of the rock?

Solution. It is necessary to assume⁷ that all of the ^{40}Ar derives from the ^{40}K , and that there has been no leakage of ^{40}K or ^{40}Ar into or out of the rock. Assuming so, then the number of ^{40}K atoms

⁵Charles Darwin wrote in the Origin of Species that Earth was several hundred million years old, but he was opposed in 1863 by a dominant physical scientist, William Thompson (later to become Lord Kelvin) who estimated that Earth was between 24 and 400 million years old. His estimate was based on his calculation of the time it would take for Earth to cool from molten rock to today's temperatures in the upper layers of the Earth. See article by Philip England, Peter Molnar, and Frank Richter, GSA Today, 17, 1 (January 1, 2007).

⁶Wikipedia

⁷Because ^{40}Ar is a gas at the temperatures that the rock was formed, no ^{40}Ar was originally in the rock.

that have decomposed (to either ^{40}Ca or ^{40}Ar) must be nine times the number of ^{40}Ar atoms, or $9(2 \times 10^{13}) = 1.8 \times 10^{14}$ atoms. Therefore

$$K_0 = 5 \times 10^{14} + 1.8 \times 10^{14} = 6.8 \times 10^{14}$$

and

$$K(t) = 6.8 \times 10^{14} e^{-\frac{\ln 2}{1280000000} t}$$

We want the value of t for which $K(t) = 5 \times 10^{14}$. Therefore,

$$5 \times 10^{14} = 6.8 \times 10^{14} e^{-\frac{\ln 2}{1280000000} t}$$

$$\frac{5}{6.8} = e^{-\frac{\ln 2}{1280000000} t}$$

$$\ln \frac{5}{6.8} = -\frac{\ln 2}{1280000000} t$$

$$t = 568,000,000$$

The rock is about 568 million years old. ■

5.5.1 Two primitive modeling concepts.

Primitive Concept 1. Suppose you have a barrel (which could just as well be a blood cell, stomach, liver, or lake or ocean or auditorium) and $A(t)$ liters is the amount of water (glucose, plasma, people) in the barrel at time t minutes. If water is running into the barrel at a rate R_1 liters/minute and leaking out of the barrel at a rate R_2 liters/minute then

$$\begin{array}{rcccl} \text{Rate of change of water} & = & \text{Rate water enters} & - & \text{Rate water leaves} \\ \text{in the barrel} & & \text{the barrel} & & \text{the barrel} \\ \\ A'(t) & = & R_1 & - & R_2 \\ \\ \frac{\text{L}}{\text{min}} & & \frac{\text{L}}{\text{min}} & & \frac{\text{L}}{\text{min}} \end{array}$$

Primitive Concept 2. Similar to Primitive Concept 1 except that there is salt in the water. Suppose $S(t)$ is the amount in grams of salt in the barrel and C_1 is the concentration in grams/liter of salt in the stream entering the barrel and C_2 is the concentration of salt in grams/liter in the stream leaving the barrel. Then

$$\begin{array}{rcccl} \text{Rate of change of salt} & = & \text{Rate salt enters} & - & \text{Rate salt leaves} \\ \text{in the barrel} & & \text{the barrel} & & \text{the barrel} \\ \\ S'(t) & = & C_1 R_1 & - & C_2 R_2 \\ \\ \frac{\text{g}}{\text{min}} & & \frac{\text{g}}{\text{L}} \frac{\text{L}}{\text{min}} & & \frac{\text{g}}{\text{L}} \frac{\text{L}}{\text{min}} \end{array}$$

Observe that the units are g/m on both sides of the equation. Maintaining a balance in units often helps to find the correct equation.

Example 5.5.3 Suppose a runner is exhaling at the rate of 2 liters per second. Then the amount of air in her lungs is decreasing at the rate of two liters per second. If, furthermore, the CO₂ partial pressure in the exhaled air is 50 mm Hg (approx 0.114 g CO₂/liter of air at body temperature of 310 K)⁸, then she is exhaling CO₂ at the rate of 0.114 g/liter × 2 liters/sec = 0.228 g/sec. ■

Example 5.5.4 Classical Washout Curve. A barrel contains 100 liters of water and 300 grams of salt. You start a stream of pure water flowing into the barrel at 5 liters per minute, and a compensating stream of salt water flows from the barrel at 5 liters per minute. The solution in the barrel is ‘well stirred’ so that the salt concentration is uniform throughout the barrel at all times. Let $S(t)$ be the amount of salt (grams) in the barrel t minutes after you start the flow of pure water into the barrel.

Explore 5.5.3 Draw a graph of what you think will be the graph of $S(t)$. In doing so consider

- What is $S(0)$?
- Does $S(t)$ increase or decrease?
- Will there be a time, t_* , for which $S(t_*) = 0$? If so, what is t_* ?

■

Solution. First let us analyze S . We use Primitive Concept 2. The concentration of salt in the water flowing into the barrel is 0. The concentration of salt in the water flowing out of the barrel is the same as the concentration $C(t)$ of salt in the barrel which is

$$C(t) = \frac{S(t)}{100} \text{ g/L}$$

Therefore

$$\begin{array}{rclcl} \text{Rate of change of salt} & = & \text{Rate salt enters} & - & \text{Rate salt leaves} \\ \text{in the barrel} & & \text{the barrel} & & \text{the barrel} \\ \\ S'(t) & = & C_1 R_1 & - & C_2 R_2 \\ \\ S'(t) & = & 0 \times 5 & - & \frac{S(t)}{100} \frac{\text{gr}}{\text{L}} \times 5 \frac{\text{L}}{\text{min}} \end{array}$$

Furthermore, $S(0) = 300$. Thus

$$\begin{aligned} S(0) &= 300 \\ S'(t) &= -0.05S(t). \end{aligned}$$

From the Exponential Growth and Decay property 5.5.2,

$$S(t) = 300e^{-0.05t}$$

Explore 5.5.4 . Draw the graph of $S(t) = 300e^{-0.05t}$ and compare it with the graph you drew in Explore 5.5.3. ■ ■

8

$$\frac{50}{760} \text{ A} \times 1 \text{ liter} \times 44 \text{ mol wt} \\ 0.08206 \text{ gas const} \times 310 \text{ K} = 0.114 \text{ g}$$

Example 5.5.5 Classical Saturation Curve.

Problem. Suppose a 100 liter barrel is full of pure water and at time $t = 0$ minutes a stream of water flowing at 5 liters per minute and carrying 3 g/liter of salt starts flowing into the barrel. Assume the salt is well mixed in the barrel and water overflows at the rate of 5 liters per minute. Let $S(t)$ be the amount of salt in the barrel at time t minutes after the salt water starts flowing in.

Explore 5.5.5 Draw a graph of what you think will be the graph of $S(t)$. In doing so consider

- What is $S(0)$?
- Does $S(t)$ increase or decrease?
- Is there an upper bound on $S(t)$, the amount of salt in the barrel that will be in the barrel?

■

Solution: We analyze S ; again we use Primitive Concept 2. The concentration of salt in the inflow is 3 g/liter. The concentration $C(t)$ of salt in the tank at time t minutes is

$$C(t) = \frac{S(t)}{100}$$

The salt concentration in the outflow will also be $C(t)$. Therefore

Rate of change of salt in the barrel	=	Rate salt enters the barrel	−	Rate salt leaves the barrel
$S'(t)$	=	$C_1 R_1$	−	$C_2 R_2$
$S'(t)$	=	3×5	−	$\frac{S(t)}{100} 5$
$\frac{\text{g}}{\text{min}}$		$\frac{\text{g}}{\text{L}} \frac{\text{L}}{\text{min}}$		$\frac{\text{g}}{\text{L}} \frac{\text{L}}{\text{min}}$

Initially the barrel is full of pure water, so

$$S(0) = 0$$

We now have

$$\begin{aligned} S(0) &= 0 \\ S'(t) &= 15 - 0.05 S(t) \end{aligned} \tag{5.22}$$

This equation is not in the form of $P'(t) = kP(t)$ because of the 15. Proceed as follows.

Equilibrium. Ask, 'At what value, E , of $S(t)$ would $S'(t) = 0$?' That would require

$$0 = 15 - 0.05 E = 0, \text{ or } E = 300 \text{ g.}$$

$E = 300$ g is the *equilibrium level* of salt in the barrel. We focus attention on the difference, $D(t)$, between the equilibrium level and the current level of salt. Thus

$$D(t) = 300 - S(t) \quad \text{and} \quad S(t) = 300 - D(t)$$

Now,

$$D(0) = 300 - S(0) = 300 - 0 = 300$$

Furthermore,

$$S'(t) = [300 - D(t)]' = -D'(t)$$

We substitute into Equations 5.22

$$\begin{aligned} S(0) &= 0 & D(0) &= 300 \\ S'(t) &= 15 - 0.05 S(t) & -D'(t) &= 15 - 0.05 (300 - D(t)) \end{aligned}$$

The equations for D become

$$\begin{aligned} D(0) &= 300 \\ D'(t) &= -0.05 D(t) \end{aligned}$$

This is in the form of the Exponential Growth and Decay Property 5.5.2, and we write

$$D(t) = 300 e^{-0.05 t}$$

Returning to $S(t) = 300 - D(t)$ we write

$$S(t) = 300 - D(t) = 300 - 300 e^{-0.05 t}$$

The graph of $S(t) = 300 - 300 e^{-0.05 t}$ is shown in Figure 5.3. Curiously, the graph of $S(t)$ is also called an *exponential decay curve*. $S(t)$ is not decaying at all; $S(t)$ is increasing. What is decaying exponentially is $D(t)$, the remaining salt capacity. ■

Explore 5.5.6 Show that if $S(t) = 300 - 300 e^{-0.05 t}$, then

$$S(0) = 0, \quad \text{and} \quad S'(t) = 15 - 0.05 S(t).$$

■

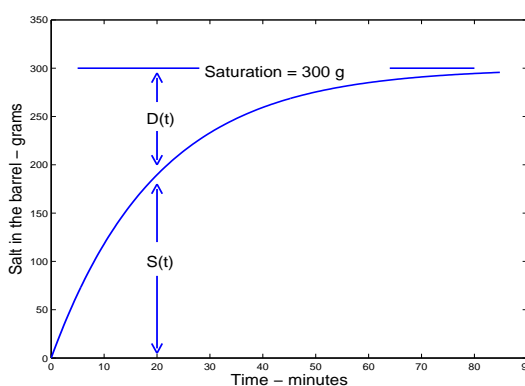

Figure 5.3: The graph of $S(t) = 300 - 300 e^{-0.05 t}$ depicting the amount of salt in a barrel initially filled with 100 liters of pure water and receiving a flow of 5 L/m carrying 3 g/L. $D(t) = 300 - S(t)$.

5.5.2 Continuous-space analysis of light depletion.

As observed in Chapter 1, light intensity decreases as one descends from the surface of a lake or ocean. There we divided the water into discrete layers and it was assumed that each layer absorbs a fixed fraction, F , of the light that enters it from above. This hypothesis led to the difference equation

$$I_{d+1} - I_d = -F I_d$$

Light is actually absorbed continuously as it passes down through a (homogeneous) water medium, not in discrete layers. We examine the light intensity, $I(x)$, at a distance, x meters, below the surface of a lake or ocean, assuming that the light intensity penetrating the surface is a known quantity, I_0 .

We start by testing an hypothesis about light transmission in water that appears different from the hypothesis we arrived at in Chapter 1:

Mathematical Model 5.5.4 Light Absorbance: The amount of light absorbed by a (horizontal) layer of water is proportional to the thickness of the layer and to the amount of light entering the layer (see Figure 5.4).

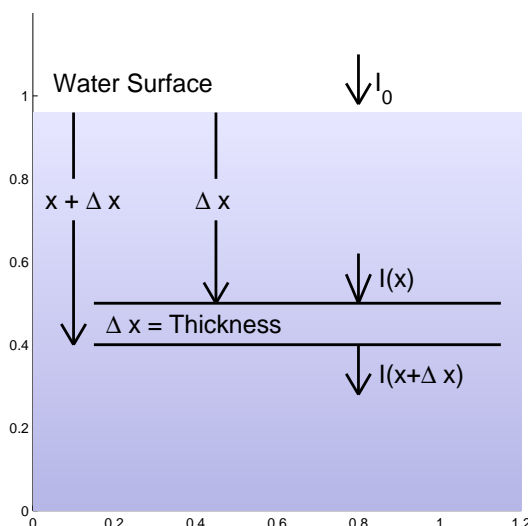

Figure 5.4: Diagram of light depletion below the surface of a lake or ocean. $I(x)$ is light intensity at depth x due to light of intensity I_0 just below the surface of the water.

The mathematical model of light absorbance implies, for example, that

1. The light absorbed by a water layer of thickness 2Δ is twice the light absorbed by a water layer of thickness Δ and
2. A layer that absorbs 10% of a bright light will absorb 10% of a dim light.

We know from experimental evidence that implication (1) is approximately true for thin layers and for low levels of turbidity. Implication (2) is valid for a wide range of light intensities.

Double Proportionality. From the mathematical model of light absorbance the light absorbed by a layer is proportional to two things, the thickness of the layer and the intensity of the light entering the layer. We handle this double proportionality by assuming that the amount of light

absorbed in a layer is proportional to the **product** of the thickness of the layer and the intensity of the light incident to the layer. That is, there is a number, K , such that if $I(x)$ is the light intensity at depth x and $I(x + \Delta x)$ is the light intensity at depth $x + \Delta x$, then

$$I(x + \Delta x) - I(x) \doteq -K \Delta x \times I(x) \quad (5.23)$$

The product, $K \Delta x \times I(x)$, has the advantage that

1. For fixed incident light intensity, $I(x)$, the light absorbed, $I(x + \Delta x) - I(x)$, is proportional to the thickness, Δx , (proportionality constant = $-K I(x)$) and
2. For fixed thickness Δx , the light absorbed is proportional to the incident light, $I(x)$ (proportionality constant = $-K \Delta x$).

Equation 5.23 can be rearranged to

$$\frac{I(x + \Delta x) - I(x)}{\Delta x} \doteq -KI(x)$$

The approximation (\doteq) improves as the layer thickness, Δx , approaches zero.

$$\text{As } \Delta x \rightarrow 0 \quad \frac{I(x + \Delta x) - I(x)}{\Delta x} \rightarrow I'(x)$$

and we conclude that

$$I'(x) = -KI(x) \quad (5.24)$$

The Exponential Growth and Decay Property 5.5.2 implies that

$$\text{because } I'(x) = -K I(x), \quad I(x) = I_0 e^{-Kx} \quad (5.25)$$

Example 5.5.6 Assume that 1000 w/m² of light is striking the surface of a lake and that 40% of that light is reflected back into the atmosphere. We first solve the initial value problem

$$\begin{aligned} I(0) &= 600 \\ I'(x) &= -K I(x) \end{aligned}$$

to get

$$I(x) = 600 e^{-Kx}$$

If we have additional information that, say, the light intensity at a depth of 10 meters is 400 W/m² we can find the value of K . It must be that

$$I(10) = 600 e^{-K \times 10} = 400$$

The only unknown in the last equation is K , and we solve

$$\begin{aligned} 600e^{-K \times 10} &= 400 \\ e^{-10K} &= 400/600 = 2/3 \\ \ln(e^{-10K}) &= \ln(2/3) \\ -10K &= \ln(2/3) \\ K &\doteq 0.040557 \end{aligned}$$

Thus we would say that

$$I(x) = 600 e^{-0.040557 x}$$

If we know, for example, that 30 W/m² of light are required for a certain species of coral to grow, we can ask for the maximum depth, \bar{x} , at which we might find that species. We would solve

$$\begin{aligned} I(\bar{x}) &= 30 \\ 600 e^{-0.040557 \bar{x}} &= 30 \\ \ln(e^{-0.040557 \bar{x}}) &= \ln(30/600) \\ -0.040557 \bar{x} &= \ln(1/20) \\ \bar{x} &= 73.9 \text{ meters} \end{aligned}$$

5.5.3 Doubling time and half-life

Suppose k and C are positive numbers. The *doubling time* of $F(t) = Ce^{kt}$ is a number t_{dbl} such that

$$\text{for any time } t \quad F(t + t_{dbl}) = 2 \times F(t).$$

That there is such a number follows from

$$F(t + t_{dbl}) = 2 \times F(t)$$

$$C e^{k(t+t_{dbl})} = 2 C e^{kt}$$

$$C e^{kt} e^{kt_{dbl}} = 2 C e^{kt}$$

$$e^{kt_{dbl}} = 2$$

$$t_{dbl} = \frac{\ln 2}{k}. \tag{5.26}$$

The *half-life* of $F(t) = C e^{-kt}$ is a number t_{half} , usually written as $t_{1/2}$, such that

$$\text{for any time } t \quad F(t + t_{1/2}) = \frac{1}{2} F(t).$$

Using steps similar to those for the doubling time you can find that

$$t_{1/2} = \frac{\ln 2}{k}. \tag{5.27}$$

Explore 5.5.7 Write the steps similar to those for the doubling time to show that $t_{1/2} = (\ln 2)/k$.

■

In Figure 5.5A is a graph of the bacterial density from Table 1.1 and of the equation

$$\text{Abs} = 0.022 e^{0.0315 t}, \quad t_{dbl} = \frac{\ln 2}{0.0315} = 22.0 \text{ minutes.}$$

The bacterial density doubles every 22 minutes, as illustrated for the intervals [26,48] minutes and [48,70] minutes.

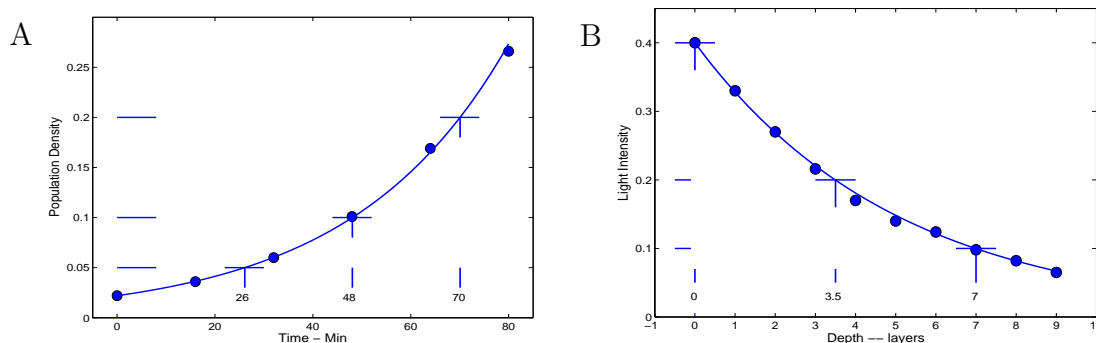

Figure 5.5: A. Bacterial population density and $ABS=0.022e^{0.0315t}$, which has doubling time of 22 minutes. B. Light depletion and $I_d = 0.4e^{-0.196d}$ which has a 'half life' of 3.5 meters.

In Figure 5.5B is a graph of light intensity decay from Figure 1.10 (repeated in Figure 5.6) and of the Equation 1.15

$$I_d = 0.400 \times 0.82^d$$

Because $0.82 = e^{\ln 0.82} = e^{-0.198}$,

$$I_d = 0.400 e^{-0.198d} \quad \text{and} \quad d_{1/2} = \frac{\ln 2}{0.198} = 3.5$$

Every 3.5 layers of muddy water the light intensity decays by one-half. $d_{1/2}$ is a distance and might be called 'half depth' rather than 'half life.' 'Half life' is the term used for all exponential decay, however, and you are well advised to use it.

Example 5.5.7 Problem. Suppose a patient is prescribed to take 80 mg of Sotolol, a drug that regularizes heart beat, once per day. Sotolol has a half-life in the body of 12 hrs. Compute the daily fluctuations of sotolol.

Solution. Let s_t^- be the amount of sotolol in the body at time, t , just before the sotolol pill is taken and s_t^+ be the amount of sotolol in the body at time t just after the sotolol pill is taken. Then

$$s_0^- = 0, \quad s_0^+ = 80, \quad s_1^- = \frac{1}{4} s_0^+ = \frac{1}{4} 80 = 20.$$

$$s_t^+ = s_t^- + 80 \quad s_{t+1}^- = \frac{1}{4} s_t^+ = \frac{1}{4} (s_t^- + 80) = \frac{1}{4} s_t^- + 20$$

After some days, s_t^- will reach approximate equilibrium, E : $s_t^- \doteq E$ and $s_{t+1}^- \doteq E$.

$$s_0^- = 0, \quad s_{t+1}^- = \frac{1}{4} s_t^- + 20, \quad E = \frac{1}{4} E + 20, \quad E = 26.67$$

$$\text{Thus, approximately,} \quad s_t^- = E = 26.67, \quad s_t^+ = s_t^- + 80 = E + 80 = 106.67.$$

so the system oscillates between 26.67 mg and 106.67 mg, a four to one ratio.

You are asked to compare this with taking 40 mg of Sotolol twice per day in Exercise 5.5.6

5.5.4 Semilogarithm and LogLog graphs.

Functions $P(t)$ that satisfy an equation $P'(t) = k P(t)$ may be written $P(t) = P_0 e^{kt}$ and will satisfy the relation $\ln P(t) = (\ln P_0) + kt$. The graph of $\ln P(t)$ vs t is a straight line with intercept $\ln P_0$ and slope k . Similarly, if $P'(t) = -k P(t)$, in rectilinear coordinates, the graph of

In $P(t)$ vs t is a straight line with slope $-k$. A scientist with data $t, P(t)$ that she thinks is exponential may plot the graph of $\ln P(t)$ vs t . If the graph is linear, then a fit of a line to that data will lead to an exponential relation of the form $P(t) = A e^{kt}$ or $P(t) = A e^{-kt}$. She may then search for a biological process that would justify a model $P'(t) = \pm k P(t)$.

Example 5.5.8 In Section 1.3 we showed the results of an experiment measuring the light decay as a function of depth. The data and a semilog graph of the data are shown in Figure 5.6.

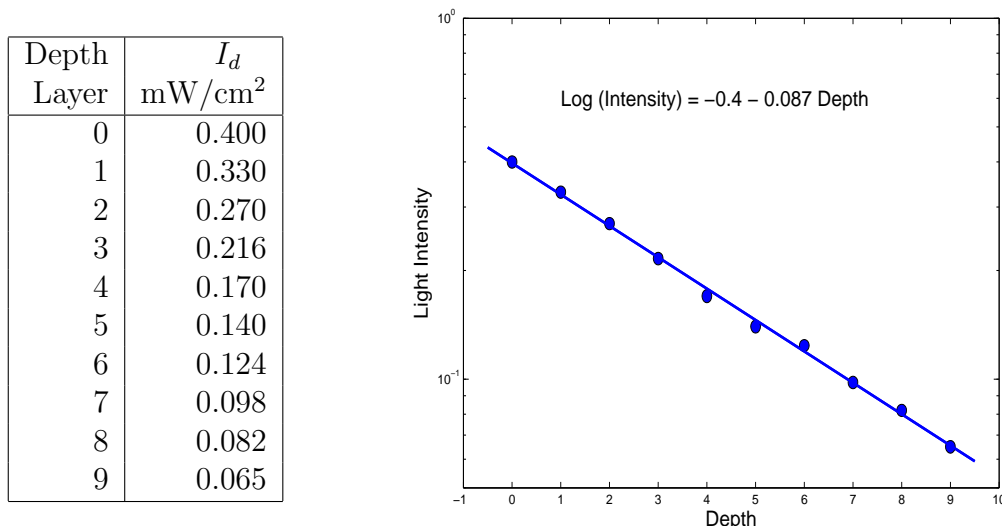

Figure 5.6: Data and a semilog graph of the data showing experimental results of measuring light decrease with depth of water.

As shown in the figure,

$$\log_{10} I_d = -0.4 - 0.087 d$$

is a good approximation to the data. Therefore

$$\begin{aligned} I_d &\doteq 10^{-0.4-0.087d} \\ &= 0.4 \times 0.82^d \end{aligned}$$

which is the same result obtained in Section 1.3. As shown in the previous subsection, the relation

$$I'(d) = -k I(d)$$

corresponds to a process underlying light depletion in water.

Explore 5.5.8 Do This. In Explore 1.6.1, you were given data for serum penicillin concentration during 30 minutes following a bolus penicillin injection and you may have found that $P_t = 200 \times 0.77^T$, where t denotes 5-minute intervals, $P_t = 200 \times 0.978^t$ where t denotes minutes, models the data very well. Additional data for the same experiment is shown in Figure 5.7.

- On a copy of Figure 5.7 plot the graph of $\log_{10} P_t = \log_{10} (200 \times 0.978^t)$ versus time, t in minutes, for $0 \leq t \leq 60$.
- Why is the previous graph a straight line?
- The two graphs match well for only the first 30 minutes. It is worth a good bit of your time thinking about an alternate model of penicillin pharmacokinetics that would explain the difference after 30 minutes.

Time (min)	Mezlocillin $\mu\text{g/ml}$	Time (min)	Mezlocillin $\mu\text{g/ml}$
0	200	60	21.3
5	151.6	90	12.5
10	118.0	120	8.2
15	93.0	180	3.7
20	74.4	240	1.7
30	49.8	300	0.8
45	30.7		

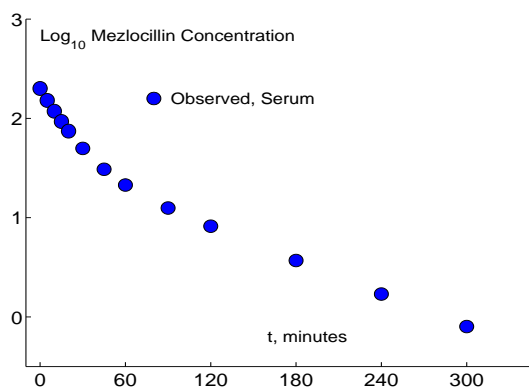

Figure 5.7: : Penicillin concentration following a bolus injection of 2 gm of mezlocillin.

5.5.5 Relative Growth Rates and Allometry.

If y is a positive function of time, the relative growth rate of y is

$$\frac{y'(t)}{y(t)} \quad \text{Relative Growth Rate.} \quad (5.28)$$

The relative growth rate of y is sometimes called the *fractional growth rate* or the *logarithmic growth rate*.

Definition 5.5.1 Allometry. . Two functions, x and y , of time are said to be allometrically related if there are numbers C and a such that

$$y(t) = C (x(t))^a. \quad (5.29)$$

If x and y are allometric then

$$\log y = \log(C x^a) = \log C + a \log x, \quad (5.30)$$

for any base of log. Therefore if $\log y$ is plotted *vs* $\log x$ the graph should be a straight line.

Explore 5.5.9 Show that if x and y satisfy Equation 5.30, $\log y(t) = \log C + a \log x(t)$, then

$$\frac{y'(t)}{y(t)} = a \frac{x'(t)}{x(t)}.$$

Conclude that if x and y are allometric then the relative growth rate of y is proportional to the relative growth rate of x . ■

Shown in Figure 5.8 is a graph of \log_{10} of the weight of large mouth bass *vs* \log_{10} of their length⁹. The data appear linear and we conclude that the weight is allometric to the length. An equation of a line close to the data is

$$\frac{\log y - 1.05}{\log x - 2.0} = \frac{2.6 - 1.05}{2.5 - 2.0}, \quad \log y = -5.75 + 3.1 \log x$$

Then

$$y = 10^{-5.75} x^{3.1}$$

The weights of the bass are approximately proportional to the cube of the lengths. This is consistent with the fact that the volume of a cube is equal to the cube of the length of an edge. Many interesting allometric relations are not supported by underlying models, however (Exercises 5.5.29 and 5.5.30).

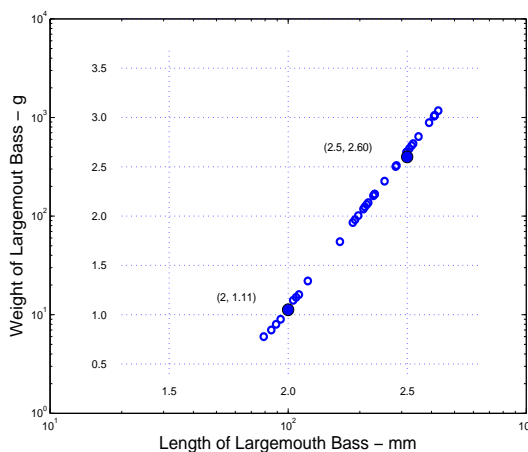

Figure 5.8: Weight *vs* Length for large mouth bass plotted on a log-log graph.

Exercises for Section 5.5, The derivative equation $P'(t) = k P(t)$

Exercise 5.5.1 Write a solution for each of the following derivative equations. Sketch the graph of the solution. For each, find the doubling time, t_{dbl} , or half life, $t_{1/2}$, which ever is applicable.

- | | | | |
|----------------|--------------------|----------------|---------------------|
| a. $P(0) = 5$ | $P'(t) = 2P(t)$ | b. $P(0) = 5$ | $P'(t) = -2P(t)$ |
| c. $P(0) = 2$ | $P'(t) = 0.1P(t)$ | d. $P(0) = 2$ | $P'(t) = -0.1P(t)$ |
| e. $P(0) = 10$ | $P'(t) = P(t)$ | f. $P(0) = 10$ | $P'(t) = -P(t)$ |
| g. $P(0) = 0$ | $P'(t) = 0.01P(t)$ | h. $P(0) = 0$ | $P'(t) = -0.01P(t)$ |

Exercise 5.5.2 Write a solution for each of the following derivative equations. Sketch the graph of the solution. For each, find the half life, $t_{1/2}$, which is the time required to 'move half way toward equilibrium.'

⁹Data from Robert Summerfelt, Iowa State University.

Recall the solution in Example 5.5.5 to solve $S'(t) = 15 - 0.05S(t)$.

- a. $S(0) = 0$ $S'(t) = 10 - 2S(t)$ b. $S(0) = 2$ $S'(t) = 10 - 2S(t)$
 c. $S(0) = 5$ $S'(t) = 10 - 2S(t)$ d. $S(0) = 10$ $S'(t) = 10 - 2S(t)$
 e. $S(0) = 0$ $S'(t) = 20 - S(t)$ f. $S(0) = 10$ $S'(t) = 20 - S(t)$
 g. $S(0) = 20$ $S'(t) = 20 - S(t)$ h. $S(0) = 30$ $S'(t) = 20 - S(t)$

Exercise 5.5.3 Find values of C and k so that $P(t) = Ce^{kt}$ matches the data.

- a. $P(0) = 5$ $P(2) = 10$ b. $P(0) = 10$ $P(2) = 5$
 c. $P(0) = 2$ $P(5) = 10$ d. $P(0) = 10$ $P(5) = 10$
 e. $P(0) = 5$ $P(2) = 2$ f. $P(0) = 8$ $P(10) = 6$
 g. $P(1) = 5$ $P(2) = 10$ h. $P(2) = 10$ $P(10) = 20$

Exercise 5.5.4 Do Explore 5.5.2. In particular, read the paragraph about the ambiguous use of the variable, t .

Exercise 5.5.5 Suppose a barrel has 100 liters of water and 400 grams of salt and at time $t = 0$ minutes a stream of water flowing at 5 liters per minute and carrying 3 g/liter of salt starts flowing into the barrel, the barrel is well mixed, and a stream of water and salt leaves the barrel at 5 liters per minute. What is the amount of salt in the barrel t minutes after the flow begins? Draw a candidate solution graph for this problem before computing the solution.

Exercise 5.5.6 In Example 5.5.7 it was shown that in a patient who takes 80 mg of sotolol once per day, the daily fluctuation of sotolol is from 26.7 mg to 106.7 mg. Sotolol has a half-life in the body of 12 hours. What is the fluctuation of sotolol in the body if the patient takes two 40 mg of sotolol at 12 hour intervals in the day? Would you recommend two 40 mg per day rather than one 80 mg pill per day?

Exercise 5.5.7 Suppose it is determined that 30 mg of sotolol is sufficient to control irregular heart beats. What size, X , of sotolol pill should a patient take twice per day to insure that the equilibrium value of sotolol immediately before taking each pill is at least 30 mg?

Exercise 5.5.8 A patient takes 10 mg of coumadin once per day to reduce the probability that he will experience blood clots. The half-life of coumadin in the body is 40 hours. What level, H , of coumadin will be accumulated from previous ingestion of pills and what will be the daily fluctuation of coumadin in the body.

Exercise 5.5.9 Plot semilog graphs of the data sets in Table Ex. 5.5.9 and decide which ones appear to be approximately exponential. For those that appear to be exponential, find numbers, C and k , so that

$$P(t) = Ce^{kt}$$

approximates the the data.

Table for Exercise 5.5.9 Data sets for Exercise 5.5.9

a.	b.	c.	d.	e.																																																																						
<table style="border-collapse: collapse; width: 100%;"> <tr><th style="border: 1px solid black; padding: 2px;">t</th><th style="border: 1px solid black; padding: 2px;">$P(t)$</th></tr> <tr><td style="border: 1px solid black; padding: 2px;">0</td><td style="border: 1px solid black; padding: 2px;">2.0</td></tr> <tr><td style="border: 1px solid black; padding: 2px;">1</td><td style="border: 1px solid black; padding: 2px;">2.1</td></tr> <tr><td style="border: 1px solid black; padding: 2px;">2</td><td style="border: 1px solid black; padding: 2px;">2.8</td></tr> <tr><td style="border: 1px solid black; padding: 2px;">3</td><td style="border: 1px solid black; padding: 2px;">4.7</td></tr> <tr><td style="border: 1px solid black; padding: 2px;">4</td><td style="border: 1px solid black; padding: 2px;">8.4</td></tr> <tr><td style="border: 1px solid black; padding: 2px;">5</td><td style="border: 1px solid black; padding: 2px;">14.5</td></tr> </table>	t	$P(t)$	0	2.0	1	2.1	2	2.8	3	4.7	4	8.4	5	14.5	<table style="border-collapse: collapse; width: 100%;"> <tr><th style="border: 1px solid black; padding: 2px;">t</th><th style="border: 1px solid black; padding: 2px;">$P(t)$</th></tr> <tr><td style="border: 1px solid black; padding: 2px;">0</td><td style="border: 1px solid black; padding: 2px;">6.00</td></tr> <tr><td style="border: 1px solid black; padding: 2px;">2</td><td style="border: 1px solid black; padding: 2px;">4.35</td></tr> <tr><td style="border: 1px solid black; padding: 2px;">4</td><td style="border: 1px solid black; padding: 2px;">2.97</td></tr> <tr><td style="border: 1px solid black; padding: 2px;">6</td><td style="border: 1px solid black; padding: 2px;">2.17</td></tr> <tr><td style="border: 1px solid black; padding: 2px;">8</td><td style="border: 1px solid black; padding: 2px;">1.65</td></tr> <tr><td style="border: 1px solid black; padding: 2px;">10</td><td style="border: 1px solid black; padding: 2px;">1.25</td></tr> </table>	t	$P(t)$	0	6.00	2	4.35	4	2.97	6	2.17	8	1.65	10	1.25	<table style="border-collapse: collapse; width: 100%;"> <tr><th style="border: 1px solid black; padding: 2px;">t</th><th style="border: 1px solid black; padding: 2px;">$P(t)$</th></tr> <tr><td style="border: 1px solid black; padding: 2px;">0</td><td style="border: 1px solid black; padding: 2px;">2.00</td></tr> <tr><td style="border: 1px solid black; padding: 2px;">5</td><td style="border: 1px solid black; padding: 2px;">2.83</td></tr> <tr><td style="border: 1px solid black; padding: 2px;">10</td><td style="border: 1px solid black; padding: 2px;">4.00</td></tr> <tr><td style="border: 1px solid black; padding: 2px;">15</td><td style="border: 1px solid black; padding: 2px;">5.67</td></tr> <tr><td style="border: 1px solid black; padding: 2px;">20</td><td style="border: 1px solid black; padding: 2px;">8.00</td></tr> <tr><td style="border: 1px solid black; padding: 2px;">25</td><td style="border: 1px solid black; padding: 2px;">11.31</td></tr> </table>	t	$P(t)$	0	2.00	5	2.83	10	4.00	15	5.67	20	8.00	25	11.31	<table style="border-collapse: collapse; width: 100%;"> <tr><th style="border: 1px solid black; padding: 2px;">t</th><th style="border: 1px solid black; padding: 2px;">$P(t)$</th></tr> <tr><td style="border: 1px solid black; padding: 2px;">0</td><td style="border: 1px solid black; padding: 2px;">2.00</td></tr> <tr><td style="border: 1px solid black; padding: 2px;">3</td><td style="border: 1px solid black; padding: 2px;">1.00</td></tr> <tr><td style="border: 1px solid black; padding: 2px;">6</td><td style="border: 1px solid black; padding: 2px;">0.67</td></tr> <tr><td style="border: 1px solid black; padding: 2px;">9</td><td style="border: 1px solid black; padding: 2px;">0.50</td></tr> <tr><td style="border: 1px solid black; padding: 2px;">12</td><td style="border: 1px solid black; padding: 2px;">0.40</td></tr> <tr><td style="border: 1px solid black; padding: 2px;">15</td><td style="border: 1px solid black; padding: 2px;">0.33</td></tr> </table>	t	$P(t)$	0	2.00	3	1.00	6	0.67	9	0.50	12	0.40	15	0.33	<table style="border-collapse: collapse; width: 100%;"> <tr><th style="border: 1px solid black; padding: 2px;">t</th><th style="border: 1px solid black; padding: 2px;">$P(t)$</th></tr> <tr><td style="border: 1px solid black; padding: 2px;">0</td><td style="border: 1px solid black; padding: 2px;">2.00</td></tr> <tr><td style="border: 1px solid black; padding: 2px;">3</td><td style="border: 1px solid black; padding: 2px;">1.00</td></tr> <tr><td style="border: 1px solid black; padding: 2px;">6</td><td style="border: 1px solid black; padding: 2px;">0.50</td></tr> <tr><td style="border: 1px solid black; padding: 2px;">9</td><td style="border: 1px solid black; padding: 2px;">0.25</td></tr> <tr><td style="border: 1px solid black; padding: 2px;">12</td><td style="border: 1px solid black; padding: 2px;">0.13</td></tr> <tr><td style="border: 1px solid black; padding: 2px;">15</td><td style="border: 1px solid black; padding: 2px;">0.06</td></tr> </table>	t	$P(t)$	0	2.00	3	1.00	6	0.50	9	0.25	12	0.13	15	0.06
t	$P(t)$																																																																									
0	2.0																																																																									
1	2.1																																																																									
2	2.8																																																																									
3	4.7																																																																									
4	8.4																																																																									
5	14.5																																																																									
t	$P(t)$																																																																									
0	6.00																																																																									
2	4.35																																																																									
4	2.97																																																																									
6	2.17																																																																									
8	1.65																																																																									
10	1.25																																																																									
t	$P(t)$																																																																									
0	2.00																																																																									
5	2.83																																																																									
10	4.00																																																																									
15	5.67																																																																									
20	8.00																																																																									
25	11.31																																																																									
t	$P(t)$																																																																									
0	2.00																																																																									
3	1.00																																																																									
6	0.67																																																																									
9	0.50																																																																									
12	0.40																																																																									
15	0.33																																																																									
t	$P(t)$																																																																									
0	2.00																																																																									
3	1.00																																																																									
6	0.50																																																																									
9	0.25																																																																									
12	0.13																																																																									
15	0.06																																																																									

Exercise 5.5.10 Shown in Table Ex. 5.5.10 data from *V. natriegens* growth reported in Chapter 1 on page 4. Find numbers, C and k , so that

$$P(t) = Ce^{kt}$$

approximates the the data. Use your values of C and k and compute $P(0)$, $P(16)$, $P(32)$, $P(48)$, and $P(64)$ and compare them with the observed values in the Table Ex. 5.5.10.

Table for Exercise 5.5.10 Cell density of *V. natriegens* measured as light absorbance at 16-minute time increments.

pH 6.25	
Time (min)	Population Density
0	0.022
16	0.036
32	0.060
48	0.101
64	0.169

Exercise 5.5.11 In Section 1.3 we found from the discrete model of light extinction,

$$I_{d+1} = I_d - 0.18 I_d, \quad \text{that the solution} \quad I_{d+1} = 0.82 I_d$$

matched the data for light depletion in Figure 1.11.

Layer	0	1	2	3	4	5	6	7	8	9
Light Intensity	0.400	0.330	0.270	0.216	0.170	0.140	0.124	0.098	0.082	0.065

Light decrease in water is continuous, however. Find a value of k for which the solution to the continuous model, $I'(x) = -kI(x)$, matches the data.

Exercise 5.5.12 In Section 1.6 you may have found that the solution, $y = 200 \times 0.77^{t/5}$, to the difference equation $P_{t+1} - P_t = -0.23 P_t$, approximates the data for penicillin concentration from Figure 1.18.

Time min	0	5	10	15	20
Penicillin Concentration	200	152	118	83	74

Penicillin clearance is continuous, however. Find a value of k for which the solution to $P'(t) = -k P(t)$ matches the data.

Exercise 5.5.13 David Ho and colleagues¹⁰ published the first study of HIV-1 dynamics within patients following treatment with an inhibitor of HIV-1 protease, ABT-538 which stops infected cells from producing new viral particles. Shown in Exercise Figure 5.5.13A is a graph of plasma viral load before and after ABT-treatment was begun on day 1 for patient number 409 and in Exercise Figure 5.5.13B is a semi-log graph of CD4 cell count following treatment.

- By what percent is viral load diminished from day-1 to day-12?
- The line in Figure 5.5.13A has an equation, $y = 5.9 - 0.19x$. Remember that $y = \log_{10} V$ and x is days. Find V_0 and m so that the graph of $V(t) = V_0 e^{-mt}$ in semilog coordinates is the line drawn in Exercise Figure 5.5.13A.
- What is the half-life of the viral load?
- From the previous step, $V'(t) = -0.43V(t)$. Suppose ABT-538 totally eliminates viral production during days 1 to 12. At what rate is the immune system of patient 409 eliminating virus before treatment.
- Assume that CD4 cell counts increase linearly and the equation in Figure 5.5.13B is $y = 9.2 + 15.8x$. At what rate are CD4 cells being produced? Remember that y is CD4 count per mm^3 and there are about $6 \times 10^6 \text{ mm}^3$ of blood in the human body.

After about 35 days, the HIV virus mutates into a form resistant to ABT-538 and pre-treatment viral loads soon return. Treatment with a protease inhibitor together with drugs that inhibit the translation of HIV RNA to DNA can decrease viral loads to levels below detection for the duration of treatment.

Figure for Exercise 5.5.13 A. Count of HIV viral load during administration of ABT-538. B. Count of helper t-cell during the same period. Note that if $\log_{10} (\text{RNA copies per ml}) = 4$, for example, then RNA copies per ml = 10^4 . See Exercise 5.5.13 Figures adapted by permission at no cost from Macmillan Publishing Group, Ltd. David D. Ho, Avidan U Neumann, Alan S. Perelson, Wen Chen, John M. Leonard & Martin Markowitz, *Nature* 373 (1995) 123:127 Copyright 1995 <http://www.nature.com>.

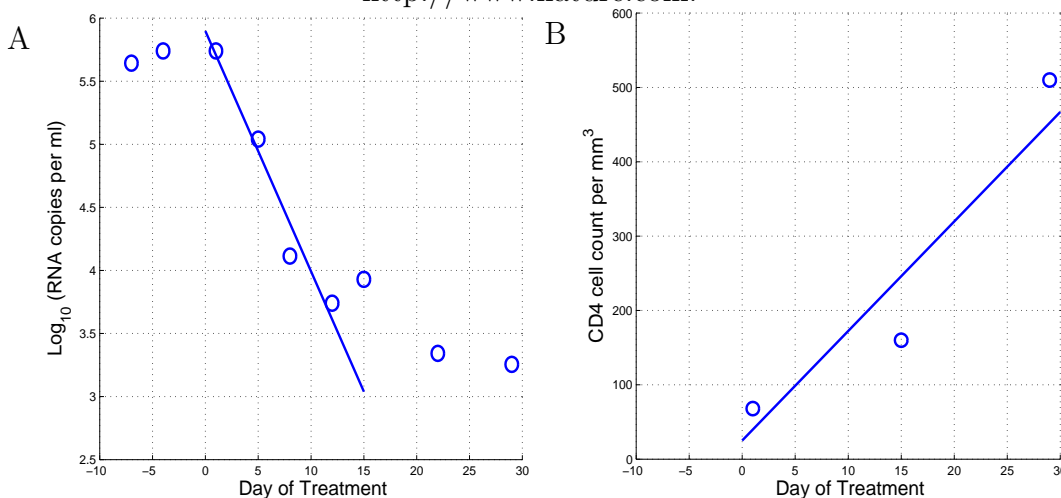

Exercise 5.5.14 You inject two grams of penicillin into the 6 liter vascular pool of a patient. Plasma circulates through the kidney at the rate of 1.2 liters/minute and the kidneys remove 20 per cent of the penicillin that passes through.

¹⁰David D. Ho, et al, *Nature* 373 (1995) 123:127.

1. Draw a schematic diagram showing the vascular pool and kidneys as separate entities, an artery leading from the vascular pool to the kidney and a vein leading from the kidney back to the vascular pool.
2. Let $P(t)$ be the amount of penicillin in the vascular pool t minutes after injection of penicillin. What is $P(0)$?
3. Use Primitive Concept 2 to write an equation for P' .
4. Write a solution to your equation.

Exercise 5.5.15 Suppose a rock sample is found to have $8.02 \mu\text{g}$ of ^{40}K and $7.56 \mu\text{g}$ of ^{40}Ar . What is the age of the rock?

Exercise 5.5.16 Suppose a rock sample is found to have 6.11 mg of ^{40}K and 0.05 mg of ^{40}Ar . What is the age of the rock?

Exercise 5.5.17 Rubidium-87 decomposes to strontium-87 with a half-life of 50×10^9 years. Fortunately, rubidium and potassium occur in the same rock types and in the same minerals, usually in the ratio of 1 ^{87}Rb atom to approximately 600 ^{40}K atoms. Age determined by rubidium-87 to strontium-87 decomposition is an excellent check of ^{40}K to ^{40}Ar ages. However, ^{87}Sr may be lost from the rock or may be present but not derived from ^{87}Rb so the ^{87}Rb to ^{87}Sr age may not be as accurate as the ^{40}K to ^{40}Ar age.

- a. Suppose a rock sample has 2.5×10^{11} atoms of ^{87}Rb and 1.5×10^{10} atoms of ^{87}Sr . What is the age of the rock?
- b. Suppose a rock sample has $6.4 \mu\text{g}$ of ^{87}Rb and $0.01 \mu\text{g}$ of ^{87}Sr . What is the age of the rock?

Exercise 5.5.18 A major advancement in archaeology was the development of carbon-14 dating in the 1950's by an American chemist Willard Libby, for which he received the 1960 Nobel Prize in Chemistry. Carbon-14 develops in the upper atmosphere as neutrons bombard nitrogen, and subsequently combines with oxygen to form carbon dioxide. About 1 in 10^{12} CO_2 atoms is formed with ^{14}C in today's atmosphere. Plants metabolize $^{14}\text{CO}_2$ (almost) as readily as $^{12}\text{CO}_2$, and resulting sugars are metabolized equally by animals that eat the plants. Consequently carbon from living material is 1 part in 10^{12} carbon-14. Upon death, no additional ^{14}C is absorbed into the material and ^{14}C gradually decomposes into nitrogen. Slightly confounding the use of radio carbon dating is the fact that the fraction of atmospheric $^{14}\text{CO}_2$ has not been historically constant at 1 molecule per 10^{12} molecules of $^{12}\text{CO}_2$.

Carbon-14 decomposes to nitrogen according to



where β^- denotes an electron and $\bar{\nu}$ denotes an antineutrino. One of the neutrons of ${}^6_{14}\text{C}$ loses an electron and becomes a proton.

Mathematical Model 5.5.5 Carbon-14 decay. The rate of decomposition of ${}^6_{14}\text{C}$ in a sample is proportional to the size of the sample. One-half of the atoms in a sample will decompose in 5730 years.

- a. Write and solve a derivative equation that will show for a sample of ^{14}C initially of size C_0 what the size will be t years later.
- b. In tissue living today, the amount of ^{14}C in one gram of carbon is approximately 10^{-12} grams. Assume for this problem that the same ratio in living material has persisted for the last 10,000 years. Also assume that upon death the only change in carbon of any form is the decrease in ^{14}C due to decomposition to nitrogen. Suppose a 100 gram sample of carbon from bone is found to have 3×10^{-11} grams of ^{14}C . What is the age of the sample?
- c. Suppose that during the time 10,000 years ago until 2,000 years ago the amount of ^{14}C in one gram of carbon in living tissue was approximately 1.05×10^{-12} grams. Suppose a 100 gram sample of carbon from bone is found to have 3×10^{-11} grams of ^{14}C . What is the age of the sample?

Exercise 5.5.19 Suppose solar radiation striking the ocean surface is 1250 W/m^2 and 20 percent of that energy is reflected by the surface of the ocean. Suppose also that 20 meters below the surface the light intensity is found to be 800 W/m^2 .

- a. Write an equation descriptive of the light intensity as a function of depth in the ocean.
- b. Suppose a coral species requires 100 W/m^2 light intensity to grow. What is the maximum depth at which that species might be found?

Exercise 5.5.20 In two bodies of water, L_1 and L_2 , the light intensities $I_1(x)$ and $I_2(x)$ as functions of depth x are measured simultaneously and found to be

$$I_1(x) = 800 e^{-0.04x} \quad \text{and} \quad I_2(x) = 700 e^{-0.05x}$$

Explain the differences in the two formulas in terms of the properties of water in the two bodies.

Exercise 5.5.21 A spectrophotometer is used to measure bacterial cell density in a growth medium. Light is passed through a sample of the medium and the amount of light that is absorbed by the medium is an indicator of cell density. As cell density increases the amount of light absorbed increases. A standard is established by passing a light beam of intensity I_0 through a 0.5 cm layer of the growth medium without bacteria and measuring the intensity I_{St} of the beam emerging from the medium. See Figure Ex. 5.5.21.

Figure for Exercise 5.5.21 Diagram of spectrophotometer. A light beam of intensity I_0 enters the standard solution and the intensity I_{St} of the emerging beam is measured. A light beam of the same intensity I_0 enters the sample solution and the intensity I_{Sm} of the emerging beam is measured. See Exercise 5.5.21.

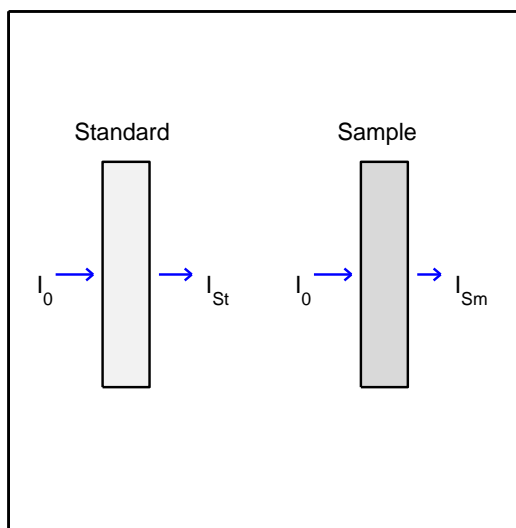

A light beam of the same intensity I_0 enters the sample solution and the intensity I_{Sm} of the emerging beam is measured.

In the mathematical model of light absorbance (the amount of light absorbed by a layer of water is proportional to the thickness of the layer and to the amount of light entering the layer), the proportionality constant K is a measure of the opacity of the water. Recall that the solution Equation 5.25 is $I(x) = I_0, e^{-Kx}$.

The bacteria in the sample placed in the spectrophotometer increase the turbidity and therefore the opacity of the solution. Explain why cell density is proportional to

$$\ln \left(\frac{I_{Sm}}{I_{St}} \right)$$

The number $\ln(I_{Sm}/I_{St})$ is called *absorbance*.

Exercise 5.5.22 A patient comes into your emergency room and you start a penicillin infusion of 0.2 gms/min into the 6 liter vascular pool. Plasma circulates through the kidney at the rate of 1.2 liters/minute and the kidneys remove 20 per cent of the penicillin that passes through.

- Draw a schematic diagram showing the vascular pool and kidneys as separate entities, an artery leading from the vascular pool to the kidney and a vein leading from the kidney back to the vascular pool.
- Let $P(t)$ be the amount of penicillin in the vascular pool t minutes after injection of penicillin. What is $P(0)$?
- Use Primitive Concept 2 to write an equation for P' .
- Compute the solution to your equation and draw the graph of P .
- The saturation level of penicillin in this problem is critically important to the correct treatment of your patient. Will it be high enough to control the infection you wish to control? If not, what should you do?
- Suppose your patient has impaired kidney function and that plasma circulates through the kidney at the rate of 0.8 liters per minute and the kidneys remove 15 percent of the penicillin that passes through. What is the saturation level of penicillin in this patient, assuming you administer penicillin the same as before?

Exercise 5.5.23 An egg is covered by a hen and is at 37°C . The hen leaves the nest and the egg is exposed to 17°C air.

- a. Draw a graph representative of the temperature of the egg t minutes after the hen leaves the nest.

Mathematical Model 5.5.6 Egg cooling. During any short time interval while the egg is uncovered, the change in egg temperature is proportional to the length of the time interval and proportional to the difference between the egg temperature and the air temperature.

- b. Let $T(t)$ denote the egg temperature t minutes after the hen leaves the nest. Consider a short time interval, $[t, t + \Delta t]$, and write an equation for the change in temperature of the egg during the time interval $[t, t + \Delta t]$.
- c. Argue that as Δt approaches zero, the terms of your previous equation get close to the terms of

$$T'(t) = -k(T(t) - 17) \quad (5.32)$$

- d. Assume $T(0) = 37$ and find an equation for $T(t)$.
- e. Suppose it is known that eight minutes after the hen leaves the nest the egg temperature is 35°C . What is k ?
- f. Based on that value of k , if the coldest temperature the embryo can tolerate is 32°C , when must the hen return to the nest?

Note: Equation 5.32 is referred to as Newton's Law of Cooling.

Exercise 5.5.24 Consider the following osmosis experiment in biology laboratory.

Material: A thistle tube, a 1 liter flask, some salt water, and some pure water, a membrane that is impermeable to the salt and is permeable to the water.

The bulb of the thistle tube is filled with salt water, the membrane is placed across the open part of the bulb, and the bulb is inverted in a beaker of pure water so that the top of the pure water is at the juncture of the bulb with the stem. See the diagram.

Because of osmotic pressure the pure water will cross the membrane pushing water up the stem of the thistle tube until the increase in pressure inside the bulb due to the water in the stem matches the osmotic pressure across the membrane.

Our problem is to describe the height of the water in the stem as a function of time.

Mathematical Model 5.5.7 Osmotic diffusion across a membrane. The rate at which pure water crosses the membrane is proportional to the osmotic pressure across the membrane minus the pressure due to the water in the stem.

Assume that the volume of the bulb is much larger than the volume of the stem so that the concentration of salt in the thistle tube may be assumed to be constant.

Introduce notation and write a derivative equation with initial condition that will describe the height of the water in the stem as a function of time. Solve your derivative equation.

Exercise 5.5.25 2 kilos of a fish poison, rotenone, are mixed into a lake which has a volume of $100 \times 20 \times 2 = 4000$ cubic meters. A stream of clean water flows into the lake at a rate of 1000 cubic meters per day. Assume that it mixes immediately throughout the whole lake. Another stream flows out of the lake at a rate of 1000 cubic meters per day.

What is the amount (p_t for discrete time or $P(t)$ for continuous time) of poison in the lake at time t days after the poison is applied?

- a. Treat the problem as a discrete time problem with one-day time intervals. Solve the difference equation

$$p_0 = 2 \quad p_{t+1} - p_t = -\frac{1000}{4000}p_t$$

- b. Let t denote continuous time and $P(t)$ the amount of poison in the lake at time t . Let $[t, t + \Delta t]$ denote a short time interval (measured in units of days). An equation for the mathematical model is

$$P(t + \Delta t) - P(t) = -\frac{P(t)}{4000} \Delta t 1000$$

Show that the units on the terms of this equation balance.

- c. Argue that

$$P(0) = 2, \quad P'(t) = -0.25 P(t)$$

- d. Compute the solution to this equation.

- e. Compare the solution to the discrete time problem, p_t , with the solution to the continuous time problem, $P(t)$.

- f. For what value of k will the solution, $Q(t)$, to

$$Q(0) = 2, \quad Q'(t) = k Q(t) \quad \text{satisfy} \quad Q(t) = p_t, \quad \text{for } t = 0, 1, 2, \dots?$$

- g. Which of $P(t)$ and $Q(t)$ most accurately estimates rotenone levels?

- h. On what day, \bar{t} will $P(\bar{t}) = 4\text{g}$?

Exercise 5.5.26 Continuous version of Chapter Exercise 1.11.7. Atmospheric pressure decreases with increasing altitude. Derive a dynamic equation from the following mathematical model, solve the dynamic equation, and use the data to evaluate the parameters of the solution equation.

Mathematical Model 5.5.8 Mathematical Model of Atmospheric Pressure. Consider a vertical column of air based at sea level and assume that the temperature within the column is constant, equal to 20°C . The pressure at any height is the weight of air in the column above that height divided by the cross sectional area of the column. In a 'short' section of the column, by the ideal gas law the mass of air within the section is proportional to the product of the volume of the section and the pressure within the section (which may be considered constant and equal to the pressure at the bottom of the section). The weight of the air above the lower height is the weight of air in the section plus the weight of air above the upper height.

Sea-level atmospheric pressure is 760 mm Hg and the pressure at 18,000 feet is one-half that at sea level.

Exercise 5.5.27 When you open a bottle containing a carbonated soft drink, CO_2 dissolved in the liquid turns to gas and escapes from the liquid. If left open and undisturbed, the drink goes flat (loses its CO_2). Write a mathematical model descriptive of release of carbon dioxide in a carbonated soft drink. From your model, write a derivative equation descriptive of the carbon dioxide content in the liquid minutes after opening the drink.

Exercise 5.5.28 *Decompression illness in deep water divers.* In the 1800's technology was developed to supply compressed air to under water divers engaged in construction of bridge supports and underwater tunnels. While at depth those divers worked without unusual physical discomfort. Shortly after ascent to the surface, however, they might experience aching joints, numbness in the limbs, fainting, and possible death. Affected divers tended to walk bent over and were said to have the "bends".

It was believed that nitrogen absorbed by the tissue at the high pressure below water was expanding during ascent to the surface and causing the difficulty, and that a diver who ascended slowly would be at less risk. The British Navy commissioned physician and mathematician J. S. Haldane¹¹ to devise a dive protocol to be followed by Navy divers to reduce the risk of decompression illness. Nitrogen flows quickly between the lungs and the plasma but nitrogen exchange between the plasma and other parts of the body (nerve, brain tissue, muscle, fat, joints, liver, bone marrow, for example) is slower and not uniform. Haldane used a simple model for nitrogen exchange between the plasma and the other parts of the body.

Mathematical Model 5.5.9 Nitrogen absorption and release in tissue. The rate at which nitrogen is absorbed by a tissue is proportional to the difference in the partial pressure of nitrogen in the plasma and the partial pressure of nitrogen in the tissue.

Air is 79 percent nitrogen. Assume that the partial pressure of nitrogen in the lungs and the plasma are equal at any depth. At depth d ,

$$\text{Plasma pp N}_2 = \text{Lung pp N}_2 = 0.79 \left(1 + \frac{d}{10} \right) \text{ atmospheres.}$$

- What is the partial pressure of nitrogen in a diver's lungs at the surface?
- Suppose a diver has not dived for a week. What would you expect to be the partial pressure of nitrogen in her tissue?
- A diver who has not dived for a week quickly descends to 30 meters. What is the nitrogen partial pressure in her lungs after descending to 30 meters?
- Let $N(t)$ be the partial pressure of nitrogen in a tissue of volume, V , t minutes into the dive. Use the Mathematical Model 5.5.9 Nitrogen absorption and release in tissue and Primitive Concept 2, to write an equation for N' .
- Check to see whether (k is a proportionality constant)

$$N(t) = 0.79 \left(1 + \frac{d}{10} \right) - 0.79 \frac{d}{10} e^{-\frac{k}{V}t} \quad (5.33)$$

solves your equation from the previous step.

¹¹J. S. Haldane was the father of J. B. S. Haldane who, along with R. A. Fisher and Sewall Wright developed the field of population genetics.

- f. Assume $\frac{k}{V}$ in Equation 5.33 is 0.0693 and $d = 30$. What is $N(30)$?
- g. Haldane experimented on goats and concluded that on the ascent to the surface, $N(t)$ should never exceed two times Lung pp N_2 . A diver who had been at depth 30 meters for 30 minutes could ascend to what level and not violate this condition if $\frac{k}{V} = 0.0693$?

Haldane supposed that there were five tissues in the body for which $\frac{k}{V} = 0.139, 0.0693, 0.0347, 0.0173, 0.00924$, respectively, and advised that on ascent to the surface, $N(t)$ should never exceed two times pp N_2 in any one of these tissues.

Exercise 5.5.29 E. O. Wilson, a pioneer in study of area-species relations on islands, states in *Diversity of Life*, p 221, :

“In more exact language, the number of species increases by the area-species equation, $S = C A^z$, where A is the area and S is the number of species. C is a constant and z is a second, biologically interesting constant that depends on the group of organisms (birds, reptiles, grasses). The value of z also depends on whether the archipelago is close to source areas, as in the case of the Indonesian islands, or very remote, as with Hawaii . . . It ranges among faunas and floras around the world from about 0.15 to 0.35.”

Discuss this statement as a potential Mathematical Model.

Exercise 5.5.30 The graph of Figure 5.5.30 showing the number of amphibian and reptile species on Caribbean Islands *vs* the areas of the islands is a classic example from P. J. Darlington, *Zoogeography: The Geographical Distribution of Animals*, Wiley, 1957, page 483, Tables 15 and 16.

- Treat Trinidad as an unexplained outlier (meaning: ignore Trinidad) and find a power law, $S = C A^z$, relating number of species to area for this data.
- Darlington observes that “. . . within the size range of these islands . . ., division of the area by ten divides the amphibian and reptile fauna by two . . ., but this ratio is a very rough approximation, and it might not hold in other situations.” Is your power law consistent with Darlington’s observation?
- Why might Trinidad (4800 km²) have nearly twice as many reptilian species (80) as Puerto Rico (8700 km²) which has 41 species?

Figure for Exercise 5.5.30 The number of amphibian and reptile species on islands in the Caribbean *vs* the areas of the islands. The data is from Tables 15 and 16 in P. J. Darlington, *Zoogeography: The Geographical Distribution of Animals*, Wiley, 1957, page 483.

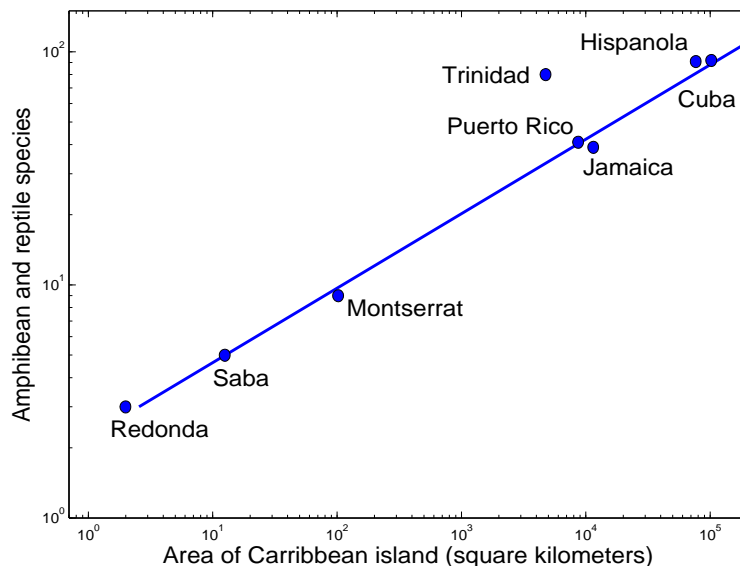

Exercise 5.5.31 The graph in Figure Ex. 5.5.31 relates surface area to mass of a number of mammals. Assume mammal population densities are constant (each two mammal populations are equally dense), so that the graph also relates surface area to volume.

- Find an equation relating the surface area, S , of a cube to the volume, V , of the cube.
- Find an equation relating the surface area, $S = 4\pi r^2$, of a sphere of radius r to the volume, $V = \frac{4}{3}\pi r^3$, of the sphere.
- Find an equation relating the surface area of a mammal to the mass of the mammal, using the graph in Figure Ex. 5.5.31. Ignore the dark dots; they are for beech trees.
- In what way are the results for the first three parts of this exercise similar?

Figure for Exercise 5.5.31 Graph for Exercise 5.5.31 relating surface area to mass of mammals. From A. M. Hemmingson, Energy metabolism as related to body size, and its evolution, Rep. Steno Mem. Hosp. (Copenhagen) 9:1-110. With permission from Dr. Peter R. Rossing, Director of Research, Steno Diabetes Center S/A. All rights reserved.

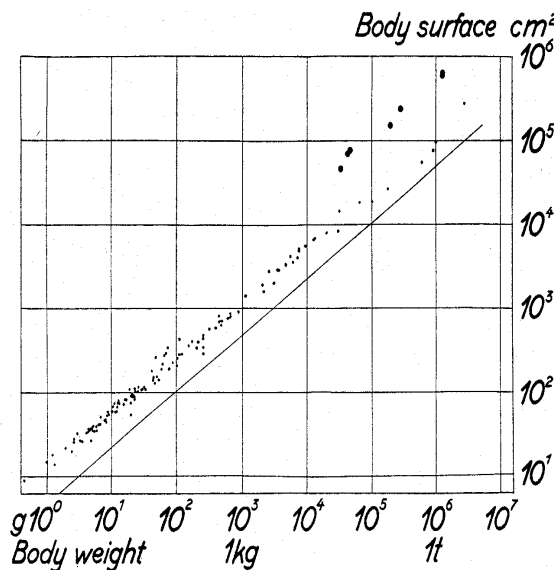

Exercise 5.5.32 Body Mass Indices. The Body Mass Index,

$$\text{BMI} = \frac{\text{Mass}}{\text{Height}^2}$$

was introduced by Adolphe Quetelet, a French mathematician and statistician in 1869. The Center for Disease Control and Prevention (CDC) notes that BMI is a helpful indicator of overweight and obesity in adults.

From simple allometric considerations, $\text{BMI3} = \text{Mass}/\text{Height}^3$ should be approximately a constant, C . If

$$\text{BMI3} = \text{Mass}/\text{Height}^3 = C \quad \text{then} \quad \text{BMI} = \text{Mass}/\text{Height}^2 = C \text{ Height.}$$

so that BMI should increase with height. CDC also states that “... women are more likely to have a higher percentage of body fat than men for the same BMI.” If a male and a female both have $\text{BMI} = 23$ and are of average height for their sex (1.77 meters for males and 1.63 meters for females), then

$$\text{BMI3 for the male} = \frac{23}{1.77} = 13.0 \quad \text{and} \quad \text{BMI3 for the female} = \frac{23}{1.63} = 14.1$$

Thus BMI3 is larger for the female than for the male and may indicate a larger percentage of body fat for the female.

Shown are four Age, and 50th percentile Weight, Height data points for boys and for girls. Compute BMI and BMI3 for the four points and plot the sixteen points on a graph. Which of the two indices, BMI or BMI3, remains relatively constant with age? Data are from the Centers for Disease Control and Prevention, <http://www.cdc.gov/growthcharts/data/set1clinical/cj41c021.pdf> and ... cj41c022.pdf.

Age (Boys)	8	12	16	20
Weight (kg) (50 percentile)	26	41	62	71
Height (cm) (50 percentile)	128	149	174	177
BMI kg/m^2				
BMI3 kg/m^3				
Age (Girls)	8	12	16	20
Weight (kg) (50 percentile)	26	41	54	58
Height (cm) (50 percentile)	128	151	162	163
BMI kg/m^2				
BMI3 kg/m^3				

We suggest that BMI3 might be more useful than BMI as an index of body fat. Other indices of body fat that have been suggested include M/H , $M^{1/3}/H$, $H/M^{1/3}$, and $cM^{1.2}/H^{3.3}$. The interested reader should visit the web site cdc.gov/nccdphp/dnpa/bmi and read the references there.

5.6 Exponential and logarithm chain rules.

Suppose an function $u(t)$ has a derivative for all t . Then

$$\left[e^{u(t)} \right]' = e^{u(t)} u'(t) \quad \text{Exponential Chain Rule.} \quad (5.34)$$

The Exponential Chain Rule is used to prove

$$[\ln t]' = \frac{1}{t}, \quad \text{for } t > 0 \quad \text{Logarithm Rule.} \quad (5.35)$$

and, assuming u is positive,

$$[\ln u(t)]' = \frac{1}{u(t)} u'(t) \quad \text{Logarithm Chain Rule.} \quad (5.36)$$

Recall Theorem 4.2.1, The Derivative Requires Continuity. If $u(t)$ is a function and $u'(t)$ exists at $t = a$

$$\lim_{b \rightarrow a} u(b) = u(a)$$

Proof of the exponential chain rule. We prove the rule for the case the u is an increasing function.

Suppose $u(t)$ has a derivative at $t = a$ and $E(t) = e^{u(t)}$. To simplify the argument we assume that $u(t)$ is increasing. That is, if $a < b$, then $u(a) < u(b)$, and, in particular, $u(b) - u(a) \neq 0$.

Then

$$\begin{aligned} E'(a) &= \lim_{b \rightarrow a} \frac{e^{u(b)} - e^{u(a)}}{b - a} = \lim_{b \rightarrow a} \frac{e^{u(b)} - e^{u(a)}}{u(b) - u(a)} \frac{u(b) - u(a)}{b - a} \\ &= \lim_{b \rightarrow a} \frac{e^{u(b)} - e^{u(a)}}{u(b) - u(a)} \times \lim_{b \rightarrow a} \frac{u(b) - u(a)}{b - a} = e^{u(a)} \times u'(a) \end{aligned}$$

End of Proof.

The limit

$$\lim_{b \rightarrow a} \frac{e^{u(b)} - e^{u(a)}}{u(b) - u(a)} = e^{u(a)}$$

requires some explanation. The graph of $y = e^x$ is shown in Figure 5.9. At every point, (x, e^x) of the graph, the slope of the tangent is e^x , and specifically at the point $(u(a), e^{u(a)})$ the slope is $m = e^{u(a)}$. The difference quotient

$$\frac{e^{u(b)} - e^{u(a)}}{u(b) - u(a)}$$

is the slope of a secant to the graph. Because $\lim_{b \rightarrow a} u(b) = u(a)$ the slope of the secant approaches the slope of the tangent. Thus

$$\lim_{b \rightarrow a} \frac{e^{u(b)} - e^{u(a)}}{u(b) - u(a)} = e^{u(a)}.$$

Example 5.6.1 Find the derivatives of

$$P(x) = 200e^{-3x} \qquad Q(x) = \frac{1}{\sqrt{2\pi}} e^{-x^2/2}$$

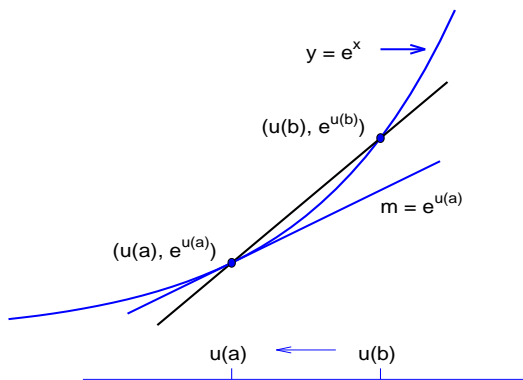

Figure 5.9: Graph of $y = e^x$. Because $u'(a)$ exists, $u(b) \rightarrow u(a)$ as $b \rightarrow a$. Therefore the slope of the secant, $\frac{u(b)-u(a)}{b-a}$, approaches the slope of the tangent, $e^{u(a)}$.

Solutions:

$$\begin{aligned}
 P'(x) &= [200 e^{-3x}]' & Q'(x) &= \left[\frac{1}{\sqrt{2\pi}} e^{-x^2/2} \right]' && \text{Logical Identity} \\
 &= 200 [e^{-3x}]' & &= \frac{1}{\sqrt{2\pi}} [e^{-x^2/2}]' && \text{Constant Factor Rule} \\
 &= 200 e^{-3x} [-3x]' & &= \frac{1}{\sqrt{2\pi}} e^{-x^2/2} [-x^2/2]' && \text{Exponential Chain Rule} \\
 &= 200 e^{-3x} (-3) & &= \frac{1}{\sqrt{2\pi}} e^{-x^2/2} (-x) && \text{Constant Factor, Power Rules}
 \end{aligned}$$

The derivative of $P(x) = 200 e^{-3x}$ also can be computed using the e^{kt} Rule. The e^{kt} rule is a special case of the exponential chain rule:

$$[e^{kt}]' = e^{kt} [kt]' = e^{kt} k.$$

The derivative of $L(t) = \ln t$. The exponential chain rule 5.34 is used to derive the natural logarithm rule, Equation 5.35. In order to use the formula $[e^{u(t)}]' = e^{u(t)} u'(t)$ it is necessary to know that $u'(t)$ exists. We want to compute $[e^{\ln t}]'$ and need to know that $[\ln t]'$ exists. Our argument for this is shown in Figure 5.10. Also observe that L is increasing so that our argument for the exponential chain rule which assumed that $u(t)$ was increasing is sufficient for this use. Knowing that $[\ln t]'$ exists, it is easy to obtain a formula for it.

$$\left. \begin{aligned}
 e^{\ln t} &= t && (i) \\
 [e^{\ln t}]' &= [t]' && (ii) \\
 e^{\ln t} [\ln t]' &= 1 && (iii) \\
 t [\ln t]' &= 1 && (iv) \\
 [\ln t]' &= \frac{1}{t} && \text{Algebra}
 \end{aligned} \right\} \tag{5.37}$$

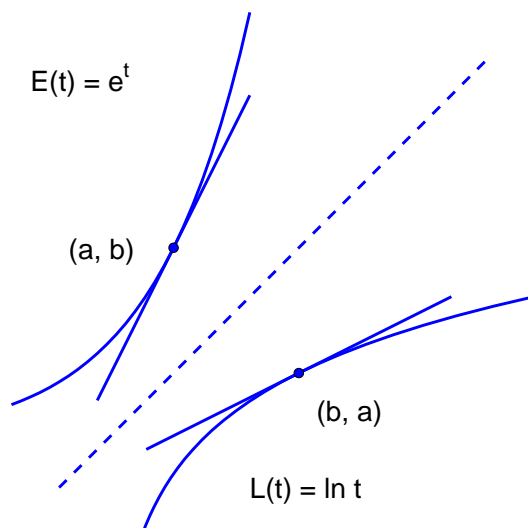

Figure 5.10: Graphs of $E(t) = e^t$ and $L(t) = \ln t$ and tangents at corresponding points. Because L is the inverse of E , the graph of L is the reflection of the graph of E about the line $y = x$. Because E has a tangent at (a, b) (that is not horizontal! actually with positive slope), L has a tangent at (b, a) (with positive slope). Therefore $L'(b)$ exists for every positive value of b .

We have now proved the natural logarithm rule, another Primary Formula:

Natural Logarithm Rule

$$[\ln t]' = \frac{1}{t} \tag{5.38}$$

Using the natural logarithm rule and some properties of logarithms we can differentiate $y(t) = \ln 5t + \ln t^3$:

$$\begin{aligned}
 y'(t) &= [\ln 5t + \ln t^3]' && \text{Symbolic identity} \\
 &= [\ln 5 + \ln t + 3 \ln t]' && \text{Logarithm Prop's} \\
 &= [\ln 5]' + [\ln t]' + [3 \ln t]' && \text{Sum Rule} \\
 &= 0 + [\ln t]' + [3 \ln t]' && \text{Constant Rule} \\
 &= 0 + [\ln t]' + 3 [\ln t]' && \text{Constant Factor Rule} \\
 &= 0 + \frac{1}{t} + 3 \frac{1}{t} && \text{Natural Logarithm Rule} \\
 &= 4 \frac{1}{t}
 \end{aligned}$$

Example 5.6.2 Logarithm functions to other bases have derivatives, but not as neat as $1/t$. We compute $L'(t)$ for $L(t) = \log_b t$ where $b > 0$ and $b \neq 1$.

Solution.

$$\begin{aligned} [\log_b t]' &= \left[\frac{\ln t}{\ln b} \right]' && (i) \\ &= \frac{1}{\ln b} [\ln t]' && (ii) \\ &= \frac{1}{\ln b} \frac{1}{t} && (iii) \end{aligned} \tag{5.39}$$

We summarize this as

$$[\log_b t]' = \frac{1}{\ln b} \frac{1}{t} \tag{5.40}$$

The Logarithm Chain Rule. We now use the Exponential Chain Rule 5.34 to show that if $u(t)$ is a positive increasing function and $u'(t)$ and $[\ln u(t)]'$ exist for all t , then

$$[\ln u(t)]' = \frac{1}{u(t)} [u(t)]'$$

Proof. By the Exponential Chain Rule and $e^{\ln u(t)} = u(t)$,

$$[e^{\ln u(t)}]' = [u(t)]'$$

$$e^{\ln u(t)} [\ln u(t)]' = u'(t)$$

$$[\ln u(t)]' = \frac{1}{u(t)} u'(t)$$

This is the

Logarithm Chain Rule

$$[\ln u(t)]' = \frac{1}{u(t)} u'(t) \tag{5.41}$$

Example 5.6.3 Find the derivatives of

$$\text{a. } y = \ln(\sqrt{1-t^2}) \qquad \text{b. } y = \ln\left(\frac{1-t}{1+t}\right)$$

Solutions:

$$\begin{aligned}
\left[\ln(\sqrt{1-t^2}) \right]' &= \left[\frac{1}{2} \ln(1-t^2) \right]' && \text{Logarithm Property} \\
&= \frac{1}{2} [\ln(1-t^2)]' && \text{Constant Factor} \\
&= \frac{1}{2} \frac{1}{1-t^2} [(1-t^2)]' && \text{Generalized Logarithm Rule} \\
&= \frac{1}{2} \frac{1}{1-t^2} (-2t) && \text{Sum, Constant, Constant Factor, and Power Rules}
\end{aligned}$$

$$\begin{aligned}
\text{b. } \left[\ln\left(\frac{1-t}{1+t}\right) \right]' &= [\ln(1-t) - \ln(1+t)]' && \text{Logarithm Property} \\
&= [\ln(1-t)]' - [\ln(1+t)]' && \text{Sum Rule} \\
&= \frac{1}{1-t} [1-t]' - \frac{1}{1+t} [1+t]' && \text{Generalized Logarithm Rule} \\
&= \frac{1}{1-t} (-1) - \frac{1}{1+t} (1) && \text{Sum, Constant, and Power Rules} \\
&= \frac{-2}{1-t^2} && \text{Algebra} \quad \blacksquare
\end{aligned}$$

Example 5.6.4 *Logarithmic Differentiation.* Suppose we are to differentiate

$$y(t) = (t+2)(t+1)(t-1)$$

Proceeding indirectly, we first compute the derivative of the natural logarithm of y .

$$\begin{aligned}
\ln(y(t)) &= \ln((t+2)(t+1)(t-1)) && \text{Logical Identity} \\
\ln(y(t)) &= \ln(t+2) + \ln(t+1) + \ln(t-1) && \text{Logarithm Property} \\
[\ln(y(t))] &= [\ln(t+2) + \ln(t+1) + \ln(t-1)] && \text{Logical Identity.} \\
\frac{1}{y(t)} y'(t) &= \frac{1}{t+2} [t+2]' + \frac{1}{t+1} [t+1]' + \frac{1}{t-1} [t-1]' && \text{Logarithm chain rule.} \\
y'(t) &= y(t) \left(\frac{1}{t+2} + \frac{1}{t+1} + \frac{1}{t-1} \right) && [t+C]' = 1. \\
y'(t) &= (t+2)(t+1)(t-1) \left(\frac{1}{t+2} + \frac{1}{t+1} + \frac{1}{t-1} \right) && \text{Definition of } y. \\
y'(t) &= (t+1)(t-1) + (t+2)(t-1) + (t+2)(t+1) && \text{Algebra.} \quad \blacksquare
\end{aligned}$$

Exercises for Section 5.6, The exponential chain rule and the logarithm chain rule.

Exercise 5.6.1 Use one rule for each step and identify the rule to differentiate

$$\begin{array}{ll} \text{a. } P(t) = 3 \ln t + e^{3t} & \text{b. } P(t) = t^2 + \ln 2t \\ \text{c. } P(t) = \ln 5 & \text{d. } P(t) = \ln(e^{2t}) \\ \text{e. } P(t) = \ln(t^2 + t) & \text{f. } P(t) = e^{t^2-t} \\ \text{g. } P(t) = e^{1/x} & \text{h. } P(t) = e^{\sqrt{x}} \\ \text{i. } P(t) = \ln((t+1)^2) & \text{j. } P(t) = e^{-t^2/2} \end{array}$$

Exercise 5.6.2 Compute the derivatives of

$$\begin{array}{lll} \text{a. } P(t) = e^{(t^2)} & \text{b. } P(t) = \ln(t^2) & \text{c. } P(t) = (e^t)^2 \\ \text{d. } P(t) = e^{(2 \ln t)} & \text{e. } P(t) = \ln(e^{3t}) & \text{f. } P(t) = \sqrt{e^t} \\ \text{g. } P(t) = e^5 & \text{h. } P(t) = \ln(\sqrt{t}) & \text{i. } P(t) = e^{t+1} \end{array}$$

Exercise 5.6.3 Supply reasons that justify the steps (i) – (iv) in the equations 5.37.

Exercise 5.6.4 Give reasons for the steps (i) – (iii) in Equation 5.39 deriving the derivative of the logarithm function $L(t) = \log_b t$.

Exercise 5.6.5 Find a value for x for which $P'(x) = 0$.

$$\text{a. } P(t) = xe^{-x} \quad \text{b. } P(t) = e^{-x} - e^{-2x} \quad \text{c. } P(t) = x^2e^{-x}$$

Exercise 5.6.6 Use the logarithm chain rule to prove that for all numbers, n :

$$\text{Power chain rule for all } n \quad [(u(t))^n]' = n(u(t))^{n-1} u'(t)$$

Assume that u is a positive increasing function and $u'(t)$ exists.

Exercise 5.6.7 Use the logarithmic differentiation to compute $y'(t)$ for

$$\begin{array}{lll} \text{a. } y(t) = t^\pi & \text{b. } y(t) = t^e & \text{c. } y(t) = (1+t^2)^\pi \\ \text{d. } y(t) = t^3 e^t & \text{e. } y(t) = e^{\sin t} & \text{f. } y(t) = t^t \end{array}$$

Exercise 5.6.8 Use the logarithmic differentiation to compute $y'(t)$ for

$$\begin{array}{lll} \text{a. } y(t) = \frac{(t-1)(t+1)}{t-2} & \text{b. } y(t) = te^t & \text{c. } y(t) = e^{-\frac{t^2}{2}} \\ \text{d. } y(t) = \sqrt{1+t^2} & \text{e. } y(t) = \frac{t^2}{t^2+1} & \text{f. } y(t) = 2^t \\ \text{g. } y(t) = b^t \quad b > 0 & \text{h. } y(t) = \frac{e^t - e^{-t}}{e^t + e^{-t}} & \text{i. } y(t) = \frac{\ln t}{e^t} \end{array}$$

5.7 Summary.

The remarkable number e , the exponential function $E(t) = e^t$, and the natural logarithm function $L(t) = \ln t$ are the basic material for this chapter. The number e is defined by

$$\lim_{c \rightarrow 0} (1 + c)^{\frac{1}{c}} = e$$

It is the only number, b , for which

$$\lim_{h \rightarrow 0} \frac{b^h - 1}{h} = 1$$

Because $\lim_{h \rightarrow 0} (e^h - 1)/h = 1$, the function $E(t) = e^t$ has the property that $E'(t) = e^t$. For any other base, $b > 0$, the exponential function $B(t) = b^t$ has a derivative, but $B'(t) = b^t \ln b$ has the extra factor $\ln b$. The natural logarithm function, $L(t) = \log_e t = \ln t$ also has a simple derivative, $1/t$, and its derivative is the simplest among all logarithm functions. For $L(t) = \log_b t$, $L'(t) = (1/t)/(\ln b)$.

The function $E(t) = e^{kt}$ has the property

$$E'(t) = e^{kt} k = k E(t)$$

Many mathematical models of biological and physical systems yield equations of the form $y'(t) = k y(t)$, and for that reason we frequently use the exponential function e^{kt} to describe natural phenomena.

When analyzing data thought to be exponential, a semilog graph of the data will often signal whether the data is indeed exponential.

The exponential and logarithm chain rules

$$\left[e^{u(t)} \right]' = e^{u(t)} u'(t) \quad \left[\ln(u(t)) \right]' = \frac{1}{u(t)} u'(t)$$

expand the class of functions for which we can compute derivatives, and the logarithm chain rule is used to extend the power chain rule for integer exponents to all values of the exponent.

Exercises for the Summary of Chapter 5.

Chapter Exercise 5.7.1 Compute $P'(t)$ for:

- | | | |
|---------------------------|------------------------------|----------------------------|
| a. $P(t) = e^{5t}$ | b. $P(t) = \ln 5t$ | c. $P(t) = e^{t\sqrt{t}}$ |
| d. $P(t) = e^{\sqrt{2t}}$ | e. $P(t) = \ln(\ln t)$ | f. $P(t) = e^{\ln t}$ |
| g. $P(t) = 1/(1 + e^t)$ | h. $P(t) = 1/\ln t$ | i. $P(t) = 1/(1 + e^{-t})$ |
| j. $P(t) = (1 + e^t)^3$ | k. $P(t) = (e^{\sqrt{t}})^3$ | l. $P(t) = \ln \sqrt{t}$ |

Chapter Exercise 5.7.2 Use the logarithmic differentiation to compute $y'(t)$ for

- | | |
|----------------------------|-----------------------------|
| a. $y(t) = 10^t$ | b. $y(t) = \frac{t-1}{t+1}$ |
| c. $y(t) = (t-1)^3(t^3-1)$ | d. $y(t) = (t-1)(t-2)(t-3)$ |
| e. $y(t) = u(t)v(t)w(t)$ | f. $y(t) = u(t)v(t)$ |

Chapter Exercise 5.7.3 Use a semilog graph to determine which of the following data sets are exponential.

a.

t	P(t)
0	5.00
1	3.53
2	2.50
3	1.77
4	1.25
5	0.88

b.

t	P(t)
0	5.00
1	1.67
2	1.00
3	0.71
4	0.55
5	0.45

c.

t	P(t)
0	5.00
1	3.63
2	2.50
3	1.63
4	1.00
5	0.63

Chapter Exercise 5.7.4 The function

$$P(t) = \frac{10 e^t}{9 + e^t} = \frac{10}{9 e^{-t} + 1}$$

is an example of a logistic function. The logistic functions are often used to describe the growth of populations. Plot the graphs of $P(t)$ and $P'(t)$. Find at time at which P' is a maximum. Identify the point on the graph of P corresponding to that time.

Chapter Exercise 5.7.5 A pristine lake of volume 1,000,000 m³ has a river flowing through it at a rate of 10,000 m³ per day. A city built beside the river begins dumping 1000 kg of solid waste into the river per day.

1. Write a derivative equation that describes the amount of solid waste in the lake t days after dumping begins.
2. What will be the concentration of solid waste in the lake after one year?

Chapter Exercise 5.7.6 Estimate the slope of the tangent to the graph of

$$y = \log_{10} x$$

at the point $(3, \log_{10} 3)$ correct to three decimal digits.

Chapter Exercise 5.7.7 Use logarithmic differentiation to show that $y = te^{3t}$ satisfies $y'' - 6y' + 9y = 0$.

Chapter Exercise 5.7.8 Show that for any numbers C_1 and C_2 , $y = C_1 e^t + C_2 e^{-t}$ satisfies $y'' - y = 0$.

Chapter 6

Derivatives of Products, Quotients and Compositions of Functions.

Where are we going?

The basic derivative formulas that you need are shown below. Many additional derivative formulas are derived from them.

The trigonometric derivatives are developed in Chapter 7. The last three Combination Rules are developed in this chapter.

Primary Formulas

$$[C]' = 0$$

$$[t^n]' = nt^{n-1}$$

$$[e^t]' = e^t$$

$$[\ln t]' = \frac{1}{t}$$

$$[\sin t]' = \cos t$$

$$[\cos t]' = -\sin t$$

(6.1)

Combination formulas

$$[u + v]' = [u]' + [v]'$$

$$[Cu]' = C [u]'$$

$$[uv]' = [u]' v + u [v]'$$

$$\left[\frac{u}{v}\right]' = \frac{v [u]' - u [v]'}{v^2}$$

$$[G(u)]' = G'(u) u'$$

6.1 Derivatives of Products and Quotients.

Derivatives of products. We determine the derivative of a function, P , that is a product of two functions, $P(t) = u(t) \times v(t)$ in terms of the values of $u(t)$, $u'(t)$, $v(t)$ and $v'(t)$; all four are

required. The formula we obtain is

$$[u(t) \times v(t)]' = u'(t) \times v(t) + u(t) \times v'(t) \quad (6.2)$$

It is not a very intuitive formula. The derivative of a sum of two functions is the sum of the derivatives of the functions. One might expect derivative of the product of two functions to be the product of the derivatives of the two functions. Alas, this is seldom correct, but were it correct your learning of calculus would be notably simplified.

The correct formula is used as follows. Let

$$P(t) = t^3 \times e^{-2t}$$

Then with $u(t) = t^3$ and $v(t) = e^{-2t}$,

$$\begin{aligned} P'(t) &= [t^3]' \times e^{-2t} + t^3 \times [e^{-2t}]' \\ &= 3t^2 \times e^{-2t} + t^3 \times e^{-2t} \times (-2) \end{aligned}$$

A product of functions is useful, for example, in examining the factors affecting total corn production. Total production, $P(t)$, is the product of the number of acres planted, $A(t)$, and the average yield per acre, $Y(t)$. The factors that affect $A(t)$ and $Y(t)$ are distinct. The acres planted, $A(t)$, is affected mostly by government programs and anticipated price of corn; the yield, $Y(t)$, is affected mostly by natural events such as weather and insect prevalence and by improved genetics and farming practices. Government economists often try to maintain total production, $P(t)$, at a fairly constant level, but can affect only $A(t)$, the number of acres planted.

Other instances in which a function is inherently a product of component parts include

1. In simple epidemiological models, the number of newly infected is proportional to the product of the number of infected and the number of susceptible.
2. The rate of a binary chemical reaction $A + B \longrightarrow AB$ is usually proportional to the product of the concentrations of the two constituents of the reaction.

We prove the following theorem:

Theorem 6.1.1 *Suppose u and v are two functions. Then for every number a for which $u'(a)$ and $v'(a)$ exist,*

$$[u(t) \times v(t)]'_{t=a} = u'(a) \times v(a) + u(a) \times v'(a) \quad (6.3)$$

The proof uses Theorem 4.2.1, The Derivative Requires Continuity, which in symbols is:

$$\lim_{b \rightarrow a} \frac{u(b) - u(a)}{b - a} = u'(a) \quad \text{exists implies that} \quad \lim_{b \rightarrow a} u(b) = u(a).$$

Proof of Theorem 6.1.1.

$$\begin{aligned}
 [u(t) \times v(t)]'_{t=a} &= \lim_{b \rightarrow a} \frac{u(b) \times v(b) - u(a) \times v(a)}{b - a} && (i) \\
 &= \lim_{b \rightarrow a} \frac{u(b) \times v(b) - u(a) \times v(b) + u(a) \times v(b) - u(a) \times v(a)}{b - a} && (ii) \\
 &= \lim_{b \rightarrow a} \left(\frac{u(b) - u(a)}{b - a} \times v(b) + u(a) \times \frac{v(b) - v(a)}{b - a} \right) && (iii) \\
 &= \lim_{b \rightarrow a} \left(\frac{u(b) - u(a)}{b - a} \times v(b) \right) + u(a) \times \lim_{b \rightarrow a} \frac{v(b) - v(a)}{b - a} && (iv) \\
 &= \lim_{b \rightarrow a} \frac{u(b) - u(a)}{b - a} \times v(a) + u(a) \times \lim_{b \rightarrow a} \frac{v(b) - v(a)}{b - a} && (v) \\
 &= u'(a) \times v(a) + u(a) \times v'(a) && (vi)
 \end{aligned} \tag{6.4}$$

End of proof.

Explore 6.1.1 In which step of Equations 6.4 was Theorem 4.2.1, The Derivative Requires Continuity, used? ■

Derivatives of quotients. The $\tan x = \frac{\sin x}{\cos x}$ is the quotient of two functions, $\sin x$ and $\cos x$. The logistic function, $L(x) = \frac{10e^x}{9+e^x}$, used to describe population growth and chemical reactions is the quotient of two exponential functions. There is a formula for computing the rate of change of quotients:

Theorem 6.1.2 Suppose u and v are functions and $u'(a)$ and $v'(a)$ exist and $v(a) \neq 0$. Then

$$\left[\frac{u(t)}{v(t)} \right]'_{t=a} = \frac{u'(a) \times v(a) - u(a) \times v'(a)}{v^2(a)} \tag{6.5}$$

UGH! Talk about nonintuitive!

Note: $v^2(a)$ is $(v(a))^2$.

Proof of Theorem 6.1.2.

$$\begin{aligned}
 \left[\frac{u(t)}{v(t)} \right]'_{t=a} &= \lim_{b \rightarrow a} \frac{\frac{u(b)}{v(b)} - \frac{u(a)}{v(a)}}{b - a} && (i) \\
 &= \lim_{b \rightarrow a} \frac{\frac{u(b)v(a) - u(a)v(b)}{b - a}}{v(b)v(a)} && (ii) \\
 &= \lim_{b \rightarrow a} \frac{\frac{u(b)v(a) - u(a)v(a) + u(a)v(a) - u(a)v(b)}{b - a}}{v(b)v(a)} && (iii) \\
 &= \lim_{b \rightarrow a} \frac{\frac{u(b) - u(a)}{b - a}v(a) - u(a)\frac{v(b) - v(a)}{b - a}}{v(b)v(a)} && (iv) \\
 &= \frac{\left(\lim_{b \rightarrow a} \frac{u(b) - u(a)}{b - a} \right) v(a) - u(a) \lim_{b \rightarrow a} \frac{v(b) - v(a)}{b - a}}{\left(\lim_{b \rightarrow a} v(b) \right) v(a)} && (v) \\
 &= \frac{u'(a) \times v(a) - u(a) \times v'(a)}{v(a)v(a)} && (vi)
 \end{aligned} \tag{6.6}$$

End of proof.

Explore 6.1.2 Was Theorem 4.2.1, The Derivative Requires Continuity, used in Equations 6.6? ■

Example 6.1.1 The logistic function and its derivative. The logistic function

$$P(t) = \frac{P_0 M e^{rt}}{M - P_0 + P_0 e^{rt}} \tag{6.7}$$

describes the size of a population of initial size P_0 and low density relative growth rate r growing in an environment with limited carrying capacity M . After the function e^{kt} , the logistic function is the most important function in population biology. The graph of a typical logistic curve is shown in Figure 6.1. Obviously, population growth rate, $P'(t)$, is important, and we use the quotient rule to compute it.

$$\begin{aligned}
 P'(t) &= \left[\frac{P_0 M e^{rt}}{M - P_0 + P_0 e^{rt}} \right]' && (i) \\
 &= P_0 M \left[\frac{e^{rt}}{M - P_0 + P_0 e^{rt}} \right]' && (ii) \\
 &= P_0 M \frac{(M - P_0 + P_0 e^{rt}) [e^{rt}]' - e^{rt} [M - P_0 + P_0 e^{rt}]'}{(M - P_0 + P_0 e^{rt})^2} && (iii) \\
 &= P_0 M \frac{(M - P_0 + P_0 e^{rt}) e^{rt} \times r - e^{rt} (0 + P_0 e^{rt} \times r)}{(M - P_0 + P_0 e^{rt})^2} && (iv) \\
 &= P_0 M \frac{(M - P_0) e^{rt} r}{(M - P_0 + P_0 e^{rt})^2} && (v) \\
 &= r \frac{P_0 M e^{rt}}{M - P_0 + P_0 e^{rt}} \frac{(M - P_0)}{M - P_0 + P_0 e^{rt}} && (vi) \\
 &= r P(t) \left(1 - \frac{P(t)}{M} \right) && (vii)
 \end{aligned} \tag{6.8}$$

Step (v) shows P' . Steps (vi) and (vii) characterize the population growth rate as

$$P'(t) = rP(t) \left(1 - \frac{P(t)}{M} \right) \tag{6.9}$$

The fraction $P(t)/M$ is the *density* of the population. If the density is small (population size, $P(t)$, is small compared to the environmental carrying capacity, M), the factor $1 - P(t)/M$ is close to 1 and ‘almost’ $P'(t) = r P(t)$. Almost $P'(t)/P(t) = r$ and for that reason r is called the *low density relative growth rate* of P . We compare $P(t)$ with the function $p(t)$ which satisfies the simpler equation

$$p(0) = P_0, \quad p'(t) = r p(t)$$

We know from Section 5.5 that

$$p(t) = P_0 e^{rt}$$

The graph of $p(t)$ is shown as the dashed curve in Figure 6.1 where it is seen that $p(t)$ is close to $P(t)$ while $P(t)$ is small.

The number $M - P(t)$ is the unused environment, or the *residual environmental capacity*. When $P(t)$ is almost as large as M (the density is large), the residual capacity $M - P(t)$ is close to zero and the factor $(1 - P(t)/M)$ is close to zero. From Equation 6.9 the growth rate of the population $P'(t)$ is also close to zero. Equation 6.9 is consistent with:

Mathematical Model 6.1.1 Mathematical model of logistic growth. The growth rate of a population is proportional to the size of the population and is proportional to the residual capacity of the environment in which the population is growing.

We acknowledge that we have reversed the usual role of modeling. We began with a reported solution equation, obtained a derivative equation, and then wrote the model. The steps are reversed with respect to the accepted order in Chapter 1, and with respect to Pierre Verhulst’s development of the model in 1838. The equation is developed in ‘proper’ order in Chapter 17 from Verhulst’s

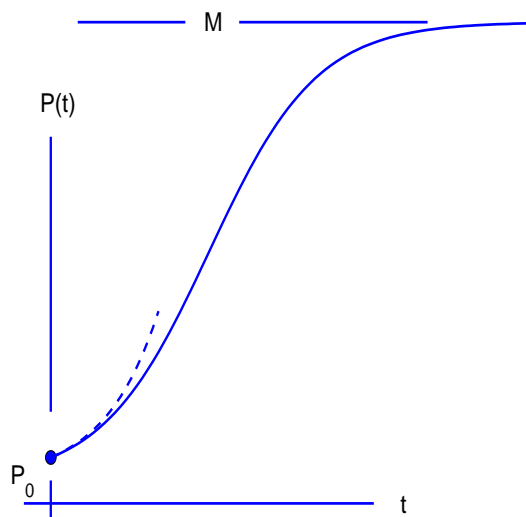

Figure 6.1: The graph of a logistic curve $P(t) = P_0 M e^{rt} / (M - P_0 + P_0 e^{rt})$. The dashed curve is the graph of $p(t) = P_0 e^{rt}$ showing the close approximation to exponential growth for $P(t)/M$ small (low density).

Mathematical Model of population growth in a limited environment The growth rate of a population is proportional to the size of the population and to the fraction of the carrying capacity unused by the population.

Example 6.1.2 Examples of computing the derivatives of products and quotients.

$$\begin{aligned}
 \text{a. } P(t) &= e^{2t} \ln t & P'(t) &= [e^{2t} \ln t]' \\
 & & &= [e^{2t}]' \ln t + e^{2t} [\ln t]' \\
 & & &= e^{2t} 2 \ln t + e^{2t} \frac{1}{t}
 \end{aligned}$$

$$\begin{aligned}
 \text{b. } P(t) &= \frac{3t-2}{4+t^2} & P'(t) &= \left[\frac{3t-2}{4+t^2} \right]' \\
 & & &= \frac{(4+t^2) [3t-2]' - (3t-2) [4+t^2]'}{(4+t^2)^2} \\
 & & &= \frac{(4+t^2) 3 - (3t-2) (0+2t)}{(4+t^2)^2} \\
 & & &= \frac{12-6t^2}{(4+t^2)^2}
 \end{aligned}$$

$$\begin{aligned}
\text{c. } P(t) &= \frac{e^{2t}}{\ln t} & P'(t) &= \left[\frac{e^{2t}}{\ln t} \right]' \\
& & &= \frac{\ln t [e^{2t}]' - e^{2t} [\ln t]'}{(\ln t)^2} \\
& & &= \frac{(\ln t) e^{2t} 2 - e^{2t} \frac{1}{t}}{(\ln t)^2} \\
& & &= e^{2t} \frac{2t(\ln t) - 1}{t(\ln t)^2}
\end{aligned}$$

Exercises for Section 6.1, Derivatives of Products and Quotients.

Exercise 6.1.1 The word *differentiate* means ‘find the derivative of’.

Differentiate

$$\begin{array}{lll}
\text{a. } P(t) = \frac{e^{-3t}}{t^2} & \text{d. } P(t) = t^2 e^{2t} & \text{g. } P(t) = (e^t)^5 \\
\text{b. } P(t) = e^{2 \ln t} & \text{e. } P(t) = e^{t \ln 2} & \text{h. } P(t) = \frac{t-1}{t+1} \\
\text{c. } P(t) = e^t \ln t & \text{f. } P(t) = e^2 & \text{i. } P(t) = \frac{3t^2 - 2t - 1}{t-1}
\end{array}$$

Exercise 6.1.2 Compute P' for:

$$\begin{array}{ll}
\text{a. } P(t) = t^2 e^t & \text{b. } P(t) = \sqrt{t} e^{\sqrt{t}} \\
\text{c. } P(t) = \frac{t}{1+t^2} & \text{d. } P(t) = \frac{t+1}{t-1} \\
\text{e. } P(t) = e^t \sqrt{1+t} & \text{f. } P(t) = t \ln t - t \\
\text{g. } P(t) = t e^t - e^t & \text{h. } P(t) = t^2 e^t - 2t e^t + 2 e^t \\
\text{i. } P(t) = \frac{\sqrt{t}}{\ln t} & \text{j. } P(t) = e^t \ln t \\
\text{k. } P(t) = \frac{1}{\ln t} & \text{l. } P(t) = e^{(t \ln t)} \\
\text{m. } P(t) = 10 \frac{e^{0.2t}}{9 + e^{0.2t}} & \text{n. } P(t) = \frac{20}{1 + 19 e^{-0.1t}}
\end{array}$$

Exercise 6.1.3 Give reasons for steps (i) – (v) in Equations 6.4 proving Theorem 6.1.1, the derivative of a product formula.

Exercise 6.1.4 Give reasons for steps (i) – (vi) in Equations 6.6 proving Theorem 6.1.2, the derivative of a quotient formula.

Exercise 6.1.5 Write an equation that interprets the mathematical model of logistic growth, Mathematical Model 6.1.1 on page 275, and show that it can be written in the form of Equation 6.9.

Exercise 6.1.6 Is there an example of two functions, $u(x)$ and $v(x)$, for which $[u(x) \times v(x)]' = u'(x) \times v'(x)$?

Exercise 6.1.7 Is there an example of two functions, $u(x)$ and $v(x)$, for which $\left[\frac{u(x)}{v(x)}\right]' = \frac{u'(x)}{v'(x)}$?

Exercise 6.1.8 An examination of 1000 people showed that 41 were carriers (heterozygotic) of the gene for cystic fibrosis. Let p be the proportion of *all* people who are carriers of cystic fibrosis. We can not say with certainty that $p = 41/1000$. For any number p in $[0,1]$, let $L(p)$ be the *likelihood* of the event that 41 of 1000 people are carriers of cystic fibrosis given that the probability of being a carrier is p . Then

$$L(p) = \binom{1000}{41} p^{41} \times (1-p)^{959}$$

where $\binom{1000}{41}$ is a constant¹ approximately equal to 1.3×10^{73} .

- Compute $L'(p)$.
- Find the value \hat{p} of p for which $L'(p) = 0$ and compute $L(\hat{p})$.

The value $L(\hat{p})$ is the maximum value of $L(p)$ and \hat{p} is called the maximum likelihood estimator of p .

Exercise 6.1.9 An examination of 1000 people showed that 41 were carriers (heterozygotic) of the gene for cystic fibrosis. In a second, independent examination of 2000 people, 79 were found to be carriers of cystic fibrosis. Let p be the proportion of *all* people who are carriers of cystic fibrosis. For any number p in $[0,1]$, let $L(p)$ be the likelihood of finding that 41 of 1000 people in one study and 79 out of 2000 people in a second independent study are carriers of cystic fibrosis given that the probability of being a carrier is p . Then

$$L(p) = \binom{1000}{41} p^{41} \times (1-p)^{959} \times \binom{2000}{79} p^{79} \times (1-p)^{1921}$$

where $\binom{1000}{41} \doteq 1.3 \times 10^{73}$ and $\binom{2000}{79} \doteq 1.4 \times 10^{143}$ are constants.

- Simplify $L(p)$.
- Compute $L'(p)$.
- Find the value \hat{p} of p for which $L'(p) = 0$.

The value $L(\hat{p})$ is the maximum value of $L(p)$ and \hat{p} is called the maximum likelihood estimator of p .

Exercise 6.1.10 A bird searches bushes in a field for insects. The total weight of insects found after t minutes of searching a single bush is given by $w(t) = \frac{2t}{t+4}$ grams. Draw a graph of w . From your graph, does it appear that a bird should search a single bush for more than 10 minutes? It takes the bird one minute to move from one bush to another. How long should the bird search each bush in order to harvest the most insects in an hour of feeding?

¹ $\binom{n}{r}$ is the number of r member subsets of a set with n elements, and is equal to $\frac{n!}{r!(n-r)!}$.

Exercise 6.1.11 Van der Waal's equation for gasses at high pressure (20 to 1000 atmospheres, say) is

$$\left(P + \frac{n^2 \times a}{V^2}\right) (V - n * b) = n * R * T \quad (6.10)$$

where n and R are, respectively, the number of moles and the ideal gas law constant, and a and b are constants specific to the gas under study.

- Find $\frac{dP}{dT}$ under the assumption that the volume, V , is constant.
- Find $\frac{dP}{dV}$ under the assumption that the temperature, T , is constant.

Exercise 6.1.12 Let

$$P(t) = \frac{u(t)}{v(t)} = u(t) \times (v(t))^{-1}$$

Use the product rule and power chain rule to show that

$$P'(t) = \frac{u'(t)v(t) - u(t)v'(t)}{v^2(t)}$$

Exercise 6.1.13 Let $P(t) = u(t) \times v(t)$. Then

$$\ln P(t) = \ln(u(t) \times v(t)) = \ln u(t) + \ln v(t) \quad (6.11)$$

Compute the derivative of the two sides of Equation 6.11 using the logarithm chain rule and show that

$$P'(t) = u(t)v'(t) + u'(t)v(t)$$

Exercise 6.1.14 Let $P(t) = u(t)/v(t)$. Then

$$\ln P(t) = \ln\left(\frac{u(t)}{v(t)}\right) = \ln u(t) - \ln v(t) \quad (6.12)$$

Compute the derivative of the two sides of Equation 6.12 using the logarithm chain rule and show that

$$P'(t) = \frac{u(t)v'(t) - u'(t)v(t)}{v^2(t)}$$

Exercise 6.1.15 A useful special case of the quotient formula is the *reciprocal formula*: If $u(t)$ has a derivative and $u(t) \neq 0$ and

$$P(t) = \frac{1}{u(t)}$$

then

$$P'(t) = \frac{-1}{u^2(t)} u'(t)$$

Prove the formula using logarithmic differentiation. That is, write

$$\ln P(t) = \ln\left(\frac{1}{u(t)}\right) = -\ln u(t)$$

and compute the derivatives of both sides using the logarithm chain rule.

We write the formula as

$$\left[\frac{1}{u(t)} \right]' = \frac{-1}{u^2(t)} u'(t) \quad \text{Reciprocal Rule} \quad (6.13)$$

Exercise 6.1.16 Use Equations 6.2 and 6.13 to compute the derivative of

$$P(t) = \frac{t^2 - 1}{t^2 + 1} = (t^2 - 1) \frac{1}{t^2 + 1}$$

Exercise 6.1.17 Provide reasons for steps (ii), (iii), and (iv) in Equations 6.8 computing the derivative of the logistic function. Step (vii) is a hassle. One has to first compute $1 - P(t)/M$ where $P(t) = P_0 M e^{kt} / (M - P_0 + P_0 e^{kt})$. Give it a try.

Exercise 6.1.18 Sketch the graphs of the logistic curve

$$P(t) = \frac{P_0 M e^{rt}}{M - P_0 + P_0 e^{rt}}$$

for

- | | | | | |
|----|--------------------|---------|------------------------------------|------------|
| a. | r = 0.5 | M = 20 | P ₀ = 1, 15, 20, and 30 | 0 ≤ t ≤ 20 |
| b. | r = 0.1 | M = 20 | P ₀ = 1, 15, 20, and 30 | 0 ≤ t ≤ 70 |
| c. | P ₀ = 1 | M = 20 | r = 0.1, 0.3, 0.5, and 0.7 | 0 ≤ t ≤ 50 |
| d. | P ₀ = 1 | r = 0.2 | M = 10, 15, 20, and 25 | 0 ≤ t ≤ 50 |

Exercise 6.1.19 For what population size is the growth rate P' of the logistic population function the greatest? The equation

$$P'(t) = rP(t) \left(1 - \frac{P(t)}{M} \right)$$

provides an answer. Observe that $y = r p (1 - p/M) = r p - (r/M) p^2$ is a quadratic whose graph is a parabola.

The answer to this question is important, for the population size for which P' is greatest is that population that wildlife managers may wish to maintain to provide maximum growth.

Exercise 6.1.20 Crows on the west coast of Canada feed on a mollusk called a whelk (shown in Figure 6.2)². The crows break the whelk shell to obtain the meat inside by lifting the whelk to a height of about 5 meters and dropping it onto a rock.

Copyright permission to use the figures from Reto Zach's papers was given by Brill Publishers, PO Box 9000, 2300 PA Leiden, The Netherlands.

Reto Zach (1978,1979) investigated the behavior of crow feeding as an example of decision making while foraging for food, and concluded that crows break the whelk in a manner that minimized their effort (optimal foraging). Crows find whelks in the intertidal zone near the water, carry it towards the land, fly vertically and drop it from a height for breaking. The vertical ascent and drop are repeated until the whelk breaks. Zach made two interesting observations:

²Reto Zach, Selection and dropping of whelks by northwestern crows, *Behaviour* **67** (1978), 134-147. Reto Zach, Shell dropping: Decision-making and optimal foraging in northwestern crows, *Behaviour* **68** (1979), 106-117.

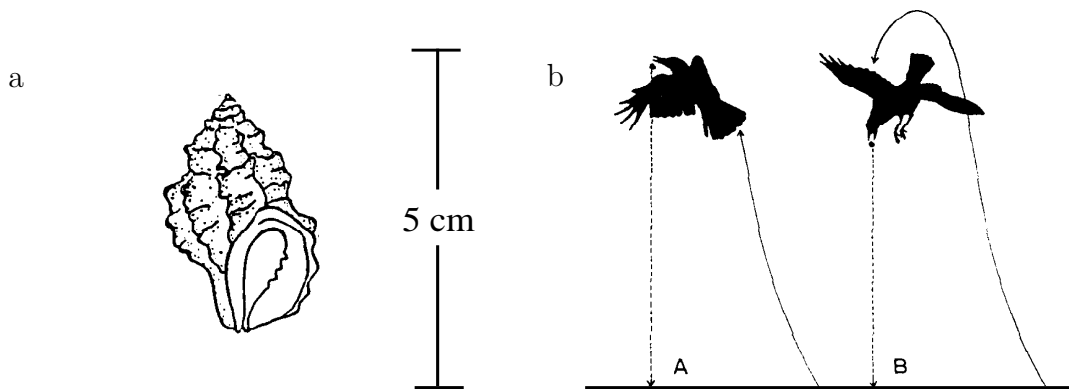

Figure 6.2: a. Schematic drawing of a whelk (Zach, 1978, Figure 1). b. “Flights during dropping. Some crows release whelk at highest point of flight and are unable to see whelk fall (A). Most crows lose some height before dropping but are able to see whelk fall (B).” (*ibid.*, Fig 6.)

1. The crows fed only on large whelk. When large whelk were not available, crows selected another food source.
2. Consistently the crows dropped the whelk from a height of about 5 meters.

Zach gathered whelks from the intertidal zone, separated them into small, medium, and large categories, and dropped them repeatedly at a given height until they broke. He repeated this at varying heights, and his results are shown in Figure 6.3.

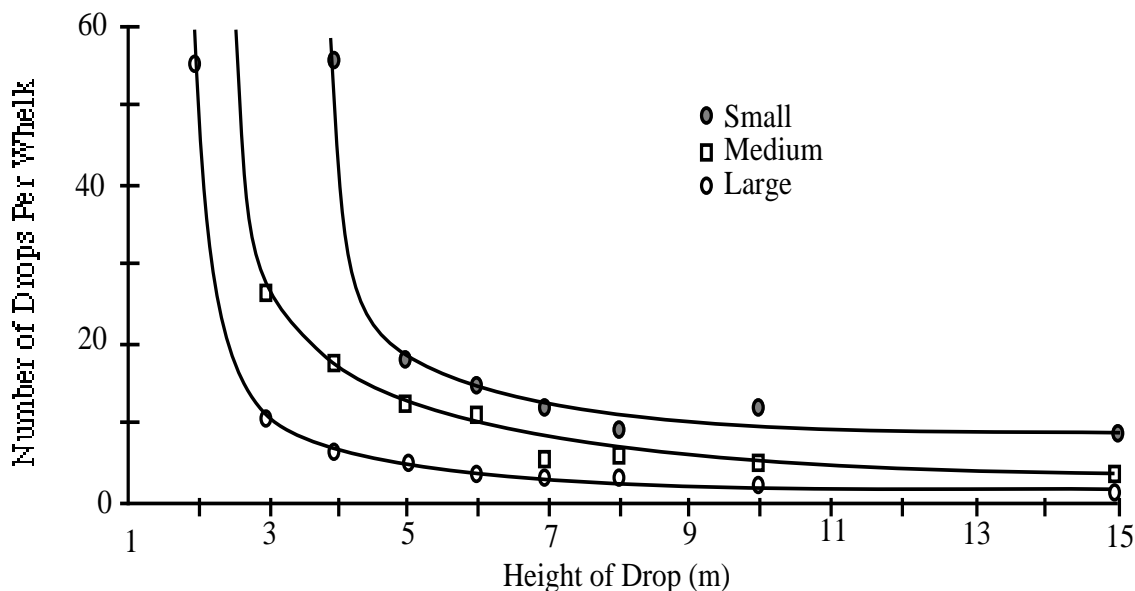

Figure 6.3: Mean number of drops required for breaking large, medium and small whelks dropped from various heights. Curves fitted by eye. (Zach, 1979, Figure 2.)

We read data from the graph for N the number of drops required to break a medium sized whelk from a height H and find that the following hyperbola matches the data:

$$N = 1 + \frac{1}{-0.103 + 0.0389 H} \quad H \geq 2. \tag{6.14}$$

Zach reasoned that the work, W , done to break a whelk by dropping it N times from a height H was equal to $N \times H$. For a medium sized whelk,

$$W = N \times H = \left(1 + \frac{1}{-0.103 + 0.0389 H}\right) \times H \quad H \geq 2. \quad (6.15)$$

- Graph Equation 6.15. From your graph, find (approximately) the value of H for which W is a minimum.
- Compute $\frac{dW}{dH}$ from Equation 6.15. Find the value H_0 of H for which $\frac{dW}{dH} = 0$ and the value W_0 of W corresponding H_0 .
- Explain why the answers to the two previous parts are equal (or very close).
- Interpret the quotient W_0/H_0 .
- Data for large whelk (read from an enlargement of Figure 6.3) are shown in Table 6.1. From the graph in Figure 6.3, read the number of drops required to break a large whelk for Height= 2m and Height= 3m and complete the table.

Table 6.1:
Large Size Whelk

Height of Drop	Number of Drops	[Number of Drops - 1] ⁻¹
2		0.019
3		
4	6.7	0.18
5	4.8	
6	3.8	0.36
7	3.2	0.45
8	2.5	0.67
10	2.6	0.63
15	1.9	1.1

- Find an equation of a hyperbola that matches the data for a large whelk. Note: The number of drops is clearly at least 1, use the equation

$$N = 1 + \frac{1}{a + bH}$$

and find a and b to match the data. The previous equation can be changed to

$$N - 1 = \frac{1}{a + bH}, \quad \frac{1}{N - 1} = a + bH$$

Therefore a graph of $\frac{1}{N-1}$ versus H should be approximately linear, and the coefficients of line fit to that data will be good values for a and b . Find a and b .

- Find the value of H_0 of H that minimizes the work required to break a large whelk.

- h. Find the minimum amount of work required to break a large whelk. On average, how many drops does it take to break a large whelk from the optimum height, H_0 ?

Summary. The work required to break a medium sized whelk is twice that require to break a large whelk, and the optimum height from which to drop a large whelk is 6.1 meters, reasonably close to the 5.58 meters obtained by Zach.

A similar behavior is observed in sea gulls feeding on mussels. A large mussel broken on the second drop by a gull is shown in Figure 6.4; attached to the large mussel shell is a small mussel that the gull did not bother to break.



Figure 6.4: A large mussel shell broken by a gull on the second drop. Attached to it is a small mussel that the gull did not break. (Photo by JLC)

6.2 The chain rule.

The Power Chain Rule, the Exponential Chain Rule, and the Logarithm Chain Rule have a common pattern and we list all three to show the similarity:

If a function, $u(t)$, has derivative then

$$[u(t)^n]' = nu(t)^{n-1} \times [u(t)]' \quad \text{Power Chain Rule}$$

$$[e^{u(t)}]' = ne^{u(t)} \times [u(t)]' \quad \text{Exponential Chain Rule}$$

$$[\ln u(t)]' = \frac{1}{u(t)} \times [u(t)]' \quad \text{Logarithm Chain Rule}$$

All three of these are of the form

$$[G(u(t))]' = G'(u(t)) \times [u(t)]' \quad \text{Chain Rule} \quad (6.16)$$

where

$G'(u(t))$ means $G'(u)$, the derivative of G with respect to u .

Consider

$G(u)$	$G'(u)$	$G(u(t))$	$G'(u(t)) \times [u(t)]'$	Chain Rule
u^n	nu^{n-1}	$(u(t))^n$	$nu(t)^{n-1} \times [u(t)]'$	Power
e^u	e^u	$e^{u(t)}$	$e^{u(t)} \times [u(t)]'$	Exponential
$\ln u$	$\frac{1}{u}$	$\ln(u(t))$	$\frac{1}{u(t)} \times [u(t)]'$	Logarithm

$G'(u)$ in the second column is the derivative with respect to u , the independent variable of G , and will often be computed using a Primary Formula.

Example 6.2.1 Compute $F'(t)$ for $F(t) = (1 - t^2)^3$. Let

$$G(z) = z^3 \quad \text{and} \quad u(t) = 1 - t^2. \quad \text{Then} \quad F(t) = G(u(t)).$$

$$G'(z) = 3z^2 \quad \text{and} \quad [u(t)]' = -2t,$$

$$G'(u(t)) = 3(u(t))^2 = 3(1 - t^2)^2,$$

and

$$F'(t) = G'(u(t)) [u(t)]' = 3(1 - t^2)^2 (-2t)$$

In the form $G(u(t))$, $G(u)$ may be called the 'outside' function and $u(t)$ may be called the inside function. Consider

For	Outside	Inside
$\sqrt{1 + t^2}$	$G(u) = \sqrt{u}$	$u(t) = 1 + t^2$
$\frac{1}{1 + e^t}$	$G(u) = \frac{1}{u}$	$u(t) = 1 + e^t$
$e^{-t^2/2}$	$G(u) = e^u$	$u(t) = -t^2/2$
$\ln(e^t + 1)$	$G(u) = \ln u$	$u(t) = e^t + 1$

Theorem 6.2.1 Chain Rule. Suppose G and u are functions that have derivatives and $G(u(t))$ is defined for all numbers t . Then $G(u(t))$ has a derivative for all t and

$$[G(u(t))] = G'(u(t)) \times [u(t)]' \tag{6.17}$$

Proof: The argument is similar to that for the exponential chain rule. The difference is that we now have a general function $G(u)$ rather than the specific functions e^u . We argue only for u an increasing function, and we need Theorem 4.2.1, The Derivative Requires Continuity.

Let $F = G \circ u$ ($F(t) = G(u(t))$ for all t).

$$\begin{aligned} F'(a) &= \lim_{b \rightarrow a} \frac{F(b) - F(a)}{b - a} \\ &= \lim_{b \rightarrow a} \frac{G(u(b)) - G(u(a))}{b - a} \\ &= \lim_{b \rightarrow a} \frac{G(u(b)) - G(u(a))}{u(b) - u(a)} \lim_{b \rightarrow a} \frac{u(b) - u(a)}{b - a} \quad u(b) - u(a) \neq 0 \\ &= G'(u(a)) u'(a) \end{aligned}$$

The conclusion that

$$\lim_{b \rightarrow a} \frac{G(u(b)) - G(u(a))}{u(b) - u(a)} = G'(u(a))$$

requires some support.

In Figure 6.5, the slope of the secant is $\frac{G(u(b)) - G(u(a))}{u(b) - u(a)}$.

Because $u'(a)$ exists, $u(b) \rightarrow u(a)$ as $b \rightarrow a$. The slope of the secant approaches the slope of the tangent as $u(b) \rightarrow u(a)$, and

$$\lim_{b \rightarrow a} \frac{G(u(b)) - G(u(a))}{u(b) - u(a)} = G'(u(a)).$$

End of proof.

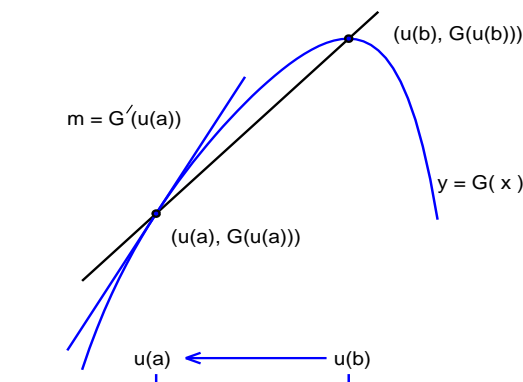

Figure 6.5: Graph of a function $y = G(x)$. As $b \rightarrow a$, $(G(u(b)) - G(u(a)))/(u(b) - u(a)) \rightarrow G'(u(a))$.

Example 6.2.2 Repeated use of the chain rule allows computation of derivatives of some quite complex functions.

Problem. Compute the derivative of

$$F(t) = e^{\sqrt{\ln t}} \quad t > 1 \quad \text{so that} \quad \ln t > 0.$$

Solution. We peel the layers off from the outside. $F(t)$ can be thought of as

$$F(t) = G(H(K(t))), \quad \text{where} \quad G(z) = e^z, \quad H(x) = \sqrt{x}, \quad \text{and} \quad K(t) = \ln t$$

$$\begin{aligned}
[e^{\sqrt{\ln t}}]' &= e^{\sqrt{\ln t}} [\sqrt{\ln t}]' & G(z) &= e^z, & G'(z) &= e^z \\
&= e^{\sqrt{\ln t}} \frac{1}{2\sqrt{\ln t}} [\ln t]' & H(x) &= \sqrt{x}, & H'(x) &= \frac{1}{2\sqrt{x}} \\
&= e^{\sqrt{\ln t}} \frac{1}{2\sqrt{\ln t}} \frac{1}{t} & K(t) &= \ln t, & K'(t) &= \frac{1}{t}
\end{aligned}$$

Extreme Problem. **Argh!** Compute the derivative of

$$F(t) = \left(1 + \sqrt{\ln \frac{1-t}{1+t}}\right)^4$$

$$\begin{aligned}
\left[\left(1 + \sqrt{\ln \frac{1-t}{1+t}}\right)^4\right]' &= 4 \left(1 + \sqrt{\ln \frac{1-t}{1+t}}\right)^3 \left[1 + \sqrt{\ln \frac{1-t}{1+t}}\right]' \\
&= 4 \left(1 + \sqrt{\ln \frac{1-t}{1+t}}\right)^3 \left(0 + \frac{1}{2} \frac{1}{\sqrt{\ln \frac{1-t}{1+t}}} \left[\ln \frac{1-t}{1+t}\right]'\right) \\
&= 4 \left(1 + \sqrt{\ln \frac{1-t}{1+t}}\right)^3 \frac{1}{2} \frac{1}{\sqrt{\ln \frac{1-t}{1+t}}} \left(\frac{1}{1+t} \left[\frac{1-t}{1+t}\right]'\right) \\
&= 4 \left(1 + \sqrt{\ln \frac{1-t}{1+t}}\right)^3 \frac{1}{2} \frac{1}{\sqrt{\ln \frac{1-t}{1+t}}} \frac{1}{1+t} \frac{(1+t)(-1) - (1-t)1}{(1+t)^2}
\end{aligned}$$

The chain rule is an investment in the future. It does not immediately expand the collection of functions for which we can compute the derivative. To use the chain rule on $G(u(t))$ we need $G'(u)$ which requires a Primary derivative formula. The relevant Primary derivative formulas so far developed are the power, exponential and logarithm Primary formulas, for which we have already developed chain rules. In the next chapter, we develop the Primary formula

$$[\sin t]' = \cos t$$

Then from the chain rule of this section, we immediately have the chain rule

$$[\sin(u(t))]' = \cos(u(t)) u'(t)$$

Using this we can, for example, compute $[\sin(\pi t)]'$ as

$$\begin{aligned}
[\sin(\pi t)]' &= \cos(\pi t) [\pi t]' \\
&= \cos(\pi t) \pi
\end{aligned}$$

Leibnitz notation. The Leibnitz notation makes the chain rule look deceptively simple. For $G(u(t))$ one has

$$[G(u(t))]' = \frac{dG}{dt} \quad G'(u(t)) = \frac{dG}{du} \quad [u(t)]' = \frac{du}{dt}.$$

Then the chain rule is

$$\frac{dG}{dt} = \frac{dG}{du} \frac{du}{dt}$$

Example 6.2.3 Find $\frac{dy}{dt}$ for $y(t) = (1 + t^4)^7$. $y(t)$ is the composition of $G(u) = u^7$ and $u(t) = 1 + t^4$. Then

$$\begin{aligned} \frac{dG}{du} &= \frac{d}{du} u^7 &= 7u^6 \\ \frac{du}{dt} &= \frac{d}{dt} (1 + t^4) &= 4t^3 \\ \frac{dG}{dt} &= \frac{dG}{du} \frac{du}{dt} &= 7u^6 \times 4t^3 = 7(1 + t^4)^6 4t^3 \end{aligned}$$

Exercises for Section 6.2, The chain rule.

Exercise 6.2.1 Use the chain rule to differentiate $P(t)$ for

- | | |
|--|-----------------------------------|
| a. $P(t) = e^{(-t^2)}$ | b. $P(t) = (e^t)^2$ |
| c. $P(t) = e^{2 \ln t}$ | d. $P(t) = \ln e^{2t}$ |
| e. $P(t) = \ln(2\sqrt{t})$ | f. $P(t) = \sqrt{2 \ln t}$ |
| g. $P(t) = \sqrt{e^{2t}}$ | h. $P(t) = \sqrt{e^{(-t^2)}}$ |
| i. $P(t) = (t + e^{-2t})^4$ | j. $P(t) = (1 + e^{(-t^2)})^{-1}$ |
| k. $P(t) = \frac{3}{4} (1 - x^2/16)^{1/2}$ | l. $P(t) = (t + \ln(1 + 2t))^2$ |

Exercise 6.2.2 Use the Leibnitz notation for the chain rule to find $\frac{dy}{dt}$ for

- | | |
|---------------------------------|--|
| a. $y(t) = e^{(-t^2)}$ | b. $y(t) = (e^t)^2$ |
| c. $y(t) = e^{2 \ln t}$ | d. $y(t) = \left(\frac{e^t}{1 + e^t}\right)^2$ |
| e. $y(t) = \sqrt{2t^2 - t + 1}$ | f. $y(t) = (t^2 + 1)^3$ |

Compare your answers for a - c with those of Exercise 6.2.1 a - c.

Exercise 6.2.3 In Chapter 7 we show that $[\cos(t)]' = -\sin(t)$. Use this formula and $[\sin t]' = \cos t$ written earlier in this chapter to differentiate:

- | | |
|----------------------------|------------------------------------|
| a. $y(t) = \cos(2t)$ | b. $y(t) = \sin(\frac{\pi}{2}t)$ |
| c. $y(t) = e^{\cos t}$ | d. $y(t) = \cos(e^t)$ |
| e. $y(t) = \sin(\cos t)$ | f. $y(t) = \sin(\cos e^t)$ |
| g. $y(t) = \ln(\sin t)$ | h. $y(t) = \sec t = (\cos t)^{-1}$ |
| i. $y(t) = \ln(\cos(e^t))$ | j. $y(t) = \ln(\cos(e^{\sin t}))$ |

Exercise 6.2.4 The Doppler effect. You are standing 100 meters south of a straight train track on which a train is traveling from west to east at the speed 30 meters per second. See Figure 6.2.4. Let $y(t)$ be the distance from the train to you and $|x(t)|$ be the distance from the train to the point on the track nearest you; $x(t)$ is negative when the train is west of the point on the track nearest you.

- Write $y(t)$ in terms of $x(t)$.
- Find $y'(t)$ for a time t at which $x(t) = -200$
- Time is measured so that $x(0) = 0$. Write an equation for $x(t)$.
- Write an equation for $y'(t)$ in terms of t .
- The whistle from the train projects sound waves at frequency f cycles per second. The frequency, f_L , of the sound reaching your ear is

$$f_L(t) = \frac{331.4}{331.4 + y'(t)} f \frac{\text{cycles}}{\text{second}} \quad (6.18)$$

331.4 m/s is the speed of sound in air. Draw a graph of $f_L(t)$ assuming $f = 500$.

Derivation of Equation 6.18 for the Doppler effect. A sound of frequency f traveling in still air has wave length $(331.4 \text{ m/s})/(f \text{ cycles/s}) = (331.4/f) \text{ m/cycle}$. If the source of the sound is moving at a velocity v with respect to a listener, the wave length of the sound reaching the listener is $((331.4 + v)/f) \text{ m/cycle}$. These waves travel at 331.4 m/sec, and the frequency f_L of these waves reaching the listener is

$$f_L = \frac{331.4 \text{ m/s}}{((331.4 + v)/f) \text{ m/cycle}} = \frac{331.4}{331.4 + v} f \frac{\text{cycles}}{\text{second}}$$

High frequency sound waves may be used to measure the rate of blood flow in an artery. A high frequency sound is introduced on the skin surface above the artery, and the frequency of the waves reflected from the arterial flow is measured. The difference in frequencies emitted and received is used to measure blood velocity.

Figure for Exercise 6.2.4 A train and track with listener location. As drawn, $x(t)$ is negative

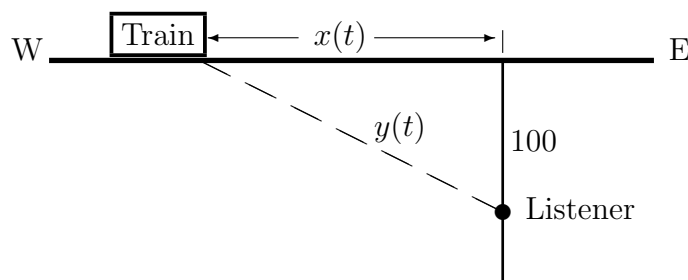

Exercise 6.2.5 Air is being pumped into a spherical balloon at the rate of $1000 \text{ cm}^3/\text{min}$. At what rate is the radius of the balloon increasing when the volume is 3000 cm^3 ? Note: $V(t) = \frac{4}{3} \pi r^3(t)$.

Exercise 6.2.6 Consider a spherical ice ball that is melting. A reasonable model is:

Mathematical Model.

1. The rate at which heat is transferred to the ice ball is proportional to the surface area of the ice ball.
2. The rate at which the ball melts is proportional to the rate at which heat is transferred to the ball.

The volume, V , of a sphere of radius r is $\frac{4}{3}\pi r^3$ and its surface area, S , is $4\pi r^2$. From 1 and 2 we conclude that *the rate of change of volume of the ice ball is proportional to the surface area of the ice ball*.

- a. Write an equation representative of the previous italicized statement.
- b. As the ball melts, V , r , and S change with time. Differentiate $V(t) = \frac{4}{3}\pi r^3(t)$ to obtain

$$V'(t) = 4\pi r^2(t)r'(t)$$

- c. Use your equation from (a) and the equation from (b) to show that

$$r'(t) = K \quad \text{where } K \text{ is a constant}$$

- d. Why should K be negative?
- e. Because K should be negative, we write

$$r'(t) = -K$$

A good candidate for $r(t)$ is

$$r(t) = -Kt + C \quad \text{where } C \text{ is a constant}$$

Why?

f. Only discussion included in this part. With $r(t) = -KT + C$ we find that

$$W(t) = A(1 - t/B)^3 \quad \text{where } W(t) \text{ is the weight of the ball}$$

and A and B are constants. In order to test this conclusion, we filled a plastic ball about the size of a volley ball with water and froze it to -14°C (Figure 6.2.6). One end of a chord (knotted) was frozen into the center of the ball and the other end extended outside the ball as a handle. We removed the plastic and placed the ball in a 10°C water bath, held below the surface by a weight attached to the ball. At four minute intervals we removed the ball and weighed it and returned it to the bath. The data from one of these experiments is shown in Table 6.2.6 and a plot of the data and of a cubic, $y = 3200(1 - t/120)^3$, is shown in the figure of Table 6.2.6. The cubic looks like a pretty good fit to the data, and we might argue that the data is consistent with our model.

There are some flaws with the fit of the cubic, however. The cubic departs from the data at both ends. $y(0) = 3200$, but the ball only weighed 3020 g; the cubic is also above the data at the right end.

g. We found that we could fit the data more closely with an equation of the form

$$W(t) = A(1 - t/100)^\alpha$$

where α is closer to 2 than to 3. Find values for A and α . Note:

$\ln W(t) = \ln A + \alpha \ln(1 - t/100)$. Then reasonable estimates of $\ln A$ and α are the coefficients of a line fit to the graph of $\ln w(t)$ versus $\ln(1 - t/100)$.

h. If the data is not consistent with the model, in what way might the model be deficient?

Figure for Exercise 6.2.6 (h) Pictures of an ice ball used in the experiments described in Exercise 6.2.6.

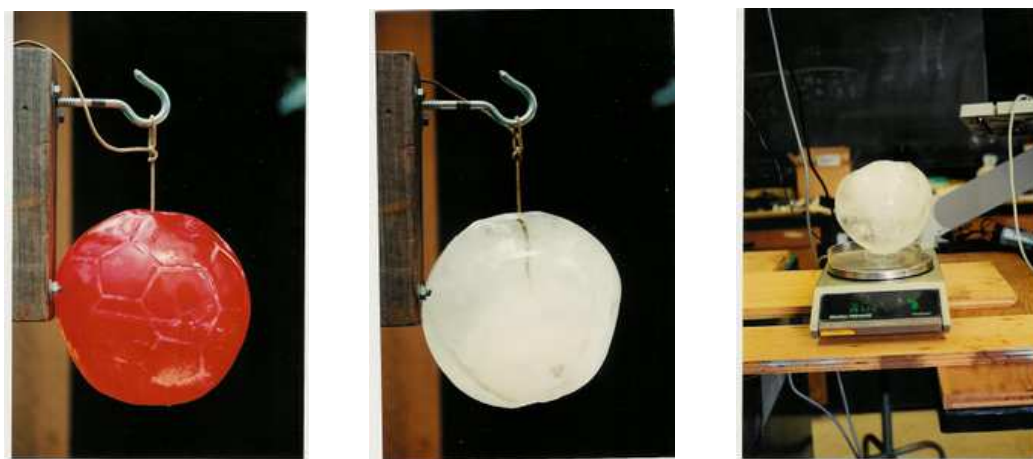
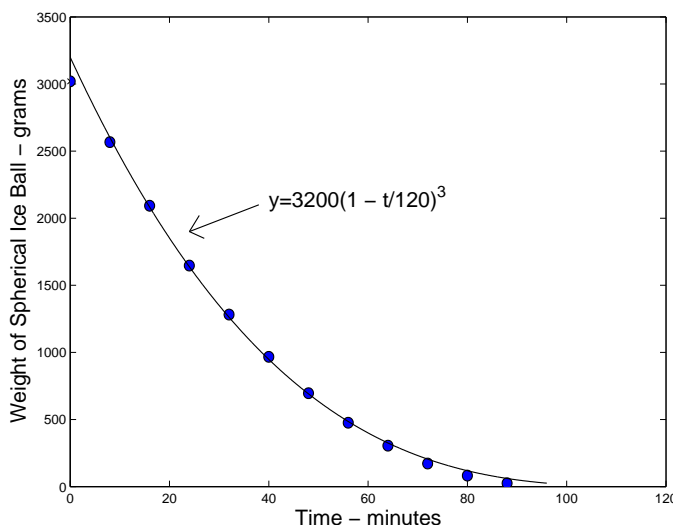

Table for Exercise 6.2.6 Data from an ice ball melt experiment described in Exercise 6.2.6.

Time (m)	Weight (g)
0	3020
4	2567
8	2093
12	1647
16	1282
20	967
24	696
28	476
32	305
36	172
40	82
44	25



6.3 Derivatives of inverse functions.

The inverse of a function was defined in Definition 2.6.2 in Section 2.6.2. The natural logarithm function is the inverse of the exponential function, $f(t) = \sqrt{t}$ is the inverse of $g(t) = t^2, t \geq 0$, and $f(t) = \sqrt[3]{t}$ is the inverse of $g(t) = t^3$, are familiar examples. We show here that *the derivative of the inverse f^{-1} of a function f is the reciprocal of the derivative of f* , but this phrase has to be explained carefully.

Example 6.3.1 The linear functions

$$y_1(x) = 1 + \frac{3}{2}x \quad \text{and} \quad y_2(x) = -\frac{2}{3} + \frac{2}{3}x$$

are each inverses of the other, and their slopes ($3/2$ and $2/3$) are reciprocals of each other.

Explore 6.3.1 Show that in the previous example, $y_1(y_2(x)) = x$ and $y_2(y_1(x)) = x$.

The crucial point is shown in the graphs of y_1 and y_2 in Figure 6.6. Each graph is the image of the other by a reflection about the line $y = x$. One line contains the points (a, b) and (c, d) and another line contains the points (b, a) and (d, c) .

The relation important to us is that their slopes are reciprocals, a general property of a function and its inverse. Specifically,

$$m_1 = \frac{d - b}{c - a} \qquad m_2 = \frac{d - b}{c - a} = \frac{1}{m_1}$$

Example 6.3.2 Figure 6.7 shows the graph of

$$E(x) = e^x \quad \text{and its inverse} \quad L(x) = \ln x$$

The point $(x_3, 3)$ has y-coordinate 3. Because $E'(x) = E(x)$ the slope of E at $(x_3, 3)$ is 3. The point $(3, x_3)$ is the reflection of $(x_3, 3)$ about $y = x$ and the graph of L has slope $1/3$ at $(3, x_3)$ because $L'(t) = [\ln t]' = 1/t$. More generally

$$L'(t) = \frac{1}{E'(L(t))} \quad \text{and} \quad E'(t) = \frac{1}{L'(E(t))}$$

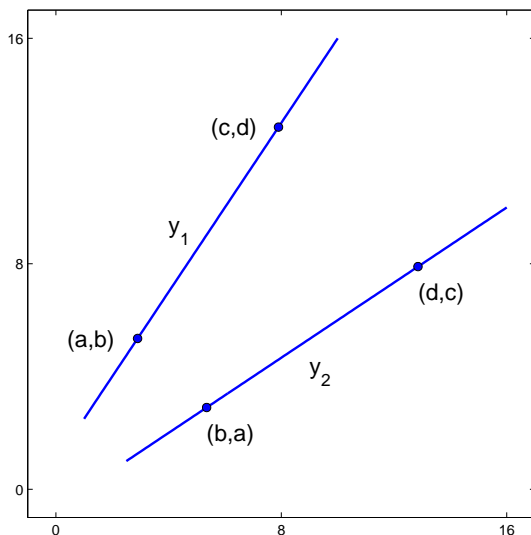

Figure 6.6: Graphs of $y = 1 + (3/2)x$ and $y = -2/3 + (2/3)x$; each is the inverse of the other and the slopes, $3/2$ and $2/3$ are reciprocals.

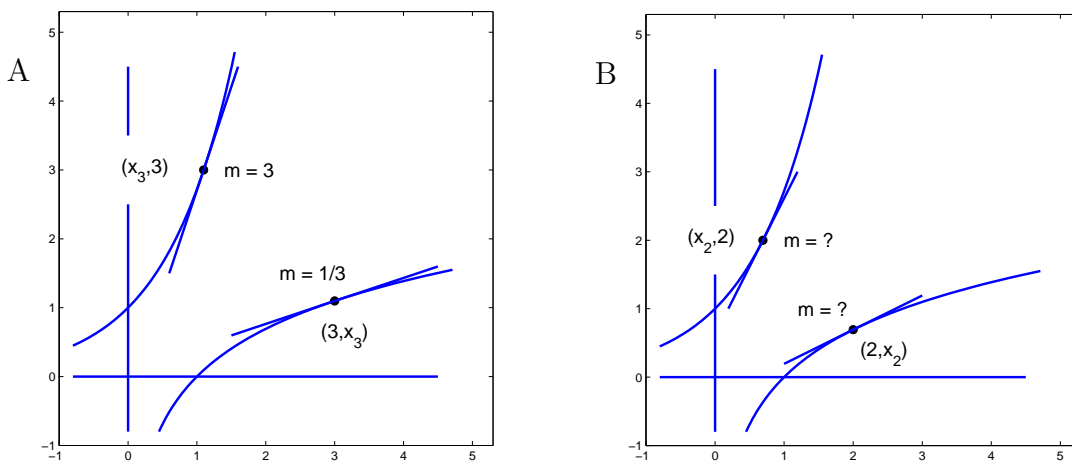

Figure 6.7: Graphs of $E(x) = e^x$ and $L(x) = \ln x$. Each is the inverse of the other. The point A has coordinates $(2, x_2)$ and the slope of L at A is $1/2$.

Explore 6.3.2 (a.) Evaluate x_3 in Figure 6.7A.

(b.) Evaluate x_2 in Figure 6.7B and find the slope at $(x_2, 2)$ and at $(2, x_2)$. ■

The derivative of the inverse of a function. If g is an invertible function that has a nonzero derivative and h is its inverse, then for every number, t , in the domain of g ,

$$g'(h(t)) = \frac{1}{h'(t)} \quad \text{and} \quad g'(t) = \frac{1}{h'(g(t))}.$$

If g is an invertible function and h is its inverse, then for every number, t , in the domain of g ,

$$g(h(t)) = t$$

We differentiate both sides of this equation.

$$[g(h(t))]' = [t]'$$

$$g'(h(t))h'(t) = 1 \quad \text{Uses the Chain Rule}$$

$$h'(t) = \frac{1}{g'(h(t))} \quad \text{Assumes } g'(h(t)) \neq 0$$

Explore 6.3.3 Begin with $h(g(t)) = t$ and show that

$$g'(t) = \frac{1}{h'(g(t))}$$

Example 6.3.3 The function, $h(t) = \sqrt{t}$, $t > 0$ is the inverse of the function, $g(x) = x^2$, $x > 0$.

$$g'(x) = 2x$$

$$h'(t) = \frac{1}{g'(h(t))} = \frac{1}{2h(t)} = \frac{1}{2\sqrt{t}},$$

a result that we obtained directly from the definition of derivative.

Leibnitz notation. The Leibnitz notation for the derivative of the inverse is deceptively simple. Let $y = g(x)$ and $x = h(y)$ be inverses. Then $g'(x) = \frac{dy}{dx}$ and $h'(y) = \frac{dx}{dy}$. The equation

$$h'(t) = \frac{1}{g'(h(t))} \quad \text{becomes} \quad \frac{dx}{dy} = \frac{1}{\frac{dy}{dx}}.$$

Exercises for Section 6.3 Derivatives of inverse functions.

Exercise 6.3.1 Find formulas for the inverses of the following functions. See Section 2.6.2 for a method. Then draw the graphs of the function and its inverse. Plot the point listed with each function and find the slope of the function at that point; plot the corresponding point of the inverse and find the slope of the inverse at that corresponding point.

$$\text{a. } P(t) = 4 - \frac{1}{2}t \quad 0 \leq t \leq 4 \quad (2, 3) \quad \text{b. } P(t) = \frac{1}{1+t} \quad 0 \leq t \leq 2 \quad (1, \frac{1}{2})$$

$$\text{c. } P(t) = \sqrt{4-t} \quad 0 \leq t \leq 4 \quad (2, \sqrt{2}) \quad \text{d. } P(t) = 2^t \quad 0 \leq t \leq 2 \quad (0, 1)$$

$$\text{e. } P(t) = t^2 + 1 \quad -2 \leq t \leq 0 \quad (-1, 2) \quad \text{f. } P(t) = \sqrt{4-t^2} \quad 0 \leq t \leq 2 \quad (1, \sqrt{3})$$

Exercise 6.3.2 The function, $h(t) = t^{1/3}$ is the inverse of the function $g(x) = x^3$. Use steps similar to those of Example 6.3.3 to compute $h'(t)$.

Exercise 6.3.3 The graphs of a function F , its inverse F^{-1} , and its derivative F' are shown in each of Figure 6.3.3 (a) and (b).

- Identify each graph in Figure 6.3.3 (a) as F , F^{-1} or F' .
- Identify each graph in Figure 6.3.3 (b) as F , F^{-1} or F' .

Figure for Exercise 6.3.3 Graphs of a function F , F^{-1} , and F' . See Exercise 6.3.3.

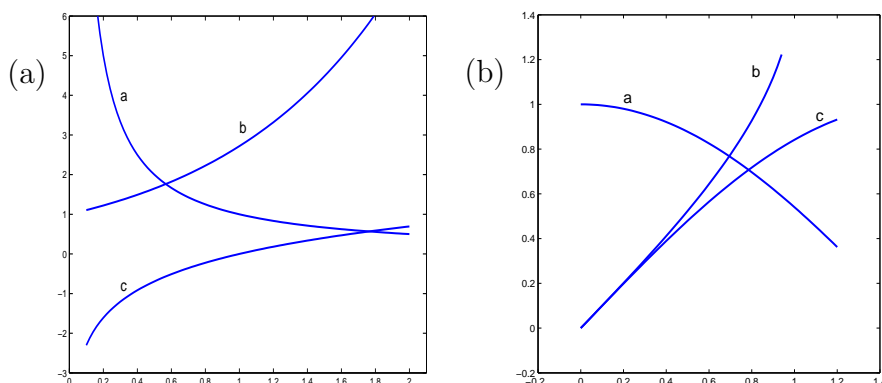

6.4 Summary of Chapter 6.

The thrust of this chapter is to expand your ability to compute derivatives of functions. We have now introduced all of the combination derivative formulas that you will need. Together with the Primary derivative formulas already introduced and two others to be presented in the next chapter, Chapter 7, Derivatives of the Trigonometric Functions, you will be able to compute the derivatives of all of the functions you will meet in ordinary work. The basic formulas that you need are shown below. You need to be able to use them forward *and backward*. That is, given a function, find its derivative, and given a derivative of a function, identify the function, or several such functions that have that same derivative. The *backward* process is crucial to the application of the Fundamental Theorem of Calculus, introduced in Chapter 10

The complete list of derivative formulas that you need is:

Primary Formulas

$$[C]' = 0$$

$$[t^n]' = nt^{n-1}$$

$$[e^t]' = e^t$$

$$[\ln t]' = \frac{1}{t}$$

$$[\sin t]' = \cos t$$

$$[\cos t]' = -\sin t$$

Combination formulas

$$[u + v]' = [u]' + [v]'$$

$$[Cu]' = C[u]'$$

$$[uv]' = [u]'v + u[v]'$$

$$\left[\frac{u}{v}\right]' = \frac{v[u]' - u[v]'}{v^2}$$

$$[G(u)]' = G'(u)u'$$

Chapter Exercise 6.4.1 Differentiate

a. $P(t) = t^4 + e^{2t}$

b. $P(t) = t^4 e^{2t}$

c. $P(t) = \frac{t^4}{e^{2t}}$

d. $P(t) = (e^{2t})^4$

e. $P(t) = e^{2t^4}$

f. $P(t) = (t^2 + 1)^4 (5t + 1)^7$

g. $P(t) = (\ln t)^3$

h. $P(t) = (e^{3t} \ln 2t)^4$

i. $P(t) = \frac{\ln t}{t}$

j. $P(t) = t \ln t - t$

k. $P(t) = \frac{1}{\ln t}$

l. $P(t) = e^{(\ln t)}$

m. $P(t) = \frac{5t^2 - 2t - 7}{t^2 + 1}$

n. $P(t) = \frac{(t+2)^2}{t^2 + 2}$

Chapter Exercise 6.4.2 Data from another of the ice ball experiments (see Exercise 6.2.6) are shown in Table 6.4.1.

- Find a number A so that $W(t) = 3200(1 - t/A)^3$ is close to the data.
- Find a number B so that $W(t) = 3100(1 - t/B)^2$ is close to the data.
- Which of the two functions is closer to the data?

Close to the data may be defined in at least two ways. For several values of A , compute

$$S1 = |w_1 - 3200(1 - t_1/A)^3| + |w_2 - 3200(1 - t_2/A)^3| + \cdots + |w_{21} - 3200(1 - t_{21}/A)^3|$$

$$S2 = (w_1 - 3200(1 - t_1/A)^3)^2 + (w_2 - 3200(1 - t_2/A)^3)^2 + \cdots + (w_{21} - 3200(1 - t_{21}/A)^3)^2$$

and select the values, $A1$ and $A2$, of A for which $S1$ and $S2$, respectively, are the smallest. Then define $W1(t) = 3200(1 - t/A1)^3$ and $W2(t) = 3200(1 - t/A2)^3$. MATLAB code to do this follows.

Discuss the difference between $S1$ and $S2$.

Alter the code to do part b, and then answer part c.

```
close all;clc;clear
t= [0:4:80];
w=[3085 2855 2591 2227 2085 1855 1645 1436 1245 1097 ...
    908 763 534 513 407 316 216 164 110 88 34];
AA = [80:1:120];

for i = 1:length(AA)
    sum1(i) = 0.0;    sum2(i) = 0.0;
    for k = 1:21
        sum1(i) = sum1(i)+ abs((w(k)-3200*(1-t(k)/AA(i))^3));
        sum2(i) = sum2(i)+(w(k)-3200*(1-t(k)/AA(i))^3)^2;
    end
end

[S1 I1] = min(sum1); A1=AA(I1)
[S2 I2] = min(sum2); A2=AA(I2)

W1=3200*(1-t/A1).^3; W2=3200*(1-t/A2).^3;

plot(t,w,'x',t,W1,'o',t,W2,'+', 'linewidth',2);
```

Table for Chapter Exercise 6.4.1 Weight of an ice ball following immersion in 8° C water.

Time m	0	4	8	12	16	20	24	28	32	36	
Wt g	3085	2855	2591	2337	2085	1855	1645	1436	1245	1097	
Time m	40	44	48	52	56	60	64	68	72	76	80
Wt g	908	763	634	513	407	316	216	164	110	66	34

Chapter 7

Derivatives of the Trigonometric Functions.

Where are we going?

The trigonometric functions, sine and cosine, are useful for describing periodic variation in mechanical and biological systems. The sine and cosine functions and their derivatives are interrelated:

$$[\sin t]' = \cos t$$
$$[\cos t]' = -\sin t$$

The derivative equation

$$y''(t) + y(t) = 0$$

is basic to mathematical models of oscillating processes, and every solution to this equation can be written in the form

$$y(t) = A \cos t + B \sin t$$

where $A = y(0)$ and $B = y'(0)$ are constants.

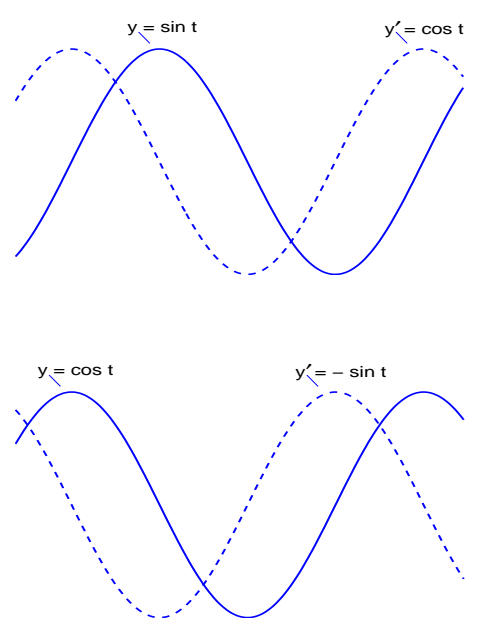

The figure contains two separate graphs. The top graph shows two periodic functions: a solid blue line labeled $y = \sin t$ and a dashed blue line labeled $y' = \cos t$. The solid line starts at the origin (0,0), reaches a peak at $t = \pi/2$, crosses the x-axis at $t = \pi$, reaches a trough at $t = 3\pi/2$, and returns to the x-axis at $t = 2\pi$. The dashed line starts at its maximum value of 1 at $t = 0$, crosses the x-axis at $t = \pi/2$, reaches its minimum value of -1 at $t = 3\pi/2$, and returns to the x-axis at $t = 2\pi$. The bottom graph shows two periodic functions: a solid blue line labeled $y = \cos t$ and a dashed blue line labeled $y' = -\sin t$. The solid line starts at its maximum value of 1 at $t = 0$, crosses the x-axis at $t = \pi/2$, reaches its minimum value of -1 at $t = 3\pi/2$, and returns to the x-axis at $t = 2\pi$. The dashed line starts at the origin (0,0), reaches a trough at $t = \pi/2$, crosses the x-axis at $t = \pi$, reaches a peak at $t = 3\pi/2$, and returns to the x-axis at $t = 2\pi$.

7.1 Radian Measure.

Calculus with trigonometric functions is easier when angles are measured in radians. Radian measure of an angle and the trigonometric measures of that angle are all scaled by the length of the radius of a defining circle. For use in calculus you should put your calculator in RADIAN mode.

The circle in Figure 7.1 has radius 1. For the angle z' (the angle $\angle AOC$) the radian measure, the sine, and the cosine are all dimensionless quantities:

$$\begin{aligned} \text{Radian measure of } z' &= \frac{\text{length of arc } \widehat{AC}}{\text{length of the radius}} = \frac{z \text{ cm, m, in, ?}}{1 \text{ cm, m, in, ?}} = z \\ \text{sine of } z' &= \frac{\text{length of the segment } \overline{AB}}{\text{length of the radius}} = \frac{y \text{ cm, m, in, ?}}{1 \text{ cm, m, in, ?}} = y \\ \text{cosine of } z' &= \frac{\text{length of the segment } \overline{OB}}{\text{length of the radius}} = \frac{x \text{ cm, m, in, ?}}{1 \text{ cm, m, in, ?}} = x \end{aligned}$$

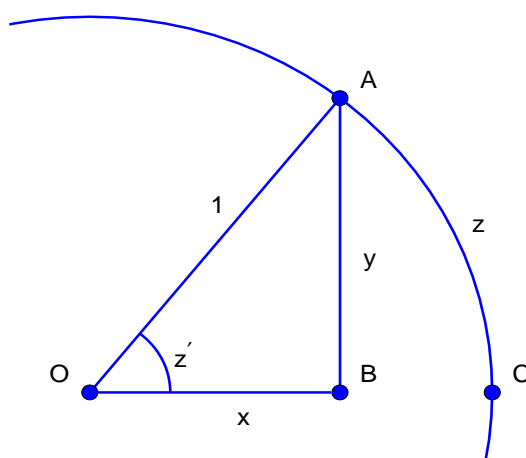

Figure 7.1: A circle with radius 1. The radian measure of the angle z' is z , the length of the arc AC divided by the length of the radius, 1.

It is obvious¹ from the figure that for z' in the first quadrant

$$\begin{aligned} 0 &< \text{Length of } \overline{AB} < \text{Length of } \widehat{AC} \\ 0 &< \sin z' < z \end{aligned}$$

The inequality, $\sin z' < z$, is read, ‘the sine of angle z' is less than z , the radian measure of z' .’ We intentionally blur the distinction between the angle z' and z , the radian measure of z' , to the point that they are used interchangeably. The inequality

$$\sin z' < z \quad \text{is usually replaced with} \quad \sin z < z, \tag{7.1}$$

the sine of z is less than z , where z is a positive number.

The definitions of $\sin z$ and $\cos z$ for angles that are not acute are extended by use of the unit circle, the circle with center at $(0,0)$ and of radius 1. For z positive, consider the arc of length z counterclockwise along the unit circle from $(1,0)$ to a point, (x, y) , in Figure 7.2A. For z negative consider the arc of length $|z|$ clockwise along the unit circle from $(1,0)$ to a point, (x, y) , in Figure 7.2B. In either case

$$\sin z = \frac{y}{1} = y \quad \cos z = \frac{x}{1} = x \tag{7.2}$$

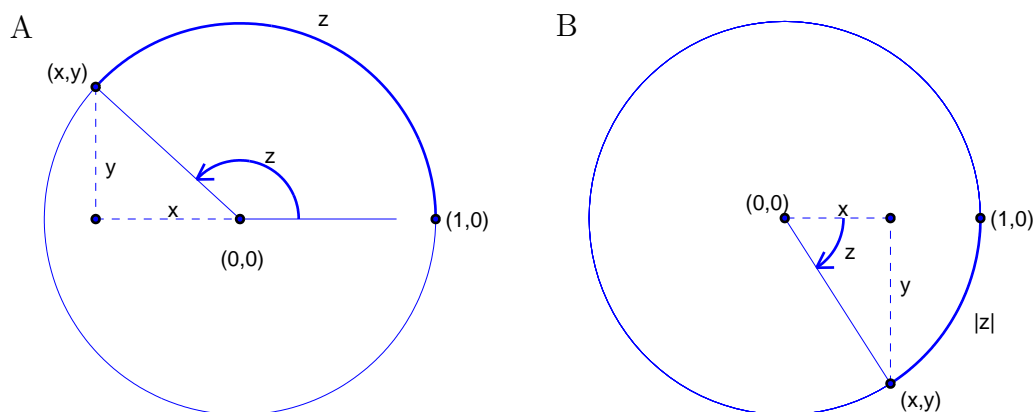

Figure 7.2: The unit circle with A. an arc of length z between 0 and 2π and B. an arc of length $|z|$ for z a negative number.

From Figure 7.2B it can be seen that if z is a negative number then

$$z < \sin z < 0 \tag{7.3}$$

A single statement that combines Equations 7.1 and 7.3 is written:

$$|\sin z| < |z| \quad \text{for all numbers } z \tag{7.4}$$

We need this inequality for computing $[\sin t]'$ in the next section, and we also need the inequality

$$|z| < |\tan z| \quad \text{for } \frac{\pi}{2} < z < \frac{\pi}{2}. \tag{7.5}$$

To see this, for $z > 0$, examine the circle with radius 1 in Figure 7.3,

$$z = \frac{\widehat{AC}}{1} = \widehat{AC}, \quad \text{and} \quad \tan z = \frac{\overline{CD}}{\overline{OC}} = \overline{CD}.$$

We need to show that $\widehat{AC} < \overline{CD}$ which appears reasonable from the figure, but we present a proof. *Proof.* The area of the sector of the circle OAC is equal to the area of the whole circle times the ratio of the length of the arc \widehat{AC} to the circumference of the whole circle. Thus

$$\text{Area of sector } OAC = \pi 1^2 \times \frac{\widehat{AC}}{2\pi \times 1} = \frac{\widehat{AC}}{2}$$

The area of the triangle $\triangle OCD$ is

$$\text{Area } \triangle OCD = \frac{1}{2} \times 1 \times \overline{CD} = \frac{\overline{CD}}{2}$$

The sector OAC is contained in the triangle $\triangle OCD$ so that the area of sector OAC is less than the area of triangle $\triangle OCD$. Therefore

$$\frac{\widehat{AC}}{2} < \frac{\overline{CD}}{2}, \quad \widehat{AC} < \overline{CD}, \quad \text{and} \quad z < \tan z.$$

¹Should this not be obvious then reflect the figure about the horizontal line through O , B , and C and let A' be the image of A under the reflection. The length of the chord $A'BA$ is less than the length of the arc, $A'CA$ (the straight line path is the shortest path between two points).

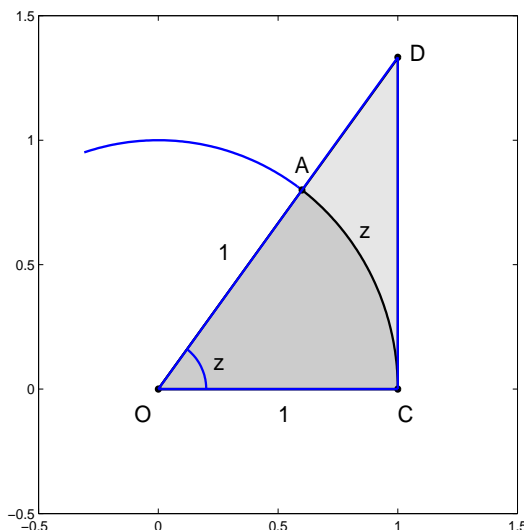

Figure 7.3: The unit circle and an angle z , $0 < z < \pi/2$.

An argument for Equation 7.5 for $z < 0$ can be based on the reflection of Figure 7.3 about the interval OC . *End of Proof.*

In addition to the basic trigonometric identities, ($\sin^2 t + \cos^2 t = 1$, $\tan t = \sin t / \cos t$, etc.) the double angle trigonometric formulas are critical to this chapter:

$$\sin(A + B) = \sin A \cos B + \cos A \sin B \quad \cos(A + B) = \cos A \cos B - \sin A \sin B. \quad (7.6)$$

From these you are asked to prove in Exercises 7.1.3

$$\begin{aligned} \sin x - \sin y &= 2 \cos \left(\frac{x + y}{2} \right) \sin \left(\frac{x - y}{2} \right) \\ \cos x - \cos y &= -2 \sin \left(\frac{x + y}{2} \right) \sin \left(\frac{x - y}{2} \right). \end{aligned}$$

Exercises for Section 7.1 Radian Measure.

Exercise 7.1.1 For small positive values of z , $\sin z < z$ (Equation 7.4), but ‘just barely so’.

a. Compute

$$z - \sin z \quad \text{for } z = 0.1 \quad \text{for } z = 0.01 \quad \text{and for } z = 0.001.$$

b. Compute

$$\frac{\sin z}{z} \quad \text{for } z = 0.1 \quad \text{for } z = 0.01 \quad \text{and for } z = 0.001.$$

c. Note that the slope of the tangent to $y = \sin t$ at $(0,0)$ is

$$[\sin t]'_{t=0} = \lim_{h \rightarrow 0} \frac{\sin(0 + h) - \sin 0}{h} = \lim_{h \rightarrow 0} \frac{\sin h}{h}.$$

What is your best estimate of

$$[\sin t]'_{t=0}?$$

Exercise 7.1.2 For small positive values of z , $z < \tan z$ (Equation 7.5), but ‘just barely so’.

a. Compute

$$\tan z - z \quad \text{for } z = 0.01 \quad \text{for } z = 0.001 \quad \text{and for } z = 0.0001.$$

b. Compute

$$\frac{\tan z}{z} \quad \text{for } z = 0.01 \quad \text{for } z = 0.001 \quad \text{and for } z = 0.0001.$$

c. Note that the slope of the tangent to $y = \tan t$ at $(0,0)$ is

$$[\tan t]'_{t=0} = \lim_{h \rightarrow 0} \frac{\tan(0+h) - \tan 0}{h} = \lim_{h \rightarrow 0} \frac{\tan h}{h}.$$

What is your best estimate of

$$[\tan t]'_{t=0}?$$

Exercise 7.1.3 We need the identities

$$\sin x - \sin y = 2 \cos \frac{x+y}{2} \sin \frac{x-y}{2}$$

$$\cos x - \cos y = -2 \sin \frac{x+y}{2} \sin \frac{x-y}{2}$$

in the next two exercises and in the next section. It is unlikely that you remember them from a trigonometry class. We hope you do remember, however, the double angle formulas 7.6,

$$\sin(A+B) = \sin A \cos B + \cos A \sin B \quad \cos(A+B) = \cos A \cos B - \sin A \sin B.$$

a. Use $\sin(A+B) = \sin A \cos B + \cos A \sin B$ and the identities, $\sin(-A) = -\sin A$ and $\cos(-A) = \cos A$, to show that

$$\sin(A-B) = \sin A \cos B - \cos A \sin B$$

b. Use the equations

$$\sin(A+B) = \sin A \cos B + \cos A \sin B$$

$$\sin(A-B) = \sin A \cos B - \cos A \sin B$$

to show that

$$\sin(A+B) - \sin(A-B) = 2 \cos A \sin B \tag{7.7}$$

c. Solve for A and B in

$$A+B = x$$

$$A-B = y$$

d. Substitute the values for $A+B$, $A-B$, A , and B into Equation 7.7 to obtain

$$\sin x - \sin y = 2 \cos \frac{x+y}{2} \sin \frac{x-y}{2}.$$

e. Use $\cos(A + B) = \cos A \cos B - \sin A \sin B$ to show that

$$\cos x - \cos y = -2 \sin \left(\frac{x + y}{2} \right) \sin \left(\frac{x - y}{2} \right)$$

The argument will be similar to the previous steps.

Exercise 7.1.4 Use steps (i) – (iv) below to show that at all numbers z ,

$$\lim_{h \rightarrow 0} \sin(z + h) = \sin z, \quad (7.8)$$

and therefore conclude that the sine function is continuous.

(i) Write the trigonometric identity,

$$\sin x - \sin y = 2 \cos \left(\frac{x + y}{2} \right) \sin \left(\frac{x - y}{2} \right)$$

with $x = z + h$ and $y = z$.

(ii) Justify the inequality in the following statement.

$$|\sin(z + h) - \sin z| = 2 \left| \cos \left(\frac{2z + h}{2} \right) \right| \left| \sin \left(\frac{h}{2} \right) \right| < 2 \times 1 \times \frac{|h|}{2} = |h|$$

(iii) Suppose ϵ is a positive number. Find a positive number δ so that

$$\text{if } |(z + h) - z| = |h| < \delta \quad \text{then} \quad |\sin(z + h) - \sin z| < \epsilon$$

(iv) Is the previous step useful?

Exercise 7.1.5 Use the Inequality 7.4 $|\sin z| < |z|$ and the trigonometric identity,

$$\cos x - \cos y = -2 \sin \left(\frac{x + y}{2} \right) \sin \left(\frac{x - y}{2} \right)$$

to argue that

$$\lim_{h \rightarrow 0} \cos(z + h) = \cos z,$$

and therefore conclude that the cosine function is continuous.

Hint: Look at the steps (i) - (iv) of Exercise 7.1.4.

7.2 Derivatives of trigonometric functions

We will show that the derivative of the sine function is the cosine function, or

$$[\sin t]' = \cos t \quad (7.9)$$

From this formula and the Combination Derivative formulas 6.1 shown at the beginning of Chapter 6, the derivatives of the other five trigonometric functions are easily computed.

We first show that

$$[\sin t]_{t=0}' = \sin'(0) = 1$$

Assume h is a positive number less than $\pi/2$. We know from Inequalities 7.4 and 7.5 that

$$\sin h < h < \tan h$$

We write

$$\left. \begin{array}{l} \sin h < h < \tan h \\ \sin h < h < \frac{\sin h}{\cos h} \\ 1 < \frac{h}{\sin h} < \frac{1}{\cos h} \quad (i) \\ 1 > \frac{\sin h}{h} > \cos h \quad (ii) \end{array} \right\} \quad (7.10)$$

The inequalities

$$1 > \frac{\sin h}{h} > \cos h$$

present an opportunity to reason in a rather clever way. We wish to know what $\frac{\sin h}{h}$ approaches as the positive number h approaches 0 (as h approaches 0^+). Because $\cos x$ is continuous (Exercise 7.1.5) and $\cos 0 = 1$, $\cos h$ approaches 1 as h approaches 0^+ . Now we have $\frac{\sin h}{h}$ ‘sandwiched’ between two quantities, 1 and a quantity that approaches 1 as h approaches 0^+ . We conclude that $\frac{\sin h}{h}$ also approaches 1 as h approaches 0^+ , and illustrate the result in the array:

$$\text{As } h \rightarrow 0^+ \quad \left\{ \begin{array}{l} 1 < \frac{\sin h}{h} < \cos h \\ \downarrow \qquad \downarrow \qquad \downarrow \\ 1 \leq 1 \leq 1 \end{array} \right.$$

The argument can be formalized with the ϵ, δ definition of limit, but we leave it on an intuitive basis.

We have assumed $h > 0$ in the previous steps. A similar argument can be made for $h < 0$.

We now know that the slope of the graph of the sine function at $(0,0)$ is 1. It is this result that makes radian measure so useful in calculus. For any other angular measure, the slope of the sine function at 0 is not 1. For example, the sine graph plotted in degrees has slope of $\pi/180$ at $(0,0)$.

Because of the continuity of the composition of two functions, Equation 4.4, the equation

$$\lim_{h \rightarrow 0} \frac{\sin h}{h} = 1 \quad (7.11)$$

may take a variety of forms:

$$\lim_{h \rightarrow 0} \frac{\sin 2h}{2h} = 1 \quad \lim_{h \rightarrow 0} \frac{\sin \frac{h}{2}}{\frac{h}{2}} = 1 \quad \lim_{h \rightarrow 0} \frac{\sin h^2}{h^2} = 1$$

We write a general form:

$$\text{If } \theta(h) \neq 0 \text{ for } h \neq 0 \text{ and } \lim_{h \rightarrow 0} \theta(h) = 0 \text{ then } \lim_{h \rightarrow 0} \frac{\sin \theta(h)}{\theta(h)} = 1 \quad (7.12)$$

We use

$$\lim_{h \rightarrow 0} \frac{\sin \frac{h}{2}}{\frac{h}{2}} = 1.$$

in the next paragraph. We also use the fact that the cosine function is continuous, Exercise 7.1.5.

Now we compute $[\sin t]'$ for any t . By Definition 3.22,

$$[\sin t]' = \lim_{h \rightarrow 0} \frac{\sin(t+h) - \sin t}{h}.$$

With the trigonometric identity

$$\sin x - \sin y = 2 \cos \left(\frac{x+y}{2} \right) \sin \left(\frac{x-y}{2} \right)$$

we get

$$[\sin t]' = \lim_{h \rightarrow 0} \frac{\sin(t+h) - \sin t}{h} \quad (i)$$

$$= \lim_{h \rightarrow 0} \frac{2 \cos \left(\frac{t+h+t}{2} \right) \sin \left(\frac{t+h-t}{2} \right)}{h} \quad (ii)$$

$$= \lim_{h \rightarrow 0} \frac{\cos \left(t + \frac{h}{2} \right) \sin \left(\frac{h}{2} \right)}{\frac{h}{2}} \quad (7.13)$$

$$= \lim_{h \rightarrow 0} \cos \left(t + \frac{h}{2} \right) \lim_{h \rightarrow 0} \frac{\sin \left(\frac{h}{2} \right)}{\frac{h}{2}} \quad (iii)$$

$$= \cos t \lim_{h \rightarrow 0} \frac{\sin \left(\frac{h}{2} \right)}{\frac{h}{2}} \quad (iv)$$

$$= \cos t \times 1 = \cos t \quad (v)$$

We have now shown that $[\sin t]' = \cos t$. The derivatives of the other five trigonometric functions are easily computed using the derivative formulas 6.1 shown at the beginning of Chapter 6.

Derivative of the cosine. We will show that

$$[\cos t]' = -\sin t \quad (7.14)$$

Observe that

$$\sin\left(t + \frac{\pi}{2}\right) = \sin t \cos \frac{\pi}{2} + \cos t \sin \frac{\pi}{2} = \sin t \times 0 + \cos t \times 1 = \cos t$$

Therefore

$$\cos t = \sin\left(t + \frac{\pi}{2}\right) \quad \text{and} \quad [\cos t]' = \left[\sin\left(t + \frac{\pi}{2}\right)\right]'$$

We use the Chain Rule Equation 6.16

$$[G(u(t))]' = G'(u(t)) u'(t) \quad \text{with} \quad G(u) = \sin u \quad \text{and} \quad u(t) = t + \frac{\pi}{2}.$$

Note that $G'(u) = \cos u$ and $u'(t) = 1$.

$$\begin{aligned} [\cos t]' &= \left[\sin\left(t + \frac{\pi}{2}\right)\right]' \\ &= \cos\left(t + \frac{\pi}{2}\right) \left[t + \frac{\pi}{2}\right]' \\ &= \cos\left(t + \frac{\pi}{2}\right) \times 1 \\ &= \cos t \cos \frac{\pi}{2} - \sin t \sin \frac{\pi}{2} \\ &= -\sin t \end{aligned}$$

We have established Equation 7.14, $[\cos t]' = -\sin t$.

Derivative of the tangent function. We will show that

$$[\tan t]' = \sec^2 t \tag{7.15}$$

using

$$\tan t = \frac{\sin t}{\cos t} \quad \text{and} \quad [\sin t]' = \cos t \quad \text{and} \quad [\cos t]' = -\sin t$$

and the quotient rule for derivatives from Equations 6.1,

$$\left[\frac{u}{v}\right]' = \frac{v u' - u v'}{v^2}.$$

$$\begin{aligned} [\tan t]' &= \left[\frac{\sin t}{\cos t}\right]' \\ &= \frac{\cos t [\sin t]' - \sin t [\cos t]'}{(\cos t)^2} \\ &= \frac{\cos t \cos t - \sin t (-\sin t)}{\cos^2 t} \\ &= \frac{\cos^2 t + \sin^2 t}{\cos^2 t} \\ &= \sec^2 t \end{aligned}$$

In summary we write the formulas

$$[\sin t]' = \cos t \quad 7.9 \qquad [\cos t]' = -\sin t \quad 7.14$$

$$[\tan t]' = \sec^2 t \quad 7.15 \qquad [\cot t]' = -\csc^2 t \quad 7.16$$

$$[\sec t]' = \sec t \tan t \quad 7.17 \qquad [\csc t]' = -\csc t \cot t \quad 7.18$$

You are asked to compute $[\cot t]'$, $[\sec t]'$, and $[\csc t]'$ in Exercise 7.2.5.

Example 7.2.1 We illustrate the use of the derivative formulas for sine, cosine, and tangent by computing the derivatives of

$$\text{a. } y = 3 \sin t \cos t \quad \text{b. } y = \sin^4 t \quad \text{c. } y = \ln(\tan t) \quad \text{d. } y = e^{\sin t}$$

$$\begin{aligned} \text{a. } [3 \sin t \cos t]' &= 3 (\sin t [\cos t]' + [\sin t]' \cos t) \\ &= 3 (\sin t (-\sin t) + \cos t \cos t) \\ &= -3 \sin^2 t + 3 \cos^2 t \end{aligned}$$

$$\text{b. } [\sin^4 t]' = 4 (\sin^3 t) [\sin t]' = 4 (\sin^3 t) \cos t.$$

$$\begin{aligned} \text{c. } [\ln(\tan t)]' &= [(\ln(\sin t)) - (\ln(\cos t))]' = [\ln(\sin t)]' - [\ln(\cos t)]' \\ &= \frac{1}{\sin t} [\sin t]' - \frac{1}{\cos t} [\cos t]' = \frac{1}{\sin t} \cos t - \frac{1}{\cos t} (-\sin t) \\ &= \frac{\cos^2 t + \sin^2 t}{\cos t \sin t} = \sec t \csc t. \end{aligned}$$

$$\text{d. } [e^{\sin t}]' = e^{\sin t} [\sin t]' = e^{\sin t} \cos t$$

Example 7.2.2 The function $F(t) = e^{-t/10} \sin t$ is an example of 'damped oscillation,' an important type of vibration. Its graph is shown in Figure 7.4. The peaks and valleys of the oscillation are marked by values of t for which $F'(t) = 0$. We find them by

$$\begin{aligned} [e^{-t/10} \sin t]' &= e^{-t/10} [\sin t]' + [e^{-t/10}]' \sin t \\ &= e^{-t/10} \cos t - \frac{1}{10} e^{-t/10} \sin t = e^{-t/10} \left(\cos t - \frac{1}{10} \sin t \right) \end{aligned}$$

Now $e^{-t/10} > 0$ for all t ; $F'(t) = 0$ implies that

$$\cos t - \frac{1}{10} \sin t = 0, \quad \tan t = 10, \quad t = (\arctan 10) + n\pi \quad \text{for } n \text{ an integer.} \blacksquare$$

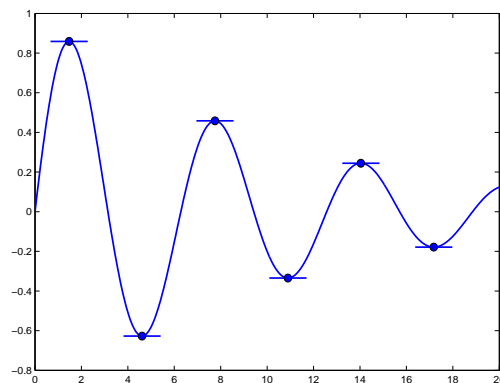

Figure 7.4: Graph of $y = e^{-t/10} \sin t$. The relative high and low points are marked by horizontal tangents and occur at $t = \arctan 10 + n\pi$ for n an integer.

Exercises for Section 7.2 Derivatives of trigonometric functions

Exercise 7.2.1 The difference quotient

$$\frac{F(t+h) - F(t)}{h} \quad \text{approximates} \quad F'(t) \quad \text{when } h \text{ is 'small.'}$$

Make a plot of

$$y = \cos t \quad \text{and of} \quad \frac{\sin(t+0.2) - \sin t}{0.2} \quad -\frac{\pi}{2} \leq t \leq 2\pi.$$

Repeat, using $h = 0.05$ instead of $h = 0.2$.

Exercise 7.2.2 Compute the derivative of

$$y(t) = 1 + 2t - 5t^7 + 2e^{3t} - \ln 6t + 2 \sin t - 3 \cos t$$

Exercise 7.2.3 Compute the derivatives of

- | | | |
|------------------------------------|------------------------------|------------------------------------|
| a. $y = 2 \sin t \cos t$ | b. $y = \sin^2 t + \cos^2 t$ | c. $y = \sec t = \frac{1}{\cos t}$ |
| d. $y = \cot t$ | e. $y = \ln \cos t$ | f. $y = \sin^2 t - \cos^2 t$ |
| g. $y = \csc t = \frac{1}{\sin t}$ | h. $y = \sec^2 t$ | i. $y = e^{\cos t}$ |
| j. $y = \ln(\sec t)$ | k. $y = e^{-t} \sin t$ | l. $y = \tan^2 t$ |
| m. $y = \frac{e^{2t}}{400}$ | n. $y = \ln(\cos^{20} t)$ | o. $y = \frac{\ln t^2}{30}$ |

Exercise 7.2.4 Compute y' and solve for t in $y'(t) = 0$. Sketch the graphs and find the highest and the lowest points of the graphs of:

- | | | | |
|-----------------------------------|---------------------|--------------------------------|---------------------|
| a. $y = \sin t + \cos t$ | $0 \leq t \leq \pi$ | b. $y = e^{-t} \sin t$ | $0 \leq t \leq \pi$ |
| c. $y = \sqrt{3} \sin t + \cos t$ | $0 \leq t \leq \pi$ | d. $y = \sin t \cos t$ | $0 \leq t \leq \pi$ |
| e. $y = e^{-t} \cos t$ | $0 \leq t \leq \pi$ | f. $y = e^{-\sqrt{3}t} \cos t$ | $0 \leq t \leq \pi$ |

Note: $\cos^2 t - \sin^2 t = \cos(2t)$.

Exercise 7.2.5 a. Use $\cot x = \frac{\cos x}{\sin x}$ and the quotient rule to show that

$$[\cot x]' = -\csc^2 x. \quad (7.16)$$

b. Use $\sec x = \frac{1}{\cos x} = (\cos x)^{-1}$ and the power chain rule to show that

$$[\sec x]' = \sec x \tan x. \quad (7.17)$$

c. Show that

$$[\csc x]' = -\csc x \cot x. \quad (7.18)$$

Exercise 7.2.6 The graphs of $y_1 = \cos h$ and $y_2 = 1$ are shown in Figure Ex. 7.2.6. The inequality

$$1 < \frac{\sin h}{h} < \cos h$$

implies that the graph of $y = \frac{\sin h}{h}$, $0 < h < \pi/2$ is 'sandwiched' between y_1 and y_2 . Let F be any function defined on $0 < z \leq 1$ whose graph lies above the graph of y_1 and below the graph of y_2 .

1. Draw the graph of one such function, F .
2. What number does $F(h)$ approach as h approaches 0?

Figure for Exercise 7.2.6 Graphs of $y_1 = 1$ and $y_2 = \cos h$. See Exercise 7.2.6.

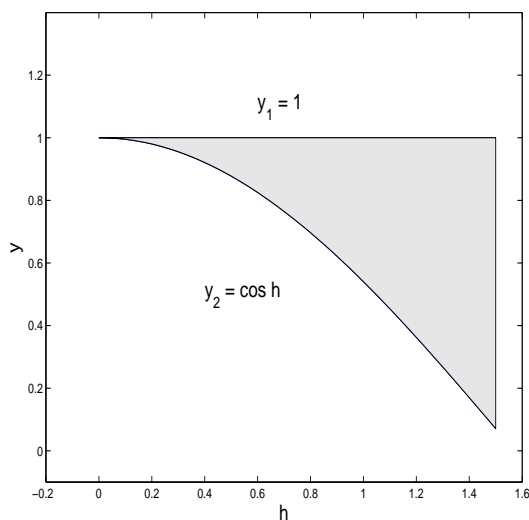

Exercise 7.2.7 Draw a tangent to the graph of the sine function at the point $(0,0)$ in Figure Ex. 7.2.7. Choose two points of the tangent, measure the coordinates of the two points, and use those coordinates to compute the slope of the tangent and $[\sin t]'|_{t=0}$.

Figure for Exercise 7.2.7 Graph of $y = \sin x$. See Exercise 7.2.7.

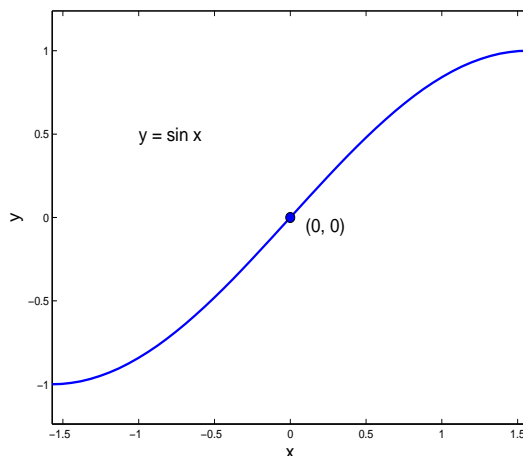

Exercise 7.2.8 Give reasons for steps (i) and (ii) in Equation 7.10 leading to the inequalities

$$1 > \frac{\sin h}{h} > \cos h$$

It is important that $h > 0$; why?

Exercise 7.2.9 The derivative of $y = \cos x$ is defined by

$$[\cos x]' = \lim_{h \rightarrow 0} \frac{\cos(x+h) - \cos x}{h}$$

Make a plot of

$$y = -\sin t \quad \text{and of} \quad \frac{\cos(t+0.2) - \cos t}{0.2} \quad -\frac{\pi}{2} \leq t \leq 2\pi.$$

Repeat, using $h = 0.05$ instead of $h = 0.2$.

Exercise 7.2.10 Show that $[\cos t]' = -\sin t$. To do so, use

$$[\cos t]' = \lim_{h \rightarrow 0} \frac{\cos(t+h) - \cos t}{h}$$

and the trigonometric identity

$$\cos x - \cos y = -2 \sin\left(\frac{x+y}{2}\right) \sin\left(\frac{x-y}{2}\right)$$

The steps will be similar to those of Equation 7.13.

Exercise 7.2.11 We have shown that the slope of the graph of the sine function at $(0,0)$ is 1. Use symmetry of the graph of $y = \sin x$ to find the slope of the graph at the point $(\pi, 0)$. Find an equation of the line tangent to the graph of $y = \sin x$ at the point $(\pi, 0)$. Draw the graph of your line and a graph of $y = \sin x$.

Exercise 7.2.12 Alternate derivation of $[\cos x]' = -\sin x$ using implicit differentiation and $[\sin x]' = \cos x$.

Compute the derivatives of both sides of the identity

$$\sin^2 x + \cos^2 x = 1 \quad \text{and obtain} \quad 2 \sin x \cos x + 2 \cos x [\cos x]' = 0$$

Use the last equation to argue that if $\cos x \neq 0$ then

$$[\cos x]' = -\sin x$$

Exercise 7.2.13 How is the preference in calculus for radian measure of angles for trigonometric functions similar to the preference of the number e as the base of exponential functions?

7.3 The Chain Rule with trigonometric functions.

The Chain Rule 6.16 states that if G and u are functions that have derivatives and the composition of G with u is well defined then

$$[G(u(t))] = G'(u(t)) \times [u(t)] = G'(u(t)) u'(t).$$

With $G(u) = \sin u$ or $\cos u$ or $\tan u$ we have

$$[\sin(u(t))] = \cos(u(t)) \times u'(t) = \cos(u(t)) u'(t),$$

$$[\cos(u(t))] = -\sin(u(t)) u'(t), \quad \text{and}$$

$$[\tan(u(t))] = \sec^2(u(t)) u'(t)$$

Example 7.3.1 For $u(t) = kt$ where k is a constant,

$$[\sin(kt)] = \cos(kt) \times [kt] = \cos(kt) \times k$$

Example 7.3.2 With repeated use of the chain rule, derivatives of some rather difficult and exotic functions can be computed. For example, find y' for

$$y(t) = \ln(\sin(e^{\cos t}))$$

You may find it curious that $y(t)$ is meaningful for all values of t . In the following, we ‘peel one outside layer at a time’.

$$\begin{aligned} y'(t) &= [\ln(\sin(e^{\cos t}))]' && \text{Outside layer} \\ &= \frac{1}{\sin(e^{\cos t})} \times [\sin(e^{\cos t})]' && G(u) = \ln u, \quad G'(u) = \frac{1}{u} \\ &= \frac{1}{\sin(e^{\cos t})} \times \cos(e^{\cos t}) \times [e^{\cos t}]' && G(u) = \sin u, \quad G'(u) = \cos u \\ &= \frac{1}{\sin(e^{\cos t})} \times \cos(e^{\cos t}) \times e^{\cos t} \times [\cos t]' && G(u) = e^u, \quad G'(u) = e^u \\ &= \frac{1}{\sin(e^{\cos t})} \times \cos(e^{\cos t}) \times e^{\cos t} \times (-\sin t) && G(u) = \cos u, \quad G'(u) = -\sin u \\ &= -\sin t \times e^{\cos t} \times \cot(e^{\cos t}) \end{aligned}$$

Example 7.3.3 We will find in later sections that the dynamics of some physical and biological systems are described by equations similar to

$$y''(t) + 2y'(t) + 37y(t) = 0. \tag{7.19}$$

Some of these equations describe functions, $y(t)$, that are defined using sine and cosine functions together with exponential functions. This specific equation has a solution

$$y(t) = e^{-t} \cos 6t \tag{7.20}$$

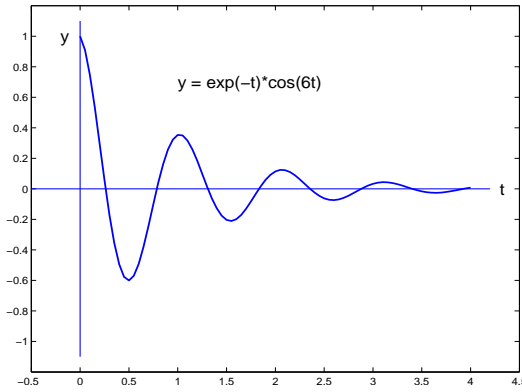

Figure 7.5: The graph of the damped cosine function $y = e^{-t} \cos 6t$.

the graph of which is shown in Figure 7.5. The function is called a ‘damped cosine’ function. It is a cosine function whose amplitude is e^{-t} which decreases with time.

We show that $y(t) = e^{-t} \cos 6t$ solves $y''(t) + 2y'(t) + 37y(t) = 0$.

$$\begin{aligned}
 y'(t) &= [e^{-t} \cos 6t]' \\
 &= [e^{-t}]' \cos 6t + e^{-t} [\cos 6t]' & (i) \\
 &= (-e^{-t}) \cos 6t + e^{-t} (-\sin 6t) \times 6 & (ii)
 \end{aligned} \tag{7.21}$$

$$\begin{aligned}
 y''(t) &= [-e^{-t} \cos 6t - 6e^{-t} \sin 6t]' \\
 &= [-e^{-t} \cos 6t]' - 6[e^{-t} \sin 6t]' & (iii) \\
 &= -[e^{-t}]' \cos 6t - e^{-t} [\cos 6t]' \\
 &\quad -6([e^{-t}]' \sin 6t + e^{-t} [\sin 6t]') & (iv) \\
 &= e^{-t} \cos 6t + 6e^{-t} \sin 6t + 6e^{-t} \sin 6t - 36e^{-t} \cos 6t & (v) \\
 &= 12e^{-t} \sin 6t - 35e^{-t} \cos 6t
 \end{aligned} \tag{7.22}$$

We next substitute $y(t) = e^{-t} \cos 6t$, and the computed values for $y'(t)$ and $y''(t)$ into $y'' + 2y' + 37y$ and confirm the solution.

$$\begin{aligned}
 &y'' \qquad \qquad \qquad + \qquad \qquad \qquad 2y' \qquad \qquad \qquad + \qquad \qquad \qquad 37y \\
 &12e^{-t} \sin 6t - 35e^{-t} \cos 6t \quad + \quad 2(-e^{-t} \cos 6t - 6e^{-t} \sin 6t) \quad + \quad 37e^{-t} \cos 6t \\
 &= (12 - 2 \times 6)e^{-t} \sin 6t \quad + \quad (-35 - 2 + 37)e^{-t} \cos 6t \quad = 0
 \end{aligned}$$

Example 7.3.4 A searchlight is 400 m from a straight beach and rotates at a constant rate once in two minutes. How fast is the beam moving along the beach when the beam is 600 m from the nearest point, A, of the beach to the searchlight.

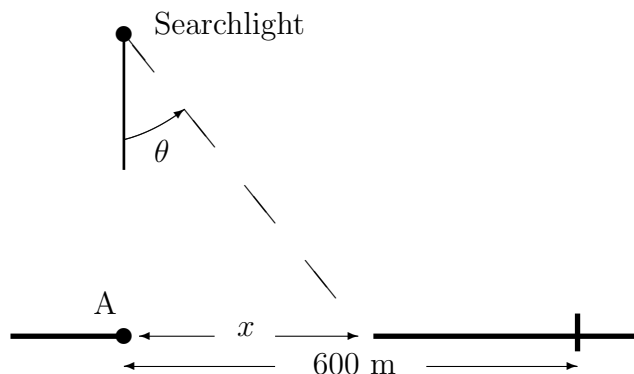

Figure 7.6: Searchlight shining along a beach.

Solution. See Figure 7.6. Let θ measure the rotation of the light with $\theta = 0$ when the light is pointing toward A. Let x be the distance from A to the point where the beam strikes the beach. We have

$$\tan(\theta) = \frac{x}{400}$$

Both θ and x are functions of time and we write.

$$\tan \theta(t) = \frac{x(t)}{400}$$

and differentiate both sides of the equation with respect to t . We get

$$\begin{aligned} [\tan(\theta(t))] &= \left[\frac{x(t)}{400} \right]' \\ \sec^2(\theta(t)) [\theta(t)]' &= \frac{1}{400} [x(t)]' && \text{Tangent Chain, Constant Factor} \\ \sec^2(\theta(t)) \theta'(t) &= \frac{1}{400} x'(t) \end{aligned}$$

The problem is to find $x'(t)$ when $x(t) = 600$. When $x(t) = 600$, $\tan(\theta(t)) = \frac{600}{400} = \frac{3}{2}$, and $\sec^2(\theta(t)) = 1 + \left(\frac{3}{2}\right)^2$. The light rotates once every two minutes, so $\theta'(t) = \frac{2\pi \text{ radians}}{2 \text{ minutes}} = \pi$ radians/minute. Therefore when $x(t) = 600$,

$$x'(t) = 400 \frac{13}{4} \pi \quad \text{meters/minute}$$

Note: Radian is a dimensionless measurement.

Exercises for Section 7.3 The Chain rule with trigonometric functions.

Let $x(t)$ denote the horizontal distance from you to the geese. Then

$$\tan \theta(t) = \frac{600}{x(t)} = 600 (x(t))^{-1}.$$

a. Show that

$$(\sec^2 \theta(t)) \times \theta'(t) = -600 (x(t))^{-2} \times x'(t) \quad (7.23)$$

b. The derivative formulas require angles to be measured in radians. Convert the values of θ in the table to radians.

c. Estimate $\theta'(5)$ in radians per second.

d. Compute $x(5)$

e. Use Equation 7.23 to estimate $x'(t)$ in meters per second for $t = 5$ seconds.

Exercise 7.3.6 In Exercise 7.3.5, the centered difference estimate of $\theta'(5)$ is

$$\theta'(5) \doteq \frac{\theta(10) - \theta(0)}{10 - 0} = \frac{51 \frac{\pi}{180} - 40 \frac{\pi}{180}}{10 - 0} = 0.0192 \text{ radians/second.}$$

a. Estimate x' using this value of θ' .

b. What error in the estimate of $x'(t)$ meters/second might be caused by an error of 0.001 in $\theta'(5)$?

c. With some confidence (and looking at the data), we might argue that

$$\frac{\theta(5) - \theta(0)}{5 - 0} \leq \theta'(5) \leq \frac{\theta(10) - \theta(5)}{10 - 5}$$

Compute these bounds for $\theta'(5)$ and use them in similar computations of $x'(5)$ to compute bounds on the estimate of $x'(5)$.

d. Show that an error of size ϵ in $\theta'(5)$ causes an error of 1200ϵ in $x'(5)$.

Exercise 7.3.7 A piston is linked by a 20 cm tie rod to a crank shaft which has a 5 cm radius of motion (see Figure 7.3.7). Let $x(t)$ be the distance from the rotation center of the crank shaft to the end of the tie rod and $\theta(t)$ be the rotation angle of the crank shaft, measured from the line through the centers of the crank shaft and piston. The crank shaft is rotating at 100 revolutions per minute. The goal is to locate the point of the cylinder at which the piston speed is the greatest.

Note: You may prefer to think of this as fly fishing; the crank shaft (rescaled) is your fly rod rotating about your wrist, the tie rod is your fly line, and the piston is a fish.

a. Find an equation relating $x(t)$ and $\theta(t)$. You will find the Law of Cosines,

$c^2 = a^2 + b^2 - 2ab \cos C$, useful, where a , b , and c are the lengths of the sides of a triangle and C is the angle opposite side c .

b. What is $\theta'(t)$?

c. What values of $x(t)$ are possible?

- d. Differentiate your equation from part (a) to find an equation relating $x'(t)$ to $x(t)$, $\theta(t)$, and $\theta'(t)$.
- e. Evaluate $x(t)$ for $\theta(t) = 0 + 2\pi$. Evaluate $x'(t)$ for $\theta(t) = 0 + 2\pi$.
- f. Evaluate $x(t)$ for $\theta(t) = \frac{\pi}{2} + 2\pi$. Evaluate $x'(t)$ for $\theta(t) = \frac{\pi}{2} + 2\pi$.
- g. Evaluate $x(t)$ for $\theta(t) = 1.35 + 2\pi$. Evaluate $x'(t)$ for $\theta(t) = 1.35 + 2\pi$.

The last two results may seem a bit surprising, but would be intuitive to fly fishermen and fly fisherwomen. We will return to this problem in Example 8.4.3.

Figure for Exercise 7.3.7 Crank shaft, tie rod, and piston for Exercise 7.3.7.

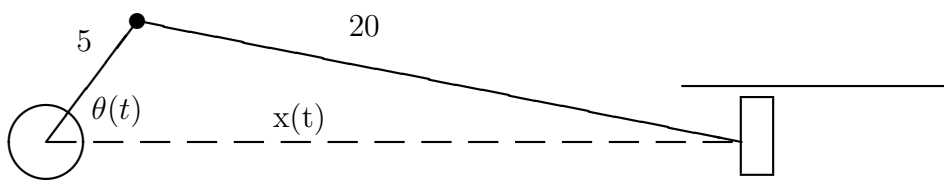

7.4 The Equation $y'' + \omega^2 y = 0$.

In this section:

A principal use of the sine and cosine functions are in the descriptions of *Harmonic Oscillations*. A mass suspended on a spring that is displaced from equilibrium, E , and released is an example of a simple harmonic oscillator. This spring-mass system is modeled by the equations

$$y(0) = A \quad \text{Initial displacement.}$$

$$y'(0) = 0 \quad \text{Initial velocity.}$$

$$y''(t) + \omega^2 y(t) = 0$$

The equations are solved by

$$y(t) = A \cos(\omega t)$$

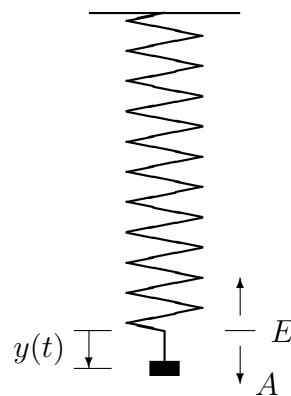

Harmonic oscillations are ubiquitous in the material world. The sine and cosine functions are called the harmonic functions and at least to first approximation are descriptive of sound waves, light waves, planetary motion, tidal motion, ear drum oscillations, swinging pendula, vibrations of an atom, alternating electrical current, earthquake waves, flutter of a leaf, (the list is quite long).

The most simple equation that applies to oscillating systems *in which the resistance to motion is negligible* is:

$$y''(t) + \omega^2 y(t) = 0 \quad (7.24)$$

Generally $y(t)$ is the displacement from equilibrium of some measure of the system. The constant ω measures the strength of the force that restores the system to equilibrium. Solutions to the equation are of the form

$$y(t) = A \sin(\omega t) + B \cos(\omega t) \quad (7.25)$$

where A and B are constants that are determined from information about the state of the system at time 0 (for example, $y(0) = 1$, $y'(0) = 0$ implies that $A = 0$ and $B = 1$). All such functions satisfy $y''(t) + \omega^2 y(t) = 0$. That there are no other solutions follows from the uniqueness of solutions to linear differential equations usually established in differential equation courses.

We first establish that if $y(t) = A \sin(\omega t)$ then $y''(t) + \omega^2 y(t) = 0$.

$$y(t) = A \sin(\omega t)$$

$$\begin{aligned} y'(t) &= A \cos(\omega t) \times [\omega t]' \\ &= A \cos(\omega t) \times \omega \end{aligned}$$

$$\begin{aligned} y''(t) &= [A\omega \cos(\omega t)]' \\ &= A\omega(-\sin(\omega t)) \times [\omega t]' \\ &= -A\omega^2 \sin(\omega t) \end{aligned}$$

It is immediate then that $y''(t) + \omega^2 y(t) = 0$ for

$$y''(t) + \omega^2 y(t) = (-A\omega^2 \sin(\omega t)) + \omega^2 A \sin(\omega t) = 0$$

You are asked to show in Exercises 7.4.4 and 7.4.5 that both $y(t) = B \cos(\omega t)$ and $y(t) = A \sin \omega t + B \cos(\omega t)$ solve $y''(t) + \omega^2 y(t) = 0$.

It is easy to visualize the motion of a mass suspended on a spring and we begin there. However, the mathematics involved is the same in many other systems; one of the powers of mathematics is that a single mathematical formulation may be descriptive of many systems.

It is shown in beginning physics courses that if $y(t)$ measures the displacement from the rest position of a body of mass m suspended on a spring (see Figure 7.7) with spring constant k , then

$$my''(t) + ky(t) = 0$$

. The equation is derived by equating the two forces on the mass,

$$\text{Newton's Second Law of Motion} \quad F_1 = \text{mass} \times \text{acceleration} = m y''$$

$$\text{Hooke's Spring Law} \quad F_2 = -k \times \text{spring elongation} = -k y$$

$$F_1 = F_2 \quad \text{implies that} \quad my'' = -ky, \quad \text{or} \quad my'' + ky = 0. \quad (7.26)$$

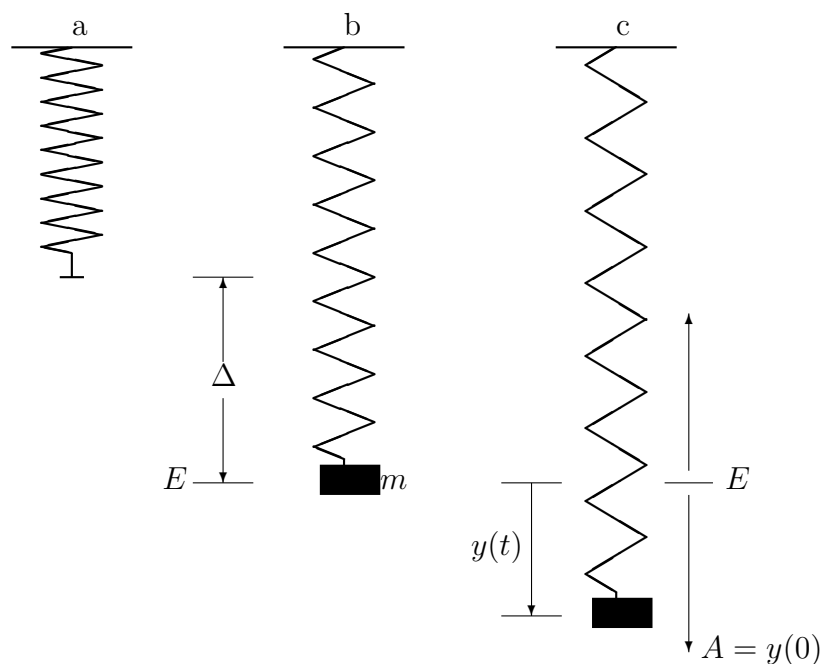

Figure 7.7: Oscillation of a mass attached to a spring. a. Relaxed spring with no mass attached. b. A body of mass m is attached and stretches the spring a distance Δ to an equilibrium position E . c. The body is displaced a distance A below the equilibrium point E and released. $y(t)$ is the displacement of the body from E at time t and is positive when the body is below E .

Assume that the mass is held motionless a distance A below the equilibrium point and at time $t = 0$ the mass is released. Then

$$y(0) = A \quad \text{and} \quad y'(0) = 0$$

If we let $\omega = \sqrt{\frac{k}{m}}$ so that $\omega^2 = \frac{k}{m}$ we have

$$y(0) = A \quad y'(0) = 0 \quad y''(t) + \omega^2 y(t) = 0 \quad (7.27)$$

You will show in Exercise 7.4.4 that the function

$$y(t) = A \cos \omega t.$$

satisfies the three conditions of Equations 7.27. It gives a good description of the motion of a body suspended on a spring.

The number ω is important. On the time interval $[0, 2\pi/\omega]$, $\cos \omega t$ completes one cycle and the position, $y(t)$, of the body progresses from A to $-A$ and back to A . Thus

$$\frac{2\pi}{\omega} = 2\pi \sqrt{\frac{m}{k}} \quad \text{is the **period** of one oscillation.}$$

One time unit divided by the length of a period of oscillation gives the number of oscillations per unit time and

$$\frac{1}{\frac{2\pi}{\omega}} = \frac{\omega}{2\pi} = \frac{1}{2\pi} \sqrt{\frac{k}{m}} \quad \text{is the **frequency** of oscillations.}$$

If k/m is 'large' (stiff spring or small mass) the period will be 'short' and the body oscillates rapidly. If k/m is 'small' (weak spring or large mass) the period will be long, the frequency will be low and the body oscillates slowly.

Example 7.4.1 Suppose a body of mass m is suspended from a spring with spring constant k .

1. If $m = 20 \text{ gm} = 0.020 \text{ Kg}$ and $k = 0.125 \text{ Newtons/meter}$ and the initial displacement, $y_0 = 5 \text{ cm} = 0.05 \text{ m}$, then

$$\omega = \sqrt{\frac{k}{m}} = \sqrt{\frac{0.125 \text{ Kg}}{0.020 \text{ Kg-m/s}^2/\text{m}}} = 2.5/\text{s}$$

and

$$y(t) = 0.05 \cos(2.5t)$$

The period of oscillation is

$$\frac{2\pi}{\omega} = \frac{2\pi}{2.51/\text{s}} = 2.51 \text{ s.}$$

and the frequency of oscillation is approximately

$$60/2.51 = 23.9 \quad \text{oscillations per minute.}$$

2. If $m = 5 \text{ gm} = 0.005 \text{ Kg}$ (one-fourth the previous mass) and $k = 0.125 \text{ Newtons/meter}$ as before, then the period and frequency of oscillation would be

$$\text{Period} = 2\pi\sqrt{\frac{m}{k}} = 2\pi\sqrt{\frac{0.005}{0.125}} = 2\pi \times 0.2 \doteq 1.25 \quad \text{seconds per oscillation}$$

$$\text{Frequency} \doteq \frac{1}{1.25} \quad \text{oscillations per second} = 48 \quad \text{oscillations per minute.}$$

Thus one-fourth the mass oscillates twice as fast.

3. If $m = 20 \text{ gm}$ and the spring extends 16 cm when the body is attached to it, then the spring constant, k is

$$k = \frac{\text{Force}}{\text{Extension}} = \frac{0.02 \times 9.8 \text{ Kg-Force}}{0.16 \text{ meter}} \times \frac{1 \text{ Newton}}{9.8 \text{ Kg-Force}} = 0.125 \quad \text{Newton/meter}$$

It is a curious consequence of the previous analysis that the magnitude of the gravitational field, g , is not reflected in the model equation nor in the solution equation. The role of g is to determine the equilibrium location, E . The period and frequency of the oscillations would be the same on the Moon as on Earth.

There are two important omissions in the previous analysis. We have ignored the mass of the spring (which will also be moving) and we have ignored resistance to movement (by the air and in the spring).

7.4.1 Resistance.

In most systems, the amplitudes of the oscillations decrease with time due to resistance to the movement or *friction* in the system. Resistance is a force directed opposite to the direction of motion and may be modeled by

$$\text{Resistance} = -r \times y'(t)$$

Including the force of resistance with the force of the spring, Equation 7.26 is modified to

$$my''(t) = -ky(t) - ry'(t)$$

or

$$my''(t) + ry'(t) + ky(t) = 0 \quad (7.28)$$

This is referred to as the equation of *damped* motion.

Example 7.4.2 Suppose $m = 20 \text{ gm} = 0.020 \text{ kg}$, $r = 0.06 \text{ Newtons}/(\text{meter}/\text{sec})$ and $k = 0.125 \text{ Newtons}/\text{meter}$. Then the equation of damped motion is

$$0.02y''(t) + 0.06y'(t) + 0.125y(t) = 0 \quad (7.29)$$

We show that a solution to this equation is

$$y(t) = e^{-1.5t} \cos(2t)$$

$$\begin{aligned} y'(t) &= \left[e^{-1.5t} \cos(2t) \right]' \\ &= \left[e^{-1.5t} \right]' \cos(2t) + e^{-1.5t} [\cos(2t)]' \\ &= e^{-1.5t}(-1.5) \cos 2t + e^{-1.5t}(-\sin 2t) 2 \\ &= -1.5e^{-1.5t} \cos 2t - 2e^{-1.5t}(\sin 2t) \\ y''(t) &= \left[-1.5e^{-1.5t} \cos 2t - 2e^{-1.5t}(\sin 2t) \right]' \\ &= -1.5 \left(\left[e^{-1.5t} \right]' \cos 2t + e^{-1.5t} [\cos 2t]' \right) - 2 \left(\left[e^{-1.5t} \right]' \sin 2t + e^{-1.5t} [\sin 2t]' \right) \\ &= (-1.5)^2 e^{-1.5t} \cos 2t + 2(-1.5)(-2)e^{-1.5t} \sin 2t - 2^2 e^{-1.5t} \cos 2t \\ &= -1.75e^{-1.5t} \cos 2t + 6e^{-1.5t} \sin 2t \end{aligned}$$

Now we set up a table of coefficients and terms of Equation 7.29.

$$\begin{array}{rcl} 0.02 & y''(t) & -1.75e^{-1.5t} \cos 2t + 6e^{-1.5t} \sin 2t \\ 0.06 & y'(t) & -1.5e^{-1.5t} \cos 2t - 2e^{-1.5t} \sin 2t \\ 0.125 & y(t) & e^{-1.5t} \cos 2t \end{array}$$

After substitution into Equation 7.29 the coefficients of $e^{-1.5t} \cos 2t$ and $e^{-1.5t} \sin 2t$ are

$$0.02 \times (-1.75) + 0.06 \times (-1.5) + 0.125 \times 1 = 0.0 \quad \text{and} \quad 0.02 \times 6 + 0.06 \times (-2) = 0.0$$

so

$$y(t) = e^{-1.5t} \cos(2t) \quad \text{solves} \quad 0.02y''(t) + 0.06y'(t) + 0.125y(t) = 0.$$

In the previous problem, the resistance, $r = 0.06$ was selected to make the numbers in the solution (-1.5 and 2) reasonably tractable. The resistance, $r = 0.06$ is so great, however, that the oscillations are imperceptible after only two or three oscillations, as illustrated in Figure 7.8A.

If $r = 0.002$ then the solution is

$$\begin{aligned} y(t) &= e^{-0.1t} \cos(\sqrt{6.2475}t) \\ &\doteq e^{-0.1t} \cos(2.4995t) \end{aligned}$$

and is shown in Figure 7.8B.

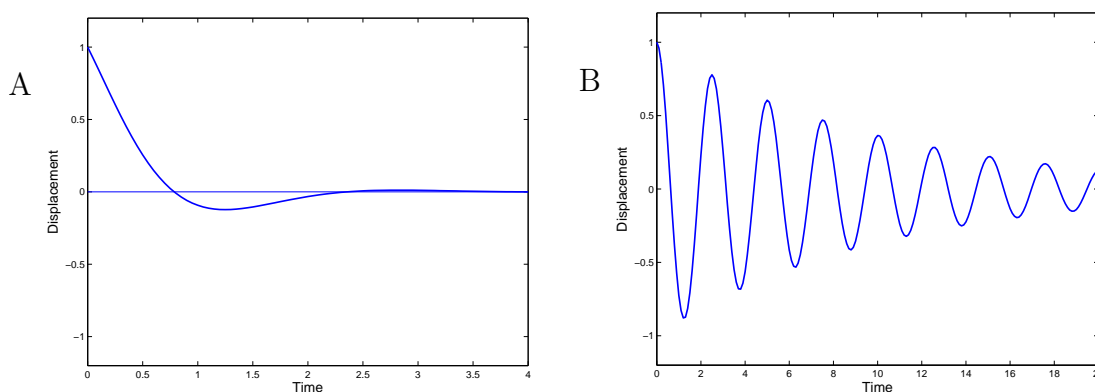

Figure 7.8: A. Graph of $y(t) = e^{-1.5t} \cos(2t)$. B. Graph of $y(t) = e^{-0.1t} \cos(2.4995t)$.

If the resistance in a vibrating system is quite large (system is buried in molasses), the system may not vibrate at all but may just ooze back to equilibrium after a displacement. Equation 7.28, $my''(t) + ry'(t) + ky(t) = 0$, may be written (divide by m)

$$y''(t) + 2by'(t) + cy(t) = 0, \quad \text{where } b = r/(2m) \text{ and } c = k/m. \quad (7.30)$$

The solutions to Equation 7.30 are **Bolts of Lightning**

$$\left. \begin{aligned} 1. \quad y(t) &= Ae^{(-b+\sqrt{b^2-c})t} + Be^{(-b-\sqrt{b^2-c})t} && \text{if } b^2 - c > 0 \\ 2. \quad y(t) &= e^{-bt}(A + Bt) && \text{if } b^2 - c = 0 \\ 3. \quad y(t) &= Ae^{-bt} \sin \sqrt{c-b^2}t + Be^{-bt} \cos \sqrt{c-b^2}t && \text{if } b^2 - c < 0 \end{aligned} \right\} \quad (7.31)$$

where A and B are constants determined by $y(0)$ and $y'(0)$. All three can be shown by substitution to solve Equation 7.30.

A system with $b^2 - c > 0$ is 'over damped' and does not oscillate. For this condition, $b = \frac{r}{2m}$, $c = \frac{k}{m}$, and

$$b^2 - c = \left(\frac{r}{2m}\right)^2 - \frac{k}{m} = \frac{r^2 - 4km}{4m^2}.$$

The condition for overdamping, no oscillation in the system, is $r^2 > 4km$ – the square of the resistance is greater than 4 times the spring constant times the mass.

If the formulas above remind you of the roots to a quadratic polynomial, it is not an accident; the connection is shown in Exercise 7.4.6.

The body suspended on a spring is easy to experiment with and typifies many oscillations that occur throughout nature. Other mechanical systems that have similar oscillations include the swinging pendulum and a rotating disc (as in the flywheel of a watch). Less apparent oscillating systems include diatomic molecules in which the distance between the two atoms oscillates very rapidly but can be approximated with the harmonic equations. In the next section we will give a simplified biological example of oscillations in predator-prey systems.

Exercises for Section 7.4, The Equation $y'' + \omega^2 y = 0$.

Exercise 7.4.1 Show that the proposed solutions satisfy the equations and initial conditions.

	Solution	Derivative Equation	Initial conditions
a.	$y(t) = 2 \sin t + \cos t$	$y'' + y = 0$	$y(0) = 1$ $y'(0) = 2$
b.	$y(t) = 4 \cos 2t$	$y'' + 4y = 0$	$y(0) = 4$ $y'(0) = 0$
c.	$y(t) = \cos 3t - \sin 3t$	$y'' + 9y = 0$	$y(0) = 1$ $y'(0) = -3$
d.	$y(t) = -20 \sin 5t + 15 \cos 5t$	$y'' + 25y = 0$	$y(0) = 15$ $y'(0) = -100$
e.	$y(t) = 4 \cos(3t + \pi/3)$	$y'' + 9y = 2$	$y(0) = 2$ $y'(0) = -6\sqrt{3}$
f.	$y(t) = \sin 2t - 2 \cos 2t$	$y'' + 4y = 0$	$y(0) = -2$ $y'(0) = 2$
g.	$y(t) = 2 \sin 3t + 3 \cos 3t$	$y'' + 9y = 0$	$y(0) = 3$ $y'(0) = 6$
h.	$y(t) = 3 \sin \pi t + 4 \cos \pi t$	$y'' + \pi^2 y = 0$	$y(0) = 4$ $y'(0) = 3\pi$

From this we conclude that

$$y(t) \quad \text{is either} \quad e^{(-b+\sqrt{b^2-c})t} \quad \text{or} \quad e^{(-b-\sqrt{b^2-c})t}$$

Both are solutions to Equation 7.30. If $b^2 - c > 0$, these are the terms in solution 1 of Equations 7.31. The exact condition $b^2 - c$ seldom occurs in nature. The issue for $b^2 - c < 0$ is how to interpret

$$e^{(-b+\sqrt{b^2-c})t} = e^{(-b+i\sqrt{c-b^2})t} = e^{-bt} e^{i\sqrt{c-b^2}t}$$

where $i = \sqrt{-1}$. **Warning: Incoming Bolt from the Blue.** The answer is that³

$$e^{i\sqrt{c-b^2}t} = \cos \sqrt{c-b^2}t + i \sin \sqrt{c-b^2}t.$$

This suggests (to some people at least) that

$$y(t) = e^{-bt} \cos \sqrt{c-b^2}t + i e^{-bt} \sin \sqrt{c-b^2}t$$

is a solution to Equation 7.30 **BANG**. Because Equation 7.30 has real number coefficients, some people think that the real and imaginary parts of $y(t)$ should each solve Equation 7.30. They do, and with tenacity you can show that they do. See Exercise 7.4.7.

Exercise 7.4.7 At least, show that

$$y(t) = e^{-bt} \cos(\sqrt{c-b^2}t)$$

solves

$$y''(t) + 2by'(t) + cy(t) = 0 \quad \text{for} \quad c - b^2 > 0$$

Exercise 7.4.8 The complete solution to Exercise 7.4.7 is given in the Solutions Section on the web. Try your hand with showing that

$$y(t) = e^{-bt} \sin(\sqrt{c-b^2}t)$$

solves

$$y''(t) + 2by'(t) + cy(t) = 0 \quad \text{for} \quad c - b^2 > 0 \quad \text{for} \quad b = 1, \quad c = 2.$$

Get a big piece of paper.

7.5 Elementary predator-prey oscillation.

Predator-prey systems are commonly cited examples of periodic oscillation in biology. Data from trapping records of the snowshoe hare and lynx gathered by trappers and sold to the Hudson Bay Company are among the most popular first introduction. Shown in Figure 7.9 is a graph showing the numbers of pelts purchased by the Hudson Bay Company for the years 1845 to 1935, and in Table 7.1 are some values read from the graph. ⁴

³We will try to convince you that this is reasonable in Chapter 12.

⁴Recent studies also demonstrate the fluctuations as shown on the web site <http://lynx.uio.no/catfolk/sp-accts.htm>. "Lynx density fluctuates dramatically with the hare cycle (Breitenmoser et al. Oikos 66 (1993), pp. 551-554). An ongoing long-term study of an unexploited population in good quality habitat in the Yukon found densities of 2.8 individuals (including kittens) per 100 km² during the hare low, and 37.2 per 100 km² during the peak (G. Mowat and B. Slough, unpubl. data)."

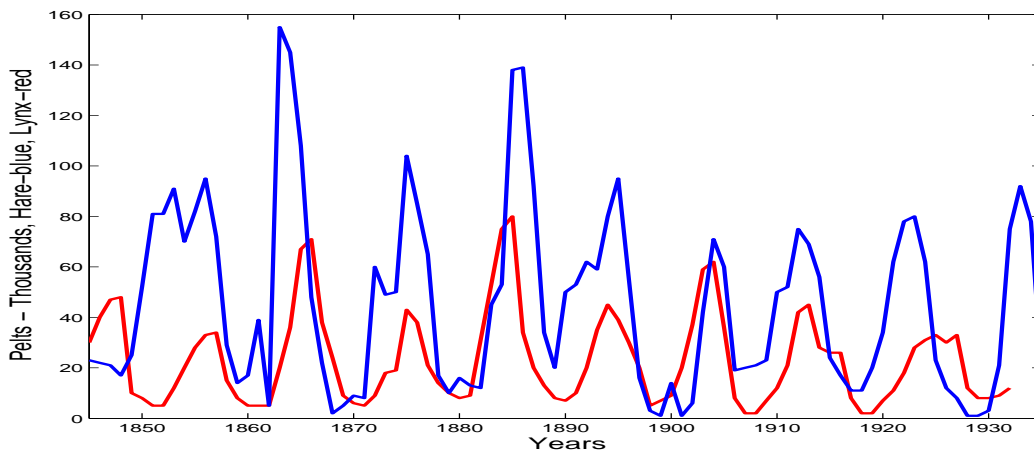

Figure 7.9: Graph of snowshoe hare and lynx pelts purchased by the Hudson Bay company for the years 1845 to 1945. Data read from Figures 3 (hare) and 16 (lynx) of D. A. MacLulich, *Fluctuations in the number of varying hare*, University of Toronto Studies, Biological Sciences, No. 43, 1937.

Table 7.1: Part of the data read from D. A. MacLulich, *ibid.*

Hare Lynx Data								
Year	Hare	Lynx	Year	Hare	Lynx	Year	Hare	Lynx
1909	23	9	1917	11	25	1925	23	40
1911	52	20	1919	20	10	1927	8	40
1913	69	40	1921	62	20	1929	1	15
1915	24	50	1923	80	25	1931	21	15

Explore 7.5.1 Do this. Complete the phase graph shown in Figure 7.5.1 using data from Table 7.1. Plot the points for the years 1915, 1917, and 1919 and draw the missing lines. ■

Explore Figure 7.5.1 Phase graph axes for hare and lynx data.

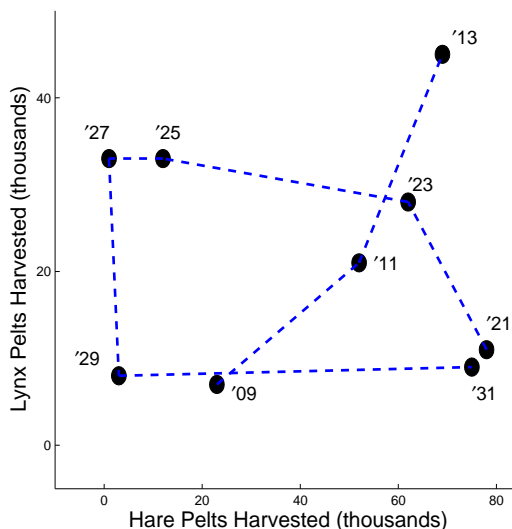

The *phase graph* that you just drew is a good way to display the interaction between two populations. You should see a general counter clockwise direction to the graph. When you are in the right-most portion of the region with large hare population, the lynx population is increasing (the curve goes up). As you get to the upper right corner the lynx population has increased sufficiently that the hare population decreases (the curve goes to the left). And the pattern continues. We will return to the lynx-hare data in Exercise 7.5.6 and find that there are exceptions to this pattern in the data.

Nils Chr. Stenseth, Wilhelm Falck, Ottar N. Bjørnstad, and Charles J. Krebs, argue in Population regulation in snowshoe hare and Canadian lynx: Asymmetric food web configurations between hare and lynx, *Proc. Nat. Acad. Sci. USA* **95** (1995), 5147-5152, that

” . . .the classic view of a symmetric hare -- lynx interaction is too simplistic. Specifically, we argue that the classic food chain structure is inappropriate: the hare is influenced by many predators other than the lynx, and the lynx is primarily influenced by the snowshoe hare.”

A Predator-Prey Model. Assume that there are two populations that interact as predator and prey in a reasonably isolated environment. Let $U(t)$ denote the number of prey and $V(t)$ denote the number of predators, and assume there are equilibrium values, U_e and V_e , so that U_e prey would provide enough food for V_e predators to just maintain their numbers (predator birth rate = predator death rate) and V_e predators would just balance the often excess birth rate of the prey (prey birth rate = prey death rate).

Shown in Figure 7.10 is an axis system where the horizontal axis is $U(t)$ and the vertical axis is $V(t)$. An equilibrium point, (U_e, V_e) , is plotted. If for some time, t , the populations are not at equilibrium, we let

$$\begin{aligned} u(t) &= U(t) - U_e \\ v(t) &= V(t) - V_e \end{aligned}$$

measure the departures from equilibrium.

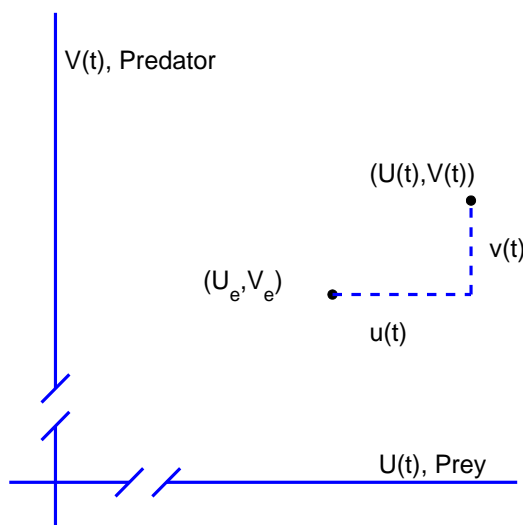

Figure 7.10: Axes for a predator prey phase graph. The gaps in the axes allow $u(t)$ to be small compared to U_e and $v(t)$ to be small compared to V_e .

Suppose the populations $U(t)$ and $V(t)$ are in equilibrium and the predator population increases (perhaps some predators immigrate into the system). The excess predators would increase capture of prey, and we could expect the prey population to *decrease*. Alternatively, if the prey should become more numerous, the predators would have a greater food supply and their numbers may *increase*.

Mathematical Model 7.5.1 For *small* deviations, $u(t)$ and $v(t)$, from equilibrium, we assume that

1. The rate of prey population *decrease*, $-U'(t)$, is proportional to the excess predator population, $v(t)$.
2. The rate of predator population *increase*, $V'(t)$, is proportional to the excess prey population, $u(t)$.

Thus from Part 1 we write

$$-U'(t) = a \times v(t) \quad \text{or} \quad U'(t) = -a v(t)$$

By the model, if the predator population exceeds equilibrium, $V(t) > V_e$ ($v(t) > 0$), then $U'(t) < 0$ and the prey population will decrease. However, if the predator population is less than normal, $V(t) < V_e$ ($v(t) < 0$), then $U'(t) > 0$ and the prey population increases. For this model, both populations must be assumed to be close to equilibrium. For example, a prey population greatly exceeding equilibrium, U_e might support a predator population slightly above equilibrium V_E and still grow.

Because $u(t) = U(t) - U_e$, $U(t) = U_e + u(t)$ and

$$U'(t) = u'(t).$$

We write

$$u'(t) = -a v(t)$$

Similarly,

$$v'(t) = b u(t)$$

Explore 7.5.2 Show that Part 2 of the Mathematical Model 7.5.1 leads to the equation

$$v'(t) = b u(t)$$

where b is a proportionality constant. ■

The two equations

$$\begin{aligned} u'(t) &= -a v(t) \\ v'(t) &= b u(t) \end{aligned}$$

describe the dynamics of the predator – prey populations. There are two unknown functions, u and v , and the equations are linked, because u' is related to v and v' is related to u . There is a general

procedure to obtain a single equation involving only u , as follows:

$$u'(t) = -a v(t) \quad \text{First Original Equation.}$$

$$[u'(t)]' = [-a v(t)]' \quad \text{Differentiate First Eq.}$$

$$u''(t) = -a v'(t)$$

$$u''(t) = -a (b u(t)) \quad \text{Substitute Second Eq.}$$

$$u''(t) + (ab) u(t) = 0$$

Now we let $\omega = \sqrt{ab}$ so that $\omega^2 = ab$ and write

$$u''(t) + \omega^2 u(t) = 0 \quad (7.32)$$

and see that it is equivalent to the dynamic equation in Equations 7.27. To complete the analogy, we need $u(0)$ and $u'(0)$.

Suppose we have a predator-prey pair of populations and because of some disturbance to the environment (rain, cold, or fire, for example) at a time, $t = 0$, the populations are at (U_0, V_0) , close to but different from the equilibrium values (U_e, V_e) . Let the departures from equilibrium be

$$u_0 = U_0 - U_e \quad \text{and} \quad v_0 = V_0 - V_e$$

Then clearly we will use $u(0) = u_0$. Also, from $u'(t) = -av(t)$ we will get $u'(0) = -av(0) = -av_0$. Thus we have the complete system

$$u(0) = u_0 \quad u'(0) = -av_0 \quad u''(t) + \omega^2 u(t) = 0 \quad (7.33)$$

From Equation 7.24 $y''(t) + \omega^2 y(t) = 0$, and its solution, Equation 7.25, $y(t) = A \sin(\omega t) + B \cos(\omega t)$, we conclude that $u(t)$ will be of the form

$$u(t) = A \sin(\omega t) + B \cos(\omega t)$$

where A and B are to be determined. Observe that

$$u'(t) = A\omega \cos(\omega t) - B\omega \sin(\omega t)$$

Now,

$$u(0) = A \sin(\omega \cdot 0) + B \cos(\omega \cdot 0) = A \cdot 0 + B \cdot 1 = B$$

$$u'(0) = A\omega \cos(\omega \cdot 0) - B\omega \sin(\omega \cdot 0) = A\omega \cdot 1 - B\omega \cdot 0 = A\omega$$

It follows that

$$B = u_0 \quad \text{and} \quad A\omega = -av_0, \quad \text{so that} \quad A = -\frac{a}{\omega} v_0$$

and the solution is

$$u(t) = -\frac{a}{\omega} v_0 \sin(\omega t) + u_0 \cos(\omega t)$$

Remembering that $\omega = \sqrt{ab}$ we may write

$$\begin{aligned}
 u(t) &= -\frac{a}{\sqrt{ab}} v_0 \sin(\sqrt{ab} t) + u_0 \cos(\sqrt{ab} t) \\
 &= -v_0 \sqrt{\frac{a}{b}} \sin(\sqrt{ab} t) + u_0 \cos(\sqrt{ab} t)
 \end{aligned}
 \tag{7.34}$$

Explore 7.5.3 Also remember the first equation, $u'(t) = -a v(t)$ and show that

$$v(t) = v_0 \cos(\sqrt{ab} t) + u_0 \sqrt{\frac{b}{a}} \sin(\sqrt{ab} t) \tag{7.35}$$

■

A little trigonometry It often happens that a periodic oscillation is the sum of two oscillations of the same frequency as in Equations 7.34 and 7.35. When that happens, the two can be combined into a single sine function. Suppose $F(t) = A \sin(\omega t) + B \cos(\omega t)$ where A , B , and ω are numbers.

Let ϕ be an angle such that

$$\begin{aligned}
 \cos \phi &= \frac{A}{\sqrt{A^2 + B^2}} \\
 \sin \phi &= \frac{B}{\sqrt{A^2 + B^2}}
 \end{aligned}$$

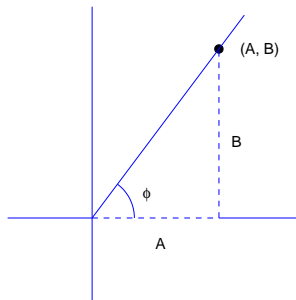

Then

$$\begin{aligned}
 F(t) &= A \sin(\omega t) + B \cos(\omega t) \\
 &= \sqrt{A^2 + B^2} \left(\frac{A}{\sqrt{A^2 + B^2}} \sin(\omega t) + \frac{B}{\sqrt{A^2 + B^2}} \cos(\omega t) \right) \\
 &= \sqrt{A^2 + B^2} (\cos \phi \sin(\omega t) + \sin \phi \cos(\omega t)) \\
 &= \sqrt{A^2 + B^2} \sin(\omega t + \phi)
 \end{aligned}$$

The last step uses $\sin(\alpha + \beta) = \sin \alpha \cos \beta + \cos \alpha \sin \beta$.

Exercises for Section 7.5, Elementary predator-prey oscillation.

Exercise 7.5.1 Suppose that $a = b = 1$ and $u_0 = 3$ and $v_0 = 4$ in the prey equation 7.34 so that

$$u(t) = -4 \sin(t) + 3 \cos(t).$$

(u_0 and v_0 are 'small' disturbances. We might suppose, for example, that the equilibrium populations are $U_e = 300$, $V_e = 200$, with 3 and 4 'small' with respect to 300 and 200).

- a. Sketch the graph of $u(t) = -4 \sin(t) + 3 \cos(t)$.
- b. Let ϕ (the Greek letter *phi*) denote the angle between 0 and 2π whose sine is $\frac{3}{5}$ and whose cosine is $\frac{-4}{5}$. Show that

$$\begin{aligned} u(t) &= 5(\cos \phi \sin t + \sin \phi \cos t) \\ &= 5 \sin(t + \phi) \end{aligned}$$

- c. Plot the graph of $5 \sin(t + \phi)$ and compare it with the graph of $-4 \sin t + 3 \cos t$.

Exercise 7.5.2 Compare Equation 7.34, $u(t) = -v_0 \sqrt{\frac{a}{b}} \sin(\sqrt{ab} t) + u_0 \cos(\sqrt{ab} t)$ for the two cases:

Case 1: $a = b = 1$ and $u_0 = 3$ and $v_0 = 4$ (in the previous problem).

Case 2: $a = 4$, $b = 1$ and $u_0 = 3$ and $v_0 = 4$

What is the biological interpretation of the change from $a = 1$ to $a = 4$?

Exercise 7.5.3 a. Find the formula for the *predator* population Equation 7.35 using the parameters, $a = b = 1$, $u_0 = 3$ and $v_0 = 4$.

- b. Let ψ (Greek letter *psi*) be the angle between 0 and 2π for which

$$\cos \psi = \frac{3}{5} \quad \text{and} \quad \sin \psi = \frac{4}{5}$$

and show that

$$v(t) = 5 \sin(t + \psi)$$

Exercise 7.5.4 Develop the *predator* harmonic equation.

- a. Examine the steps leading to Equations 7.33 and show that

$$v(0) = v_0 \quad v'(0) = b u_0 \quad v''(t) + \omega^2 v(t) = 0 \quad \text{with} \quad \omega^2 = ab \quad (7.36)$$

- b. Rewrite this system for $a = b = 1$, $u_0 = 3$ and $v_0 = 4$ and conclude that the solution is

$$v(t) = 3 \sin t + 4 \cos t$$

- c. Find a formula for $v(t)$ (predator) using the formula from Exercise 7.5.1

$u(t) = -4 \sin t + 3 \cos t$ (prey) and the equation $u'(t) = -av(t)$ ($a = 1$).

Exercise 7.5.5 The previous three exercises show that for $a = b = 1$, $u_0 = 3$ and $v_0 = 4$

$$u(t) = -4 \sin(t) + 3 \cos(t) = 5 \sin(t + 2.498)$$

$$v(t) = 3 \sin t + 4 \cos t = 5 \sin(t + 0.927)$$

Graphs of u and v are displayed in two ways in Figure 7.11. In Figure 7.11A are the conventional graphs $u(t)$ vs t and $v(t)$ vs t . In Figure 7.11B is a $V(t) = V_e + v(t)$ vs $U(t) = U_e + u(t)$ (U_e and V_e not specified).

At time $t = 0$ the excess predator and prey populations are both positive ($u_0 = 3$ and $v_0 = 4$).

- a. Replicate Figure 7.11 on your paper.

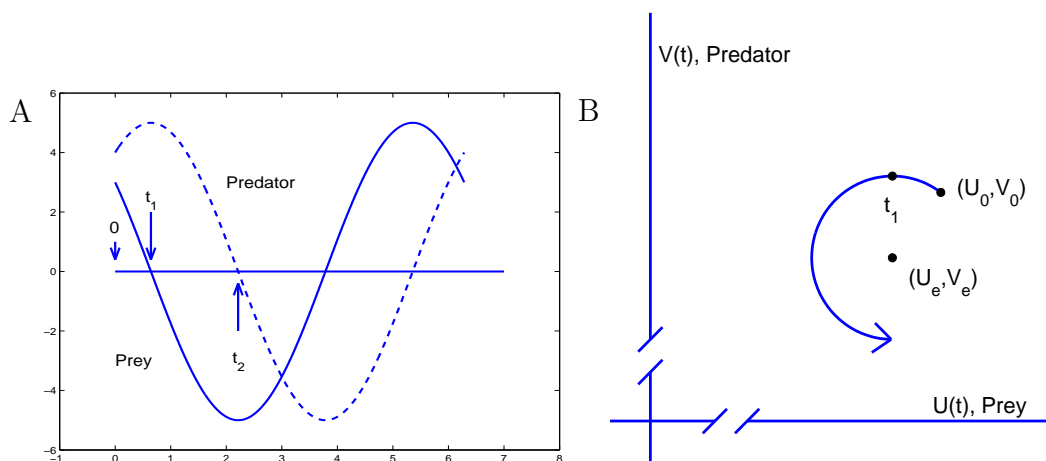

Figure 7.11: A. Conventional and B. phase graphs of predator prey functions. For scale, the distance from (U_e, V_e) to (U_0, V_0) is 5.

- b. What are $u'(0)$ and $v'(0)$?
- c. On your replica of Figure 7.11A, draw tangents to the graphs of u and v at $u(0)$ and $v(0)$.
- d. On your replica of Figure 7.11B draw a line from (U_0, V_0) to $(U_0 + u'(0), V_0 + v'(0))$. Note that the distance from (U_e, V_e) to (U_0, V_0) is 5.
- e. In Figure 7.11A, at the time $t = 0$ the prey curve has negative slope and the predator curve has positive slope. The graph in Figure 7.11B moves from (U_0, V_0) to the left (prey is decreasing) and upward (predator is increasing).
 1. Discuss the dynamics of the predator and prey populations at time t_1 .
 2. Discuss the dynamics of the predator and prey populations at time t_2 marked on Figure 7.11A and mark the corresponding point on Figure 7.11B.
- f. Show that

$$(u(t))^2 + (v(t))^2 = u_0^2 + v_0^2$$

What is the significance of this equation?

Exercise 7.5.6 J. D. Murray *Mathematical Biology*, Springer, New York, 1993, p 66 observes an exception to the phase graph for the Lynx-Hare during years 1874-1904. The data are shown in Figure 7.12 along with a table of part of the data.

- a. Read data points in Figure 7.12 for the years 1887 and 1888.
- b. Use the data in Table 7.2 and your two data points to make a phase plot for the years 1875 - 1888.
- c. Discuss the peculiarity of this predator-prey phase plot.

Murray notes that the 1875 - 1887 data seems to show that the 'hares are eating the lynx', and cites some explanations that have been offered, including a possible hare disease that could kill the

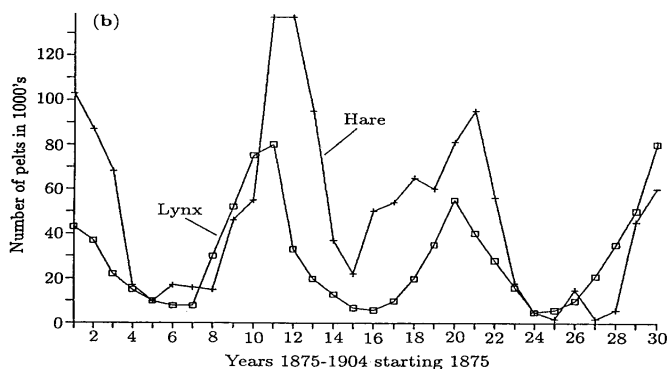

Figure 7.12: Snowshoe Hare and Lynx data for the years 1874-1904.

Table 7.2: Lynx-Hare data read Figures 3 (hare) and 16 (lynx) of D. A. MacLulich, Fluctuations in the number of varying hare, University of Toronto Studies, Biological Sciences, No. 43, 1937.

Hare Lynx Data Read From the Graph								
Year	Hare	Lynx	Year	Hare	Lynx	Year	Hare	Lynx
1875	104	43	1879	10	10	1883	45	53
1876	85	38	1880	16	8	1884	53	75
1877	65	21	1881	13	9	1885	138	80
1878	17	14	1882	12	31	1886	139	34

lynx (no such disease is known) and variation in trapping practice in years of low population density.

Exercise 7.5.7 For the algebraically robust. For Equations 7.34 and 7.35,

$$u(t) = -v_0 \sqrt{\frac{a}{b}} \sin(\sqrt{ab} t) + u_0 \cos(\sqrt{ab} t) \quad v(t) = v_0 \cos(\sqrt{ab} t) + u_0 \sqrt{\frac{b}{a}} \sin(\sqrt{ab} t)$$

show that

$$\sqrt{\frac{b}{a}} (u(t))^2 + \sqrt{\frac{a}{b}} (v(t))^2 = \sqrt{\frac{b}{a}} (u_0)^2 + \sqrt{\frac{a}{b}} (v_0)^2.$$

What is the significance of this equation?

Exercise 7.5.8 Suppose the prey population may be affected by over crowding even with low predator presence.

Mathematical Model 7.5.2 For *small* deviations, $u(t)$ and $v(t)$, from equilibrium, we assume that

1. The prey population *decreases*, $U'(t)$ is negative, when there is excess prey population $u(t)$ and when there is excess predator population, $v(t)$.
2. The predator population *increase*, $V'(t)$, is proportional to the excess prey population, $u(t)$.

Step 1 can be interpreted at least two ways:

- A. $-U'(t)$ could be proportional to the *product* of $u(t)$ and $v(t)$, or
- B. $-U'(t)$ could be proportional to the *sum* of $av(t) + cu(t)$ where a and c are numbers.

Both interpretations are relevant. Here we choose interpretation B. Step 2 is the same as for Model 7.37 and write

$$-U'(t) = av(t) + cu(t)$$

$$V'(t) = bu(t)$$

Again $U'(t) = u'(t)$ and $V'(t) = v'(t)$, so that

$$\begin{aligned} u'(t) &= -av(t) - cu(t) \\ v'(t) &= bu(t) \end{aligned} \tag{7.37}$$

- a. Use Equations 7.37 to show that

$$v''(t) + cv'(t) + abv(t) = 0 \tag{7.38}$$

Hint: Compute

$$[v'(t)]' = [bu(t)]', \quad \text{use} \quad u'(t) = -av(t) - cu(t) \quad \text{and} \quad bu(t) = v'(t)$$

- b. Equation 7.38 may be compared with Equation 7.28 for damped harmonic motion (harmonic motion with resistance). For $a = 2.02$, $b = 0.5$, and $c = 0.2$ the equation becomes

$$v''(t) + 0.2v'(t) + 1.01v(t) = 0 \tag{7.39}$$

Show that

$$v(t) = e^{-t/10} \sin t$$

is a solution to this equation.

- c. Show that if $v(t) = e^{-t/10} \sin t$ then

$$u(t) = 2e^{-t/10} \cos t - 0.2e^{-t/10} \sin t$$

- d. Show that

$$u^2 + 0.4uv + 4.04v^2 = 4e^{-t/5}$$

- e. Plot a graph of $u(t)$ vs $v(t)$. It is of interest that $u^2 + 0.4uv + 4.04v^2 = 4$ is an ellipse in the u - v plane.

7.6 Periodic systems.

Many biological and physical systems exhibit periodic variation governed by feed back of information from the state of the system to the driving forces of the system. An excess of predators (state of the system) drives down (driving force) the prey population. An elongation of a spring (state of the system) causes (driving force) the suspended mass to move up toward the equilibrium position.

Examples of periodically varying feed back systems are presented. Exercises are distributed through the three subsections.

Explore 7.6.1 Chamelons are a group of lizards that change their color to match the color of their environment. What is the color of a chameleon placed on a mirror? ■

7.6.1 Control switches.

Some street lights and household night lights have photosensitive switches that turn the lights on at sunset and turn them off at sunrise. In Figure 7.6.1 is a household night light with a photosensitive switch and a mirror. The mirror can be adjusted so that the light from the bulb is reflected back to the photosensitive switch. What will be the behavior of the switch at night? With sunlight shining on it?

Explore 7.6.2 You will find it interesting to perform an experiment. In a dark room, hold a mirror about 3 inches from a night light so that it reflects light from a night light back to the photosensitive switch. Move the mirror about 8 inches from the night light and note the change in the activity of the night light. ■

We propose the following mathematical model for the system.

Mathematical Model 7.6.1 Night lights. I There is a voltage in the photosensitive switch that increases at a rate proportional to the intensity of light striking the switch and the intensity of the light leaving the bulb decreases at a rate proportional to the voltage.

The intensity of the reflected light that strikes the switch is proportional to the intensity of the light leaving the bulb and inversely proportional to the square of the distance from the bulb to the mirror.

Exercise 7.6.1 a. The first paragraph should remind you of a predator prey system. Assuming so, is the voltage the predator or the prey?

b. Write equations for the mathematical Model 7.6.1.

Figure for Exercise 7.6.1 A night light with a mirror that can be positioned to reflect light back to the photosensitive switch.

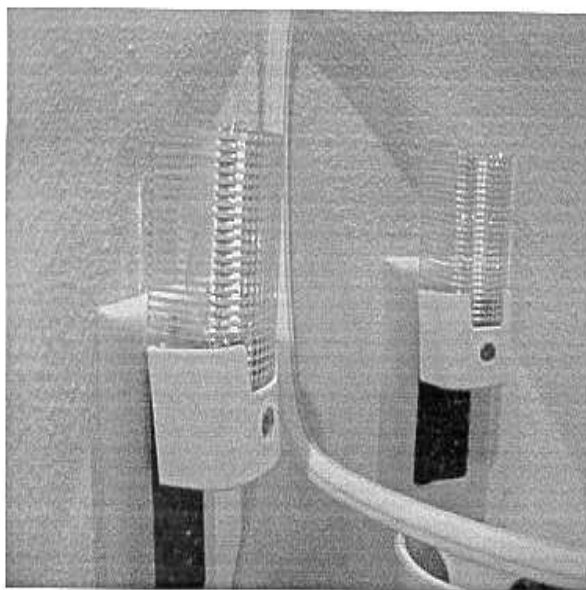

Exercise 7.6.2 We propose a second mathematical model for night lights.

Mathematical Model 7.6.2 Night lights. II There is a voltage in the photosensitive switch that increases at a rate proportional to the intensity of light striking the switch and dissipates at a constant rate when no light strikes the switch. The light is either on or off; it turns on when the voltage falls below a certain threshold and turns off when the voltage exceeds another threshold.

The intensity of the reflected light that strikes the switch is proportional to the intensity of the light leaving the bulb and inversely proportional to the square of twice the distance from the bulb to the mirror.

Let $v(t)$ be the voltage in the photosensitive switch at time t and $i(t)$ be the illumination striking the photosensitive switch at time t .

a. Write an equation descriptive of

There is a voltage in the photosensitive switch that increases at a rate proportional to the intensity of light striking the switch and dissipates at a constant rate when no light strikes the switch.

b. Because the light is either on or off, it is easiest to treat the mathematical model 7.6.2 Night Light II as a discrete system. Choose an increment time $\delta > 0$ and for $k = 0, 1, 2, \dots, N$, let

$$v_k = v(k \times \delta) \quad \text{and} \quad i_k = i(k \times \delta),$$

and assume that

$$v'(k \times \delta) \doteq \frac{v_{k+1} - v_k}{\delta}.$$

Write a discrete analog of your previous equation

c. Let $v_{on} < v_{off}$ be threshold values and $sw(v)$ be a 'switch' function defined by

$$sw(v(t)) = \begin{cases} 1 & \text{for } v(t) \leq v_{on} \\ (1 + \text{sign}(v'(t)))/2 & \text{for } v_{on} < v(t) < v_{off} \\ 0 & \text{for } v_{off} \leq v(t) \end{cases}$$

Figure 7.6.2 illustrates the solutions to the equation

$$\begin{aligned} v_0 &= 1.25 \\ i_0 &= 0 \\ v_{k+1} &= v_k + (2 \times i_k - 1) \times \delta \\ i_{k+1} &= sw(v_k), \end{aligned} \tag{7.40}$$

where $v_{on} = 1.5$ and $v_{off} = 2.5$, and $N = 230$.

If you have adequate computing, replicate Figure 7.6.2. Else, compute (v_1, i_1) , (v_2, i_2) , (v_3, i_3) , (v_4, i_4) , and (v_5, i_5) .

Figure for Exercise 7.6.2 Solutions to Equations 7.40. Light intensity is the solid curve and voltage is the dashed curve.

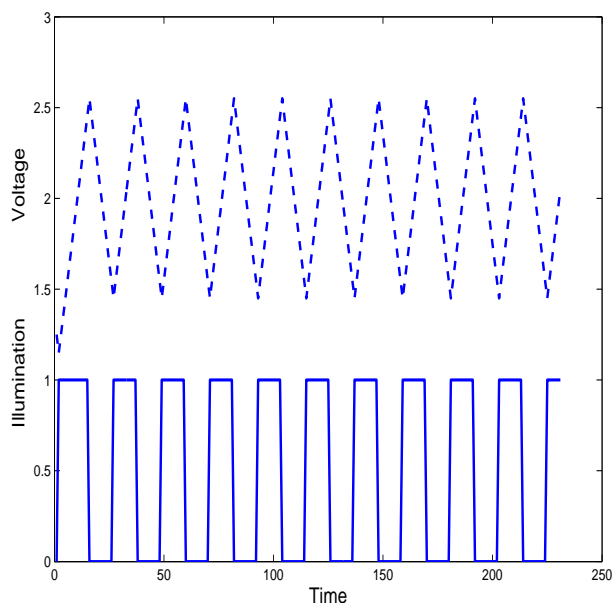

Exercise 7.6.3 Thermostats control the furnaces on houses. They turn the furnace on when the temperature falls below a temperature set by the home owner and turn the furnace off when the temperature exceeds a temperature set by the home owner.

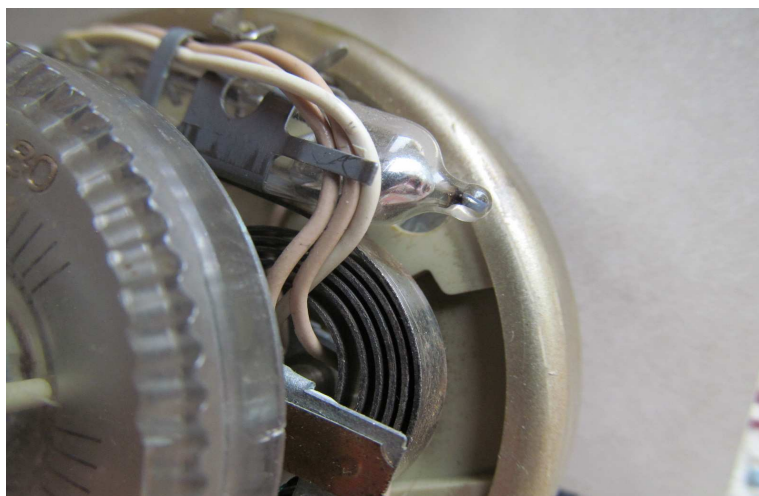

Figure 7.13: Inside view of a Honeywell thermostat. The coil is expanded and the mercury is at the right end of the tube and does not connect the wires at the opposite end.

The control system of a thermostat is shown in Figure 7.13. There is a bi-metallic coil that expands or contracts according to the temperature of the coil. There is a small glass tube containing a dollop of mercury at the top of the coil that tilts as the coil expands or contracts. Three wires are at one end of the tube. When the temperature is "low" the tube tilts so that the mercury completes the connection between the two wires. When the temperature is "high" the tube tilts so that the mercury is at the opposite end of the tube from the wires and the connection is broken. As the temperature moves between the "low" and "high" temperatures the mercury slowly moves towards the center of the tube until a threshold angle is reached and it flows to the opposite end of the tube and either opens or closes the connection between the two wires.

- Write a mathematical model descriptive of temperature inside a house when the furnace is

not running and the outside temperature is below the temperature inside the house. You may wish to review Exercises 1.11.5 and 5.5.23 and 7.6.2.

- b. Write equations that describe your mathematical model.
- c. Draw a graph descriptive of the temperature inside a house in northern Minnesota for one day in January.
- d. Draw a graph descriptive of the temperature inside a house in Virginia for one day in January.

7.6.2 Earthquakes.

The San Andreas fault in California is an 800 mile zone of contact between two tectonic plates, with the continental crust on the east and the oceanic crust on the west. As the oceanic crust moves north and rubs against the continental crust, at some points along the fault faces of the crust lock together and the earth bends — until a threshold distortion is surpassed. Then the faces of the crusts abruptly slide past one another sending shock waves out across the earth, and the crusts returns to a more relaxed condition. The maximum slippage recorded between two crusts is a 21 foot displacement of a road during the 1906 earthquake in the San Francisco region.



Figure 7.14: San Andreas Fault. Photograph from Wallace, Robert E., ed., 1990, The San Andreas fault system, California: U.S. Geological Survey Professional Paper 1515, 283 p. [<http://pubs.usgs.gov/pp/1988/1434/>].

A simple model of this system was described by Steven Gao of Kansas State University. Consider a body of mass m on a horizontal platform, a spring with one end attached to the body and the other end moving along the platform at a rate v . There are two frictions associated with the body, the starting friction, F_{start} , and the sliding friction, F_{slide} ,

$$F_{slide} < F_{start}.$$

If the body is not moving relative to the platform, F_{start} is the force required to initiate movement. If the body is in motion along the platform, F_{slide} is the force required to continue motion.

The spring has a spring constant k ; an elongation of length E in the spring causes a force of magnitude $k \times E$ on the body. Let L be the length of the spring when there is no tension on the spring.

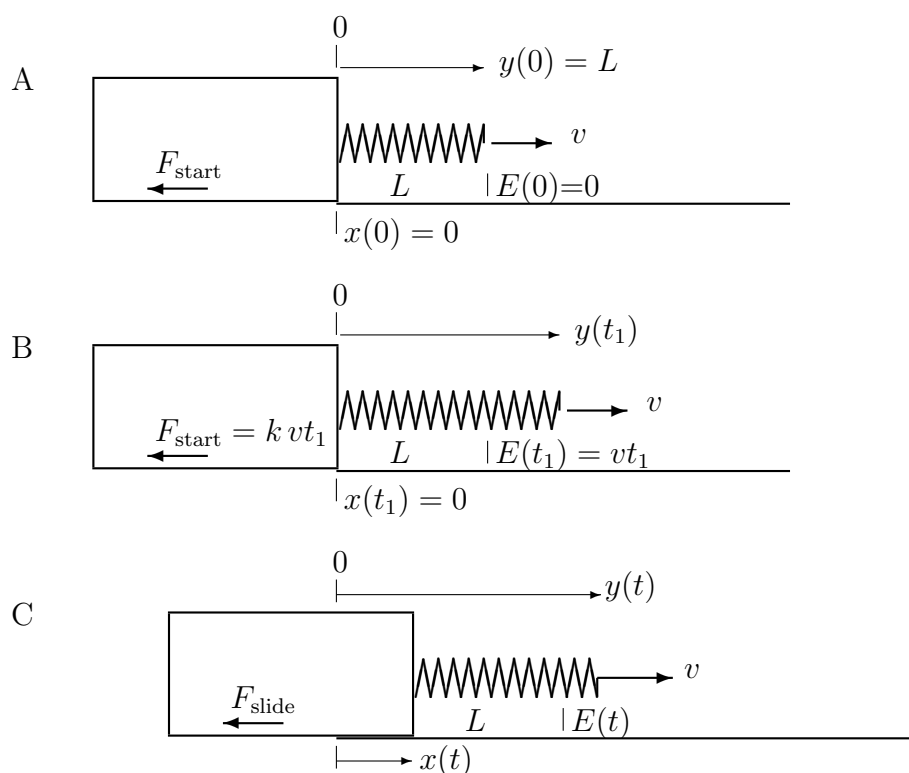

Figure 7.15: A. Initial condition of a block with spring pull and starting friction. B. The block will first move at time t_1 when the force of the spring elongation, kvt_1 , exactly matches the starting friction, F_{Start} . C. Motion of a block with spring pull and sliding friction.

In this model, the horizontal platform is the continental crust and the body and spring are the oceanic crust.

Mark a point on the platform as the zero point, let $x(t)$ be the distance from zero to the forward face of the body, and let $y(t)$ be the distance from zero to the forward end of the spring. Let $E(t)$ be the extension of the spring.

Assume the initial conditions:

$$x(0) = 0, \quad y(0) = L, \quad \text{so that} \quad E(0) = 0$$

Exercise 7.6.4 1. What is $y'(t)$ for all t ?

2. Write a formula for $y(t)$.
3. The force of the spring on the body will be $k \times E(t) = k (y(t) - L - x(t))$. What is the force at time $t = 0$?
4. At what time, t_1 , will the body first move (will the force on the body = F_{start})?

During the first motion of the body, the net force, F , on the body will be

$$\begin{aligned} F &= k (y(t) - L - x(t)) - F_{slide} \\ &= k (L + vt - L - x(t)) - F_{slide} \\ &= k (vt - x(t)) - F_{slide} \end{aligned}$$

Newton's second law of motion gives

$$F = m a = m x'',$$

so that

$$m x'' = k (vt - x(t)) - F_{slide}$$

or

$$x'' + \omega^2 x = \frac{k}{m} vt - \frac{F_{slide}}{m} \quad \omega^2 = \frac{k}{m} \quad (7.41)$$

Let t_1 be the time at which the first motion starts. Then

$$x(t_1) = 0 \quad (7.42)$$

$$x'(t_1) = 0 \quad (7.43)$$

Reader Beware: Incoming Lightning Bolt! In Chapter 17, Second order and systems of two first order differential equations, you will learn how to find the function, $x(t)$, that satisfies equations 7.41, 7.42, and 7.43:

$$\begin{aligned} x(t) &= \frac{-F_{start} + F_{slide}}{k} \cos(\omega (t - t_1)) \\ &\quad - \frac{v}{\omega} \sin(\omega(t - t_1)) + vt - \frac{F_{slide}}{k} \end{aligned} \quad (7.44)$$

Exercise 7.6.5 Show that the function, $x(t)$ defined in Equation 7.44 satisfies equation 7.42, 7.43, and 7.41.

Exercise 7.6.6 Equation 7.44 is valid until $x'(t)$ next equals to zero. Use the parameters

$$F_{start} = 5, \quad F_{slide} = 4, \quad k = 1, \quad v = 0.1, \quad \text{and} \quad m = 1$$

and draw the graph of x . An elongation of $E = F_{start}/k = 5$ initiates motion at time $t_1 = F_{start}/kv = 50$, and $\omega^2 = k/m = 1$ with these parameters. Find the time and value of x at which $x' = 0$.

Using the parameters of the previous exercise, the body moved 2.33 units in a time of 3.33 units; the velocity of the forward end of the spring is 0.1 so the forward end moved 0.33 units during the motion. At the time the body stopped moving, the elongation of the spring was $5 - 2.33$

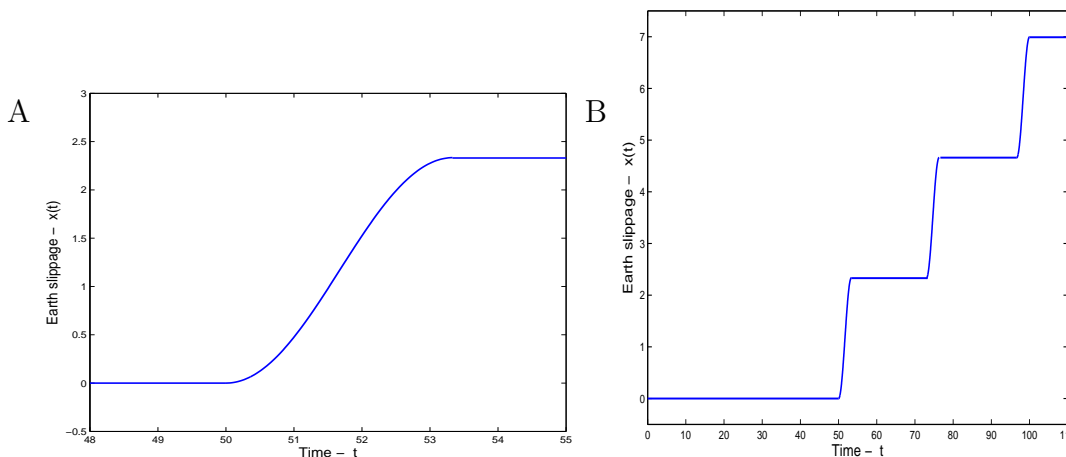

Figure 7.16: A. Graph of the first slippage, $x(t)$, for Equation 7.44 and the parameter values of Exercise 7.6.6. B. Graph of three slippage events with quiescence between events.

Table 7.3: Significant earthquakes in the Los Angeles, CA area 1920 - 1994, <http://pasadena.wr.usgs.gov/info/index.html>

Year	Magnitude	Year	Magnitude	Year	Magnitude	Year	Magnitude
1920	4.9	1941	4.8	1973	5.2	1989	5.0
1930	5.2	1952	5.2	1979	5.2	1990	5.3
1933	6.4	1969	5.1	1981	6.0	1991	5.8
1938	5.2	1970	5.2	1987	5.9	1994	6.7
1941	4.8	1971	6.7	1988	5.0		

+ 0.33 = 3. After 20 more time units, the elongation will again reach 5 and the motion of the body will be repeated. A graph of the motion of the body is shown in Figure 7.16

The model we describe exhibits periodic ‘relief’ of the tension in the spring. Do earth quakes exhibit periodicity in their recurrence? If so it would greatly simplify the prediction of earth quakes! The dates of significant earth quakes and their magnitudes (4.8 - 6.7) that have occurred in the Los Angeles area fault since 1920 are shown in Table 7.3. You may search the table for periodicity. As emphasized by Dr. Gao, the fault is a complex system; many small earthquakes occur every month; relief in on section may increase strain at other points. His model does, however, suggest the nature of the mechanics of an earth quake. The U.S. Geological Survey web site, <http://pubs.usgs.gov/gip/earthq3/>, contains very interesting discussion of earthquakes.

7.6.3 The circadian clock.

Exciting current studies in molecular biology and genetics are illuminating the molecular and neural systems that control the daily rhythm of our lives, wakes us up in the morning, puts us to sleep at night, and causes ‘jet lag’ when we travel to different time zones or even without travel when daylight savings time is initiated in the Spring. The molecular clocks that control circadian rhythms have been identified in fruit flies, mammals, *Neurospora* (fungus), *Arabidopsis* (plant), and cyanobacteria. They are markedly similar and It appears that there has been multiple evolution of

the same basic mechanism. The *Neurospora* mechanism is described here from a review, J. C. Dunlap, *Ann. Rev. Genet.* **30** (1996), 579.

In *Neurospora*, there is a gene, *frq* (frequency), that is transcribed into a mRNA also called *frq* that codes for a protein, denoted FRQ. FRQ stimulates metabolic activities associated with daylight. A high level of FRQ also acts to shut off transcription of the gene *frq* so that the concentration of mRNA *frq* decreases. There is a potentially oscillating system: *frq* increases and causes an increase in FRQ that causes a decrease in *frq* so that FRQ decreases (is no longer transcribed from *frq* and is naturally degraded as are most proteins). However, there is resistance in the system and periodic stimulus from daylight is necessary to keep the system active and to entrain it to the daily 24 hour rhythm.

Circadian time (CT) begins with 0 at dawn, 6 is noon, 12 is dusk, 18 is midnight, and $24 = 0$ is dawn. The *Neurospora* circadian cycle begins at midnight, CT 18, at which time both *frq* and FRQ are at low levels, but transcription of *frq* begins, say at a fixed rate. After a 3 hour time lag translation of *frq* to create FRQ begins. At dawn, CT 0, there is a marked increase in transcription of *frq* and an almost immediate increase of translation to FRQ. A high level of FRQ inhibits the transcription of *frq* and *frq* levels peak during CT 2 - 6 and declines steadily until CT 18. FRQ levels peak during CT 6 - 10 and also decline until CT 18 (the protein FRQ is constantly degraded and with decreasing levels of *frq* the turnover is more rapid than production).

- Exercise 7.6.7**
- Draw a graph representative of the concentration of the mRNA *frq* as a function of time (use CT).
 - Draw a graph representative of the concentration of the protein FRQ as a function of time (use CT).
 - Draw a phase diagram with concentration of *frq* on the horizontal axis and concentration of FRQ on the vertical axis covering one 24 hour period.

Chapter 8

Applications of Derivatives.

Where are we going?

The derivative is a powerful tool for analysis of curves, selection of optimal parameter values, and measuring the influence of one variable on another. If you are a doctor in the midst of a flu epidemic, you know that the number of newly infected people is increasing every day. What is important to you today is whether the rate at which newly infected people appear is increasing suggesting a future similar to A or is slowing down as in B. B is better.

If the graphs represent the daily weight of an infant, however, B could be a signal of inadequate nutrition or disease. A is better.

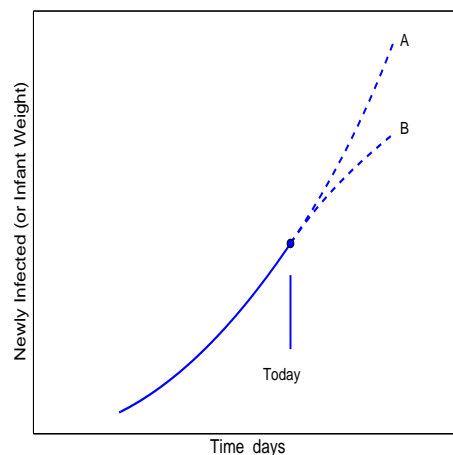

8.1 Some geometry of the derivative

It is often important to know whether a population, atmospheric CO₂ concentration, average temperature, white blood count, number of flu cases, etc. is increasing or decreasing with time or location, and whether the rate of increase is itself increasing or decreasing.

The relation between positive, negative, and zero slopes and increasing, nondecreasing, nonincreasing, decreasing, highest points and lowest points is examined. The graph in Figure 8.1 illustrates three of these concepts. The graph has positive slope at every point, and is increasing. The slopes increase between points A and B, and *the tangents lie below the graph*. The slopes decrease between points C and D, and the tangents lie *above* the graph.

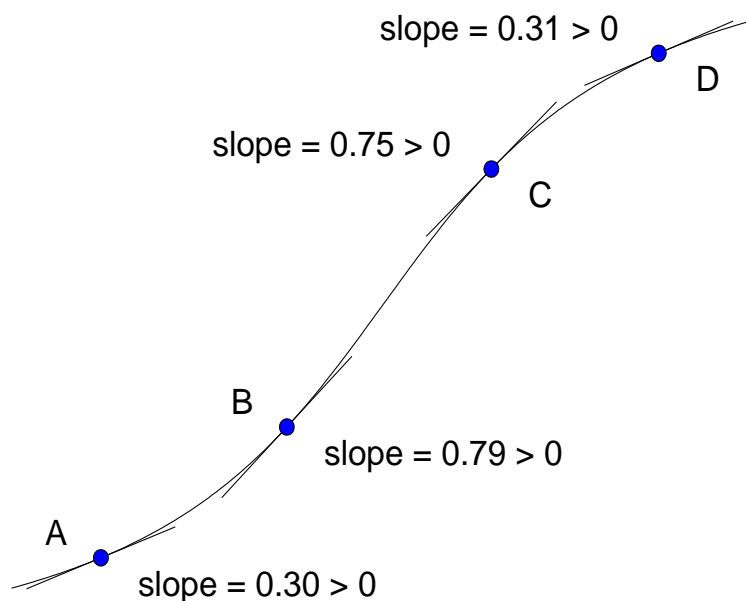

Figure 8.1: Graph of an increasing function. The slope is positive at every point. Between points A and B the slopes **increase** from 0.3 to 0.79 and the tangents lie **below** the curve. Between point C and D the slopes **decrease** from 0.75 to 0.31 and the tangents lie **above** the curve.

In Definition 3.1.3, the derivative $P'(a)$ of a function $P(t)$ at a number a is the slope of the tangent to the the graph of P at the point $(a, P(a))$.

The next definition of *increasing function* should agree with your intuitive notions that a population is growing, or that a chemical is accumulating, or a that temperature is increasing.

Definition 8.1.1 A function P , is said to be **increasing** if for any two numbers, a and b in the domain of P ,

$$\text{if } a < b, \quad \text{then } P(a) < P(b).$$

Explore 8.1.1 Do this.

1. Only one of the graphs shown in Figure 8.1.1 is the graph of an increasing function. Which one?
2. For the function that is not increasing, explain why it fails to satisfy Definition 8.1.1.
3. Does every tangent to the graph of the increasing functions have positive slope?

■

Explore Figure 8.1.1 Graphs of an increasing function and a function that is not increasing.

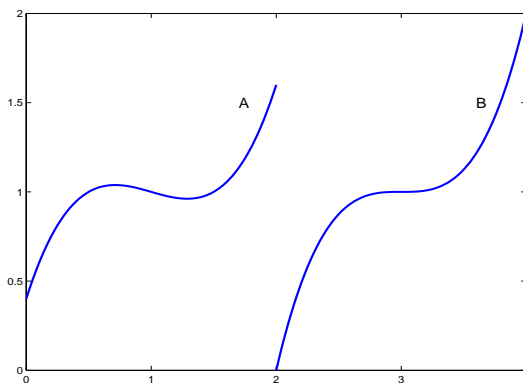

It may seem intuitive that if a population is growing then the growth rate is always positive. This is not true – as you may have found out from the preceding Explore 8.1.1 and is shown in the next example.

Example 8.1.1 A graph of the cubic function, $P(t) = t^3$ is shown in Figure 8.1.1.1 (and in Explore Figure 8.1.1), together with the tangent to the graph at the point $(0,0)$. $P(t) = t^3$ is an increasing function: If $a < b$ then $a^3 < b^3$.

However, the tangent to the graph of P at $(0,0)$ is horizontal. $P'(0) = 3t^2|_{t=0} = 3 \cdot 0^2 = 0$. So that P' is not everywhere positive.

Figure for Example 8.1.1.1 The graph of $y = t^3$ and its tangent at $(0,0)$.

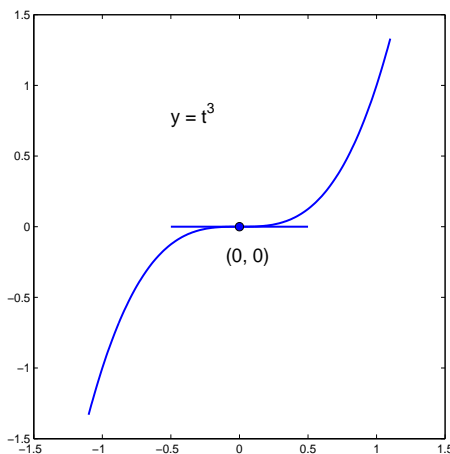

The previous example is a bit of a nuisance. We would like increasing function and positive slope to be equivalent, and they are not. The fall back position is to define *non-decreasing* functions which will be found to be equivalent to *non-negative* slopes.

Definition 8.1.2 A function P , is said to be **non-decreasing** if for any two numbers a and b in the domain of P ,

$$\text{if } a < b, \quad \text{then } P(a) \leq P(b).$$

Note: Compare

$$\text{If } a < b \quad \text{then } P(a) < P(b). \quad \text{Increasing}$$

and

$$\text{If } a < b \quad \text{then } P(a) \leq P(b). \quad \text{Non-decreasing}$$

Every increasing function is also non-decreasing, but, for example, a constant function, $P(t) = C$, is non-decreasing but is not an increasing function.

Explore 8.1.2 Suppose P is a non-decreasing function.

- Argue that every difference quotient, $\frac{P(b)-P(a)}{b-a}$, is greater than or equal to zero. (Consider two cases: $a < b$ and $b < a$.)
- Suppose a is a number for which $P'(a)$ exists. Argue that $P'(a)$ is not a negative number. ■

Thus if P is a non-decreasing function, then $P'(t) \geq 0$ for all t (P' is nonnegative). This result is often used in reverse:

If $P'(t) \geq 0$ for all t then P is non-decreasing.

That is a true statement and is Theorem 12.2.1 of Section 12.2. We use it in this chapter, but we have not yet shown it to be true.

The two results may be written as a theorem to be proved in Section 12.2.

Theorem 8.1.1 Suppose P is a function defined on an interval $[a, b]$. Then P is nondecreasing on $[a, b]$ if and only if $P'(t) \geq 0$ for all t in $[a, b]$.

Explore 8.1.3 Write definitions of *decreasing* function and of *non-increasing* function and state a theorem about nonincreasing functions analogous to Theorem 8.1.1. ■

We also state a related theorem to be proved in Section 12.2:

Theorem 8.1.2 Suppose P is a continuous function defined on an interval $[a, b]$. If $P'(t) > 0$ for $a < t < b$ then P is increasing on $[a, b]$.

That the converse of this theorem is not a theorem follows from the example of $P(t) = t^3$, $[a, b] = [-1, 1]$.

Example 8.1.2 The natural logarithm, \ln , is an increasing function.

By the previous theorem, \ln is increasing if \ln' is positive. $\ln x$ is only defined for $x > 0$, and

$$[\ln x]' = \frac{1}{x} > 0 \quad \text{for} \quad x > 0$$

■

Explore 8.1.4 Is it true that \ln is a nondecreasing function?

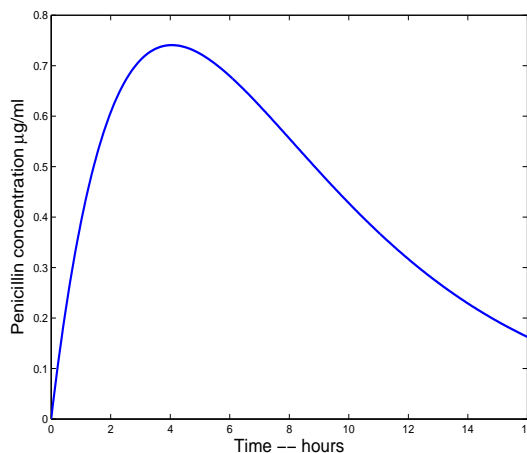

Figure 8.2: The graph of $C(t) = 5e^{-0.2t} - 5e^{-0.3t}$ showing a period of increasing blood penicillin concentration followed by a period of decreasing blood penicillin concentration.

Example 8.1.3 Following ingestion of a penicillin pill, penicillin is absorbed from the intestine into the blood stream, the concentration, C , of penicillin in the blood is approximated by the function

$$C(t) = 5e^{-0.2t} - 5e^{-0.3t} \quad \frac{\mu\text{g}}{\text{ml}}$$

where t is time measured in hours (Figure 8.2).

Problem: During what time interval is the concentration of penicillin in the blood increasing? What is the maximum concentration of penicillin?

Solution: Compute

$$\begin{aligned} C'(t) &= [5e^{-0.2t} - 5e^{-0.3t}]' \\ &= 5e^{-0.2t}(-0.2) - 5e^{-0.3t}(-0.3) \\ &= 5e^{-0.3t}(-0.2e^{0.1t} + 0.3) \end{aligned}$$

Because $5 > 0$ and $e^{-0.3t} > 0$ for all t , $C'(t)$ is positive if $-0.2e^{0.1t} + 0.3$ is positive. The following inequalities are equivalent:

$$\begin{aligned} -0.2e^{0.1t} + 0.3 &> 0 \\ 1.5 &> e^{0.1t} \\ \ln 1.5 &> \ln(e^{0.1t}) && (\ln t \text{ is an increasing function.}) \\ \ln 1.5 &> 0.1t \\ 10 \ln 1.5 &> t \end{aligned}$$

We can conclude that $C'(t)$ is positive if $0 \leq t < 10 \ln 1.5 \doteq 4.05$. Thus serum penicillin is increasing for about four hours after ingestion of the penicillin pill into the intestinal track. ■

You were asked in Explore 8.1.3 to define **decreasing** and **nonincreasing**.

As in Explore 8.1.2, you can show that if P is nonincreasing, then $P'(t) \leq 0$. By considering $Q(t) = -P(t)$, it follows from Theorem 8.1.1 that if $P'(t) \leq 0$ then P is nonincreasing, and from Theorem 8.1.2 that if $P'(t) < 0$ for $a < t < b$ then P is decreasing on $[a, b]$.

From the preceding example of blood penicillin concentration, with $C'(t) = 5e^{-0.3t}(-0.2e^{0.1t} + 0.3)$ we observe that

$$5 > 0 \quad e^{-0.3t} > 0 \quad \text{for all } t \text{ and} \quad -0.2e^{0.1t} + 0.3 < 0 \quad \text{for } 10 \ln 1.5 < t$$

and we conclude that penicillin concentration is decreasing for $t \geq 10 \ln 1.5 \doteq 4.05$ hours.

Because the penicillin concentration is increasing during 0 to $10 \ln 1.5$ hours and decreasing afterward, the maximum concentration must occur at $10 \ln 1.5$ hours. That maximum concentration is $C(10 \ln 1.5)$ and

$$\begin{aligned} C(10 \ln 1.5) &= 5e^{-0.2 \times 10 \ln 1.5} - 5e^{-0.3 \times 10 \ln 1.5} \\ &= 5e^{-2 \ln 1.5} - 5e^{-3 \ln 1.5} \\ &= 5 \left(e^{\ln 1.5} \right)^{-2} - 5 \left(e^{\ln 1.5} \right)^{-3} \\ &= 5 \frac{1}{1.5^2} - 5 \frac{1}{1.5^3} \doteq 0.74074. \end{aligned}$$

Hence, the maximum concentration is approximately $0.74 \mu\text{g/ml}$.

Explore 8.1.5 Draw the tangent to the graph in Figure 8.2 at the point $(4.05, 0.74)$. ■

8.1.1 Convex up, concave down, and inflection points.

Now we examine when P' is increasing (signaled by $P'' > 0$). In such regions, the graph of P is *convex up* or simply *convex*. Similarly, when $P'' < 0$, P' is decreasing and the graph of P is *concave down* or simply *concave*. Information provided by the second derivative is illustrated by the graph of $P(x) = x(x-2)(x-4) = x^3 - 7x^2 + 10x$ in Figure 8.3.

$$\begin{aligned} P(x) &= x^3 - 7x^2 + 10x, & P'(x) &= 3x^2 - 14x + 10 \\ P''(x) &= 6x - 14 & &= 6(x - 7/3) \end{aligned}$$

In Figure 8.3, the slope of P decreases on the interval $[A, a]$. The slope of P increases on the interval $[b, B]$.

If $x < 7/3$, $P''(x) < 0$, and $P'(x)$ is decreasing and $P(x)$ is concave down.

If $x > 7/3$, $P''(x) > 0$, and $P'(x)$ is increasing and $P(x)$ is convex up.

The tangents to the graph at A and a lie above the graph except at the points of tangency, consistent with P being concave down on $x < 7/3$. The tangents to the graph at b and B lie below the graph except at the points of tangency, consistent with P being convex up on $7/3 < x$. The point at $(7/3, 19/3)$ is an inflection point. $P''(7/3) = 0$ and the tangent at $(7/3, 19/3)$ crosses the graph.

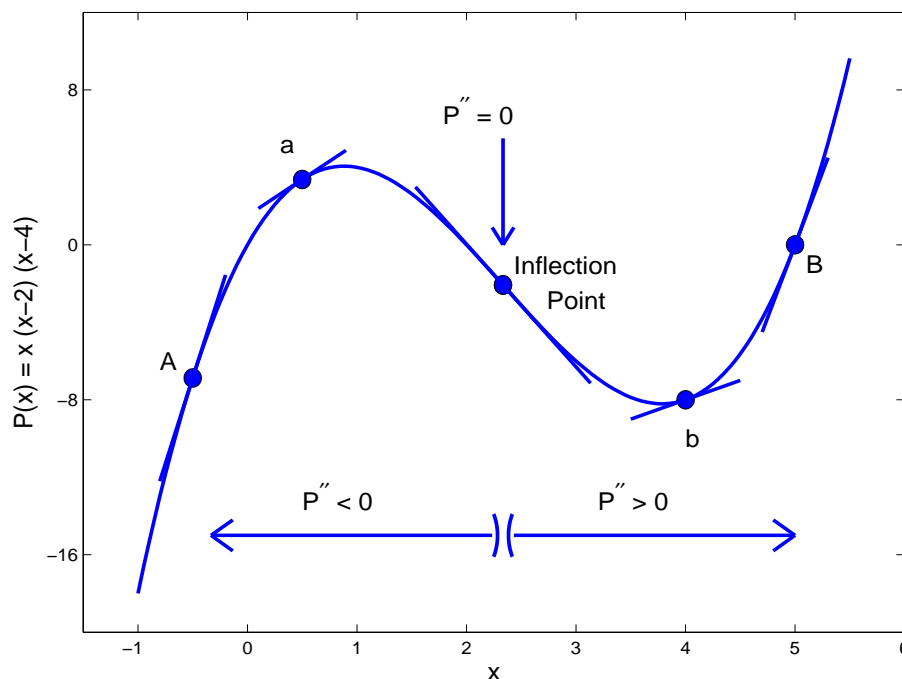

Figure 8.3: Graphs of $P(x) = x(x - 2)(x - 4)$. a. The slope is decreasing on $(-\infty, 7/3)$; the tangents lie above the graph except for the points of tangency and the graph is concave down. b. $(7/3, 19/3)$ is an inflection point; the tangent crosses the graph at that point. The slope is increasing on $(7/3, -\infty)$; the tangents lie below the graph except for the points of tangency and the graph is convex up.

8.1.2 The arithmetic mean is greater than or equal to the geometric mean.

We prove here Theorem 5.2.2 which was stated without proof in Subsection 5.2.1 in which the number e was shown to be $\lim_{h \rightarrow 0} (1 + h)^{1/h}$.

Theorem 5.2.2. If a_1, a_2, \dots, a_n is a sequence of n positive numbers then

$$\frac{a_1 + a_2 + \dots + a_n}{n} \geq \sqrt[n]{a_1 a_2 \dots a_n} \tag{8.1}$$

with equality only when $a_1 = a_2 = \dots = a_n$.

In the proof we use the facts that for any integer $n > 1$

$$1 + (n - 1) \left({}^n\sqrt{t} \right) = n \sqrt[n]{t} \quad \text{for } t = 1 \tag{8.2}$$

$$1 + (n - 1) \left({}^n\sqrt{t} \right) > n \sqrt[n]{t} \quad \text{for } t > 1 \tag{8.3}$$

Proof of Equations 8.2 and 8.3. Suppose $n > 1$ is an integer and

$$F(t) = 1 + (n - 1) \left({}^n\sqrt{t} \right) - n \sqrt[n]{t} = 1 + (n - 1) t^{\frac{1}{n-1}} - n t^{\frac{1}{n}}$$

Then $F(1) = 1 + (n - 1) \times 1 - n \times 1 = 0$ and Equation 8.2 is satisfied. Next $F'(t)$ is computed as

$$F'(t) = \left[1 + (n - 1) t^{\frac{1}{n-1}} - n t^{\frac{1}{n}} \right]'$$

$$\begin{aligned}
 &= 0 + (n-1) \frac{1}{n-1} t^{\frac{1}{n-1}-1} - n \frac{1}{n} t^{\frac{1}{n}-1} \\
 &= t^{-\frac{n-2}{n-1}} - t^{-\frac{n-1}{n}} \\
 &= t^{-\frac{n-2}{n-1}} \left(1 - t^{-\frac{1}{n(n-1)}} \right)
 \end{aligned}$$

For $t > 1$ both factors are greater than zero and $F'(t) > 0$ for $t > 1$. It follows from Theorem 8.1.2 that F is increasing for $t > 1$. Because $F(1) = 0$ and F is increasing for $t > 1$, for $t > 1$

$$F(t) > 0$$

$$1 + (n-1) \sqrt[n-1]{t} - n \sqrt[n]{t} > 0$$

$$1 + (n-1) \sqrt[n-1]{t} > n \sqrt[n]{t}$$

Equation 8.3 is satisfied. ■ *End of proof of Equations 8.2 and 8.3.*

Proof of Theorem 5.2.2. We proceed by induction. First we prove that if a_1 and a_2 are two positive numbers then $(a_1 + a_2)/2 \geq \sqrt[3]{a_1 a_2}$.

$$(a_1 - a_2)^2 \geq 0$$

$$a_1^2 - 2a_1 a_2 + a_2^2 \geq 0$$

$$a_1^2 + 2a_1 a_2 + a_2^2 \geq 4a_1 a_2$$

$$\frac{(a_1 + a_2)^2}{4} \geq a_1 a_2$$

$$\frac{a_1 + a_2}{2} \geq \sqrt[3]{a_1 a_2}$$

Furthermore, $(a_1 - a_2)^2 = 0$ only when $a_1 = a_2$ and equality holds in each expression of the previous array only when $a_1 = a_2$. The statement in Theorem 5.2.2 is valid with $n = 2$.

Now suppose n is an integer, $n \geq 3$, and Equation 8.1 is valid for sequences of length $n - 1$ and a_1, a_2, \dots, a_n is a sequence of positive numbers of length n . We assume without loss of generality that a_n is the smallest number in a_1, a_2, \dots, a_n , and consider the sequence $b_k = a_k/a_n$, $k = 1, n$. Then $b_k \geq 1$ and $b_n = 1$. Consequently,

$$t = b_1 b_2 \cdots b_{n-1} b_n = b_1 b_2 \cdots b_{n-1} \geq 1$$

with equality only for $b_1 = b_2 = \cdots = b_{n-1} = 1$. Observe that $b_1 = b_2 = \cdots = b_{n-1} = 1$ only if $a_1 = a_2 = \cdots = a_n$.

From Equations 8.2 and 8.3 we know that $1 + (n-1) \sqrt[n-1]{t} \geq n \sqrt[n]{t}$ for $t \geq 1$ with equality only for $t = 1$. Therefore

$$1 + (n-1) \left(\sqrt[n-1]{b_1 b_2 \cdots b_{n-1}} \right) \geq n \sqrt[n]{b_1 b_2 \cdots b_n}$$

By the induction hypothesis

$$b_1 + b_2 + \cdots + b_{n-1} \geq (n-1) \left(\sqrt[n-1]{b_1 b_2 \cdots b_{n-1}} \right),$$

so that

$$\begin{aligned} 1 + b_1 + b_2 + \cdots + b_{n-1} &\geq 1 + (n-1) \left(\sqrt[n-1]{b_1 b_2 \cdots b_{n-1}} \right), \\ &\geq n \sqrt[n]{b_1 b_2 \cdots b_{n-1}}. \end{aligned}$$

Multiply all all terms by a_n and we get

$$a_n + a_1 + a_2 + \cdots + a_{n-1} \geq n \sqrt[n]{a_1 a_2 \cdots a_n}$$

or

$$\frac{a_1 + a_2 + \cdots + a_n}{n} \geq \sqrt[n]{a_1 a_2 \cdots a_n}$$

Equality holds in the previous five expressions only if $b_1 = b_2 = \cdots = b_{n-1} = 1$, in which case $a_1 = a_2 = \cdots = a_n$.

End of proof.

Exercises for Section 8.1, Some geometry of the derivative.

Exercise 8.1.1 Argue that e^x is an increasing function.

Exercise 8.1.2 Argue that $\sin x$ is an increasing function on $0 \leq x \leq \pi/2$.

Exercise 8.1.3 Suppose penicillin concentration is given by $C(t) = 8e^{-0.2t} - 8e^{-0.4t}$ $\mu\text{gm/ml}$ t hours after ingestion of a penicillin pill. For what time period is the concentration increasing? What is the maximum penicillin concentration?

Exercise 8.1.4 Suppose penicillin concentration is given by $C(t) = 0.4te^{-0.5t}$ $\mu\text{gm/ml}$ t hours after ingestion of a penicillin pill. For what time period is the concentration decreasing? What is the maximum penicillin concentration?

Exercise 8.1.5 Identify the intervals, if any, on which $f(x)$ is increasing and intervals, if any, on which f' is increasing.

- | | | | |
|-----------------------|------------------------|-------------------------------|------------------------|
| a. $f(x) = x^2 - 1$ | $-2 \leq x \leq 2$ | b. $f(x) = x^2 - x$ | $-2 \leq x \leq 2$ |
| c. $f(x) = x^3 - x^2$ | $-2 \leq x \leq 2$ | d. $f(x) = \frac{x}{x^2 + 1}$ | $-2 \leq x \leq 2$ |
| e. $f(x) = e^{-x}$ | $-2 \leq x \leq 2$ | f. $f(x) = xe^{-x}$ | $0 \leq x \leq 3$ |
| g. $f(x) = e^{-x^2}$ | $-2 \leq x \leq 2$ | h. $f(x) = e^{-2x} - e^{-x}$ | $0 \leq x \leq 4$ |
| i. $f(x) = \ln x$ | $0 < x \leq 2$ | j. $f(x) = x \ln x$ | $0 < x \leq 1$ |
| k. $f(x) = \cos x$ | $-\pi \leq x \leq \pi$ | l. $f(x) = \sin^2 x$ | $-\pi \leq x \leq \pi$ |

Exercise 8.1.6 We show in Chapter 9 that if n is an integer then

$$1 + 2 + \cdots + (n - 1) + n = \frac{n(n + 1)}{2}.$$

Use this and Theorem 5.2.2 to show that if n is an integer

$$\left(\frac{n + 1}{2}\right)^n \geq n!$$

where $n! = 1 \cdot 2 \cdot 3 \cdots (n - 1) \cdot n$.

Exercise 8.1.7 Trout, Moose, and Bear lakes are connected into a chain by a stream that runs into Trout Lake, out of Trout Lake into Moose Lake, out of Moose Lake and into Bear Lake and out of Bear Lake. The volumes of all of the three lakes are the same, and stream flow is constant into and out of all lakes. A load of waste is dumped into Trout Lake. With t measured in days and concentration measured in mg/l, the concentration of wastes in the three lakes is projected to be

$$\text{Trout Lake: } C_T(t) = 0.01e^{-0.05t}$$

$$\text{Moose Lake: } C_M(t) = 0.005te^{-0.05t}$$

$$\text{Bear Lake: } C_B(t) = 0.000025\frac{t^2}{2}e^{-0.05t}$$

For each lake, find the time interval, if any, on which the concentration in the lake is increasing.

8.2 Some Traditional Max-Min Problems.

We present a few of the large number of interesting optimization problems that are part of the culture of calculus. The basis for solving these problems is the following definition and theorem.

Definition 8.2.1 Suppose f is a function with domain, D , and c is a number in D .

1. The point $(c, f(c))$, is a *maximum* for f means that

$$\text{for all numbers } x \text{ in } D \quad f(x) \leq f(c)$$

2. The point $(c, f(c))$ is a *local maximum* for f means that there is an open interval (p, q) that contains c and

$$\text{for all numbers } x \text{ in } D \text{ and in } (p, q) \quad f(x) \leq f(c)$$

3. The point $(c, f(c))$ is an *interior local maximum* for f if D contains an open interval (p, q) that contains c and

$$\text{for all numbers } x \text{ in } (p, q) \quad f(x) \leq f(c)$$

4. Similar definitions are made for *minima*.

In Figure 8.4, the point B is a maximum for the graph and an interior maximum. The points A and C are local minima for the graph; A is an endpoint local minimum and C is an interior local minimum. The point D is an interior local maximum and E is an endpoint minimum.

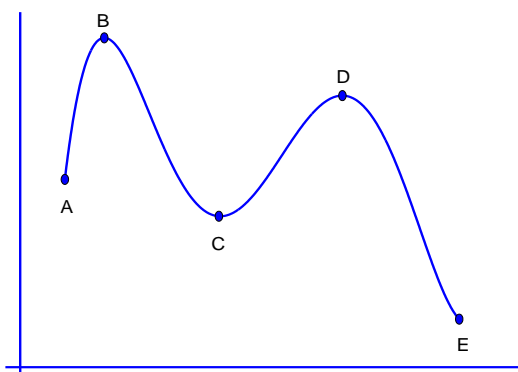

Figure 8.4: Maxima and minima. A is an endpoint local minimum, B is an interior maximum, C is an interior local minimum, D is an interior local maximum, E is an endpoint minimum.

If $(c, f(c))$ is a maximum for f then we may say that f attains its maximum value at c , or the maximum value of f occurs at c , or that the maximum value of f is $f(c)$. Thus, the sine function attains its maximum value at $\frac{\pi}{2}$ and the maximum value of the sine function is 1. Also the sine function attains its minimum value at $\frac{3\pi}{2}$ and the minimum value of the sine function is -1. The function $f(t) = t^3$ does not have a maximum value and does not have a minimum value. The word, 'value', is often omitted in these statements, and we may say, for example, that 1 is the maximum of the sine function and $f(t) = t^3$ has neither a maximum nor a minimum. Similar language is used with local and interior local maxima and minima.

Theorem 8.2.1 If $(c, f(c))$ is an interior local maximum for a function, f , and

$$\text{if } f'(c) \text{ exists, then } f'(c) = 0.$$

(Equivalently, if the graph of f has a tangent at an interior local maximum $(c, f(c))$, then that tangent is horizontal.)

Proof. Suppose $(c, f(c))$ is an interior local maximum for f , and (p, q) is an interval in D containing c for which $f(x) \leq f(c)$ for all x in (p, q) . We wish to show that $f'(c) = 0$. See Figure 8.5.

Suppose $p < b < c$. Then $b - c < 0$, and because c is a local maximum

$$f(b) \leq f(c) \quad \text{and} \quad f(b) - f(c) \leq 0 \quad \text{and} \quad \frac{f(b) - f(c)}{b - c} \geq 0$$

It follows that

$$f'^-(c) = \lim_{b \rightarrow c^-} \frac{f(b) - f(c)}{b - c} \geq 0.$$

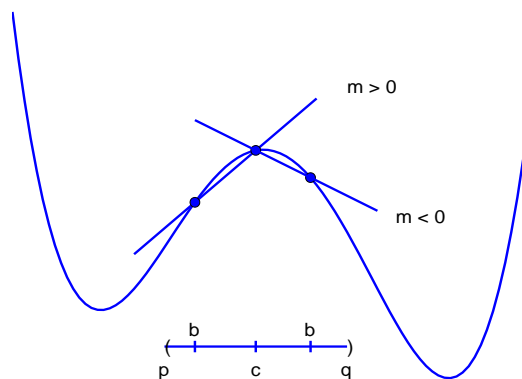

Figure 8.5: A local maximum and left and right secants.

Similar analysis shows that

$$f'^+(c) = \lim_{b \rightarrow c^+} \frac{f(b) - f(c)}{b - c} \leq 0.$$

If $f'(c)$ exists, $f'(c) = f'^-(c)$ and $f'(c) = f'^+(c)$. Therefore, $f'(c) = 0$. *End of Proof.*

Summary: Critical Points.

If c is a local maximum or local minimum for a function, f , defined on an interval $[a, b]$ then

1. $f'(c) = 0$, or
2. $f'(c)$ does not exist, or
3. c is either a or b .

The points c satisfying either 1, 2, or 3 are called the **Critical Points** for f on $[a, b]$.

In the examples considered in this book, there are usually only a few (no more than five, say) critical points. Then finding the maximum and minimum values only involves selecting from among at most five values of f .

Example 8.2.1 Suppose you are going to make a rectangular box with open top from a 3 meter by 4 meter sheet of tin. One procedure for doing so would be to cut squares of side x from each corner as shown in Figure 8.6A, and to fold the 'tabs' up. Four pieces of area x^2 would be discarded. What value of x will maximize the volume of the box you construct in this way? What will be the volume of the box of largest volume?

After the corners are cut, the 'core' of the tin that will make the bottom of the box will be of length $4 - 2x$ and width $3 - 2x$. The height of the box will be x and the volume of the box formed will be

$$V = (4 - 2x)(3 - 2x)x \quad 0 \leq x \leq \frac{3}{2}$$

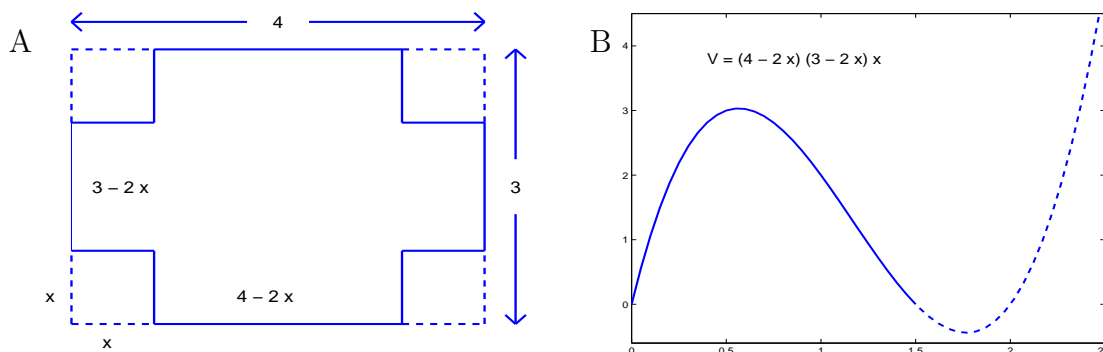

Figure 8.6: A. Diagram and B. graph (solid line) for Example 8.2.1

$0 \leq x \leq \frac{3}{2}$ insures that no side of the box is a negative number. A graph of V appears in Figure 8.6B. The dashed line shows an extension of the graph of $y = (4 - 2x)(3 - 2x)x$ that is not part of the graph of V . Compute V' :

$$\begin{aligned} V' &= [(4 - 2x)(3 - 2x)x]' \\ &= [(4 - 2x)]'(3 - 2x)x + (4 - 2x)[(3 - 2x)x]' \\ &= [(4 - 2x)]'(3 - 2x)x + (4 - 2x)[(3 - 2x)]'x + (4 - 2x)(3 - 2x)[x]' \end{aligned}$$

$$V' = 8x^2 - 28x + 12$$

Find the critical points:

- $V' = 0$

$$V' = 0 \quad \text{implies} \quad 8x^2 - 28x + 12 = 0 \quad \text{implies} \quad x = 3 \quad \text{or} \quad x = \frac{1}{2}$$

$x = \frac{1}{2}$ is in the domain of V but $x = 3$ is not.

- **V' does not exist.** No such points. V is a cubic function and has derivatives at every point.

- **End points.** The end points are $x = 0$ and $x = \frac{3}{2}$

The three critical values of x are 0 , $\frac{1}{2}$ and $\frac{3}{2}$

Find the maximum V :

$$V(0) = (4 - 2 \times 0)(3 - 2 \times 0) \times 0 = 0$$

$$V\left(\frac{1}{2}\right) = \left(4 - 2 \cdot \frac{1}{2}\right)\left(3 - 2 \cdot \frac{1}{2}\right) \cdot \frac{1}{2} = 3$$

$$V\left(\frac{3}{2}\right) = \left(4 - 2 \cdot \frac{3}{2}\right)\left(3 - 2 \cdot \frac{3}{2}\right) \cdot \frac{3}{2} = 0$$

The maximum volume is 3 and occurs with $x = \frac{1}{2}$. ■

In the preceding Example, we were given a surface area and asked to find the dimensions that will maximize the volume. A dual problem is to be given a required volume, find the dimensions that will minimize the required surface area.

Example 8.2.2 Suppose a box with a square base and closed top and bottom is to have a volume of 8 cubic meters. What dimensions of the box will minimize the surface area of the box?

Solution. Let x be the length of one side of the square base and y be the height of the box. Then the volume and surface area of the box are

$$V = x^2y \quad S = 2x^2 + 4xy$$

Because V is specified to be 8 cubic meters

$$8 = x^2y \quad \text{so that} \quad y = \frac{8}{x^2}$$

We substitute $\frac{8}{x^2}$ for y in the expression for S and get

$$S = 2x^2 + 4x\frac{8}{x^2} = 2x^2 + \frac{32}{x}$$

Figure for Example 8.2.2.2 A. Box with square bottom and volume = 8 m^3 . B. Graph of the function, $S(x) = 2x^2 + \frac{32}{x}$.

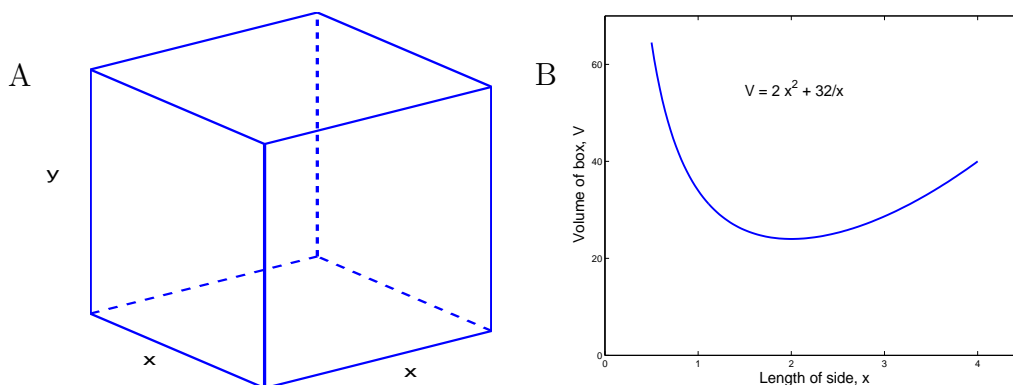

The domain of S is $x > 0$ (there are no endpoints, $x = 0$ is not allowed by the x in the denominator and there is no upper limit on x).

Then

$$\begin{aligned} S'(x) &= \left[2x^2 + \frac{32}{x} \right]' \\ &= [2x^2]' + [32x^{-1}]' \\ &= 4x - 32x^{-2} \end{aligned}$$

$S'(x)$ exists for all $x > 0$ and $S'(x) = 0$ yields

$$4x - 32x^{-2} = 0, \quad 4x^3 - 32 = 0, \quad x = 2 \quad \blacksquare$$

Thus we conclude that the base of the box should be 2 by 2 and because $x^2y = 8$ the height y of the box should also be 2. Examination of the graph of $S(x) = 2x^2 + \frac{32}{x}$ in Example Figure 8.2.2.2B suggests it is a minimum (and not, for example, a maximum!).

8.2.1 The Second Derivative Test.

There is a clever way of distinguishing local maxima from local minima using the second derivative. The following theorem is proved in Section 12.2.

Theorem 12.2.3. Suppose f is a function with continuous first and second derivatives throughout an interval $[a, b]$ and c is a number between a and b for which $f'(c) = 0$. Under these conditions:

1. If $f''(c) > 0$ then c is a local minimum for f (see Figure 8.7A).
2. If $f''(c) < 0$ then c is a local maximum for f (see Figure 8.7B).

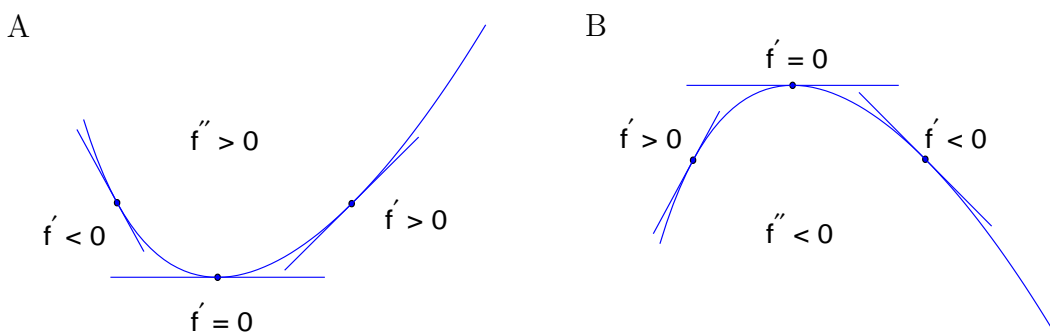

Figure 8.7: A. An interior local minimum, $f''(c) > 0$. B. An interior local maximum, $f''(c) < 0$.

In Example 8.2.2, $S'(x) = 4(x - 8x^{-2})$, so that

$$S''(x) = [4(x - 8x^{-2})]' = 4(1 + 16x^{-3})$$

Now $S'(2) = 0$, and $S''(2) = 12 > 0$, so by the second derivative test, $x = 2$ is a local minimum for S , as we previously concluded.

Example 8.2.3 The salmon and tuna cans shown in Example Figure 8.2.3.3 both contain fish. Why are they shaped so differently?

Suppose the criterion for making cans is to minimize the amount of metal required to hold a fixed amount of fish (the cans show Net Wt. 14.5 oz and 16 oz; we did not find cans holding equal weights of fish). Which can most closely meets the criterion?

Figure for Example 8.2.3.3 A. Salmon and tuna cans.



Question: Of all cans of volume equal to 1, which has the smallest surface area?

Assume that the 'can' (cylinder) in Example Figure 8.2.3.3 has volume equal to 1. The area of the top end of the can is πr^2 and the circumference of the top lid is $2\pi r$. The volume, V , of the can is

$$V = \pi r^2 h$$

and the surface area, S , of the can is

$$S = 2\pi r^2 + 2\pi r h$$

Figure for Example 8.2.3.3 A. A can of volume 1. B. A graph of $S(r) = 2\pi r^2 + \frac{2}{r}$

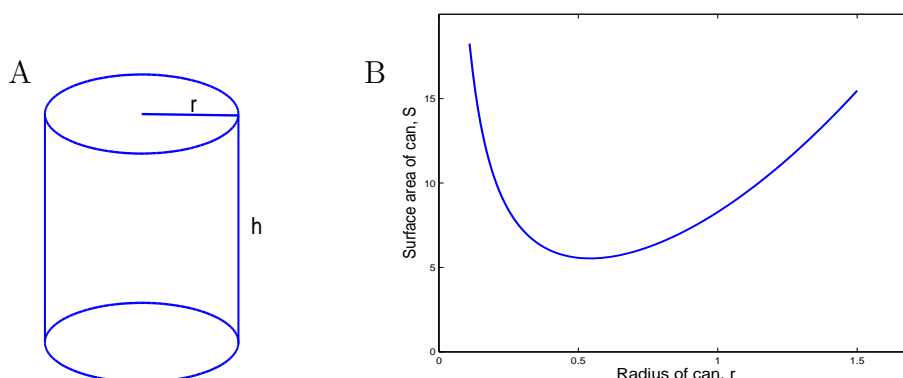

The requirement that the volume be 1 yields

$$1 = \pi r^2 h \quad \text{and solving for } h \text{ yields} \quad h = \frac{1}{\pi r^2}$$

We substitute this value into the expression for S and obtain

$$S = 2\pi r^2 + 2\pi r \frac{1}{\pi r^2} \quad S = 2\pi r^2 + \frac{2}{r}$$

The domain for S is $r > 0$ (there are no endpoints).

From the graph of S in Figure 8.2.3.3B it appears that there is a single minimum at about $r = 0.5$. We find the critical points.

$$S'(r) = \left[2\pi r^2 + \frac{2}{r} \right]' = [2\pi r^2]' + [2r^{-1}]' = 4\pi r - 2r^{-2}$$

The requirement $S'(r) = 0$ yields

$$4\pi r - 2r^{-2} = 0, \quad 4\pi r^3 - 2 = 0, \quad r = \frac{1}{\sqrt[3]{2\pi}} \doteq 0.542$$

Recall that $h = \frac{1}{\pi r^2}$ so that the ratio of h to r (height to radius ratio) that gives minimum surface area is

$$\frac{h}{r} = \frac{1/\pi r^2}{r} \Big|_{r=1/\sqrt[3]{2\pi}} = \frac{1}{\pi r^3} \Big|_{r=1/\sqrt[3]{2\pi}} = 2$$

Thus the height should be twice the radius, or equal to the diameter. ■

8.2.2 How to solve these problems.

There are some procedures we have been using that will help you solve these problems. They are listed in rough order of use and applied to an example.

- **Read the problem!**

Problem: Find the rectangle of largest area that can be inscribed in a semicircle of radius 1.

- **Draw a picture.** (Representative of the problem!)

Picture should have a semicircle of radius 1 and a rectangle inscribed in it. Also draw a radius to a corner of the rectangle. Figure 8.8A.

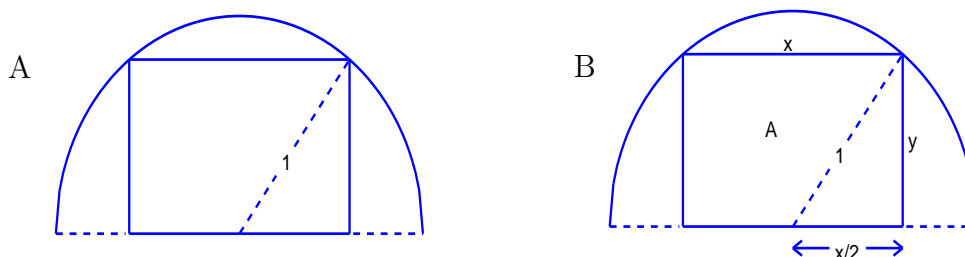

Figure 8.8: A. A semicircle of radius 1 with inscribed rectangle. B. Labels for the diagram in A.

- **Label parts of the picture.** This will introduce symbols for important parameters of the problem.

x and y should label horizontal and vertical sides of the rectangle, and A is the area of the rectangle. Figure 8.8B.

- **Write relations between the parameters.**

$$\left(\frac{x}{2}\right)^2 + y^2 = 1 \text{ and } A = xy.$$

- **Write a function of a single variable.** Write the parameter to be optimized in terms of a single adjustable parameter (variable).

Solve for y in $\left(\frac{x}{2}\right)^2 + y^2 = 1$ and substitute into $A = xy$.

$$A = x\sqrt{1 - x^2/4}$$

- **Draw a graph.** It is usually easy to draw a graph of your function on a calculator and the graph will often reveal the maximum and minimum points. You may end the process at this step with a calculator based estimate of the answer. A graph of $A = x\sqrt{1 - x^2/4}$ appears in Figure 8.9 and the maximum appears to be about $x = 1.5$.

- **Look for a clever simplification.**

The value of x that minimizes A also minimizes A^2 and $A^2 = x^2 - x^4/4$. You have your choice: Compute the derivative of $A = x\sqrt{1 - x^2/4}$ or compute the derivative of $A^2 = x^2 - x^4/4$. (Choose A^2 !!)

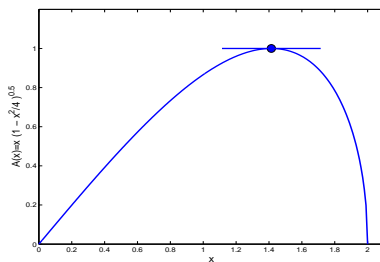

Figure 8.9: The graph of $A = x\sqrt{1 - x^2/4}$.

- **Find the critical points.** Compute the first derivative; find where it is zero or fails to exist; examine the end points.

$$[A^2]' = 2x - x^3 \quad \text{exists for all } x$$

$$[A^2]' = 0 \quad \implies \quad x = 0 \quad \text{or} \quad x = \sqrt{2}$$

The critical points are $x = \sqrt{2}$ and the end points $x = 0$ and $x = 2$.

$A^2(0) = 0$, $A^2(\sqrt{2}) = 1$, $A^2(2) = 0$. At this stage we know that $x = \sqrt{2}$ maximizes $A^2(x)$ because the maximum has to occur at one of the critical points. For illustrations, we also:

- Use the second derivative test, if needed and applicable.

$$[A^2]'' = 2 - 3x^2 \quad [A^2]'' \Big|_{x=\sqrt{2}} = -4$$

$[A^2]'' \Big|_{x=\sqrt{2}}$ is negative, so $x = \sqrt{2}$ is a local maximum. To see that it is actually a maximum, we have to check the other critical points.

Explore 8.2.1 Selection of labels on a figure can simplify or complicate the equations you derive. The previous figure is shown with the horizontal side of the rectangle being $2x$ instead of x . Write the equations that correspond to $(\frac{x}{2})^2 + y^2 = 1$, $A = xy$ and $A = x\sqrt{1 - x^2/4}$ from the previous analysis.

Figure for Exercise 8.2.0 Improved labels for Figure 8.8A.

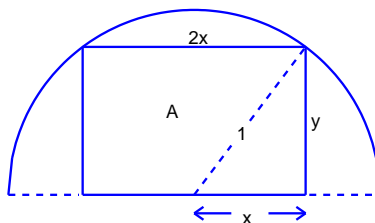

Example 8.2.4 Snell’s Law When you see a fish in a lake it typically is below where it appears to be. A spear, arrow, bullet, rock or other projectile launched toward the image of the fish that you see will pass above the fish. The different speeds of light in air and in water cause the light beam traveling from the fish to your eye to bend at the surface of the lake. The apparent location of the fish is marked as a dotted fish in Figure 8.2.4.4.

Figure for Example 8.2.4.4 A. Light ray from fish to observer. The dotted fish is the apparent location of the fish.

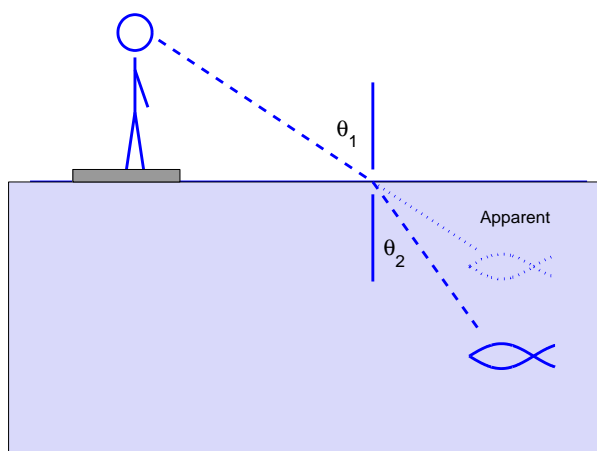

Pierre Fermat asserted in 1662 that the path of the light beam will be that path that minimizes the total time of travel in the two media. The speed of light in water, v_2 , is about 0.75 times the speed of light in air, v_1 . Suppose d is the horizontal distance between your eye and the fish, h_1 is the height of your eye above the water and h_2 is the depth of the fish below the surface of the lake. Finally let x be the horizontal distance between your eye and the point at which the beam passes through the surface of the lake.

Figure for Example 8.2.4.4 B. Light ray from fish to observer with labels.

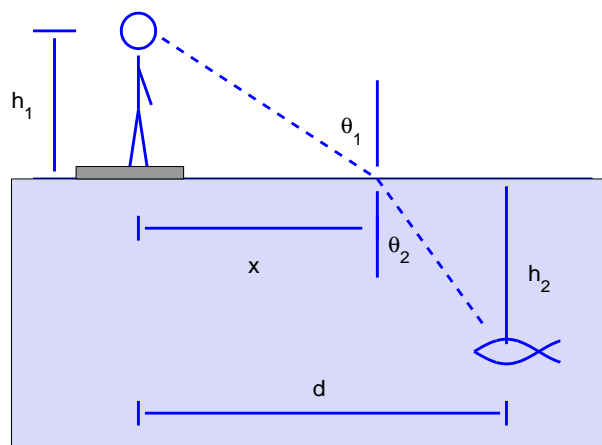

The distances the light ray travels in air and water are

$$\text{Air distance: } \sqrt{h_1^2 + x^2} \qquad \text{Water distance: } \sqrt{h_2^2 + (d - x)^2}$$

The times that the light spends traversing air and traversing water are (distance/velocity)

$$\text{Air time: } \frac{\sqrt{h_1^2 + x^2}}{v_1} \qquad \text{Water time: } \frac{\sqrt{h_2^2 + (d - x)^2}}{v_2}$$

The total time, T , for the ray to travel from the fish to your eye is

$$T = \frac{\sqrt{h_1^2 + x^2}}{v_1} + \frac{\sqrt{h_2^2 + (d - x)^2}}{v_2} \qquad 0 \leq x \leq d$$

Our task is to find the value of x that minimizes T . A graph of T is shown for values $v_1 = 1$, $v_2 = 0.75$, $d = 10$ meters, $h_1 = 2$ meters, $h_2 = 3$ meters. As tempting as it may be, it is not the time to get clever and square each term in the previous equation, for it is not generally true that $(a + b)^2 = a^2 + b^2$. Instead we compute T' directly and find that

$$T' = \frac{\frac{x}{\sqrt{h_1^2 + x^2}}}{v_1} - \frac{\frac{d - x}{\sqrt{h_2^2 + (d - x)^2}}}{v_2}$$

Figure for Example 8.2.4.4 Transit time for a light ray from fish to observer for parameter values $v_1 = 1$, $v_2 = 0.75$, $d = 10$ meters, $h_1 = 2$ meters, $h_2 = 3$ meters. The distance, x , for which the transit time is minimum is a bit less than 7 meters. v_a is the velocity of light in air.

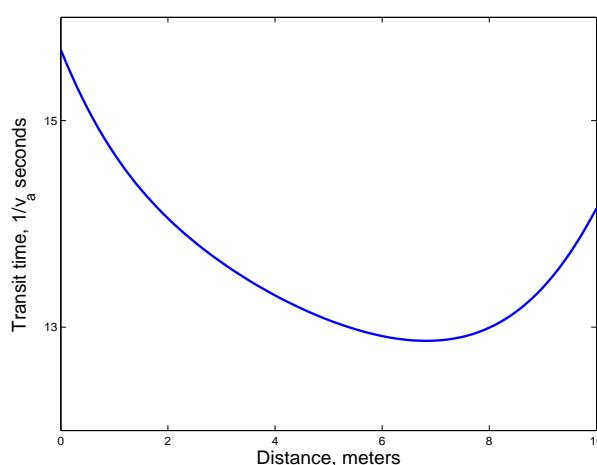

Setting $T' = 0$ and solving for x is not advised. We take a qualitative approach instead, and return to the geometry and identify two angles, θ_1 and θ_2 , the angles the light ray makes with a vertical line through the point of intersection with the surface. They are marked in both figures 8.2.4.4 and 8.2.4.4. It may be seen that

$$\frac{x}{\sqrt{h_1^2 + x^2}} = \sin \theta_1 \quad \text{and} \quad \frac{d - x}{\sqrt{h_2^2 + (d - x)^2}} = \sin \theta_2$$

and

$$T' = \frac{\sin \theta_1}{v_1} - \frac{\sin \theta_2}{v_2}$$

Observe from the geometry that as x moves from 0 to d , θ_1 increases from 0 to a positive number and θ_2 decreases from a positive number to 0. There is a single value of x where the graphs of

$$\frac{\sin \theta_1}{v_1} \quad \text{and} \quad \frac{\sin \theta_2}{v_2}$$

cross and at that point $T' = 0$ and

$$\frac{\sin \theta_1}{v_1} = \frac{\sin \theta_2}{v_2} \tag{8.4}$$

Equation 8.4 is referred to as Snell's law and applies to many problems of optics.

Because for water and air, $v_2 = 0.75 v_1$, and we would have

$$\frac{\sin \theta_1}{v_1} = \frac{\sin \theta_2}{0.75v_1} \quad \text{or} \quad \frac{\sin \theta_1}{1} = \frac{\sin \theta_2}{0.75} = \frac{4}{3} \sin \theta_2$$

we would have

$$\sin \theta_1 > \sin \theta_2 \quad \text{or} \quad \theta_1 > \theta_2$$

which implies that the light ray bends down into the water as shown, and the fish is actually below its apparent position.

Exercises for Section 8.2, Some Traditional Max-Min Problems.

Exercise 8.2.1 Suppose you have a 3 meter by 4 meter sheet of tin and you wish to make a box that has tin on the bottom and on two opposite sides. The other two sides are of wood that is in plentiful supply. You are going to make a rectangular box by folding up panels of width x across the ends that are 3 meters wide as shown in Figure 8.2.1. What value of x will maximize the volume of the box and what is the volume?

Figure for Exercise 8.2.1 Diagram for Exercise 8.2.1.

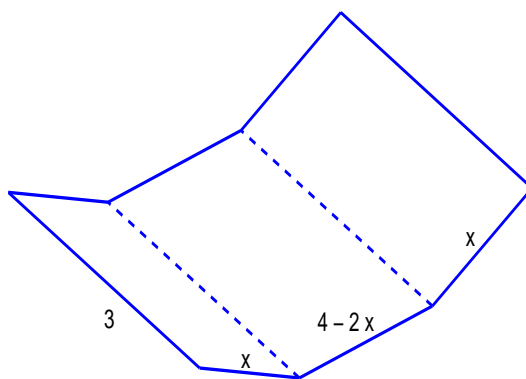

Exercise 8.2.2 In Exercise 8.2.1, would it be better (make a box of larger volume) to fold up panels of width x across the sides that are 4 meters long?

Exercise 8.2.3 Dissatisfied with having to discard the four corners as in Example 8.2.1, you decide to take another approach. From the 3 by 4 meter panel, you will cut two strips of width x across an end that is 3 meters wide, fold up two similar strips of width x and use the first two strips to make the other sides. See Figure 8.2.3. The two strips you cut may be too long, so that you may still have to discard some tin. What value of x will make a box of the largest volume and what is the volume?

Figure for Exercise 8.2.3 Diagram for Exercise 8.2.3.

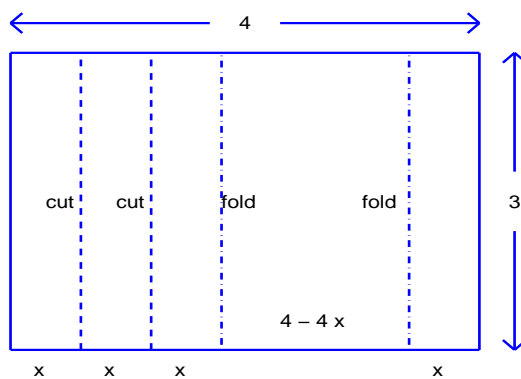

Exercise 8.2.4 A box with a square base and open top has surface area of 12 square meters (Figure 8.2.4). What dimensions of the box will maximize the volume?

Figure for Exercise 8.2.4 Box with square base and surface area = 12 m² for Exercise 8.2.4.

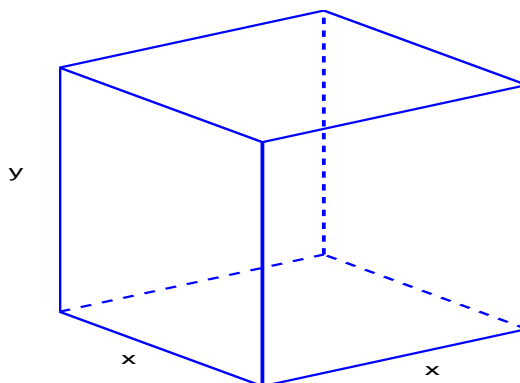

Exercise 8.2.5 Electron micrographs of diatoms are shown in Exercise Figure 8.2.5. Diatoms are phytoplankton that originated some 200 million years ago and are found in marine, fresh water and moist terrestrial environments, and contribute some 45 percent of the oceans organic production. The shells of the diatoms illustrated are like pill boxes (a cylindrical cup caps another cylindrical cup and a 'girdle' surrounds the overlap of the shells) and some parts are permeable and other parts appear to be impermeable. (Other diatoms have quite different structures, oblong and pennate, for example.) Typically the structure of such shells optimize some aspect of the organism, subject to functional constraints. Make measurements of the diatoms and discuss the optimality of the use of materials to make the shell, with the constraint that light must penetrate the shell.

Figure for Exercise 8.2.5 Electron micrographs of diatoms for Exercise 8.2.5. A. *Cyclotella comta* is the dominant component of the spring diatom bloom in Lake Superior.

<http://www.glerl.noaa.gov/seagrant/GLWL/Algae/Diatoms/Diatoms.html> B. *Thalassiosira pseudonana*, the first eukaryotic marine phytoplankton for which the whole genome was sequenced.

Micrograph by Nils Kroger, Universitat Regensburg, from http://www.jgi.doe.gov/News/news_9_30_04.html or from

<http://gtresearchnews.gatech.edu/newsrelease/diatom-structure.htm>

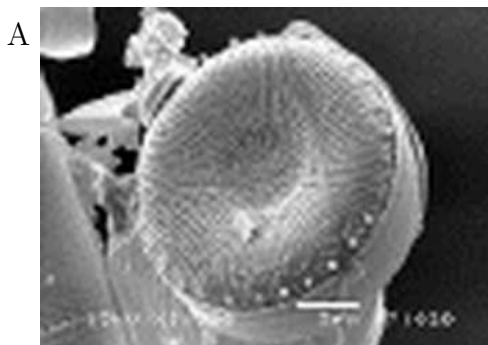

B. See the Department of Energy or Georgia Tech web page.

Exercise 8.2.6 From Example 8.2.4. Show that

$$\left[\frac{\sqrt{h_1^2 + x^2}}{v_1} + \frac{\sqrt{h_2^2 + (d-x)^2}}{v_2} \right]' = \frac{x}{\sqrt{h_1^2 + x^2}} - \frac{d-x}{\sqrt{h_2^2 + (d-x)^2}}$$

Exercise 8.2.7 Find the area of the largest rectangle that can be inscribed in a right triangle with sides of length 3 and 4 and hypotenuse of length 5.

Exercise 8.2.8 Two rectangular pens of equal area are to be made with 120 meters of fence. An exterior fence surrounding a rectangle is first constructed and then an interior fence that partitions the rectangle into two equal areas is constructed. What dimensions of the pens will maximize the total area of the two pens?

Exercise 8.2.9 A dog kennel with four pens each of area 7 square meters is to be constructed. An exterior fence surrounding a rectangular area is to be built of fence costing \$20 per meter. That rectangular area is then to be partitioned by three fences that are all parallel to a single side of the original rectangle and using fence that costs \$10 per meter. What dimensions of pens will minimize the cost of fence used?

Exercise 8.2.10 A ladder is to be put against a wall that has a 2 meter tall fence that is 1 meter away from the wall. What is the shortest ladder that will reach from the ground to the wall and go above the fence?

Exercise 8.2.11 a. What is the length of the longest ladder than can be carried horizontally along a 2 meter wide hallway and turned a corner into a 1 meter hallway? Suppose the floor to ceiling height in both hallways is 3 meters. b. What is the longest pipe that can be carried around the corner?

Exercise 8.2.12 A box with a square base and with a top and bottom and a shelf entirely across the interior is to be made. The total surface area of all material is to be 9 m^2 . What dimensions of the box will maximize the volume?

Exercise 8.2.13 A rectangular box with square base and with top and bottom and a shelf entirely across the interior is to have 12 m^3 volume. What dimensions of the box will minimize the material used?

Exercise 8.2.14 A box with no top is to be made from a 22 cm by 28 cm piece of card board by cutting squares of equal size from each corner and folding up the ‘tabs’. What size of squares should be cut from each corner to make the box of largest volume?

Exercise 8.2.15 A shelter is to be made with a 3 meter by 4 meter canvas sheet. There are equally spaced grommets at one meter intervals along the 4-meter edges of the canvas. Ropes are tied to the four grommets that are one meter from a corner and stretched, so that there is a two-meter by three-meter horizontal sheet with two one-meter by three-meter flaps on two sides. The other two sides are open. The two flaps are to be staked at the corners so that the flaps slope away from the region below the horizontal portion of the canvas. How high should the horizontal section be in order to maximize the volume of the shelter?

Exercise 8.2.16 An orange juice can has volume of $48\pi \text{ cm}^3$ and has metal ends and cardboard sides. The metal costs 3 times as much as the card board. What dimensions of the can will minimize the cost of material?

Exercise 8.2.17 The ‘strength’ of a rectangular wood beam with one side vertical is proportional to its width and the square of its depth. A sawyer is to cut a single beam from a 1 meter diameter log. What dimensions should he cut the beam in order to maximize the strength of the beam?

Exercise 8.2.18 A rectangular wood beam with one side vertical has a ‘stiffness’ that is proportional to its width and the cube of its depth. A sawyer is to cut a single beam from a 1 meter diameter log. What dimensions should he cut the beam in order to maximize the stiffness of the beam?

Exercise 8.2.19 A life guard at a sea shore sees a swimmer in distress 70 meters down the beach and 30 meters from shore. She can run 4 meters/sec and swim 1 meter per second. What path should she follow in order to reach the swimmer in minimum time?

Exercise 8.2.20 You stand on a bluff above a quiet lake and observe the reflection of a mountain top in the lake. Light from the mountain top strikes the lake and is reflected back to your eye, the path followed, by Fermat’s hypothesis, being that path that takes the least time. Show that the angle of incidence is equal to the angle of reflection. That is, show that the angle the beam from the mountain top to the point of reflection on the lake makes with the horizontal surface of the lake (the angle of incidence) is equal to the angle the beam from the point of reflection to your eye makes with the horizontal surface of the lake (the angle of reflection). Let v_a denote the velocity of light in air.

Exercise 8.2.21 Two light bulbs of different intensities are a distance, d , apart. At any point, the light intensity from one of the bulbs is proportional to the intensity of the bulb and inversely proportional to the square of the distance from the bulb. Find the point between the two bulbs at which the sum of the intensities of light from the two bulbs is minimum.

Exercise 8.2.22 An equation for continuous logistics population growth is

$$P' = RP \left(1 - \frac{P}{M}\right)$$

where P is population size, R is the low density growth rate, and M is the carrying capacity of the environment. For what value of P will the growth rate, P' be the greatest?

Exercise 8.2.23 Ricker’s model for population growth is

$$P' = RP e^{-\frac{P}{\alpha}}$$

where P is population size, R is the low density growth rate, and α reflects the carrying capacity of the environment. For what value of P will the growth rate, P' be greatest?

Exercise 8.2.24 A comet follows the parabolic path, $y = x^2$ and Earth is at (3,8). How close does the comet come to Earth?

Exercise 8.2.25 A tepee is to be covered with 30 buffalo skins. What should be the angle at the base of the tepee that will maximize the volume inside the tepee?

Note: The volume of a right circular cone with base radius r and height h is $\pi r^2 h/3$ and its lateral surface area is $\pi r \sqrt{r^2 + h^2}$.

Exercise 8.2.26 A very challenging exercise. A tepee is to be covered with 30 buffalo skins. The skins are a little longer than the height of the Indians that will be inside and not quite as wide as the height of the Indians. Thus the areas of the skins are approximately the square of the height of the Indians. The Indians wish to maximize the area inside the teepee in which they can walk standing upright. What angle at the base of the teepee will maximize that area?

8.3 Life Sciences Optima

Natural selection constantly optimizes life forms for reproductive success. Consequently, optima are endemic in living organisms and groups of organisms, but they are typically difficult to describe and analyze and vary with the organism. Biology optima are never as simple as the geometry problems of the previous sections, such as, "What is the size of the largest cube that can fit in a sphere?" An otherwise square cell confined to live in a sphere is very likely to become a sphere. Typically the optimum is a balance between opposing requirements as in the simplified model¹ of cell size included here. A few such problems are supplied for your analysis.

Example 8.3.1 Mathematical Model 8.3.1 Consider a bacterium that grows as a sphere, such as *streptococcus*. Its reproductive success is proportional to the energy that it produces.

1. Energy production is proportional to cell volume which provides space for processing and storage of nutrients.
2. Energy production is proportional to the concentration of nutrients inside the cell, which in turn is proportional to the ratio of the surface area of the cell to the volume of the cell.

If we concentrate only on component 1, we might write

$$\text{Energy Production}_1 = AV$$

where A is a positive constant. $\text{Energy Production}_1$ will be large if V is large and *streptococcus* cell size should increase without bound.

If we concentrate only on component 2, we might write

$$\text{Energy Production}_2 = B_0 \frac{S}{V} = B \frac{1}{\sqrt[3]{V}}$$

where B is a positive constant (for *streptococcus* cells which grow in the shape of a sphere, $S = \sqrt[3]{36\pi} V^{2/3}$). $\text{Energy Production}_2$ will be large if V is small and *streptococcus* cell size should decrease – to zero with no nutrient processing organs!

Large cells have large capacity for energy production, but are inefficient because of low nutrient concentration. Small cells have high nutrient concentration, but may have limited capacity to use the nutrients.

Caution: Smoke and mirrors ahead. How do we combine the two expressions of Energy Production? We choose the *harmonic mean* of the two. The harmonic mean of n numbers $\{a_1, a_2, \dots, a_n\}$ is defined by

$$\text{Harmonic mean} = \frac{n}{\frac{1}{a_1} + \frac{1}{a_2} + \dots + \frac{1}{a_n}} \quad (8.5)$$

Explore 8.3.1 The harmonic mean is useful for combining rates. Suppose you travel from city A to city B at rate r mph and travel from B back to A at a rate s mph. Show that the rate of the round trip is the harmonic mean of r and s .

¹A much more satisfactory model and analysis is presented in Kohei Yoshiyama and Christopher A. Klausmeier, Optimal cell size for resource uptake in fluids: A new facet of resource competition. *American Naturalist* 171 (2008), pp. 59-79

Now let's write the harmonic mean of the two Energy Productions as

$$\text{Energy Production} = \frac{2}{\frac{1}{AV} + \frac{1}{B/V^{1/3}}} = \frac{2AVB/V^{1/3}}{AV + B/V^{1/3}}$$

For illustration purposes, suppose $A = B = 1$ and examine the function

$$H(V) = \frac{2V V^{-1/3}}{V + V^{-1/3}}.$$

Shown in Figure 8.3.1.1 are the graphs of $y = 2V$, $y = 2V^{-1/3}$ and H . When $V \ll 1$, $V^{-1/3} \gg V$ and the denominator is $\approx V^{-1/3}$ and cancels the factor $V^{-1/3}$ in the numerator. Consequently, when $V \ll 1$, $H(V) \approx 2V$ and close to zero. Similarly, when $V \gg 1$, $H(V) \approx V^{-1/3}$ and is close to zero. There is an intermediate value of V for which H is maximum. You are asked to find that value in Exercise 8.3.1.

We have shown that the competing requirements of large capacity and high nutrient concentrations can be balanced to achieve an intermediate optimum cell size. We are ignorant of the values of A and B and have selected the harmonic mean only as a reasonably unbiased means of combining the two functions.

Figure for Example 8.3.1.1 Graphs of $y = 2V$, $y = 2V^{-1/3}$ and $H(V) = 2V V^{-1/3}/(V + V^{-1/3})$.

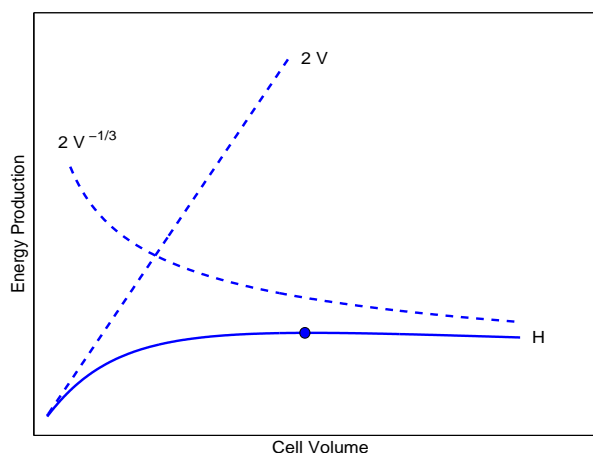

Exercises for Section 8.3, Life Sciences Optima

Exercise 8.3.1 Find the maximum value of $H(V) = 2V V^{-1/3}/(V + V^{-1/3})$ for $V > 0$.

Exercise 8.3.2 The *island body size rule* states that when an ecosystem becomes isolated on an island, say by rising sea levels, the species of large body size tend to evolve to a smaller body size, and species of small body size tend to increase in size. Craig McClain et al² found a similar contrast in the sea between shallow water where nutrient levels are high and deep water (depth greater than 200 meters) where nutrient levels are low. Gastropod genera that have large

²Craig R. McClain, Alison G. Boyer and Gary Rosenberg, The island rule and the evolution of body size in the deep sea, *Journal of Biogeography* 33 (2008), pp 1578-1584.

shallow-water species tend to have smaller deep-water representatives; those that have small shallow water species tend to have larger deep-water species.

Suppose the ratio of nutrient conversion to body size *vs* body size is similar to the graph in Figure 8.3.2 and that at high nutrient concentrations, nutrient conversion is not the limiting factor — predation and mate finding, for example, may be more important. Suppose further that at low nutrient concentrations, nutrient conversion becomes more important and nutrient conversion/body size must be greater than that for high nutrient levels. How is the graph consistent with the observed differences in body size?

Figure for Exercise 8.3.2 Hypothetical graph of the ratio of nutrient production to gastropod body size *vs* body size.

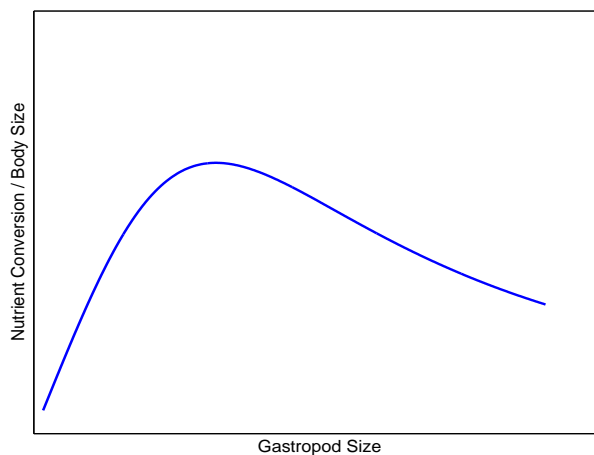

Exercise 8.3.3 Some small song birds intermittently flap their wings and glide with wings folded between flapping sessions. Why? R. M. Alexander³ suggests the following analysis.

The power required to propel an airplane at a speed u is

$$P = Au^3 + BL^2/u$$

where A and B are constants specific to the airplane and L is the upward force that lifts the plane. Au^3 represents the drag on the airplane due largely to the air striking the front of the craft.

- For what speed is the required power the smallest?
- The energy required to propel the airplane is $E = P/u$. For what speed is the energy required to propel the plane the smallest?
- How does the speed of minimum energy compare with the speed of minimum power?
- Suppose a bird has drag coefficient A_b with wings folded and $A_b + A_w$ with wings extended and flapping, and let x be the fraction of time the bird spends flapping its wings. Suppose that the speed of the bird while flapping its wings is the same as the speed when the wings are folded and that all of the lift is provided when the wings are flapping. The lift over one complete cycle should be

$$(1 - x) L_{\text{folded}} + x L_{\text{flapping}} = x L_{\text{flapping}} = m g$$

³R. McNeill Alexander, "Optima for Animals" Princeton University Press, Princeton, NJ, 1996, Section 3.1, pp 45-48.

where m is the mass of the bird. Then the power required while flapping is

$$P_{\text{flapping}} = (A_b + A_w)u^3 + B \left(\frac{mg}{x}\right)^2 \frac{1}{u}$$

Write an expression for P_{folded} .

e. The average power over a whole cycle should be

$$\bar{P} = (1 - x)P_{\text{folded}} + xP_{\text{flapping}} = A_b u^3 + xA_w u^3 + B \frac{m^2 g^2}{xu}$$

Find the value of x for which the average power over the whole cycle is minimum.

f. The average energy over a whole cycle is $\bar{E} = \bar{P}/u$. For what value of x is the average energy a minimum?

This problem is continued in Exercise 13.2.12

Alexander further notes that it may be necessary to consider also the efficiency of muscle contraction at different flapping rates.

Exercise 8.3.4 Read the amazing story of the kakapo at

http://evolution.berkeley.edu/evolibrary/news/060401_kakapo and the Wikipedia entry on kakapo. You might assume that in really good times, only males would be born and in really bad times only females would be born. Why is it that both males and females are retained in the natural population?

The next three exercises could form the basis of a semester project.

Exercise 8.3.5 Sickle cell anemia is an inherited blood disease in which the body makes sickle-shaped red blood cells. It is caused by a single mutation from glutamic acid to valine at position 6 in the protein Hemoglobin B. The gene for hemoglobin B is on human chromosome 11; a single nucleotide change in the codon for the glutamic acid, GAG, to GTG causes the change from glutamic acid to valine. The location of a genetic variation is called a *locus* and the different genetic values (GAG and GTG) at the location are called *alleles*.

People who have GAG on one copy of chromosome 11 and GTG on the other copy are said to be heterozygous and do not have sickle cell anemia and have elevated resistance to malaria over those who have GAG on both copies of chromosome 11. Those who have GTG on both copies of chromosome 11 are said to be homozygous and have sickle cell anemia – the hydrophobic valine allows aggregation of hemoglobin molecules within the blood cell causing a sickle-like deformation that does not move easily through blood vessels.

Let A denote presence of GAG and a denote presence of GTG on chromosome 11, and let AA , Aa and aa denote the various presences of those codons on the two chromosomes of a person (note: $Aa = aA$); AA , Aa and aa label are the genotypes of the person with respect to this locus. It is necessary to assume *non-overlapping generations*, meaning that all members of the population are simultaneously born, grow to sexual maturity, mate, leave offspring and die. Let P , Q and R denote the frequencies of AA , Aa and aa genotypes in a breeding population and let p and q denote the frequencies of the alleles A and a among the chromosomes in the same population. The frequencies P , Q , and R are referred to as *genotype frequencies* and p and q are referred to as *allele frequencies*. In a population of size, N , there will be $2N$ chromosomes and $P \times 2N + Q \times N$ of the chromosomes will be A .

In a mating of AA with Aa adults, the chromosome in the fertilized egg (zygote) obtained from AA must be A and the chromosome obtained from Aa will be A with probability $1/2$ and will be a with probability $1/2$. Therefore, the zygote will be AA with probability $1/2$ and will be Aa with probability $1/2$.

- a. Show that the allele frequencies p and q in a breeding population with genotype frequencies P , Q and R are given by

$$p = P + \frac{1}{2}Q \quad \text{and} \quad q = \frac{1}{2}Q + R.$$

- b. Assume a closed population (no migration) with random mating and no selection. Complete the table showing probabilities of zygote type in the offspring for the various mating possibilities, the frequencies of the mating possibilities, and the zygote genotype frequencies. Include zeros with the zygote type probabilities but omit the zeros in the zygote genotype frequencies. Random mating assumes that the selection of mating partners is independent of the genotypes of the partners.

Adult		Zygote types			Random mating frequency	Offspring Zygote type probabilities		
Male	Female	AA	Aa	aa		AA	Aa	aa
AA	AA	1	0	0	P^2	P^2		
AA	Aa	$1/2$	$1/2$	0	PQ	$\frac{1}{2}PQ$	$\frac{1}{2}PQ$	
AA	aa	0	1	0	PR		PR	
Aa	AA							
Aa	Aa				QQ	$\frac{1}{4}QQ$	$\frac{1}{2}QQ$	$\frac{1}{4}QQ$
Aa	aa				QR		$\frac{1}{2}QR$	$\frac{1}{2}QR$
aa	AA				PR		PR	
aa	aA							
aa	aa							
	Sum				1	Σ_{AA}	Σ_{Aa}	Σ_{aa}

- c. When the table is complete, you should see that

$$\begin{aligned} \Sigma_{Aa} &= \frac{1}{2}PQ + PR + \frac{1}{2}QP + \frac{1}{2}Q^2 + \frac{1}{2}QR + RP + \frac{1}{2}QR \\ &= PQ + 2PR + \frac{1}{2}Q^2 + QR = 2P\left(\frac{1}{2}Q + R\right) + Q\left(\frac{1}{2}Q + R\right) \\ &= (2P + Q)\left(\frac{1}{2}Q + R\right) = 2\left(P + \frac{1}{2}Q\right)\left(\frac{1}{2}Q + R\right) \\ &= 2pq \end{aligned}$$

Show that

$$\Sigma_{AA} = p^2 \quad \text{and} \quad \Sigma_{aa} = q^2$$

This means that under the random mating hypothesis, the *zygote genotype* frequencies of the offspring population are determined by the *allele* frequencies of the adults. This is referred to as the Hardy-Weinberg theorem. If the probability of an egg growing to adult and

contributing to the next generation of eggs is the same for all eggs, independent of genotype, then the allele frequencies, p and q , are constant after the first generation.

Random mating does not imply the promiscuity that might be imagined. It means that the selection of mating partner is independent of the genotype of the partner. In the United States, blood type would be a random mating locus; seldom does a United States young person inquire about the blood type of an attractive partner. In Japan, however, this seems to be a big deal, to the point that dating services arranging matches also match blood type. The major histocompatibility complex (MHC) of a young person would seem to be fairly neutral; few people even know their MHC type. It has been demonstrated, however, that young women are repulsed by the smell of men of the same MHC type as their own⁴.

- d. Show that in a closed random mating population with no selection, if the frequency of A in the adults in one generation is \hat{p} , then the frequency of A in adults in the next generation will also be \hat{p} .
- e. Suppose that because of malaria, an AA type egg, either male or female, has probability 0.8 of reaching maturity and mating and because of sickle cell anemia an aa type has only 0.2 probability of mating, but that an Aa type has 1.0 probability of mating. This condition is called *selection*. Then the distribution of genotypes in the egg and the mating populations will be

Genotype	AA	Aa	aa	
Egg	p^2	$2pq$	q^2	
Adult	$0.8p^2/F$	$2pq/F$	$0.2q^2/F$	where $F = 0.8p^2 + 2pq + 0.2q^2$

Find the frequency of A in the adult population. Note: This will also be the frequency of A in the next egg population.

- f. We call $F(p)$ the *balance* of the population, and because $p + q = 1$

$$F = F(p) = 0.8p^2 + 2p(1 - p) + 0.2(1 - p)^2$$

You will be asked in Exercise 8.3.8 to show that when the probability of reproduction depends on the genotype (*selection* is present), during succeeding generations, allele frequency, p , moves toward the value of local maximum of F .

1. Show that $F(p) = 1 - 0.2p^2 - 0.8(1 - p)^2$.
2. Find the value \hat{p} of p that maximizes $F(p)$.

Exercise 8.3.6 Consider two alleles A and a at a locus of a random mating population and the fractions of AA , Aa and aa zygotes that reach maturity and mate are in the ratio $1 + s_1 : 1 : 1 + s_2$ where s_1 and s_2 can be positive, negative, or zero, but $s_1 \geq -1$ and $s_2 \geq -1$. The balance function is

$$\begin{aligned} F(p) &= (1 + s_1)p^2 + 2pq + (1 + s_2)q^2 = (1 + s_1)p^2 + 2p(1 - p) + (1 + s_2)(1 - p)^2 \\ &= 1 + s_1 p^2 + s_2 (1 - p)^2 \end{aligned}$$

where p and q are the frequencies of A and a among the zygotes.

⁴Claus Wedekind, et al, MHC-Dependent mate preferences in humans, *Proceedings: Biological Sciences*, 260 (1995) 245-249.

- a. Sketch the graphs of F and find the values \hat{p} of p in $[0,1]$ for which $F(p)$ is a maximum for
1. $s_1 = 0.2$ and $s_2 = -0.3$.
 2. $s_1 = 0$ and $s_2 = -0.2$.
 3. $s_1 = -0.2$ and $s_2 = -0.3$.
 4. $s_1 = 0.2$ and $s_2 = 0.3$.
- b. Suppose that $s_1 + s_2 \neq 0$ and $0 \leq s_2/(s_1 + s_2) \leq 1$. Is it true that $\hat{p}s_2/(s_1 + s_2)$ is the value of p in $[0,1]$ for which $F(p)$ is a maximum?

Exercise 8.3.7 Use the notation of the previous exercise, Exercise 8.3.6.

- a. Run the following MATLAB program.

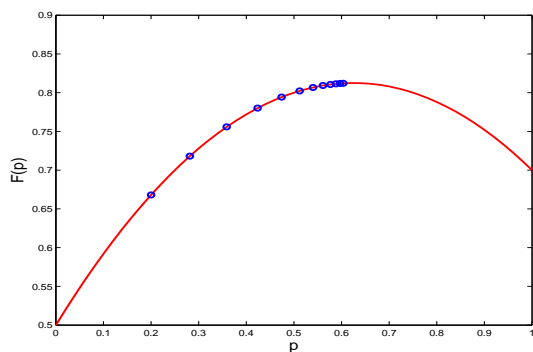

```
close all;clc;clear
p=0.2;q=1-p;s1=-0.3;s2=-0.5;
for k = 1:12
    pp(k) = p;
    AA = p^2; Aa = 2*p*q; aa = q^2;
    F(k) = (1+s1)*AA + Aa + (1+s2)*aa;
    AA_n = (1+s1)*AA/F(k);
    Aa_n = Aa/F(k);
    aa_n = (1+s2)*aa/F(k);
    p = AA_n+0.5*Aa_n;
    q = 0.5*Aa_n+aa_n;
end
[pp.' F. ']
x = [0:0.02:1];
y = 1+s1*x.^2 +s2*(1-x).^2;
plot(x,y,'r','linewidth',2)
xlabel('p','fontsize',16);
ylabel('F(p)','fontsize',16)
hold('on')
plot(pp,F,'o','linewidth',2)
```

- b. The program computes the allele frequency, p , of allele A through 12 generations of selection and produces the graph shown to the left of the program. Mark the initial and second, third and fourth values of p . What is the limiting value of p ?
- c. Change the second line of the program to `p=0.9; q=1-p; s1=-0.3; s2=-0.5;` , and run the new program.
- d. Change the second line of the program to `p=0.2; q=1-p; s1=0.3; s2=0.5;` , and run the new program.
- e. Use some other values of p , s_1 , and s_2 , and run the program.

Exercise 8.3.8 The program shown in Exercise 8.3.7 assumes a population with an A-allele frequency of $p=0.2$ and computes future populations assuming that there is selection pattern AA: 0.7; Aa: 1.0; aa: 0.5. The heterozygote, Aa, is favored over either of the two homozygotes, AA and aa; the condition is referred to as *over dominance* and occurs in sickle cell anemia. The A-allele frequency of $p=0.2$ is out of balance with the selection forces acting on the population, and in subsequent generations p moves toward the value \hat{p} that maximizes the balance function,

$$\begin{aligned} F(p) &= (1 + s_1)p^2 + 2pq + (1 + s_2)q^2 = (1 + s_1)p^2 + 2p(1 - p) + (1 + s_2)(1 - p)^2 \\ &= 1 + s_1p^2 + s_2(1 - p)^2. \end{aligned}$$

This exercise proves that it always happens in the case of over dominance.

- a. Consider two alleles A and a at a locus of a random mating population with non-overlapping generations and the fractions of AA , Aa and aa zygotes that reach maturity and mate are in the ratio $1 + s_1 : 1 : 1 + s_2$ where $-1 \leq s_1 < 0$ and $-1 \leq s_2 < 0$. Show that the maximum value of

$$F(p) = 1 + s_1p^2 + s_2(1 - p)^2 \quad \text{occurs at} \quad \hat{p} = \frac{s_2}{s_1 + s_2} \quad \text{and} \quad F(\hat{p}) = 1 + \frac{s_1s_2}{s_1 + s_2} < 1.$$

- b. Assume the egg allele frequencies in the first generation are A p_0 and a $q_0 = 1 - p_0$ and that the egg genotype frequencies are AA p_0^2 , Aa $2p_0q_0$ and aa q_0^2 . After selection the adult genotype frequencies are

$$\begin{array}{ccc} AA & Aa & aa \\ \frac{(1 + s_1)p_0^2}{F(p_0)} & \frac{2p_0q_0}{F(p_0)} & \frac{(1 + s_2)q_0^2}{F(p_0)} \end{array} \quad \text{where} \quad F(p_0) = 1 + s_1p_0^2 + s_2(1 - p_0)^2$$

Show that the frequency, p_1 of A in the adult population (and therefore of the resulting egg population) is

$$p_1 = \frac{(1 + s_1)p_0^2 + p_0(1 - p_0)}{F(p_0)}$$

- c. For the n^{th} generation

$$p_{n+1} = \frac{(1 + s_1)p_n^2 + p_n(1 - p_n)}{F(p_n)} \quad \text{where} \quad F(p_n) = 1 + s_1p_n^2 + s_2(1 - p_n)^2 \quad (8.6)$$

It is the sequence $\{p_0, p_1, p_2, \dots\}$ that we wish to show converges to \hat{p} .

We will consider only the case $0 < p_0 < \hat{p}$.

In Grungy Algebra I, shown below, we find that

$$p_{n+1} - p_n = -\frac{p_n(1 - p_n)(s_1 + s_2)}{F(p_n)}(\hat{p} - p_n) \quad (8.7)$$

- d. Show that

$$-\frac{p_n(1 - p_n)(s_1 + s_2)}{F(p_n)} > 0$$

- e. Show that if $\hat{p} - p_n$ is positive then $p_{n+1} - p_n$ is positive, so that $p_{n+1} > p_n$.

f. Show that

$$\begin{aligned} \frac{p_n(1-p_n)}{F(p_n)} &= \frac{p_n(1-p_n)}{1+s_1p_n^2+s_2(1-p_n)^2} \\ &\leq \frac{p_n(1-p_n)}{1-p_n^2-(1-p_n)^2} \\ &= \frac{1}{2} \\ \frac{p_n(1-p_n)}{F(p_n)} &\leq \frac{1}{2}. \end{aligned} \tag{8.8}$$

g. Show that

$$-\frac{p_n(1-p_n)(s_1+s_2)}{F(p_n)} \leq 1$$

h. Conclude that

$$p_{n+1} - p_n \leq (\hat{p} - p_n), \quad \text{so that } p_{n+1} \leq \hat{p}$$

i. We now know that $\{p_0, p_1, p_2, \dots\}$ is an increasing sequence bounded above by \hat{p} . Does $\{p_0, p_1, p_2, \dots\}$ converge to \hat{p} ?

j. Show that in the extreme case where $s_1 = s_2 = -1$,

$$\hat{p} = \frac{1}{2}, \quad \text{and for any } p_0, \quad p_1 = \frac{1}{2}, \quad \text{and } p_2 = \frac{1}{2}, \quad p_3 = \frac{1}{2} \dots$$

k. Now assume $s_1 > -1$ or $s_2 > -1$. In Not So Grungy Algebra II (shown below) we show that

$$\hat{p} - p_{n+1} = \left[(s_1 + s_2) \frac{p_n(1-p_n)}{F(p_n)} + 1 \right] (\hat{p} - p_n) \tag{8.9}$$

and in Mystical Algebra III we show that

$$0 \leq (s_1 + s_2) \frac{p_n(1-p_n)}{F(p_n)} + 1 < 1. \tag{8.10}$$

Use Equations 8.9 and 8.10 to show that $\{p_0, p_1, p_2, \dots\}$ converges to \hat{p} .

l. **Grungy Algebra I.** Proof of Equation 8.7. There are at least four mistakes in the following equations that you should correct. Begin with Equation 8.6,

$$\begin{aligned} p_{n+1} &= \frac{(1+s_1)p_n^2 + p_n(1-p_n)}{F(p_n)} \\ p_{n+1} - p_n &= \frac{(1+s_1)p_n^2 + p_n(1-p_n)}{F(p_n)} - p_n \\ &= p_n \left[\frac{(1+s_1)p_n + (1-p_n)}{1+s_1p_n^2+s_2(1-p_n)^2} - 1 \right] \\ &= p_n \frac{(1+s_1)p_n + (1-p_n) - 1 + s_1p_n^2 + s_2(1-p_n)^2}{F(p_n)} \end{aligned}$$

$$\begin{aligned}
&= p_n \frac{p_n + s_1 p_n + 1 - p_n - 1 - s_1 p_n^2 - s_2(1 - p_n)^2}{F(p_n)} \\
&= p_n \frac{s_1 p_n - s_1 p_n^2 - s_2(1 - p_n)^2}{F(p_n)} \\
&= p_n(1 - p_n) \frac{s_1 p_n - s_2(1 - p_n)}{F(p_n)} \\
&= p_n(1 - p_n)(s_1 + s_2) \frac{\frac{s_2}{s_1 + s_2} - p_n}{F(p_n)} \\
p_{n+1} - p_n &= -p_n(1 - p_n)(s_1 + s_2) \frac{\hat{p} - p_n}{F(p_n)}
\end{aligned}$$

m. **Not So Grungy Algebra II.** Proof of Equation 8.9. Check the last step. Begin with Equation 8.7:

$$\begin{aligned}
p_{n+1} - p_n &= -\frac{p_n(1 - p_n)(s_1 + s_2)}{F(p_n)}(\hat{p} - p_n) \\
p_n - p_{n+1} &= \frac{p_n(1 - p_n)(s_1 + s_2)}{F(p_n)}(\hat{p} - p_n) \\
p_n - \hat{p} + \hat{p} - p_{n+1} &= \frac{p_n(1 - p_n)(s_1 + s_2)}{F(p_n)}(\hat{p} - p_n) \\
\hat{p} - p_{n+1} &= \left[\frac{p_n(1 - p_n)(s_1 + s_2)}{F(p_n)} \right] (\hat{p} - p_n)
\end{aligned}$$

n. **Mystical Algebra III.** Proof of Inequalities 8.10. Remember that $0 > s_1 \geq -1$ and $0 > s_2 \geq -1$ and either $s_1 > -1$ or $s_2 > -1$. Then

$$\begin{aligned}
0 &> s_1 + s_2 > -2 \\
0 &> (s_1 + s_2) \frac{p_n(1 - p_n)}{F(p_n)} > -2 \frac{p_n(1 - p_n)}{F(p_n)} \stackrel{??}{\geq} -1 \\
1 &> (s_1 + s_2) \frac{p_n(1 - p_n)}{F(p_n)} + 1 \geq 0
\end{aligned}$$

8.4 Related Rates

Typical Problem and Solution:

Air is pumped into a spherical balloon at the rate of 6 liters per minute. At what rate is the radius of the balloon expanding when the volume of the balloon is 36 liters?

Two variables, volume V and radius r , **are intrinsically related** by the relation

$$V = \frac{4}{3}\pi r^3.$$

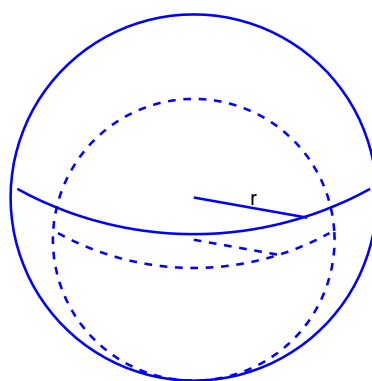

One variable (V) is changing with time. The other variable (r) must also change. Almost always the chain rule is used.

$$V'(t) = \frac{4}{3}\pi [(r(t))^3]' = \frac{4}{3}\pi 3(r(t))^2 r'(t) = 4\pi (r(t))^2 r'(t).$$

Evaluation of variables. For all time, $V' = 6$ liters/minute $= 6000$ cm³/min. **At the given instant**, $V = 36$ liters $= 36000$ cm³, and

$$\text{from } 36000 = \frac{4}{3}\pi r^3 \quad \text{we get} \quad r = \frac{30}{\sqrt[3]{\pi}} \text{ cm.}$$

Then we write

$$6000 = 4\pi \left(\frac{30}{\sqrt[3]{\pi}}\right)^2 r' \quad \text{and compute} \quad r' = \frac{10}{12\sqrt[3]{\pi}} \doteq 0.57 \frac{\text{cm}}{\text{min}}.$$

The solutions to all of the problems of this section follow the pattern of the solution just illustrated. In each of the problems, there are two or more variables intrinsically related (by one or more equations); the variables are changing with time; at a given instant, values of some of the variables and some of the rates of change are given and the problem is to evaluate the remaining variables and rates of change. Some more examples follow.

Example 8.4.1 A 10 meter ladder leans against a wall. The foot of the ladder slips horizontally at the rate of 1 meter per minute. At what rate does the top of the ladder descend when the top is 6 meters from the ground?

Draw a picture. See Figure 8.4.1.1. Let x be the distance from the wall to the foot of the ladder and let y be the distance from the ground to the top of the ladder. We are asked to find y'

at a certain instant. Because the top of the ladder is descending, we expect our answer (y') to be negative.

x and y are intrinsically related.

$$x^2 + y^2 = 10^2$$

Figure for Example 8.4.1.1 Ladder leaning against a wall and sliding down the wall.

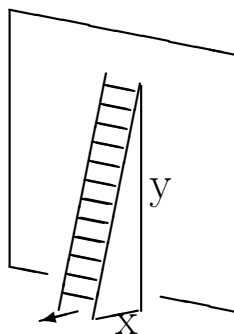

x and y are changing with time, and

$$(x(t))^2 + (y(t))^2 = 10^2$$

Differentiate with respect to t (use the chain rule, twice):

$$2x(t)x'(t) + 2y(t)y'(t) = 0$$

'When' The instant, t_0 , specified in the problem is defined by $y = 6$. At that instant $x^2 + 6^2 = 10^2$, so that $x = 8$. The problem also specifies $x'(t) = 1$ for all t . The actual value of t_0 is not required; we know that $x(t_0) = 8$, $y(t_0) = 6$, and $x'(t_0) = 1$. Therefore

$$(2 \times 8 \times 1) + (2 \times 6 \times y') = 0 \quad \text{and} \quad y' = -\frac{4}{3} \text{ meter/min}$$

Example 8.4.2 In an aqueous solution the concentrations of H^+ and OH^- ions satisfy

$$[\text{H}^+] [\text{OH}^-] = 10^{-14}$$

If in a certain lake the pH is 6 ($[\text{H}^+] = 10^{-6}$) and is decreasing at the rate of 0.1 pH units per year, at what rate is the hydroxyl concentration, $[\text{OH}^-]$, increasing?

Solution: It is useful to take the \log_{10} of the two sides of the previous equation:

$$\log_{10} ([\text{H}^+] [\text{OH}^-]) = \log_{10} 10^{-14}$$

$$\log_{10} [\text{H}^+] + \log_{10} [\text{OH}^-] = -14$$

$$\text{pH} + \log_{10} [\text{OH}^-] = -14$$

$$\text{pH} + \frac{\ln [\text{OH}^-]}{\ln 10} = -14$$

Now we take derivatives of each term:

$$[\text{pH}]' + \left[\frac{\ln [\text{OH}^-]}{\ln 10} \right]' = [-14]'$$

$$[\text{pH}]' + \frac{1}{\ln 10} \frac{1}{[\text{OH}^-]} [\text{OH}^-]' = 0$$

At the given instant, ($[\text{H}^+] = 10^{-6}$) so that

$$[10^{-6}] [\text{OH}^-] = 10^{-14} \quad \text{and} \quad [\text{OH}^-] = 10^{-8}$$

Also, by the hypothesis, $[\text{pH}]' = -0.1$. Therefore

$$[\text{pH}]' + \frac{1}{\ln 10} \frac{1}{[\text{OH}^-]} [\text{OH}^-]' = 0$$

$$= -0.1 + \frac{1}{\ln 10} \frac{1}{10^{-8}} [\text{OH}^-]' = 0$$

$$[\text{OH}^-]' = 0.1 (\ln 10) 10^{-8} \doteq 0.23 \cdot 10^{-8} \frac{\text{ions}}{\text{liter}} \text{per second}$$

Example 8.4.3 In Exercise 7.3.7 we discussed the following problem.

A piston is linked by a 20 cm tie rod to a crank shaft which has a 5 cm radius of motion (see Figure 8.4.3.3). Let $x(t)$ be the distance from the rotation center of the crank shaft to the end of the tie rod and $\theta(t)$ be the rotation angle of the crank shaft, measured from the line through the centers of the crank shaft and piston. The crank shaft is rotating at 100 revolutions per minute. The goal is to locate the point of the cylinder at which the piston speed is the greatest.

We present an analysis of this problem that illustrates some common steps in such problems.

Figure for Example 8.4.3.3 Crank shaft, tie rod, and piston (or fly rod, fly line, and fish).

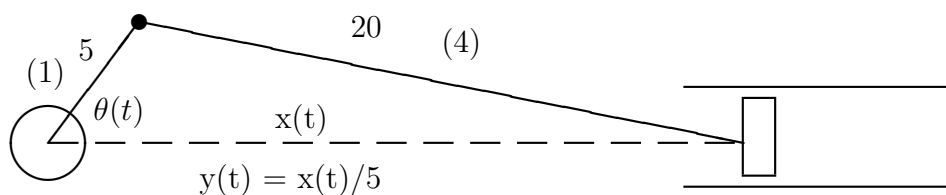

Step 1. We rescale the problem by dividing dimensions by 5. We are more accurate manipulating 1 and 5 than manipulating 4 and 20. Thus the parenthetical entries (1), (4), and $(y(t) = x(t)/5)$ in Figure 8.4.3.3. Observe that $3 \leq y \leq 5$.

By the Law of Cosines,

$$4^2 = 1^2 + y^2(t) - 2 \cdot 1 \times y(t) \cdot \cos \theta(t). \tag{8.11}$$

Differentiation of this equation yields

$$0 = 0 + 2y(t)y'(t) - 2y'(t) \cos \theta(t) - 2y(t)(-\sin \theta(t))\theta'(t)$$

$$\begin{aligned}\frac{y'(t)}{\theta'(t)} &= \frac{y(t) \sin \theta(t)}{\cos \theta(t) - y(t)} \\ \frac{y'(t)}{200\pi} &= \frac{y(t) \sin \theta(t)}{\cos \theta(t) - y(t)},\end{aligned}\tag{8.12}$$

(100 rotations per minute implies that $\theta' = 200\pi$). From Equation 8.11

$$\cos \theta = \frac{y^2 - 15}{2y} \quad 3 \leq y \leq 5,$$

and from $\sin^2 \theta + \cos^2 \theta = 1$ we find

$$\sin \theta = \pm \sqrt{1 - \left(\frac{y^2 - 15}{2y}\right)^2} = \pm \frac{\sqrt{4y^2 - (y^2 - 15)^2}}{2y} \quad 3 \leq y \leq 5.$$

Now use Equation 8.12 to write $y'(t)$ in terms of $y(t)$, and suppress the (t) .

$$\frac{y'}{200\pi} = \pm \frac{y \frac{\sqrt{4y^2 - (y^2 - 15)^2}}{2y}}{\frac{y^2 - 15}{2y} - y} = \mp \frac{y \sqrt{-y^4 + 34y^2 - 225}}{y^2 + 15}$$

Note the change from \pm to \mp . Now to find the value of y for which y' is maximum, we might wish to compute $[y']' = \frac{d(y')}{dy}$ and find where it is zero. Computation of $[y']'$ from the previous equation appears to be messy.

Step 2. Instead we note that where y' is a maximum, $[y']^2$ is also a maximum and we look at

$$z = \left[\frac{y'}{200\pi}\right]^2 = \left(\mp \frac{y \sqrt{-y^4 + 34y^2 - 225}}{y^2 + 15}\right)^2 = \frac{-y^6 + 34y^4 - 225y^2}{(y^2 + 15)^2}$$

This ratio of polynomials is easier to differentiate.

$$\begin{aligned}\frac{dz}{dy} &= \frac{(y^2 + 15)^2 [-y^6 + 34y^4 - 225y^2]' - (-y^6 + 34y^4 - 225y^2) [(y^2 + 15)^2]'}{(y^2 + 15)^4} \\ &= (-2y) \frac{y^6 + 45y^4 - 1245y^2 + 3375}{(y^2 + 15)^3}, \quad 3 \leq y \leq 5\end{aligned}$$

Explore 8.4.1 You should check the previous computation.

Step 3. We need to know the value of y for which $z' = 0$. That will only occur when $y = 0$ (outside of $3 \leq y \leq 5$) and when the numerator, $y^6 + 45y^4 - 1245y^2 + 3375 = 0$. It is helpful that the denominator is never zero. So solve

$$y^6 + 45y^4 - 1245y^2 + 3375 = 0$$

Clever Step 4. Only even powers of y occur in this sixth degree polynomial. Let $w = y^2$ and solve

$$w^3 + 45w^2 - 1245w + 3375 = 0$$

Just as the roots to a quadratic equation are given by the formula $\frac{-b \pm \sqrt{b^2 - 4ac}}{2a}$, there are formulas for the roots to cubics, but they are seldom useful. Instead we use a polynomial solver on a calculator and compute the roots

$$w_1 = -64.96412 \quad w_2 = 16.88784 \quad w_3 = 3.07628$$

The root $w_2 = 16.88784$ is relevant to our problem. We remember that $w = y^2$ and $x = 5y$ and compute

$$y = \sqrt{16.88784} = 4.10948 \quad x = 5y = 5 \times 4.10948 = 20.55$$

From the dimensions of the crank shaft and tie rod, x is between 15 and 25. The highest speed of the piston occurs at $x = 20.55$, to the right of midpoint of its motion.

Exercises for Section 8.4 Related Rates

Exercise 8.4.1 A pebble dropped into a pond makes a circular wave that travels outward at a rate 0.4 meters per second. At what rate is the area of the circle increasing 2 seconds after the pebble strikes the pond?

Exercise 8.4.2 A boat is pulled toward a dock by a rope through a pulley that is 5 meters above the water. The rope is being pulled at a constant rate of 15 meters per minute. At the instant when the boat is 12 meters from the dock, how fast is the boat approaching the dock?

Exercise 8.4.3 Corn is conveyed up a belt at the rate of 10 m^3 per minute and dropped onto a conical pile. The height of the pile is equal to twice its radius. At what rate is the top of the pile increasing when the volume of the pile is 1000 m^3 ? (Note: Volume of a cone is $\frac{1}{3}\pi r^2 h$ where r is the radius of the base and h is the height of the cone.)

Exercise 8.4.4 A light house beacon makes one revolution every two minutes and shines a beam on a straight shore that is one kilometer from the light house. How fast is the beam of light moving along the shore when it is pointing toward the point of the shore closest to the light house? How fast is the beam of light moving along the shore when it is pointing toward a point that is one kilometer from the closest point of the shore to the light house?

Exercise 8.4.5 Two planes are traveling at the same altitude toward an airport. One plane is flying at 500 kilometers per hour from a position due North of the airport and the other plane is traveling at 300 kilometers per hour from a position due East of the airport. At what rate is the distance between the planes decreasing when the first plane is 8 km North of the airport and the second plane is 5 km East of the airport?

Exercise 8.4.6 Two planes are traveling at the same altitude toward an airport. One plane is flying at 500 kilometers per hour from a position 8 km due North of the airport and the other plane is traveling at 300 kilometers per hour from a position 5 km due East of the airport. Assuming the planes continue on a path over and beyond the airport, how long afterward and at what distance will the planes be the closest to each other?

Exercise 8.4.7 A woman 1.7 meters tall walks under a street light that is 10 meters above the ground. She is walking in a straight line at a rate of 30 meters per minute. How fast is the tip of her shadow moving when she is 5 meters beyond the street light?

Exercise 8.4.8 A gas in a perfectly insulated container and at constant temperature satisfies the gas law $pv^{1.4} = \text{constant}$. When the pressure is 20 Newtons per cm^2 the volume is 3 liters. The gas is being compressed at the rate of 0.2 liters per minute. How fast is the pressure changing at the instant at which the volume is 2 liters?

Exercise 8.4.9 Find x' at the instant that $x = 2$ if $y' = 5$ and

$$\text{a. } xy + y = 9 \quad \text{b. } xe^y = 2e \quad \text{c. } x^2y + xy^2 = 2$$

Exercise 8.4.10 A point is moving along the parabola $y = x^2$ and its y coordinate increases at a constant rate of 2. At what rate is the distance from the point to $(4,0)$ changing at the instant at which $x = 2$?

Exercise 8.4.11 Accept as true that if a particle moves along a graph of $y = f(x)$ then the speed of the particle along the graph is $\sqrt{(x')^2 + (y')^2}$.

(The notation means that x' is the rate at which the x -coordinate is increasing, y' denotes the rate at which the y -coordinate is increasing and the speed of the particle is the rate at which the particle is moving along the curve.)

- Suppose a particle moves along the graph of $y = x^2$ so that $y' = 2$. What is x' when $y = 2$? How fast is the particle moving?
- Suppose a particle moves along the circle $x^2 + y^2 = 1$ so that its speed is 2π . Find x' when $x = 1$.
- Suppose a particle moves along the circle $x^2 + y^2 = 1$ so that its speed is 2π . Find x' when $x = 0$. (Two answers.)

8.5 Finding roots to $f(x) = 0$.

It is unfortunately frequent to encounter simple equations such as $xe^{-x} = a$ for which no amount of algebraic manipulation yields a solution such as $x = \text{an expression in } a$. Three numerical schemes are commonly used to solve specific instances of such equations: iteration, the bisection method, and Newton's method.

Example 8.5.1 Problem. Solve $xe^{-x} = a$ for $a = 0.2$ and $a = 2$.

Solution. Graphs help explore the problem. Shown in Figure 8.10A is a graph of $y = xe^{-x}$. It is apparent that the highest point of the graph has y -coordinate about $y = 0.37$. We are relieved of solving $xe^{-x} = 2$; there is no solution. The dashed line at $y = 0.2$ does intersect the graph of $y = xe^{-x}$; at two points so there are two solutions to $xe^{-x} = 0.2$, r_1 at about $x = 0.3$ and r_2 at about $x = 2.5$.

Iteration. There is a simple scheme that sometimes works. $xe^{-x} = 0.2$ is equivalent to $x = 0.2e^x$. We can guess $x_0 = 0.3$ as an estimate of r_1 , and compute a new estimate $x_1 = 0.2e^{x_0} = 0.2e^{0.3} = 0.2700$. Then compute $x_2 = 0.2e^{x_1} = 0.2e^{0.2700} = 0.2620$. Continue and we find that

$$x_3 = 0.2599, \quad x_4 = 0.2594, \quad x_5 = 0.2592, \quad x_6 = 0.2592.$$

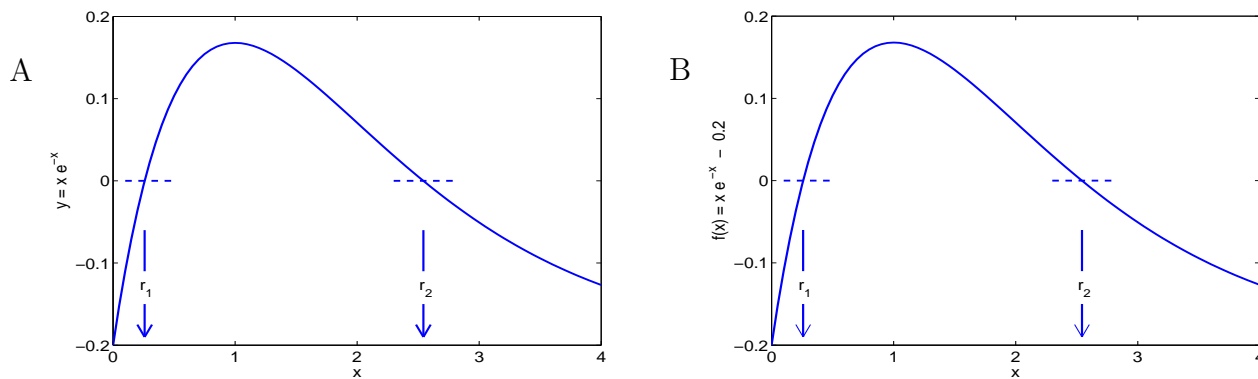

Figure 8.10: A. Graph of $y = xe^{-x}$. B. Graph of $y = xe^{-x} - 0.2$.

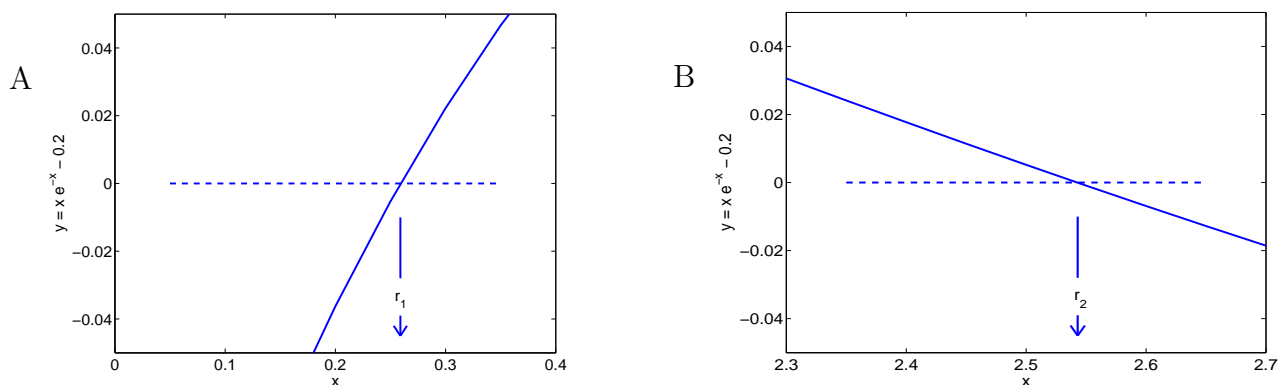

Figure 8.11: A. Graph of $y = xe^{-x} - 0.2$ on $0 \leq x \leq 0.4$. B. Graph of $y = xe^{-x} - 0.2$ on $2.35 \leq x \leq 2.37$.

Correct to four decimal places, $x = 0.2592$ is a solution to $xe^{-x} = 0.2$. This scheme fails for finding the root r_2 near $x = 2.5$ and an alternate scheme is suggested in Exercise 8.5.1.

The general pattern of this method is that you convert your problem of solving $g(x) = 0$ into a problem of solving $x = f(x)$. Then you make a guess of x_0 as an approximation to the root, r , for which both $g(r) = 0$ and $r = f(r)$. Then you compute $x_1 = f(x_0)$, $x_2 = f(x_1)$, $x_3 = f(x_2)$, \dots . The condition for this to succeed is that $|f'(r)| < 1$ and is reported in Theorem 14.4.1.

Iterations can be easily performed on a hand calculator that has an 'ANS' button, meaning, perform the previous step using the current answer on the screen. An example to solve $x = 0.2e^{-x}$ is

```
0.3 ENTER 0.2 * e^(-ANS) ENTER ENTER ENTER ENTER ENTER
Produces .30000 .14816 .17246 .16832 .16902 .16890
```

The '-' sign is denotes 'negative' and not 'subtraction.'

Another approach. It is common to modify the problem and examine the function,

$$f(x) = xe^{-x} - 0.2$$

the graph of which is shown in Figure 8.11B. We are searching for points where the graph of f crosses the x -axis (that is, $f(x) = 0$).

Bisection. A rather plodding, but sure way to find r_1 is called the *bisection method*. We observe from Figure 8.11A that r_1 appears to be between 0.2 and 0.3. We check

$$f(0.2) = .2 e^{-.2} - .2 = -0.03625 \quad \text{and} \quad f(0.3) = .3 e^{-.3} - .2 = 0.22245$$

Because $f(0.2)$ is negative and $f(0.3)$ is positive, we think f should be zero somewhere between 0.2 and 0.3.

Next we check the value of f at the midpoint of $[0.2, 0.3]$ and

$$f(0.25) = -0.0052998$$

Because $f(0.25)$ is negative and $f(0.3)$ is positive, we think f should be zero somewhere between 0.25 and 0.3.

Now we check the value of f at the midpoint of $[0.25, 0.3]$ and

$$f(0.275) = 0.0088823$$

Because $f(0.25)$ is negative and $f(0.275)$ is positive, we think f should be zero somewhere between 0.25 and 0.275.

Obviously this can be continued as long as one has patience, and the interval containing the root decreases in length by a factor of 0.5 each step. Computation of seven decimal places in $r_1 = 0.2591711$ requires

$$0.1 \times 0.5^n < 0.5 \times 10^{-8} \quad \text{which implies that} \quad n > 24.25$$

or 25 steps.

Newton's Method. It may not be a surprise to find that Isaac Newton, in the days of quill and parchment and look up table for trigonometric and exponential and logarithm functions⁵, developed a very efficient method for finding roots to equations. We suppose, as before, that a function, f , is defined on an interval, $[a, b]$, that for some number, r , in $[a, b]$ $f(r) = 0$, and we are to compute an approximate value of r . It is also necessary to know the derivative, f' of f (which Newton was also good at).

Newton began with an approximate value x_0 to r . Then he found the equation of the tangent to the graph of f at the point, $(x_0, f(x_0))$. He reasoned that the tangent was close to the graph of f and should cross the horizontal axis at a number, x_1 , close to r , where the graph of f crosses the axis. x_1 is easy to compute, and is an approximate value to r . Newton repeated the process as necessary, but we will see that not many repetitions are required.

An equation of the tangent to the graph of f at the point $(x_0, f(x_0))$ is

$$\frac{y - f(x_0)}{x - x_0} = f'(x_0) \quad \text{Equation of Tangent}$$

The tangent crosses the horizontal axis at $(x_1, 0)$. By substitution,

$$\frac{0 - f(x_0)}{x_1 - x_0} = f'(x_0)$$

We solve for x_1 and find

$$x_1 = x_0 - \frac{f(x_0)}{f'(x_0)}$$

⁵Trigonometry has a long history and was well summarized by Claudius Ptolemy (ca 90 - ca 168 AD) in his "Amalgamest"; John Napier published "Minfici Logarithmum Canonis Descriptio" (Description of the Wonderful Rule of Logarithms) in 1614.

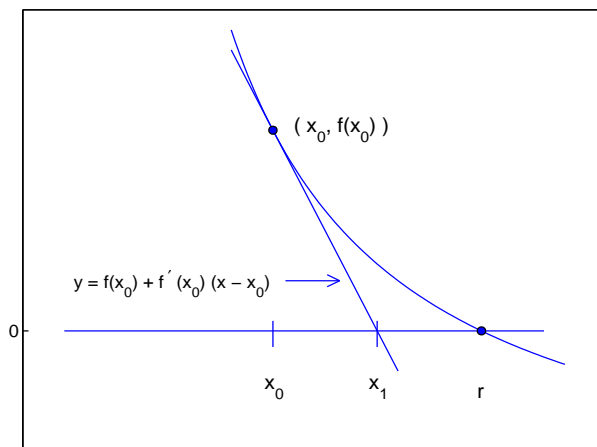

Figure 8.12: Diagram of Newton's root finding method.

If we repeat this process, we will find a next approximation, x_2 to r , where

$$x_2 = x_1 - \frac{f(x_1)}{f'(x_1)}$$

The general formula is

$$x_0 \text{ given} \quad x_{n+1} = x_n - \frac{f(x_n)}{f'(x_n)} \quad n = 0, 1, 2, \dots$$

In the special case,

$$f(x) = x e^{-x} - 0.2 \quad f'(x) = e^{-x} - x e^{-x}$$

$$\text{so that} \quad x_{n+1} = x_n - \frac{x_n e^{-x_n} - 0.2}{e^{-x_n} - x_n e^{-x_n}}$$

We choose $x_0 = 0.3$. Then

$$x_1 = 0.3 - \frac{0.3 e^{-0.3} - 0.2}{e^{-0.3} - 0.3 e^{-0.3}} = 0.25710251645$$

$$x_2 = 0.25710251645 - \frac{0.25710251645 e^{-0.25710251645} - 0.2}{e^{-0.25710251645} - 0.25710251645 e^{-0.25710251645}} = 0.25916608777$$

A summary of the computations is shown in Table 8.1. The remarkable thing is that after only four iterations, we obtain 15 digit accuracy. It is typical that the number of correct digits doubles on each step (underlined digits). By contrast, the bisection gets one new correct digit in roughly three steps. The bisection method requires 48 steps for comparable accuracy.

It would not have escaped Newton that the iteration

$$x_{n+1} = x_n - \frac{x_n e^{-x_n} - 0.2}{e^{-x_n} - x_n e^{-x_n}}$$

can be simplified to

$$x_{n+1} = x_n - \frac{x_n - 0.2 e^{x_n}}{1 - x_n} \tag{8.13}$$

Table 8.1: Matlab program to compute Newton iterates to solve $xe^{-x} - 0.2 = 0$. The underlined digits are accurate and the number of accurate digits doubles with each iteration.

MATLAB program	Output
<code>close all;clc;clear</code>	0.3000000000000000
<code>format long</code>	0. <u>257</u> 102516450287
<code>x=0.3</code>	0. <u>2591</u> 66087769089
<code>for k = 1:5</code>	0. <u>25917110</u> 1789536
<code>x = x - (x - 0.2*exp(x))/(1-x);</code>	0. <u>2591711018</u> 19074
<code>disp(x)</code>	0.259171101819074
<code>end</code>	

Newton’s method to solve $f(x) = 0$ requires three things. First it requires the derivative of f , but there is an alternate method that uses an average rate of change rather than the rate of change and works almost as well. Secondly, a good approximation to the root is required, and there is no substitute for that. Finally, in order to eliminate some unpleasant pathology, it is sufficient to assume that f , f' and f'' are continuous and that

$$\left| \frac{f(s) f''(s)}{(f'(s))^2} \right| < 1$$

These conditions are often met. ■

Exercises for Section 8.5, Finding roots to $f(x) = 0$.

Exercise 8.5.1 Try to solve $xe^{-x} = 0.2$ by iteration of $x_{n+1} = 0.2e^{x_n}$ beginning with $x_0 = 2.5$. This is easily done if your calculator has the ANS key. Enter 2.5. Then type $0.2 \times e^{\text{ANS}}$, ENTER, ENTER, \dots . Describe the result. Try again with $x_0 = 2.6$. Describe the result.

An alternate procedure is to solve for x as follows.

$$\begin{aligned}
 xe^{-x} &= 0.2 \\
 e^{-x} &= \frac{0.2}{x} \\
 -x &= \ln \frac{0.2}{x} \\
 x &= -\ln \frac{0.2}{x} = \ln(5x)
 \end{aligned}$$

Now let $x_0 = 2.5$ and iterate $x_{n+1} = \ln(5x_n)$ and describe your results.

Exercise 8.5.2 Use a calculator that has the ANS key and compute the iterates of Equation 8.13, using $x_0 = 0.3$. Use

0.3 ENTER ANS - (ANS - 0.2*e^(ANS))/(1-ANS) ENTER ENTER ENTER

Exercise 8.5.3 Begin with $x_0 = 0.25917110182$ and compute the iteration steps ($x_{n+1} = x_n e^{-x_n} - 0.2$). Describe your results.

Exercise 8.5.4 Refer to Figure 8.11B and use the bisection method to find the root to $f(x) = x e^{-x} - 0.2$ near $x = 2.5$.

Exercise 8.5.5 Use three steps of both the bisection method and Newton’s method to find the a value s in the indicated interval for which $f(s) = 0$ for

- a. $f(x) = x^2 - 2$ [1, 2]
- b. $f(x) = x^3 - 5$ [1, 2]
- c. $f(x) = x^2 + x - 1$ [0, 2]
- d. $f(x) = (x - \sqrt{2})^{1/3}$ [0, 1]

Exercise 8.5.6 Suppose you are trying to solve $f(x) = 0$ and for your first guess, x_0 , $f'(x_0) = 0$. Remember that x_1 is defined to be the point where the tangent to f at $(x_0, f(x_0))$ intersects the X -axis. What, if anything, is x_1 in this case?

Exercise 8.5.7 (A common example.) Use Newton’s Method to find the root of

$$f(x) = x^{\frac{1}{3}}$$

(Overlook the fact that the root is obviously 0!) Show that if $x_0 = 1$ the successive ‘approximations’ are 1, -2, 4, -8, 10, ...

Exercise 8.5.8 Ricker’s equation for population growth with proportional harvest is presented in Exercise 14.3.4 as

$$P_{t+1} - P_t = \alpha P_t e^{-P_t/\beta} - R P_t$$

If a fixed number is harvested each time period, the equation becomes

$$P_{t+1} - P_t = \alpha P_t e^{-P_t/\beta} - H$$

For the parameter values $\alpha = 1.2$, $\beta = 3$ and $H = 0.1$, calculate the positive equilibrium value of P_t .

8.6 Harvesting of whales.

The sei whale (pronounced ‘say’) is a well studied example of over exploitation of a natural resource. Because they were fast swimmers, not often found near shore, and usually sank when killed, they were not hunted until modern methods of hunting and processing at sea were developed. Reasonably accurate records of sei whale harvest have been kept. "...sei whale catches increased rapidly in the late 1950s and early 1960s (Mizroch et al., 1984c). The catch peaked in 1964 at over 20,000 sei whales, but by 1976 this number dropped to below 2,000 and the species received IWC protection in 1977." <http://spo.nwr.noaa.gov/mfr611/mfr6116.pdf>

Data shown in Figure 8.13 are from Joseph Horwood, *The Sei Whale: Population Biology, Ecology & Management*, Croom Helm, London, 1987.

The International Convention for Regulating Whaling was convened in 1946 and gradually became a force so that by 1963/64 effective limits on catches of blue and fin whales were in place because of depletion of those populations. As is apparent from the data, whalers turned to the sei

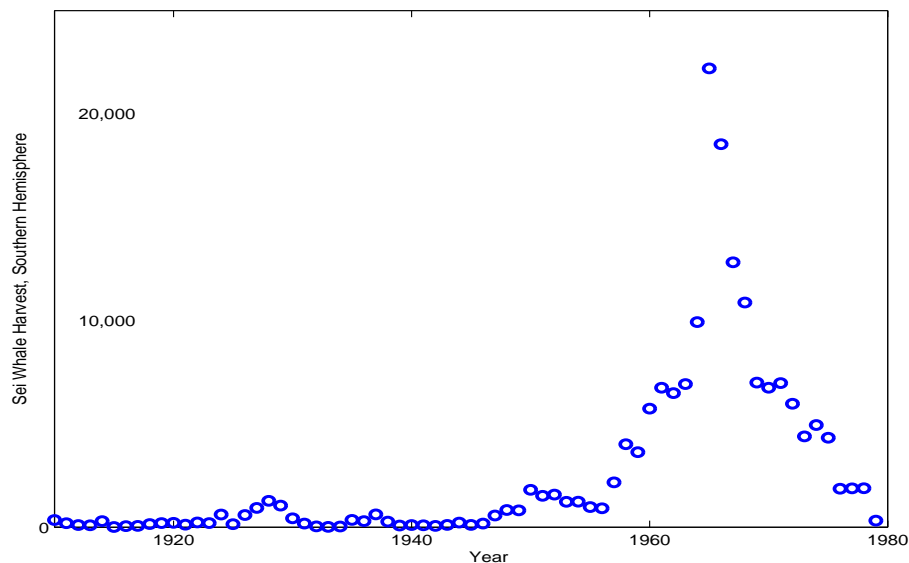

Figure 8.13: Harvest of Sei whales, southern hemisphere, 1910 - 1979.

whale in 1964-65, catching 22,205 southern hemisphere sei whales. Catches declined in the years 1965-1979 despite continued effort to harvest them, indicating depletion of the southern hemisphere stock. A moratorium on sei whale harvest was established in 1979. The **Maximum Sustainable Yield** (MSY) is an important concept in population biology, being an amount that can be harvested without eliminating the population.

Explore 8.6.1 Would you estimate that the southern hemisphere sei whale would sustain a harvest of 6000 whales per year?

The actual size of a whale population is difficult to measure. A standard technique is the ‘Mark and Recapture Method’, in which a number, N , of the whales is marked at a certain time, and during a subsequent time interval the number m of marked whales among a total of M whales sited is recorded.

Exercise 8.6.1 Suppose 100 fish in a lake are caught, marked, and returned to the lake. Suppose that ten days later 100 fish are caught, among which 5 were marked. How many fish would you estimate were in the lake?

Another method to estimate population size is the ‘Catch per Unit Effort Method’, based on the number of whale caught per day of hunting. As the population decreases, the catch per day of hunting decreases.

In the *Report of the International Whaling Commission (1978)*, J. R. Beddington refers to the following model of Sei whale populations.

$$N_{t+1} = 0.94N_t + N_{t-8} \left[0.06 + 0.0567 \left\{ 1 - \left(\frac{N_{t-8}}{N_*} \right)^{2.39} \right\} \right] - 0.94C_t \quad (8.14)$$

N_t , N_{t+1} and N_{t-8} represent the adult female whale population subjected to whale harvesting in years t , $t + 1$, and $t - 8$, respectively. C_t is the number of female whales harvested in year t . There is an assumption that whales reach sexual maturity and are able to reproduce at eight years of age

and become subject to harvesting the same year that they reach sexual maturity. The whales of age less than 8 years are not included in N_t . N_* is the number of female whales that the environment would support with no harvesting taking place.

Exercise 8.6.2 Show that if there is no harvest ($C_t = 0$) and both N_t and N_{t-8} are equal to N_* then $N_{t+1} = N_*$.

If we divide all terms of Equation 8.14 by N_* , we get

$$\frac{N_{t+1}}{N_*} = 0.94 \frac{N_t}{N_*} + \frac{N_{t-8}}{N_*} \left[0.06 + 0.0567 \left\{ 1 - \left(\frac{N_{t-8}}{N_*} \right)^{2.39} \right\} \right] - 0.94 \frac{C_t}{N_*}$$

We might define new variables, $D_t = \frac{N_t}{N_*}$ and $E_t = \frac{C_t}{N_*}$ and have the equation

$$D_{t+1} = 0.94D_t + D_{t-8} \left[0.06 + 0.0567 \left\{ 1 - D_{t-8}^{2.39} \right\} \right] - 0.94E_t \quad (8.15)$$

Equation 8.15 is simpler by one parameter (N_*) than Equation 8.14 and yet illustrates the same dynamical properties. Rather than use new variables, it is customary to simply rewrite Equation 8.14 with new interpretations of N_t and C_t and obtain

$$N_{t+1} = 0.94N_t + N_{t-8} \left[0.06 + 0.0567 \left\{ 1 - N_{t-8}^{2.39} \right\} \right] - 0.94C_t \quad (8.16)$$

N_t now is a fraction of N_* , the number supported without harvest, and C_t is a fraction of N_* that is harvested.

Equation 8.14 says that the population in year $t + 1$ is affected by three things: the number of female whales in the previous year (N_t), the “recruitment” of eight year old female whales into the population subject to harvest, and the harvest during the previous year (C_t).

- Exercise 8.6.3**
- Suppose $N_* = 250,000$ and a quota of 500 female whales harvested each year is established. Change both Equations 8.14 and 8.16 to reflect these parameter values.
 - Suppose 2% of the adult female whale population is harvested each year. Change both Equations 8.14 and 8.16 to reflect this procedure.
 - What is the meaning of 0.94 at the two places it enters Equation 8.16?

The term

$$N_{t-8} \left[0.06 + 0.0567 \left\{ 1 - (N_{t-8})^{2.39} \right\} \right]$$

represents the number of eight year old females recruited into the adult population in year, t . The factor,

$$\left[0.06 + 0.0567 \left\{ 1 - (N_{t-8})^{2.39} \right\} \right]$$

represents the fecundity of the females in year $t - 8$. It has been observed that as whale numbers decrease, the fecundity increases. This term was empirically determined by Beddington.

Exercise 8.6.4 Draw the graph of fecundity *vs* N_{t-8} .

Exercise 8.6.5 Suppose harvest level, C_t is set at a constant level, C for a number of years. Then the whale population should reach an equilibrium level, N_e , and approximately

$$N_{t+1} = N_t = N_{t-8} = N_e$$

We would like to have N_e as a function of the harvest level, C . This is a little messy (actually quite a bit messy), but it is rather easy to write the inverse function, C as a function of N_e .

- Let $C_t = C$ and $N_{t+1} = N_t = N_{t-8} = N_e$ in Equation 8.16 and solve the resulting equation for C . Draw the graph of C vs N_e .
- Find a point on the graph of $C(N_e)$ at which the tangent to the graph is horizontal.
- If you did not do it in the previous step, compute $C'(N_e) = \frac{dC}{dN_e}$ and find a value of N_e for which $C'(N_e)$ is zero.
- Give an interpretation of the point $(N_e, C(N_e)) = (0.60001, 0.025507)$. What do you suppose happens if the constant harvest level is set to $C = 0.03$?
- N_* for the southern hemisphere sei whale has been estimated to be 250,000. If N_* is 250,000, what is the maximum harvest that will lead to equilibrium? You should find that the maximum supportable yield of the southern hemisphere sei whale is about 6000 whales per year.

Exercise 8.6.6 In this problem, you will gain some experience with the solution to Equation 8.16 for several values of the parameters. You should record the behavior of the solutions for different parameter values. You may wish to use the MATLAB program

```
close all;clc;clear
C=0.0255; S=0.61; iter = 150; space = 5
for k = 1:9
    N(k)=S;
end
for k = 10:iter
    N(k) = 0.94*N(k-1)+N(k-9)*(0.06+0.0567*(1-N(k-9)^(2.39)))-0.94*C;
end
N(10:space:iter)'
```

- Run the program. What happens to the whale population?
- Change $S = 0.61$ to $S = 0.59$, and run again. What happens to the whale population?
- Change $C = 0.0255$ to $C = 0.023$ and run again. What happens to the whale population?
- Find the values of N_e that correspond to $C = 0.023$. Suggestion: a. Iterate $x_0 = 0.5$, $x_{n+1} = 0.3813 + x_n^{3.39}$. b. Iterate $x_0 = 0.5$, $x_{n+1} = (x_n - 0.3813)^{(1/3.39)}$.
- Use $C = 0.0230$ and $S = 0.43$ and run again. What happens to the whale population?
- Change $S = 0.43$ to $S = 0.45$ and run again. What happens to the whale population?
- Change $S = 0.45$ to $S = 0.78$ and run again. What happens to the whale population?

8.7 Summary and review of Chapters 3 to 8.

Definitions. We have introduced the concepts of *difference quotient* of a function and *rate of change* of a function, and applied the concepts to polynomial, exponential and logarithm functions and trigonometric functions. The difference quotient of a function is:

$$\text{Difference quotient of } P \text{ on } [a, b] = \frac{P(b) - P(a)}{b - a}$$

where P is a function whose domain contains at least the numbers a and b .

To compute the rate of change of P at a number a in the domain of P , we compute the difference quotient of P over intervals, $[a, b]$, having a as one endpoint and decreasing in size to zero. Then there is that mysterious step of deciding what those difference quotients get close to as b gets close to a . Assuming the difference quotients get close to some number, that number is called the rate of change of P at a and is denoted by $P'(a)$.

The symbol, P' , denotes the function defined by

$$P'(a) = \text{the rate of change of } P \text{ at } a$$

for every number a in the domain for which the rate of change exists.

The words ‘get close to’ are sometimes replaced with ‘approaches’, and the word ‘limit’ is used for the number that $(P(b) - P(a))/(b - a)$ gets close to. This can reduce a lot of words to a simple symbol,

$$P'(a) = \lim_{b \rightarrow a} \frac{P(b) - P(a)}{b - a} \quad (8.17)$$

Chapter Exercise 8.7.1 Let $P(t) = \sqrt{t}$ and a be a positive number. Give reasons for the following steps to find $P'(a)$.

$$P'(a) = \lim_{b \rightarrow a} \frac{P(b) - P(a)}{b - a} \quad (i)$$

$$= \lim_{b \rightarrow a} \frac{\sqrt{b} - \sqrt{a}}{b - a} \quad (ii)$$

$$= \lim_{b \rightarrow a} \frac{1}{\sqrt{b} + \sqrt{a}} \quad (iii)$$

$$= \frac{1}{\sqrt{a} + \sqrt{a}} = \frac{1}{2\sqrt{a}} \quad (iv)$$

Chapter Exercise 8.7.2 Suppose $P(t) = t^4$.

- Write an expression for $(P(b) - P(a))/(b - a)$, the difference quotient of P on the interval, $[a, b]$.
- Simplify your expression.
- Use your simplified expression to show that the rate of change of P at a is $4a^3$.

Chapter Exercise 8.7.3 Use the definition of rate of change to find the rate of change of $P(t) = \frac{1}{t}$ at $a = 5$. Repeat for a unspecified. Complete the formula

$$P(t) = \frac{1}{t} \quad \Rightarrow \quad P'(t) =$$

The functions F and G of the next two exercises present interesting challenges.

Chapter Exercise 8.7.4 Nine points of the graph of the function F defined by

$$F\left(\frac{1}{\sqrt{n}}\right) = \frac{(-1)^n}{n} \quad \text{for } n = 1, 2, 3, \dots \quad (8.18)$$

$$F(0) = 0$$

are shown in Chapter Exercise Figure 8.7.4a.

- a. Plot two more points of the graph of F .
- b. Does $F'(0)$ exist?
- c. Does the graph of F have a tangent at $(0,0)$? Your vote counts.

Figure for Chapter Exercise 8.7.4 Graphs of F and G for Chapter Exercises 8.7.4 and 8.7.5.

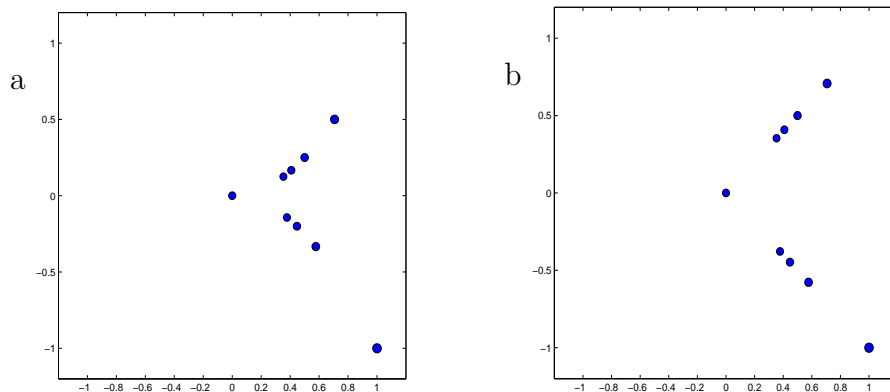

Chapter Exercise 8.7.5 Nine points of the graph of the function G defined by

$$G\left(\frac{1}{\sqrt{n}}\right) = \frac{(-1)^n}{\sqrt{n}} \quad \text{for } n = 1, 2, 3, \dots \tag{8.19}$$

$$G(0) = 0$$

are shown in Chapter Exercise Figure 8.7.4b.

- a. Plot two more points of the graph of G .
- b. Does $G'(0)$ exist?
- c. Does the graph of G have a tangent at $(0,0)$? Your vote counts.

8.7.1 Derivative Formulas.

Using the definition of rate of change, we obtained formulas for derivatives of six functions.

Primary Formulas

$$[C]' = 0 \tag{8.20} \qquad [\ln t]' = \frac{1}{t} \tag{8.23}$$

$$[t^c]' = ct^{c-1} \tag{8.21} \qquad [\sin t]' = \cos t \tag{8.24}$$

$$[e^t]' = e^t \tag{8.22} \qquad [\cos t]' = -\sin t \tag{8.25}$$

Then we obtained rules for derivatives of combinations of functions.

Combination Rules

$$[C u(t)]' = C u'(t) \quad (8.26)$$

$$[u(t) + v(t)]' = u'(t) + v'(t) \quad (8.27)$$

$$[u(t) v(t)]' = u'(t) v(t) + u(t) v'(t) \quad (8.28)$$

$$\left[\frac{u(t)}{v(t)} \right]' = \frac{v(t) u'(t) - u(t) v'(t)}{(v(t))^2} \quad (8.29)$$

$$[G(u(t))]' = G'(u(t)) u'(t) \quad (8.30)$$

Formula 8.30, ($[G(u(t))]' = G'(u(t)) u'(t)$, called the chain rule) is a bit difficult for students, and special cases were presented.

Chain Rule Special Cases

$$[(u(t))^n]' = n (u(t))^{n-1} u'(t) \quad (8.31)$$

$$[e^{u(t)}]' = e^{u(t)} u'(t) \quad (8.32)$$

$$[\ln(u(t))]' = \frac{1}{u(t)} u'(t) \quad (8.33)$$

$$[\sin(u(t))]' = \cos(u(t)) u'(t) \quad (8.34)$$

$$[\cos(u(t))]' = -\sin(u(t)) u'(t) \quad (8.35)$$

One special case of the chain rule is so important to the biological sciences that it requires individual attention.

$$[e^{kt}]' = e^{kt} k = k e^{kt} \quad (8.36)$$

Example 8.7.1 Usually more than one derivative formula may be used in a single step toward computing a derivative. It is important to know which steps are being used, and a slow but sure way to insure proper use is to use but a single formula for each step. We illustrate with

$$P(t) = [e^{t^2} + e^{-t}]^4.$$

$$\begin{aligned} P'(t) &= \left[[e^{t^2} + \sin t]^4 \right]' && \text{Notational identity.} \\ &= 4 [e^{t^2} + \sin t]^3 [e^{t^2} + \sin t]' && \text{Equation 8.31} \\ &= 4 [e^{t^2} + \sin t]^3 \left([e^{t^2}]' + [\sin t]' \right) && \text{Equation 8.27} \\ &= 4 [e^{t^2} + \sin t]^3 \left(e^{t^2} [t^2]' + [\sin t]' \right) && \text{Equation 8.32} \\ &= 4 [e^{t^2} + \sin t]^3 \left(e^{t^2} (2t) + [\sin t]' \right) && \text{Equation 8.21} \\ &= 4 [e^{t^2} + \sin t]^3 \left(e^{t^2} (2t) + \cos t \right) && \text{Equation 8.24.} \end{aligned}$$

Observe that the the first three steps used combination formulas; the last two steps involved primary formulas. A common pattern.

Chapter Exercise 8.7.6 Use the derivative formulas, one formula for each step, to find $P'(t)$ for

$$\begin{array}{ll} \text{a. } P(t) = t^5 + 3t^4 - 5t^2 + 7 & \text{b. } P(t) = t^3 e^{6t} \\ \text{c. } P(t) = [1 + t^2]^3 & \text{d. } P(t) = \sin t^2 \\ \text{e. } P(t) = \sin^2 t & \text{f. } P(t) = \ln t^7 \\ \text{g. } P(t) = e^{\sin t} & \text{h. } P(t) = \cos 5t \\ \text{i. } P(t) = \frac{\sin t}{\cos t} & \text{j. } P(t) = \frac{t}{t^2 + 1} \end{array}$$

Chapter Exercise 8.7.7 Compute the derivatives of

$$\begin{array}{ll} \text{a. } P(t) = t^5 + 3t^4 - 4t^2 + 1 & \text{b. } P(t) = t^{-3} \\ \text{c. } P(t) = t^4 e^t & \text{d. } P(t) = (t + e^t)^4 \\ \text{e. } P(t) = \frac{1}{t^2 + 1} & \text{f. } P(t) = \ln(t^2 + 1) \\ \text{g. } P(t) = e^{-3t} - e^{-5t} & \text{h. } P(t) = e^{-t^2} \end{array}$$

Chapter Exercise 8.7.8 The word *differentiate* means ‘find the derivative of’. Differentiate

- | | |
|---------------------------------|-----------------------------|
| a. $P(t) = \frac{e^{-3t}}{t^2}$ | b. $P(t) = e^{2 \ln t}$ |
| c. $P(t) = e^t \ln t$ | d. $P(t) = t^2 e^{2t}$ |
| e. $P(t) = e^{t \ln 2}$ | f. $P(t) = e^2$ |
| g. $P(t) = [e^t]^5$ | h. $P(t) = \ln e^{3t}$ |
| k. $P(t) = \frac{1}{\ln t}$ | l. $P(t) = [\sin \pi t]^5$ |
| m. $P(t) = \sin(\cos t)$ | n. $P(t) = \frac{t}{t^2+1}$ |

8.7.2 Applications of the derivative

Geometry. The rate of change of $P(t)$ at a is the slope of the tangent to the graph of P at the point $(a, P(a))$. With only one exception, the existence of a tangent to the graph of P at $(a, P(a))$ is equivalent to the existence of the rate of change of $P(t)$ at a . The exception is illustrated by

Chapter Exercise 8.7.9 Let $P(t) = t^{\frac{1}{3}}$.

- Draw the graph of P on $-1 \leq t \leq 1$.
- Draw the tangent to the graph of P at $(0,0)$.
- For $(a, P(a)) = (0,0)$, compute $(P(b) - P(a))/(b - a)$.
- Discuss $\lim_{b \rightarrow 0} (P(b) - P(0))/(b - 0)$.

Chapter Exercise 8.7.10 Find an equation of the line tangent to the graph of $P(t) = e^t$ at the point $(1, e^1) = (1, e)$.

The tangent line lies close to the graph near the point of tangency, and is often used as an easily computable approximation to the graph. The next problem illustrates this.

Chapter Exercise 8.7.11 In Problem 8.7.10 you found the equation of the line tangent to the graph of $P(t) = e^t$ at the point $(1, e)$. Let y_x denote the y -coordinate of the point on the tangent whose x -coordinate is x .

- Find $y_{1.8}$.
- Compute $e^{1.8}$.
- Compute the relative error

$$\frac{y_{1.8} - e^{1.8}}{e^{1.8}}$$

- Mark the points $(1.8, P(1.8))$ and $(1.8, y_{1.8})$ on a copy of the graph in Figure 8.7.11A.
- Find $y_{1.1}$.
- Compute $e^{1.1}$.

g. Compute the relative error

$$\frac{y_{1.1} - e^{1.1}}{e^{1.1}}$$

h. Mark the points $(1.1, P(1.1))$ and $(1.1, y_{1.1})$ on a copy of the graph in Figure 8.7.11B.

Figure for Chapter Exercise 8.7.11 Graphs of $y = e^x$ and its tangent at $(1, e)$ at two scales.

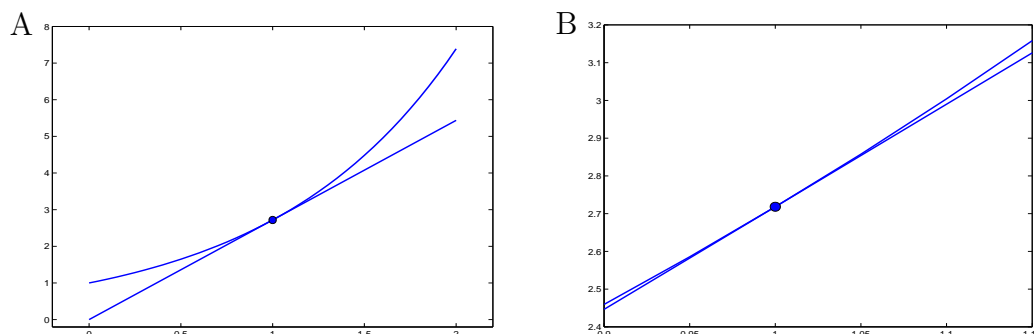

Chapter Exercise 8.7.12 Let $P(t) = t^3 + 6t^2 + 9t + 5$. Find the intervals on which $P'(t) > 0$. If you draw the graph of P on your calculator, you will observe that P is increasing on these same intervals.

Chapter Exercise 8.7.13 Find an equation of the line tangent to the graph of $P(t) = t^3 - 3t^2 + 5$ at the point $(1, 3)$. Find a point on the graph of P at which the tangent to the graph is horizontal.

8.7.3 Differential Equations

With each of the derivative formulas we found equations involving those derivatives (called differential equations) that describe dynamics of some biological systems.

Chapter Exercise 8.7.14 We will find in Chapter 17 that a population of size, $P(t)$, growing in a limited environment of size, M , is modeled by an equation of the form

$$P'(t) = k P(t) \left(1 - \frac{P(t)}{M} \right),$$

and that $P(t)$ can be written explicitly as

$$P(t) = \frac{P_0 M e^{kt}}{M - P_0 + P_0 e^{kt}}$$

where P_0 is the population size at time $t = 0$.

Assume $P_0 = 1$, $M = 10$, and $k = 0.1$.

- Use the first equation and draw a graph of P' vs P .
- What value of P maximizes P' ?
- Use the second equation and draw the graph of $P(t)$.
- Draw a tangent to the graph of P at the point for which P' is a maximum. Is the point an inflection point?

e. Rewrite your equation to be

$$P(t) = \frac{10}{9e^{-0.1t} + 1} = 10 \left(9e^{-0.1t} + 1\right)^{-1}$$

and compute $P'(t)$.

f. At what time t and population size, $P(t)$, is $P'(t)$ a maximum?

Chapter Exercise 8.7.15 Heavy rainfall in the drainage area of a lake causes runoff into the lake at the rate of $100e^{-t}$ acre-feet per day. The accumulated runoff into the lake due to the rain after t days is $100(1 - e^{-t})$ acre feet. Water is released from the lake at the rate of 20 acre-feet per day and the volume of the lake at the time of the rain was 400 acre-feet. Flood stage is 450 acre-feet.

a. Write an equation for the volume, $V(t)$ of water in the lake at time t days after the rain, accounting for the initial volume, the volume accumulated due to the rain, and the total volume released during the t days.

b. Does the lake flood?

c. At what time does the lake reach its maximum volume and what is the maximum volume?

Chapter Exercise 8.7.16 This exercise explores the optimum clutch size for a bird. Most biological parameters are compromise values that optimize some feature of the system. In this model, we assert that clutch size of birds is adapted to maximize the number of birds that survive for three months past hatching. The data is for a chickadee, *Parus major*, as observed in woods near Oxford, England⁶. This is part of a historic study of the chickadee population in those woods begun in 1947 and from which data are still being gathered. Only two of the several factors influencing clutch size are considered here, the weight, WT of the young at age 15 days in a clutch of size n , and the percent of fledglings recovered 3 months past fledging. The data is for the year 1961. In order to have several young survive to age three months, a large clutch should be produced. However, if the clutch is too large the adults can not adequately feed the young, they are small at fledging, and the probability of survival is reduced. The following exercises explore the relations between the parameters.

The basic data is displayed in Chapter Exercise Figure 8.7.16 along with the following parabolas that approximate the data:

$$WT = -0.024(BD - 3.25)^2 + 19.2 \quad (8.37)$$

$$PCT = 0.75(W - 15)^2 \quad (8.38)$$

WT is the average weight at 15 days of chicks in a clutch of size BD , and PCT is the percent of chicks of weight W at 15 days that survive to 90 days.

Figure for Chapter Exercise 8.7.16 Data and quadratic approximations for chickadees. A. Graph of average body weight *vs* clutch size. B. Graph of percent survival to 90 days *vs* body weight of chick. $WT \doteq -0.024(BD - 3.25)^2 + 19.2$ and $PCT \doteq 0.75(W - 15)^2$.

⁶C. M. Perrins, Population fluctuations and clutch-size in the great tit, *PARUS MAJOR L.*, *J. Animal Ecol.* **34** 601-647 (1965)

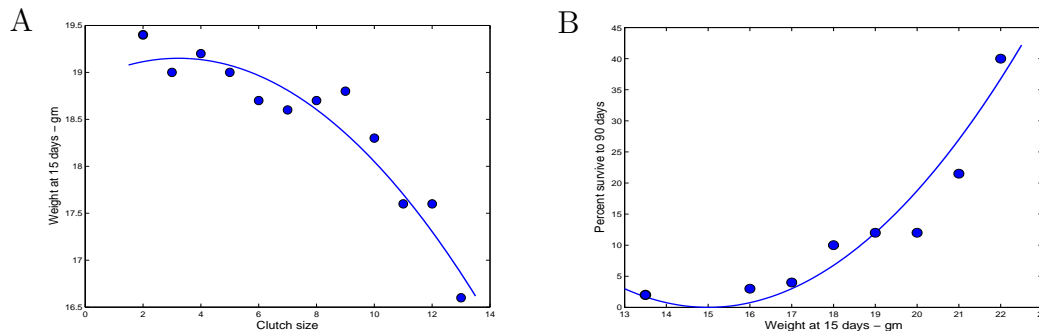

We make an assumption that the expected number, XP , of chicks that survive to age 90 days from a clutch size of BD is

$$XP = BD PCT/100. \tag{8.39}$$

The distribution of weights of chicks at 15 days within a clutch is unknown to us; we are assuming that $W = WT$, an assumption we would prefer to avoid.

- Assume that $W = WT$ and use Equations 8.37 and 8.38 to write a single equation for PCT in terms of BD .
- Now use Equation 8.39 to write XP in terms of BD .
- Use simpler notation.

$$y = x 0.0075 \times 0.024^2 \left[(x - 3.25)^2 - 175 \right]^2$$

Use derivative formulas to compute y' .

- One factor of y' is $5x^2 - 19.5x - 164.4375$. Find a value of x between 6 and 10 for which $y'(x) = 0$.
- How many chicks from a brood of optimum size would be expected to survive?

You should have found that a clutch size of 8.0 will maximize the expected number of chicks that will survive to 90 days. From table 14 of Perrins, 383 broods had an average brood size of 8.1 chicks.

Chapter 9

The Integral

Where are we going?

In this chapter we will use the familiar concept of the area of a rectangle to form approximations to areas of regions that are of non-rectangular shape. The regions of greatest immediate interest are regions lying between the graph of a function and the horizontal axis. The areas of such regions have important uses such as the accumulated deposit of a chemical or waste product, the distance traveled by an object, measurement of cardiac output, and the average value of a function.

Four rectangles approximating an irregular region

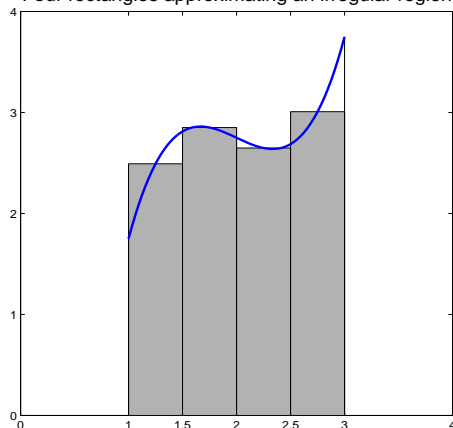

9.1 Areas of Irregular Regions.

Area of an oak leaf.

Explore 9.1.1 Describe two ways to approximate the area of the leaf shown in Figure 9.1. ■

You may think of several interesting ways of solving the previous problem. A way that we will generalize to future applications is illustrated by two problems following Figure 9.1.

One of the more curious ways of estimating the area of the leaf in Figure 9.1 is to paste the page on a dart board and throw darts at the page from a distance sufficient to insure that the points where the dart hits the page are randomly distributed on the page. The number, N_P , of darts that strike the page and the number, N_L , of darts that strike the leaf can be counted. The area of the leaf is approximated by

$$\text{Area of the leaf} \doteq \frac{N_L}{N_P} \text{Area of the page.}$$

Although the procedure may seem a bit esoteric, it is used in serious computations of volumes in high dimension (with points randomly generated by a computer algorithm rather than darts!).



Figure 9.1: An Oak leaf.

Explore 9.1.2 The darker grid lines in Figure 9.2 are marked at 1.0 cm intervals. Count the number I_1 of 1.0 cm² squares entirely covered by the leaf and the number O_1 of 1.0 cm² squares that intersect the leaf (including those included in I_1). Use I_1 and O_1 to estimate the area of the leaf. ■

The finer grid on the leaf in Figure 9.2 is marked at 0.5 cm intervals. We count that $I_2 = 283$ of these squares are completely inside the leaf and a total of $O_2 = 409$ squares intersect the leaf (not including the stem). Because each square is of area 0.25 cm² the area of the leaf should be at least $283 \times 0.25 = 70.75$ cm² and no more than $409 \times 0.25 = 102.25$ cm².

Explore 9.1.3 How do 70.75 and 102.25 cm² compare with your answer based on the 1 cm² squares? Given the information so far obtained, what is your best estimate of the area of the leaf? How can you extend the procedure to get an even better answer? ■

Let A denote the area of the leaf in Figure 9.2. Because the area of each 1cm grid square is 1cm², $I_1 \times 1$ is the area of the region covered by the the 1cm grid squares inside the leaf, and $I_1 \times 1$ is less than A . Because the squares that intersect the leaf enclose the leaf, $O_1 \times 1$ is greater than A .

Explore 9.1.4 Because every 1-cm square inside the leaf contains four 0.5-cm squares *also inside the leaf*,

$$I_1 \times 1.0 \leq I_2 \times 0.25.$$

Explain why

$$\text{a. } I_2 \times 0.25 \leq A \leq O_2 \times 0.25 \quad \text{b. } O_2 \times 0.25 \leq O_1 \times 1.0. \quad \blacksquare$$

■

The normal distribution. Shown in Figure 9.3 is (a portion of) the graph of the probability density function of the normal distribution, sometimes called the ‘Bell-shaped curve’. In the figure shown, the distribution has mean zero and standard deviation equal to one. The equation of the density function is

$$f(x) = \frac{1}{\sqrt{2\pi}} e^{-\frac{x^2}{2}} \quad -\infty < x < \infty \quad (9.1)$$

The interpretation of the density function is that if a measurement of a sample from a normal variate has been scaled so that the average value is zero and the standard deviation is one, then for any interval $[a, b]$ of measurement values, the probability that any one member of the sample lies in $[a, b]$ is the area of the region between $x = a$ and $x = b$ and below the curve and above the horizontal axis. The area under the total curve, from $-\infty$ to $+\infty$, is 1.0. The graph is symmetrical about the Y-axis, so that, for example, the area to the left of the vertical axis is equal to the area to the right of the vertical axis, the two areas sum to one, and therefore both areas are 0.5.

The normal distribution is important because many biological measurements (heights of European women, lengths of ears of a certain variety of corn) are approximately normally distributed about their means. Such quantities are thought to be essentially the sum of a large number of independent small quantities (determined by genetic factors that have additive effects), which would account for the cumulative effect being normally distributed. Also, for *any* distribution, the means of repeated samples from the distribution are approximately normally distributed. For example, if you randomly select 50 people from a given population and compute the mean of their heights, and repeat this experiment 100 times, then the 100 means so computed will be approximately normally distributed.

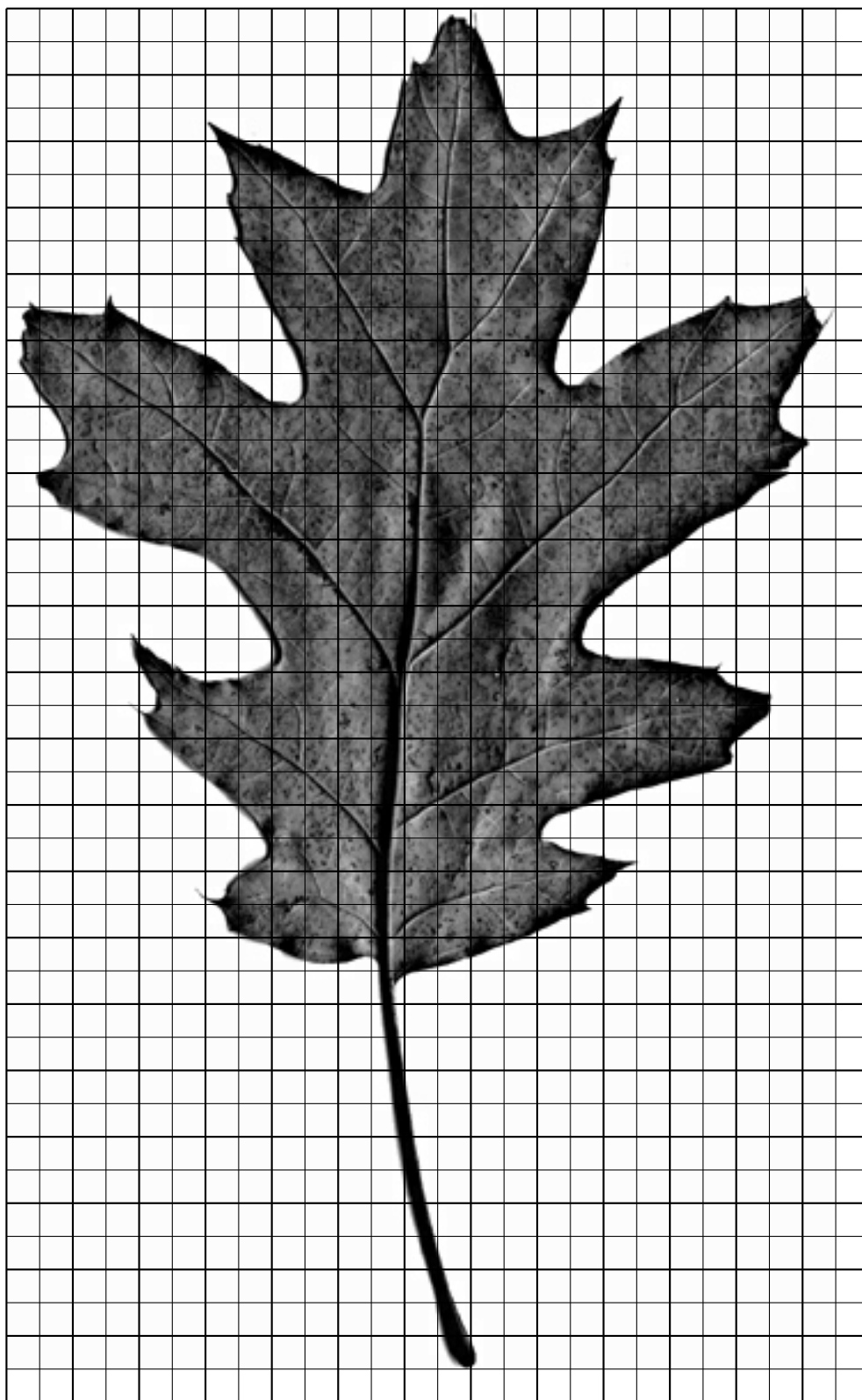

Figure 9.2: An Oak leaf with 1cm and 0.5cm grids.

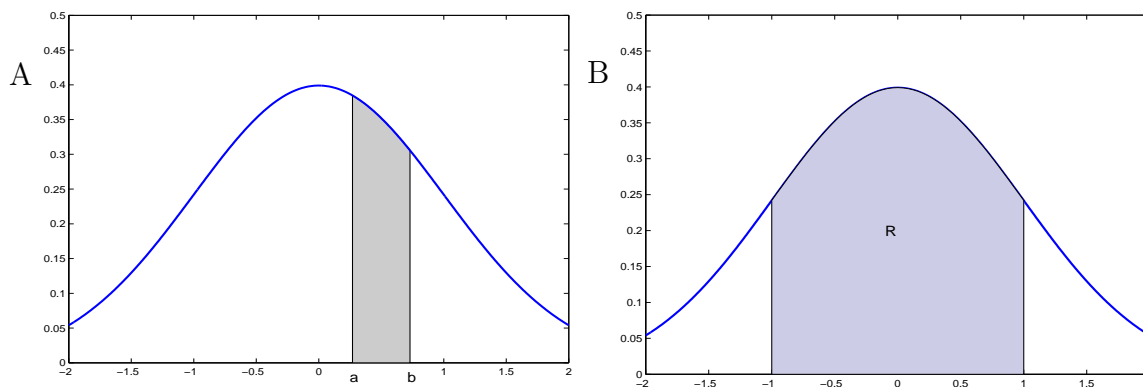

Figure 9.3: A. A graph of a portion of the particular normal distribution that has mean zero and standard deviation one, Equation 9.1, $f(x) = \frac{1}{\sqrt{2\pi}} e^{-x^2/2}$. The probability that a number drawn from this normal distribution lies in the interval $[a, b]$ is the area of the shaded region below the graph and above $[a, b]$. B. The shaded region, R , is bounded by the graph of the normal distribution, the X-axis, and the vertical lines $x = -1$ and $x = 1$.

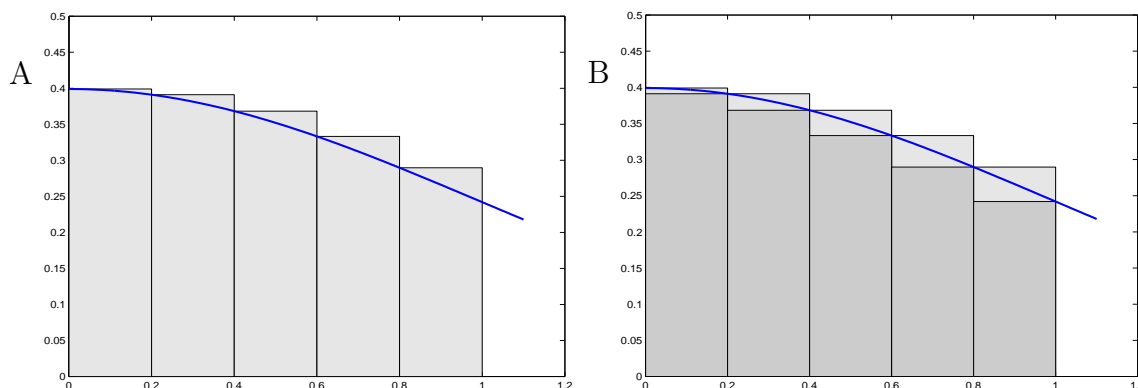

Figure 9.4: Graphs of the normal distribution density function, $f(x) = \frac{1}{\sqrt{2\pi}} e^{-x^2/2}$, between $x = 0$ and $x = 1$. A. Upper rectangle approximation to the area between the graph of the curve and the X-axis and the lines $x = 0$ and $x = 1$. B. Same as A with lower rectangles included.

Example 9.1.1 Problem: Find (approximately) the area of the region R in Figure 9.3B bounded by the graph of the normal distribution, f , the X-axis, the vertical line, $x = -1$ and the vertical line, $x = 1$.

Solution:

1. Because of the symmetry of the region R about the Y -axis, it is sufficient to find the area of that portion of R that is to the right of the Y -axis, and then to multiply by 2. The portion R to the right of the Y -axis is shown in Figure 9.4A.
2. Compute the sum of the areas of the upper rectangles in Figure 9.4A. The width of each rectangle is 0.2 and the heights of the rectangles are determined by the density function, f . The area of the leftmost rectangle, based on the X interval $[0, 0.2]$, is

$$f(0) \times 0.2 = \frac{1}{\sqrt{2\pi}} e^{-\frac{0^2}{2}} \times 0.2 = 0.079788$$

The area of the second rectangle from the left, based on the X interval $[0.2, 0.4]$, is

$$f(0.2) \times 0.2 = \frac{1}{\sqrt{2\pi}} e^{-\frac{0.2^2}{2}} \times 0.2 = 0.078209$$

Explore 9.1.5 Find the areas of the remaining three rectangles in Figure 9.4A. ■

- The sum of the areas of the five rectangles is 0.356234; twice the sum is 0.712469. This is an over estimate of the area of R .
- An under estimate of the area can be computed by summing the areas of the lower rectangles in Figure 9.4B. The leftmost lower rectangle, based on the X interval $[0, 0.2]$ has the same area as the second upper rectangle from the left, based on the X interval $[0.2, 0.4]$, and we computed that area to be 0.078209. The next three rectangles are similarly related to upper rectangles, and their areas are precisely the areas you computed in the preceding problem.

The area of the right most lower rectangle is

$$\frac{1}{\sqrt{2\pi}} e^{-\frac{1^2}{2}} \times 0.2 = 0.07358$$

and the sum of the five areas is 0.324840; twice the sum is 0.649680.

- We now know that the area of R , is greater than 0.649680 and less than 0.712469. A good estimate of the area of R is the average of these two bounds,

$$\frac{0.649680 + 0.712469}{2} = 0.681075.$$

The probability of being within one standard deviation of the mean in a normal distribution is 0.68268949 correct to eight digits.

■

Ozone: The Alfred Wegner Institute Foundation for Polar and Marine Research, Bremerhaven Germany, has measured (among a large number of interesting things) ozone partial pressures at altitudes up to 35,000 meters since March 1992 at their Georg von Neumayer research Station in the Antarctic. Two relevant web sites are:

<http://www.awi-bremerhaven.de/>

http://www.awi.de/en/infrastructure/stations/neumayer_station/

[observatories/meteorological_observatory/upper_air_soundings/ozone_soundings/](http://www.awi.de/en/infrastructure/stations/neumayer_station/observatories/meteorological_observatory/upper_air_soundings/ozone_soundings/)

Color graphs at the site show the ozone history since 1992. An image for 2004 is shown in Figure 9.5. Data read from that graph for the ozone partial pressure as a function of altitude on day 100 is shown in Table 9.1.

Assume that the “ozone layer” lies between 14 and 28 kilometers. and that the density of the ozone is proportional to the partial pressure (which would be OK were the temperature constant). We ask, how much ozone is in the ‘ozone layer’ on day 100 above the Neumayer station? More specifically, we assume that the density of ozone in grams per kilometer cubed is a constant, K , times the partial pressure of ozone and ask how much ozone is in a column that is above a 100

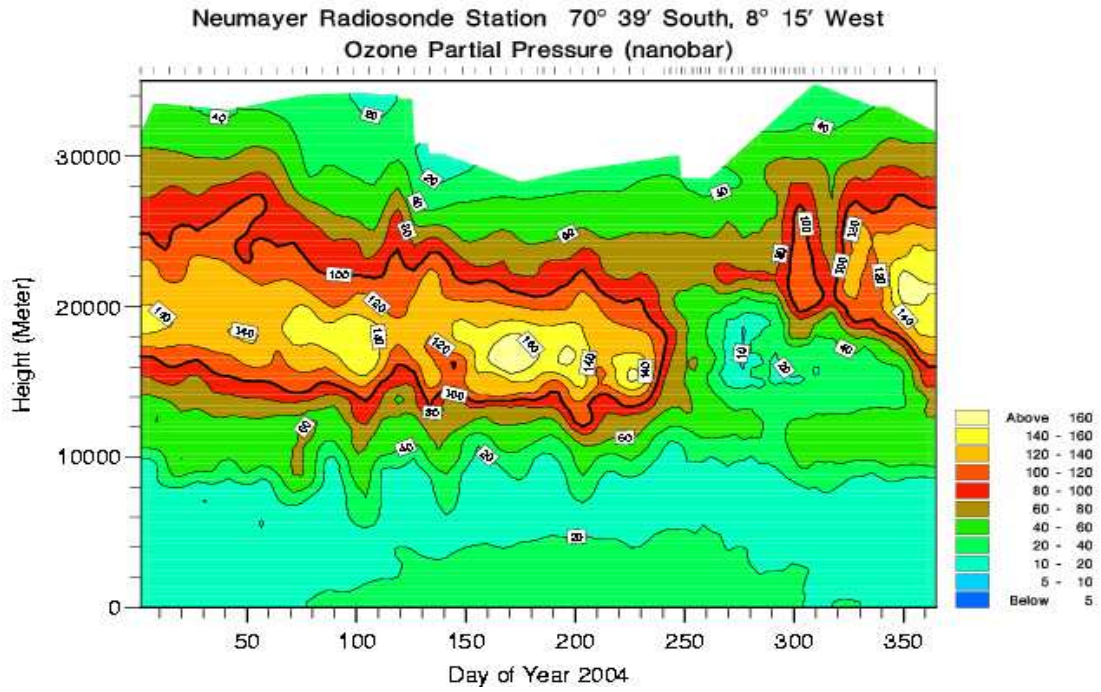
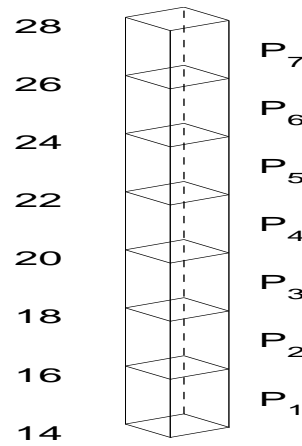

Figure 9.5: Ozone partial pressure at the Neumayer Station.

Table 9.1: Data read from Figure 9.5 for day 100.

Day 100	
Ht km	Ozone pp
28	40
26	60
24	80
22	100
20	130
18	150
16	150
14	100



meters (=0.1 km) by 100 meters square that surrounds the Neumayer antarctic station and between the altitudes 14 and 28 kilometers (see the diagram in Table 9.1).

Consider first that portion, P_1 , of the column between 14 and 16 km. The volume of P_1 is

$$0.1 \times 0.1 \times 2 \text{ km}^3 = 0.02 \text{ km}^3$$

The ozone density at 14 km is $K \times 60$ and at 16 km is $K \times 90$ gm/km³. We assume that the average density for all of P_1 is the average of $K \times 60$ and $K \times 90$, or $K \times 75$ gm/km³.

Then the mass of ozone in P_1 is calculated as

$$\text{Mass of ozone in } P_1 = 0.02 \text{ km}^3 \times K \times 75 \text{ gm/km}^3 = K \times 1.5 \text{ gm}$$

Similarly we calculate the mass of ozone in the portion, P_2 , of the column:

$$\text{Mass of ozone in } P_2 = 0.02 \text{ km}^3 \times K \times \frac{90 + 115}{2} \text{ gm/km}^3 = K \times 2.05 \text{ gm}$$

Continuing we get the mass of ozone in the section of the column above Neumayer station to be $13.7 K$ gm.

Exercises for Section 9.1, Areas of Irregular Regions.

Exercise 9.1.1 Find (approximately) the area of the region in Figure 9.3 bounded by the graph of the normal distribution, f , the X-axis, the vertical line, $x = -2$ and the vertical line, $x = 2$.

Because we found the area of the region R bounded by $x = -1$ and $x = 1$ you might reasonably conclude that your main task is to find the area of the region bounded by the graph of the normal distribution, the X-axis, the lines $x = 1$ and $x = 2$. Then add some numbers.

You should find that the probability of being within two standard deviations of the mean of the normal distribution is approximately 0.95 (the probability is 0.95449974 correct to eight digits).

Exercise 9.1.2 Shown in Figure 9.6A are the hourly readings for solar radiation intensity for June 21, 2004 recorded by the University of Oregon Solar Radiation Monitors Laboratory at their station in Eugene, Oregon (<http://solardat.uoregon.edu>). The data are for 'global irradiance' which includes all radiation falling on a horizontal plate measured in watts/meter².

The data in Figure 9.6A shows that, for example, at 10 am the solar intensity was 780 w/m² on June 21, 2004 in Eugene, Oregon. If the solar intensity were constant at that value from, say, 9:30 am to 10:30 am, then the energy that would fall on a 1 meter² panel during that time would be 780 w-hr. This is the area of the rectangle encompassing 10 am in Figure 9.6A. The solar energy striking a 1 m² panel during the whole day is approximately the sum of the areas of the rectangles shown in Figure 9.6B.

- How many watt-hours of energy struck a 1 meter² panel at Eugene, Oregon on June 21, 2004?
- What is the value of that amount of energy at \$0.08 per kilowatt-hour?

Exercise 9.1.3 Shown in Figure 9.1.3 is a graph of the average daily solar intensity for Eugene, Oregon plotted as a function of day number, $1 \leq \text{day} \leq 365$. (The average is for the years 1990 - 2004, except for 2001 for which no data are posted.)

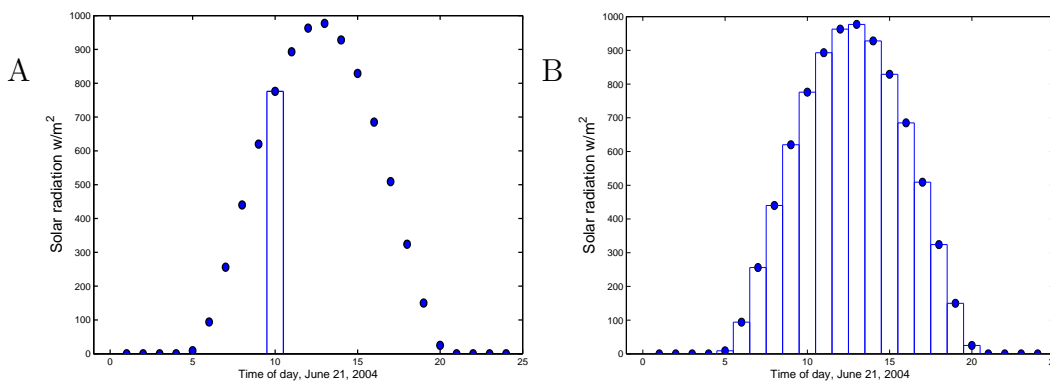
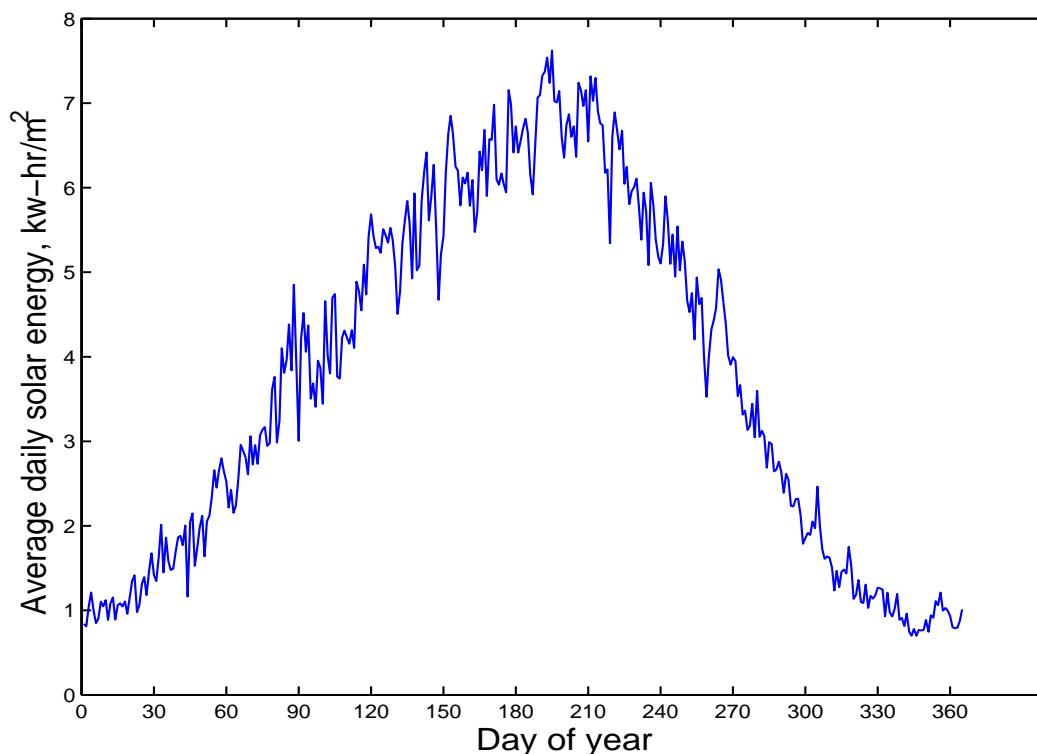

Figure 9.6: A graph of the solar intensity at Eugene, Oregon for June 21, 2004 (<http://solaradat.uoregon.edu>). The measure is global irradiance which is the total energy striking a horizontal plate measured in watts/meter².

- a. Was the sun intensity on June 21, 2004 above or below average for June 21 according to your answer to Exercise 9.1.2
- b. Use the graph in Figure 9.1.3 to compute in two different ways the total energy and the value of the total energy striking a one meter square panel for one year at Eugene, Oregon.
 1. Partition the year into 6 60-day intervals plus a single 5-day interval. Use as the solar intensity the average of the highest and lowest energies for that interval.
 2. Partition the year into 12 30-day intervals plus a single 5-day interval. Use as the solar intensity for each interval the average of the solar intensities at the first and last days of the interval.
- c. At \$0.08 per kw-hr, what is the value of the average solar energy that struck a one meter square panel for one year at Eugene, Oregon?

Figure for Exercise 9.1.3 A graph of the average solar intensity at Eugene, Oregon as a function of day of year.



Exercise 9.1.4 Dr. Frank Vignola of the University of Oregon forwarded the following practical problem. Pixels in satellite images are used to estimate solar irradiance values. The satellite images are taken at 15 minutes after the hour and the users need hourly values. How would one estimate hourly values from the data obtained at 15 minutes after the hour and how are the data degraded when the data are shifted?

Exercise 9.1.5 a. Using the data shown in Figure 9.1.3, let $E(t)$ be the cumulative energy striking a one meter-square panel from day one to day t . Compute $E(30)$, $E(60)$, $E(90)$, $E(120)$, $E(150)$, and $E(180)$.

b. Plot your data.

c. Estimate $E(135)$ and $E(140)$ from your data.

d. At (approximately) what rate is $E(t)$ increasing at time $t = 135$?

Exercise 9.1.6 a. Draw a horizontal line on Figure 9.1.3 so that the area of the rectangle bounded above by your horizontal line and below by the t -axis on the left by the vertical axis, $t = 0$ and on the right by the vertical line $t = 365$ is the same (approximately) as the area under the solar intensity curve (Figure 9.1.3).

b. Where does your line cross the vertical axis?

c. On what days does your line cross the curve?

d. What is the average daily solar intensity for the year?

Exercise 9.1.7 Compute the mass of ozone in the layer between 14 and 28 km above the 0.1 km square surrounding the Neumayer station for days 150 and 280. It may be easier to read the color graph at <http://www.awi-bremerhaven.de/MET/>, search for 'ozone 2004.'

At what time of year is there 'a hole in the ozone?'

Monte Carlo Integration. Although as noted we will not make serious use of Monte Carlo integration (throwing darts at pictures of leaves), you may find the next three exercises interesting and they may add to your understanding of ‘area’.

Exercise 9.1.8 Decide what will be meaning of the output of the program in Exercise Figure 9.1.8. (It is written for MATLAB, but very similar language is used for calculators and other computer programs).

Figure for Exercise 9.1.8 A MATLAB program. A collection of 100 points randomly distributed in a square with sides of length 1.

```
close all;clc
N=100;
count=0;
for i = 1:N
    x(i) = rand; y(i) = rand;
    if x(i)^2 + y(i)^2 < 1
        count = count+1;
    end
end
plot(x,y,'x','linewidth',2)
axis([0 1 0 1],'square')
set(gca,'xtick',[0 0.2 0.4 0.6 0.8 1.0])
set(gca,'ytick',[0 0.2 0.4 0.6 0.8 1.0])
4*count
```

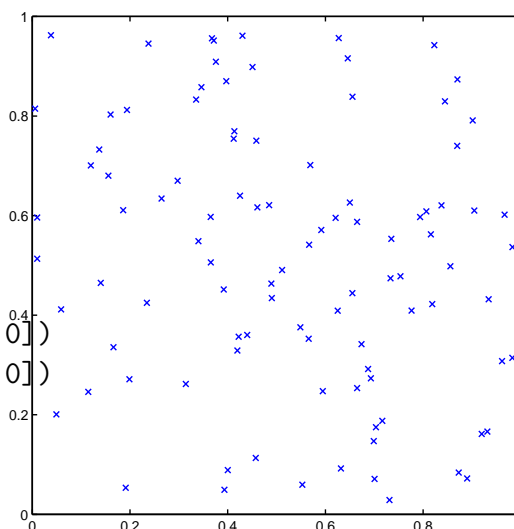

Exercise 9.1.9 Modify the previous program to estimate the area of the ellipse

$$\frac{x^2}{25} + \frac{y^2}{9} = 1$$

Exercise 9.1.10 Modify the previous program to estimate the area of the region bounded by the graphs of

$$y = \frac{1}{\sqrt{2\pi}} e^{-\frac{x^2}{2}}, \quad y = 0, \quad x = 0, \quad \text{and} \quad x = 1$$

Exercise 9.1.11 If an object moves at a constant speed, s m/min, over a time interval $[a, b]$ minutes, the distance, D , traveled is $D = s$ m/min $\times (b - a)$ min, $D = s \times (b - a)$ meters.

If the speed $s(t)$ varies over $[a, b]$, the distance, D , can be approximated by partitioning $[a, b]$ by $a = t_0 < t_1 < \dots < t_{n-1} < t_n = b$ into n subintervals so that $s(t)$ is approximately constant on each subinterval¹. Then D is the sum of the distances traveled during each subinterval and

$$D \doteq s(t_1) \times (t_1 - t_0) + s(t_2) \times (t_2 - t_1) + \dots + s(t_n) \times (t_n - t_{n-1}) \quad \text{meters.}$$

¹The symbol, \dots is called an ‘ellipsis’ and is explained in Appendix A

Approximate the distance traveled by a particle moving at the following speeds and over the indicated time intervals. Partition each time interval into 5 subintervals.

- a. $s(t) = t$ on $1 \leq t \leq 6$
- b. $s(t) = t^2$ on $0 \leq t \leq 2$
- c. $s(t) = 1/t$ on $1 \leq t \leq 3$
- d. $s(t) = \sqrt{t}$ on $2 \leq t \leq 7$

Exercise 9.1.12 Problem: What is the mass of a column of air above a one-meter square table top?

Imagine a one meter square vertical column, C , of air starting at sea level and extending upwards to 40,000 meters.

Shown in Figure 9.1.12 are ‘standard’ values of atmospheric density as a function of altitude up to 40,000 meters (U.S. Standard Atmospheres 1976, National Oceanic and Atmospheric Administration, NASA, U.S. Air Force, Washington, D.C. October 1976). The density is not constant throughout C , and the mass of C may be approximated by partitioning C into regions of ‘small’ volume, assuming that the density is constant within each region, and approximating the mass within each of the regions. Then the object will approximately have

$$\text{Mass} = \delta_1 \times v_1 + \delta_2 \times v_2 + \dots + \delta_n \times v_n$$

where $\delta_k \text{ Kg/m}^3$ and $v_k \text{ m}^3$ are respectively the density and volume in the k th region.

- a. Partition the altitude interval from 0 to 40,000 meters into at least 6 subintervals (they need not be all the same length). For each interval, find the volume of the region of C corresponding to the interval, find a density of the air within that region, and approximate the mass of the region. Approximate the mass in each region and add the results to approximate the mass of air in C .
- b. Does the size of your answer surprise you? Show that it is consistent with the standard pressure of one atmosphere being 760 mm of mercury? The density of mercury is $1.36 \times 10^4 \text{ Kg/m}^3$.

Figure for Exercise 9.1.12 Air density at various altitudes up to 40,000 meters. The horizontal segments are intended to assist in reading data from the graph.

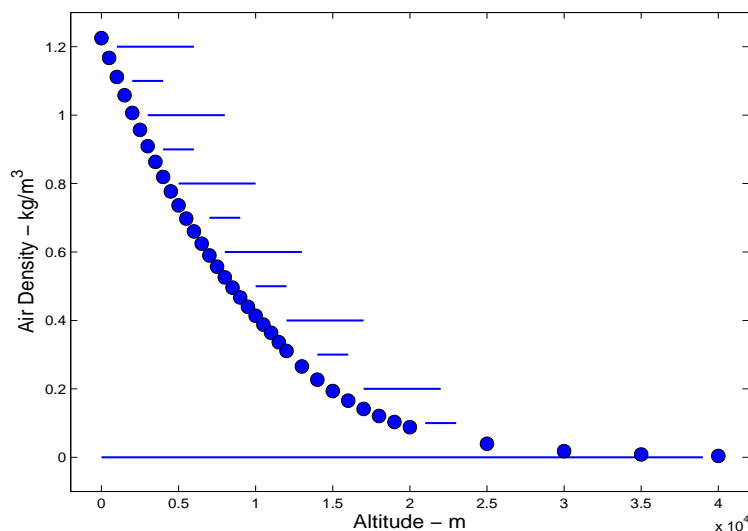

9.2 Areas Under Some Algebraic Curves

In This Section

Formulas are developed for the area of the region bounded by the t -axis, the graphs of $y = t^n$, $t = 0$, and $t = x$ for $n = 0, 1, 2$, and 3 . The result is that:

The area of the region bounded by the t -axis and the graph of $y = t^n$ between $t = 0$ and $t = x$ is

$$\frac{x^{n+1}}{n+1}$$

for $n = 1, 2, 3$, and 4 . The formula is actually valid for all values of n except $n = -1$.

$A = x^1 / 1$

$y = t^0$

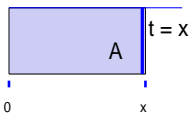

$A = x^2 / 2$

$y = t^1$

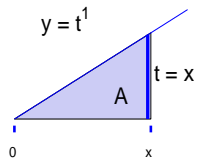

$A = x^3 / 3$

$y = t^2$

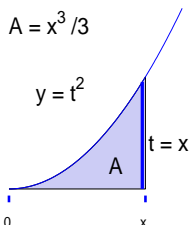

$A = x^4 / 4$

$y = t^3$

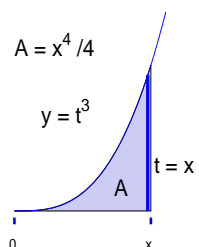

The work of this section requires some arithmetic formulas. Let n be a positive integer.

$$\underbrace{1 + 1 + 1 + \dots + 1}_{n \text{ terms}} = n \tag{9.2}$$

$$1 + 2 + 3 + \dots + n = \frac{n(n+1)}{2} \tag{9.3}$$

$$1^2 + 2^2 + 3^2 + \dots + n^2 = \frac{n(n+1)(2n+1)}{6} \tag{9.4}$$

$$1^3 + 2^3 + \dots + n^3 = \frac{n^2(n+1)^2}{4} \tag{9.5}$$

Explore 9.2.1 Do this.

- a. Run the following MATLAB program and interpret the results.

```
clear x
for i = 1:10; x(i)=i^2; end; x
sum(x)
```

- b. Alternate. Execute the following commands on your calculator and interpret the result.

```
seq(k^2,k,1,5)
```

```
sum seq(k^2,k,1,5)
```

and interpret the results. Note: **sum** and **seq** can be found in the menu

2nd LIST OPS

c. Check that $1^2 + 2^2 + 3^2 + \dots + n^2 = \frac{n(n+1)(2n+1)}{6}$ is valid for $n = 10$ and $n = 5000$.

d. Check that

$$1 + 2 + \dots + n = \frac{n \times (n + 1)}{2}$$

is valid for $n = 100$.²

■

Equations 9.2 - 9.5 and many similar equations are proved by the method of Mathematical Induction that is described in Appendix A.

Example 9.2.1 Problem. Find the area of the region **R** illustrated in Example Figure 9.2.1A that is bounded by the parabola $y = t^2$, the t -axis, and the line $t = x$ where x is a positive number.

Figure for Example 9.2.1.1 A. The region **R** bounded by the parabola $y = t^2$, the t -axis, and the line $t = x$. B. The same parabola with n rectangles with bases in $[0, x]$.

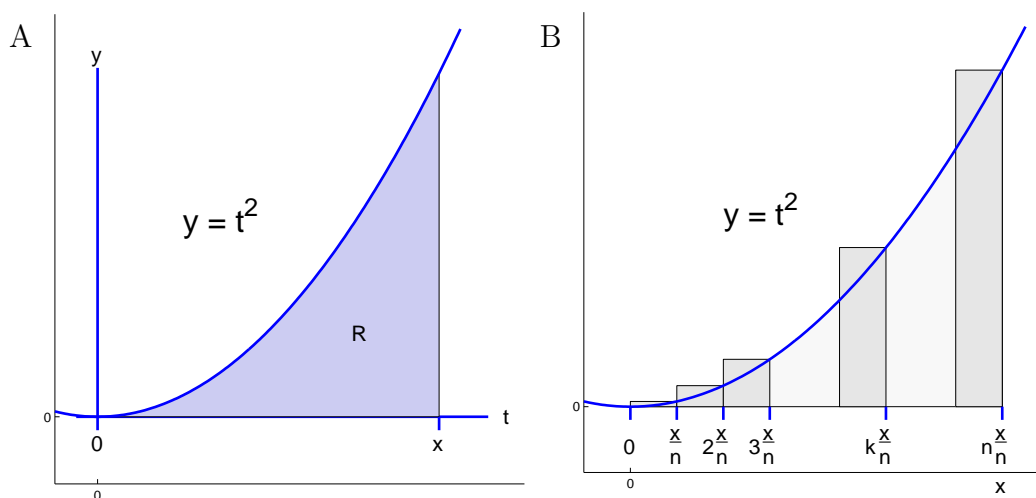

Solution. The sum of the areas of the rectangles in Figure 9.2.1.1B approximates the area of **R**. The interval $[0, x]$ on the horizontal axis has been partitioned into n subintervals by the numbers

$$0, \quad \frac{x}{n}, \quad 2\frac{x}{n} \quad \dots \quad (n - 1)\frac{x}{n}, \quad n\frac{x}{n}$$

The width of each rectangle in the figure is $\frac{x}{n}$. The height of each rectangle is the height of the parabola $y = t^2$ at the right end of the base of the rectangle. The heights of the rectangles, from left to right, are

$$\left(\frac{x}{n}\right)^2, \quad \left(2\frac{x}{n}\right)^2, \quad \dots \quad \left((n - 1)\frac{x}{n}\right)^2, \quad \left(n\frac{x}{n}\right)^2$$

²Carl F. Gauss's fourth grade teacher assigned his class the task of computing $1 + 2 + \dots + 99 + 100$ (probably to keep the little rascals busy for a while). Young Carl quickly responded, 5050, and explained that $1 + 2 + \dots + 99 + 100 = (1 + 100) + (2 + 99) + \dots + (50 + 51) = 50 \times 101 = 5050$. Note that $50 \times 101 = \frac{100 \times 101}{2}$. To his credit, the teacher promptly recognized genius, and brought Gauss to the attention of the local nobleman.

The sum, U_n , of the areas of the rectangles is

$$\begin{aligned}
 U_n &= \left(\frac{x}{n}\right)^2 \times \frac{x}{n} + \left(2\frac{x}{n}\right)^2 \times \frac{x}{n} + \cdots + \left((n-1)\frac{x}{n}\right)^2 \times \frac{x}{n} + \left(n\frac{x}{n}\right)^2 \times \frac{x}{n} \\
 &= (1^2 + 2^2 + \cdots + (n-1)^2 + n^2) \frac{x^3}{n^3} \\
 &= \frac{n(n+1)(2n+1)}{6} \frac{x^3}{n^3} \\
 &= \frac{2n^3 + 3n^2 + n}{6n^3} x^3 \\
 &= \left(\frac{1}{3} + \frac{1}{2n} + \frac{1}{6n^2}\right) x^3
 \end{aligned} \tag{9.6}$$

This is powerful medicine. The region R covered with $n = 50$ rectangles is illustrated in Figure 9.2.1.1C. The sum of the areas of the fifty rectangles, U_{50} , is close to the area of R , and

$$U_{50} = \left(\frac{1}{3} + \frac{1}{2 \times 50} + \frac{1}{6 \times 50^2}\right) x^3 = \left(\frac{1}{3} + 0.01 + 0.000067\right) x^3 \doteq \frac{1}{3} x^3$$

Furthermore,

$$\lim_{n \rightarrow \infty} U_n = \lim_{n \rightarrow \infty} \left(\frac{1}{3} + \frac{1}{2n} + \frac{1}{6n^2}\right) x^3 = \frac{x^3}{3}.$$

In Section 9.4 the area of R is defined to be this limit, so that:

For the region R bounded by the parabola $y = t^2$, the t -axis, and the line $t = x$,

$$\text{the area of } R \text{ is } \frac{x^3}{3}. \tag{9.7}$$

Figure for Example 9.2.1.1 (Continued) C. The parabola of A with 50 rectangles with bases in $[0,1]$.

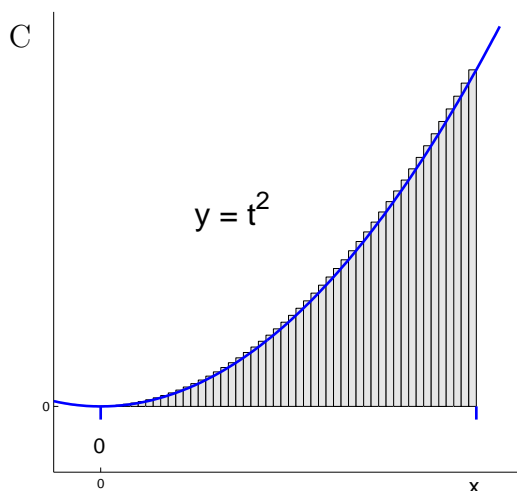

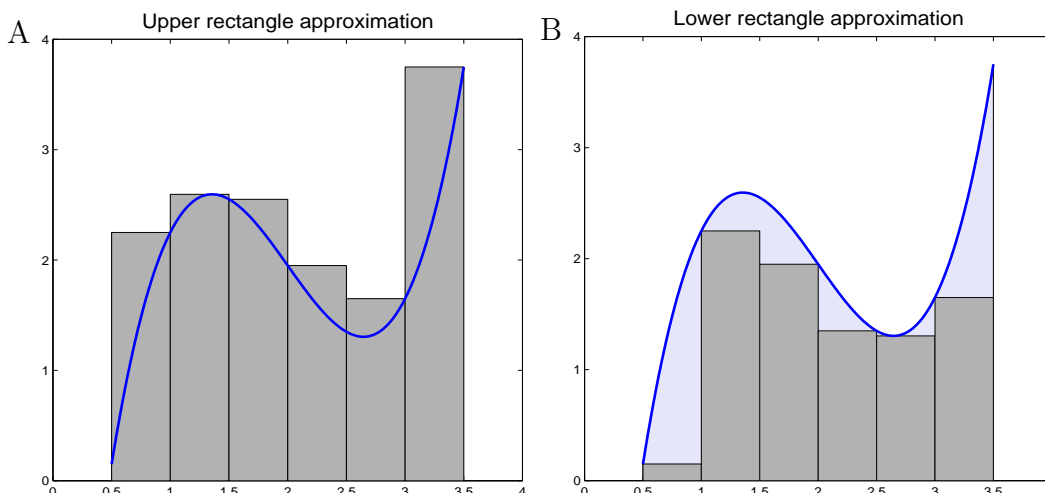

Figure 9.7: A. Upper rectangles approximating the area of a region bounded above by the graph of a function, f . B. Lower rectangles approximating the area of the same region.

Upper and lower rectangles. Note we freely use summation symbols such as

$$\sum_{k=1}^n k^2 \quad \text{and} \quad \sum_{k=0}^{n-1} \frac{1}{k+1}$$

Explanation of this notation is included in Appendix A.

In the Example 9.2.1 the top edges of the approximating rectangles were entirely on or above the graph of $y = t^2$ and are called *upper rectangles* and their sum, U_{50} , is an *upper approximation* to the area under consideration, as shown in Figure 9.7A. When the top edges of the rectangles lie entirely on or below the graph, the rectangles are called *lower rectangles* and their sum is called a *lower approximation*, as shown in Figure 9.7B. The area of the region lies between the upper and lower approximations.

Example 9.2.2 Problem. Find approximately the area of the region \mathbf{R} illustrated in Example Figure 9.2.2.2A bounded by the cubic $\mathbf{y} = \mathbf{x}^2(2 - \mathbf{x})$, and the \mathbf{X} -axis.

Figure for Example 9.2.2.2 A. The region \mathbf{R} bounded by the cubic $y = x^2(2 - x)$ and the \mathbf{X} -axis B. The same cubic with 10 rectangles with bases in $[0,2]$.

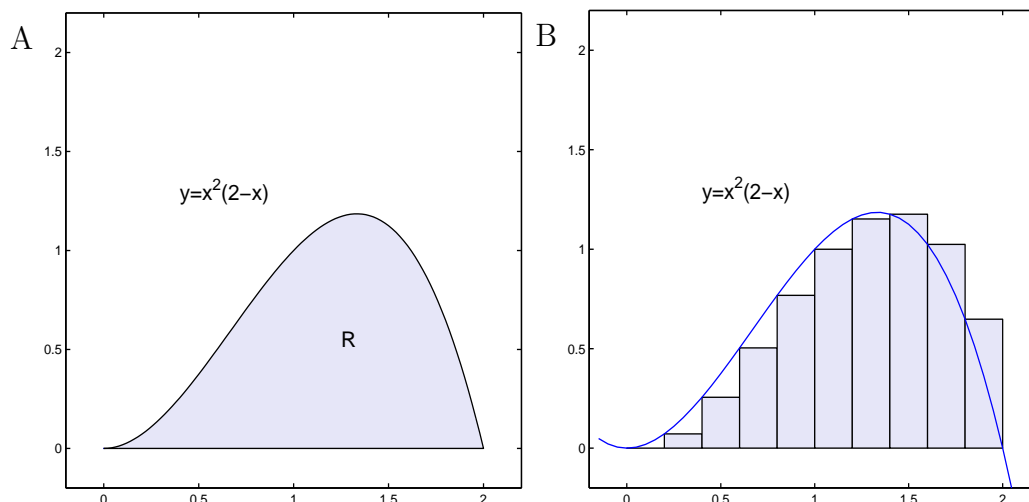

The cubic $y = x^2(2 - x) = 2x^2 - x^3$ intersects the x -axis at $x = 0$ and $x = 2$. The rectangles in Figure 9.2.2.2 partition $[0, 2]$ into ten intervals and the sum of the areas of the rectangles approximates the area of the region R . The rectangles are a mixture of lower and upper rectangles. The base of each rectangle is 0.2 and its height is the height of the *left* edge. For $k = 0$ to 9, the height of the $k + 1$ st rectangle, $[k \times 0.2, (k + 1) \times 0.2]$, is $2 \times (k \times 0.2)^2 - (k \times 0.2)^3$. The area of the $k + 1$ st rectangle is

$$\left[2 \times (k \times 0.2)^2 - (k \times 0.2)^3 \right] \times 0.2$$

The sum of the areas of the rectangles is

$$\begin{aligned} \sum_{k=0}^9 \left[2 \times (k \times 0.2)^2 - (k \times 0.2)^3 \right] \times 0.2 &= \\ \sum_{k=0}^9 \left[2(0.2)^2 \times k^3 - (0.2)^3 \times k^2 \right] \times 0.2 &= \\ 2(0.2)^3 \sum_{k=0}^9 k^3 - (0.2)^4 \sum_{k=0}^9 k^2 &= \\ 2(0.2)^3 \frac{9(9+1)(2 \times 9+1)}{6} - (0.2)^4 \frac{9^2(9+1)^2}{4} &= 1.32 \quad \blacksquare \end{aligned}$$

Exercises for Section 9.2, Areas Under Some Algebraic Curves.

Exercise 9.2.1 Use Mathematical Induction as shown in Appendix A to show the validity of Equation 9.3

$$1 + 2 + 3 + \cdots + n = \frac{n(n+1)}{2}.$$

Exercise 9.2.2 Show the validity of Equation 9.5

$$1^3 + 2^3 + 3^3 + \cdots + n^3 = \frac{n^2(n+1)^2}{4}.$$

Exercise 9.2.3 Find the generic terms for the following sums, and write the sums using Σ notation.

- $2^2 + 4^2 + 6^2 + 8^2 + 10^2$
- $\frac{1}{1.1} + \frac{1}{1.2} + \frac{1}{1.3} + \frac{1}{1.4} + \frac{1}{1.5} + \frac{1}{1.6} + \frac{1}{1.7} + \frac{1}{1.8} + \frac{1}{1.9} + \frac{1}{2}$
- $\left[\left(\frac{1}{1}\right)^2 + \left(\frac{1}{1.1}\right)^2 + \left(\frac{1}{1.2}\right)^2 + \cdots + \left(\frac{1}{1.8}\right)^2 + \left(\frac{1}{1.9}\right)^2 \right] \times \frac{1}{10}$
- $\left[(-1.0)^3 + (-0.9)^3 + (-0.8)^3 + \cdots + (-0.2)^3 + (-0.1)^3 \right] \times \frac{1}{10}$
- $\left[\sqrt{1 - 0.1^2} + \sqrt{1 - 0.2^2} + \sqrt{1 - 0.3^2} + \cdots + \sqrt{1 - 0.9^2} + \sqrt{1 - 1.0^2} \right] \times \frac{1}{10}$
- $\left[\sqrt{0.1} + \sqrt{0.2} + \sqrt{0.3} + \cdots + \sqrt{1.9} + \sqrt{2.0} \right] \times \frac{1}{10}$

Exercise 9.2.4 Give reasons for

a. $\sum_{k=1}^{n-1} k = \frac{n(n-1)}{2}$
 b. $\sum_{k=2}^n k^2 = \frac{n(n+1)(2n+1)}{6} - 1$

Exercise 9.2.5 Evaluate:

a. $\sum_{k=1}^{100} k$ b. $\sum_{k=3}^{100} k$ c. $\sum_{k=18}^{100} k$ d. $\sum_{k=1}^{100} 2k$
 e. $\sum_{k=1}^{10} k^2$ f. $\sum_{k=3}^{100} k^3$ g. $\sum_{k=1}^{100} (k+5)$ h. $\sum_{k=50}^{100} (3k+7)$
 i. $\sum_{k=1}^{10} 5k^2$ j. $\sum_{k=3}^{100} (k^3 - 9)$ k. $\sum_{k=32}^{78} (3k^2 - k)$ l. $(\sum_{k=50}^{100} 3k) + 7$

Exercise 9.2.6 See Exercise Figure 9.2.6. Show that the lower approximation to the area of the region bounded by the graph of $y = x^2$, the x -axis, and the line $x = 1$ based on 10 equal subintervals is:

a.

$$\sum_{k=0}^9 \left(\frac{k}{10}\right)^2 \times \frac{1}{10}$$

b.

$$= \frac{9 \times 10 \times 19}{6} \times \frac{1}{10^3}$$

c. The same as the upper sum minus the area of the tenth rectangle in the upper sum.

Figure for Exercise 9.2.6 Lower sum rectangles approximating the area of the region bounded by $y = x^2$, $y = 0$ and $x = 1$.

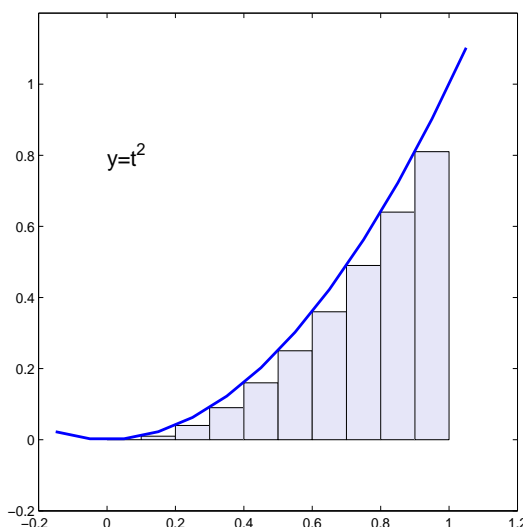

Exercise 9.2.7 a. Find a formula for the sum, L_n , of n lower rectangles approximating the area of the parabolic region, R , of Figure 9.2.1.1A.

b. Condense L_n into a single term as was done in Equations 9.6 for U_n .

- c. Evaluate L_{50} .
- d. Evaluate $\lim_{n \rightarrow \infty} L_n$.

Exercise 9.2.8 Let R be the region bounded by the graph of $y = t^3$, the t -axis, and the line $t = x$. See Figure 9.2.8

- a. Write a formula for an upper sum, U_n , of areas of n rectangles that approximates the area of R .
- b. Condense U_n into a single term as was done in Equations 9.6 for U_n of the parabolic region.
- c. Find $\lim_{n \rightarrow \infty} U_n$.

Figure for Exercise 9.2.8 The region bounded by $y = t^3$, the t -axis, and the line $t = x$ approximated by n rectangles.

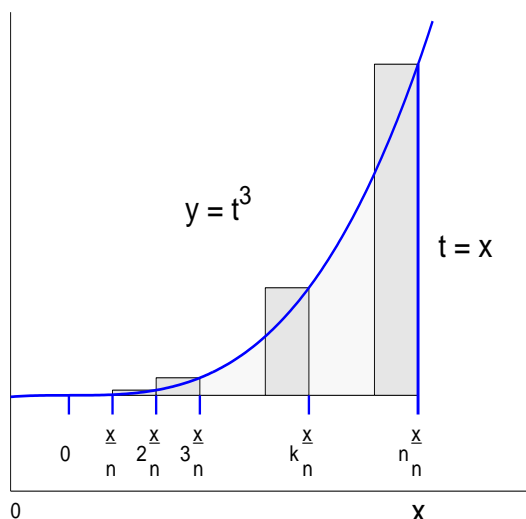

Exercise 9.2.9 Compute the area of the region bounded by the graph of $y = t^2$, the t -axis, and the lines $t = 1$ and $t = 2$. (Hint: Use Equation 9.7 and skip the rectangle bit.)

Exercise 9.2.10 Shown in Figure 9.2.10 is the first quadrant portion of the graph of $x^2 + y^2 = 1$.

- a. Use $x^2 + y^2 = 1$ to compute the height of the fourth rectangle from the left.
- b. Compute the area of the fourth rectangle from the left.
- c. Write (do not evaluate) an expression for, U_{10} , that is the sum of the areas of the ten rectangles.
- d. Write an expression for U_{100} that is the sum of the areas of 100 rectangles that approximates the area of the quarter circle.
- e. Use your computer or calculator to compute U_{100} and compare it with $\pi/4$.

Figure for Exercise 9.2.10 The first quarter portion of the circle $x^2 + y^2 = 1$ and 10 rectangles.

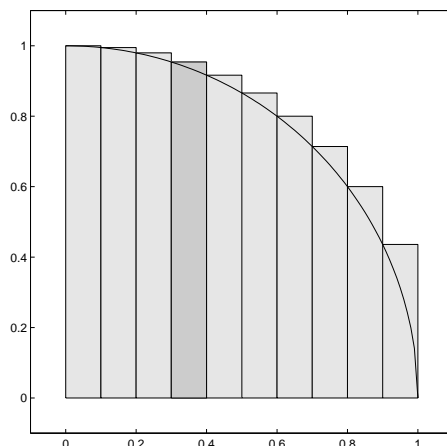

Exercise 9.2.11 Use ordinary geometry to

- Show that the area of the shaded region in Figure 9.2.11A is x .
- Show that the area of the shaded region in Figure 9.2.11B is $\frac{x^2}{2}$.

Figure for Exercise 9.2.11 A. Graphs of $y = 1$ and $t = x$. B. Graphs of $y = t$ and $t = x$.

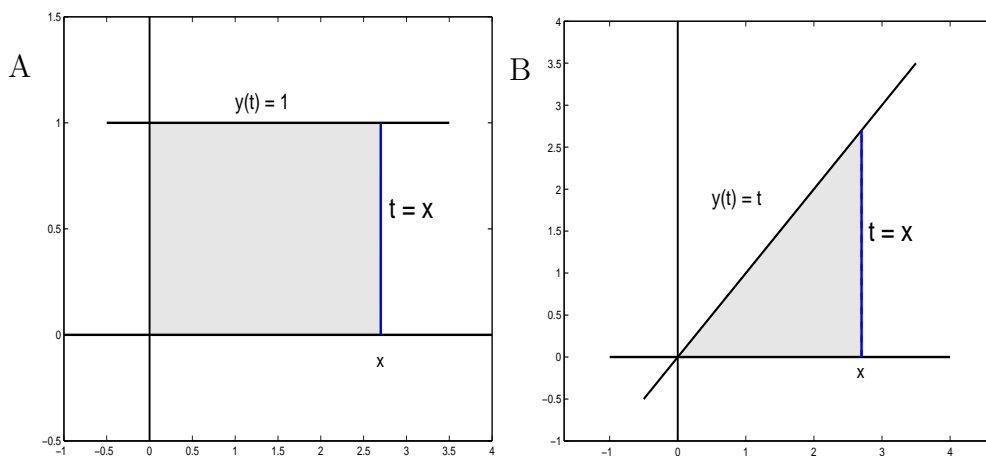

Exercise 9.2.12 A consequence of some previous problems is:

If n is either 0, 1, 2, or 3, x is a positive number, and A is the area of the region bounded by the graphs of

$$y = t^n \quad y = 0 \quad t = 0 \quad \text{and} \quad t = x,$$

then

$$\begin{aligned} \text{Case : } n = 0 \quad A = x & & \text{Case : } n = 1 \quad A = \frac{x^2}{2} \\ \text{Case : } n = 2 \quad A = \frac{x^3}{3} & & \text{Case : } n = 3 \quad A = \frac{x^4}{4} \end{aligned} \tag{9.8}$$

Make a guess as to the values of A for $n = 4$, $n = 10$, and $n = 1,568$.

Exercise 9.2.13 Summary Exercise: For additional practice on the preceding procedures, the following formula is presented.

$$\sum_{k=1}^n k^4 = \frac{n(n+1)(2n+1)(3n^2+3n-1)}{30}$$

Use the formula to find the area of the region bounded by the graphs of

$$y = t^4 \quad y = 0 \quad t = 0 \quad \text{and} \quad t = x.$$

- a. Suppose n is a positive integer. Partition $[0, x]$ into n nonoverlapping intervals with end points

$$0 \quad \frac{x}{n} \quad 2\frac{x}{n} \quad \dots \quad (k-1)\frac{x}{n} \quad k\frac{x}{n} \quad \dots \quad n\frac{x}{n}$$

- b. What is the area of a rectangle based on the k th interval and having base interval, $((k-1)\frac{x}{n}, k\frac{x}{n})$ and height $[k\frac{x}{n}]^4$?
- c. Show that the sum, U_n , of the areas of all such rectangles is

$$U_n = x^5 \times \left(\frac{1}{5} + \frac{1}{2n} + \frac{1}{3n^2} - \frac{1}{30n^4} \right)$$

- d. Show that

$$\lim_{n \rightarrow \infty} U_n = \frac{x^5}{5}$$

9.3 A general procedure for computing areas.

We generalize from the previous problems and define a procedure for computing the area of a region, R , bounded above by the graph of a function, f , below by the horizontal axis, on the left by a line $t = a$ and on the right by a line $t = b$. The function, f , should be defined and positive for all t in $[a, b]$. We will assume f is increasing on $[a, b]$. Bounds on the errors of our estimates will be obtained.

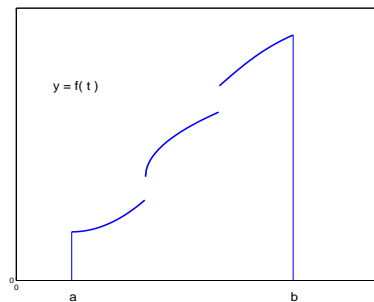

Assume f is a positive *increasing* function defined on an interval $[a, b]$. We describe a procedure to compute the area of the region between the graph of f and the X -axis as illustrated in Figure 9.8A. The function f may have one or more discontinuities. The region should be considered as the union of the vertical segments reaching from the horizontal axis to a point on the graph of f .

We can approximate the area of the region R as follows:

- Choose a number, n , of rectangles to be used.
- Let $h = \frac{b-a}{n}$.

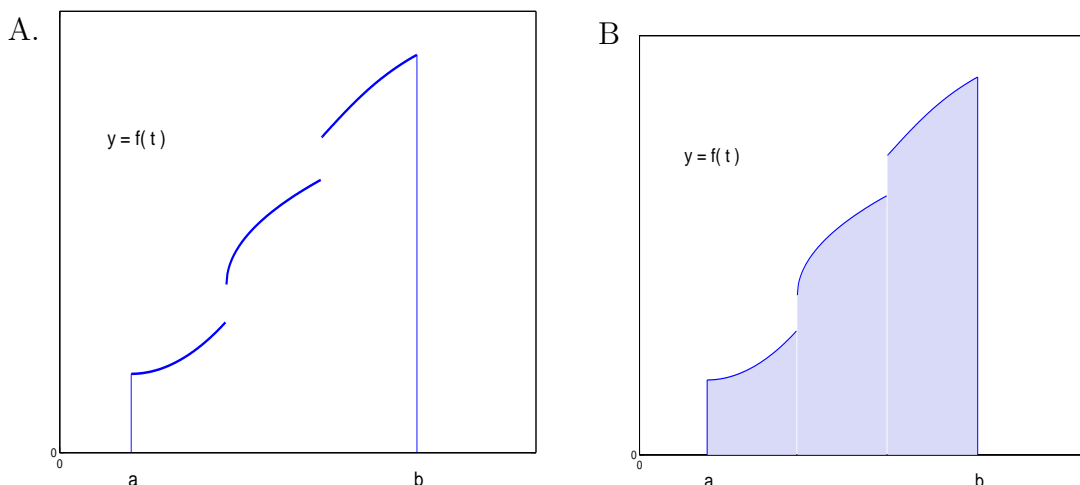

Figure 9.8: A. A region bounded above by the graph of an increasing function. B. Shaded region showing relation to discontinuities.

- Partition the interval $[a, b]$ into n equal subintervals using points $a = t_0 < t_1 < t_2 < \dots < t_{n-1}, t_n = b$. Because the intervals are of equal length, the length of each will be $\frac{b-a}{n} = h$ and

$$t_0 = a \quad t_1 = a + h \quad t_2 = a + 2 \times h \quad \dots \quad t_k = a + (k) \times h \quad \dots \quad t_n = a + n \times h$$

- For $k = 1, \dots, n$, let A_k be the area of the rectangle $t_{k-1} \leq t \leq t_k, 0 \leq y \leq f(t_k)$. The rectangles are illustrated in Figure 9.9A and are referred to as *upper* rectangles.
- Let $U_n = \sum_{k=1}^n A_k$. The union of the upper rectangles contains the region R so that U_n is greater than or equal to the area of R.
- For $k = 1, \dots, n$, let B_k be the area of the rectangle $t_{k-1} \leq t \leq t_k, 0 \leq y \leq f(t_{k-1})$. The rectangles are illustrated in Figure 9.9B and are referred to as *lower* rectangles.
- Let $L_n = \sum_{k=1}^n B_k$. The region R contains the union of the lower rectangles so that L_n is less than or equal to the area of R.

For *increasing functions*

$$L_n = \sum_{k=1}^n f(t_{k-1}) \times (t_k - t_{k-1}) \quad \text{and} \quad U_n = \sum_{k=1}^n f(t_k) \times (t_k - t_{k-1})$$

Shown in Figure 9.10 are both lower and upper rectangles approximating the area of the region R. The differences, $A_k - B_k$, between the areas of the upper and lower rectangles are the areas of the small rectangles at the top of the larger rectangles. Copies of the small rectangles, translated horizontally, are shown in an “Error Box” to the right in Figure 9.10, and all are above an interval of width $\frac{b-a}{n}$. The height of the Error Box is vertical span of f , $f(b) - f(a)$ and the

$$\text{The Area of the Error Box is} \quad [f(b) - f(a)] \times \frac{b-a}{n}$$

Because

$$U_n - L_n = \sum_{k=1}^n A_k - \sum_{k=1}^n B_k = \sum_{k=1}^n A_k - B_k$$

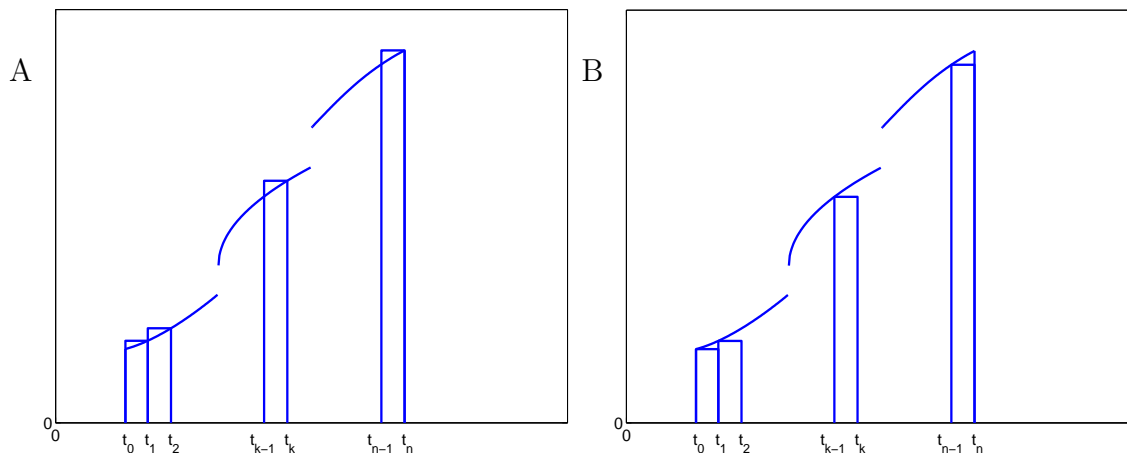

Figure 9.9: A. Upper rectangles for a region bounded above by the graph of a function. B. Lower rectangles for a region bounded above by the graph of an increasing function.

it follows that $U_n - L_n$ is the area of the Error Box, or

$$U_n - L_n = [f(b) - f(a)] \times \frac{b - a}{n} \tag{9.9}$$

Equation 9.9 is important. Because

$$L_n \leq \text{The Exact Area of the Region } R \leq U_n$$

the *approximation error* in using either L_n or U_n as an approximation to the Area of R is no bigger than $U_n - L_n$. By choosing n large enough,

$$U_n - L_n = (f(b) - f(a)) \times \frac{b - a}{n}$$

can be made as small as one wishes and thus the error in using either U_n or L_n as an approximation to the Area of R can be made as small as one wishes.

Example 9.3.1 The previous information may be used in two ways, as illustrated in the following example.

1. First, one may have computed the upper approximating sum to the area of the region bounded by the graphs of $y = \sqrt{t}$, $y = 0$, and $t = 4$ using 20 subintervals, as shown in Figure 9.3.1.1. The upper sum is $5.51557\dots$. The error box for this computation is shown to the right of the region. Because each rectangle is of width $\frac{4}{20} = 0.2$, the error box is of width 0.2. The height of the error box is $\sqrt{4} - \sqrt{0} = 2$ so the error in the approximation, $5.51557\dots$ is no larger than $2 * 0.2 = 0.4$.
2. On the other hand, one may wish to compute the area of the region in Figure 9.3.1.1 correct to 0.01, and need to know how many intervals are required to insure that accuracy. For any number, n , of intervals,

The error box is of height $\sqrt{4} - \sqrt{0} = 2$ and width $\frac{4 - 0}{n}$

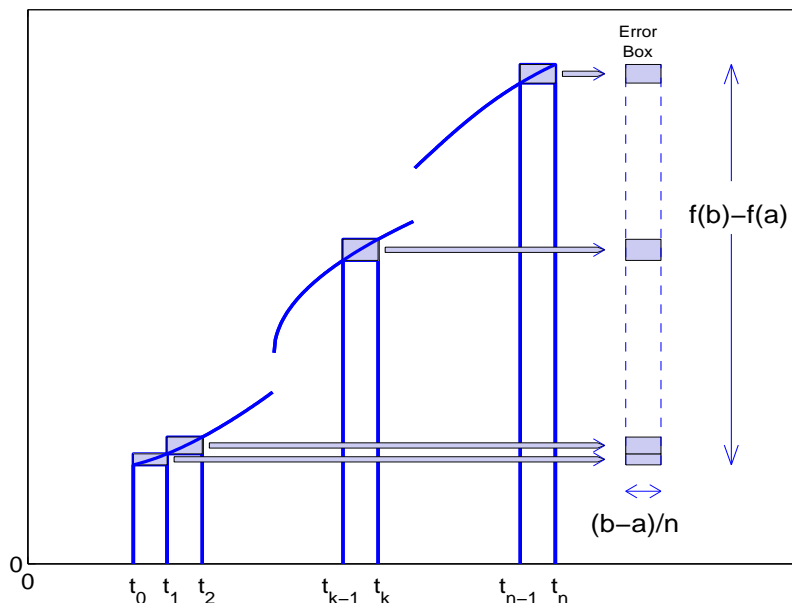

Figure 9.10: Upper and lower rectangles for a region bounded above by the graph of an increasing function.

Thus,

$$\text{The size of the error box is } 2 \times \frac{4 - 0}{n} = \frac{8}{n}$$

Because the error is sure to be less than the size of the error box, our desired accuracy will be obtained if the size of the error box is less than 0.01. Therefore we require $\frac{8}{n} < 0.01$ so that $\frac{8}{0.01} < n$, or $n = 800$. We will find that the actual error is only approximately one-half the size of the error box, and that $n = 400$ will almost give the required accuracy. ■

Figure for Example 9.3.1.1 The graph of $y = \sqrt{x}$ on $[0, 4]$ with 20 upper rectangles.

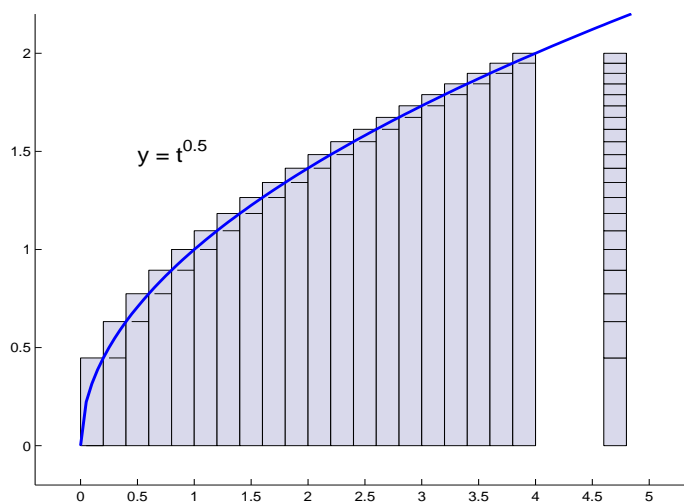

9.3.1 Trapezoidal approximation.

The average,

$$T_n = \frac{U_n + L_n}{2}$$

often gives a very good approximation to the Area of R , and for increasing functions its error is less than $\frac{1}{2} \times (f(b) - f(a)) \times (b - a)$ (one half the error of U_n or L_n). For an evenly spaced partition of $[a, b]$,

$$t_k - t_{k-1} = \frac{b - a}{n} = h$$

and

$$U_n = \sum_{k=1}^n f(t_k) \times h \quad \text{and} \quad L_n = \sum_{k=1}^n f(t_{k-1}) \times h$$

and

$$\begin{aligned} T_n = \frac{U_n + L_n}{2} &= \frac{1}{2} \left(\sum_{k=1}^n f(t_k) \times h + \sum_{k=1}^n f(t_{k-1}) \times h \right) \\ &= \left(\frac{f(a)}{2} + \sum_{k=1}^{n-1} f(t_k) + \frac{f(b)}{2} \right) \times h \end{aligned} \tag{9.10}$$

For the twenty intervals in Figure 9.3.1.1,

$$U_{20} = 5.51557, \quad L_{20} = 5.11557, \quad \text{and} \quad T_{20} = 5.31557.$$

The actual area is 5.33333 so that the error in T_{20} is 0.018, considerably less than the error bound for U_{20} of 0.4 computed in Example 9.3.1 and the actual error in U_{20} of 0.18.

The word trapezoid is used for T_n because the average of the areas of the upper and lower rectangles

$$\frac{f(t_k)(t_k - t_{k-1}) + f(t_{k-1})(t_k - t_{k-1})}{2} = \frac{f(t_k) + f(t_{k-1})}{2}(t_k - t_{k-1})$$

is the area of the trapezoid, shaded in Figure 9.11, bounded on the left by the line from $(t_{k-1}, 0)$ to $(t_{k-1}, f(t_{k-1}))$ and on the right by $(t_k, 0)$ to $(t_k, f(t_k))$.

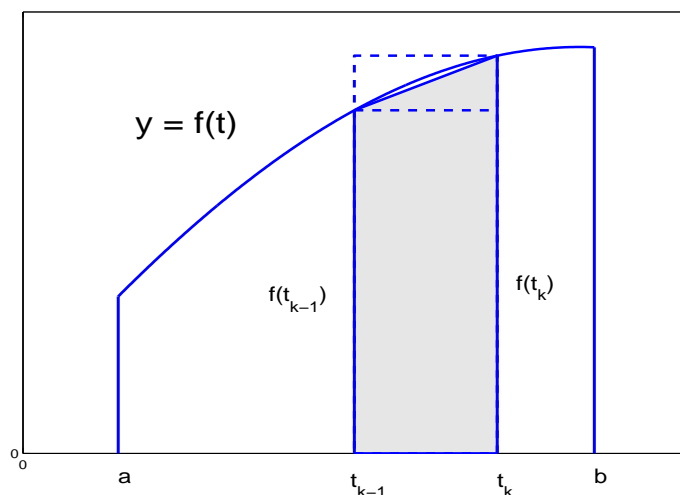

Figure 9.11: An increasing function. The average of the areas of the upper and lower rectangle is the area of the trapezoid.

Example 9.3.2 Work done in compressing air. Movement a distance d (meters) against a constant force F Newtons³ requires an amount $W = F \times d$ Newton-meters of work. If the force is not constant, the interval of motion $[a, b]$ may be partitioned by

$$a = x_0 < x_1 < x_2 < \cdots < x_{n-1} < x_n = b.$$

If the force on interval $[x_{k-1}, x_k]$ is approximately F_k , then the work done is approximately

$$W \doteq \sum_{k=1}^n F_k \times (x_k - x_{k-1}).$$

A 60 cc syringe was attached to a pressure gauge as shown in Figure 9.12. The plunger of area 5.5 cm^2 was extracted to 60 cc and the air inside the cylinder was at standard atmospheric pressure of $P_0 = 760 \text{ mm mercury} = 10.13 \text{ Newton/cm}^2$. The plunger was pushed inward at 5 cc increments (to the 55 cc mark, to 50 cc, \cdots to 20 cc and to 15 cc) and the pressure was recorded at each step (table in Figure 9.12). The distance between 5 cc marks on the syringe was 0.9 cm.

Problem. How much work was done?

Solution. The force against the plunger on the k th step was

$$F_k \doteq (P_k - P_0) \text{ N/cm}^2 \times 5.5 \text{ cm}^2.$$

The total work done, W , was approximately

$$\begin{aligned} W &\doteq \sum_{k=1}^9 (P_k - P_0) \text{ N/cm}^2 \times 5.5 \text{ cm}^2 \times (x_k - x_{k-1}) \text{ cm} \\ &= \sum_{k=1}^9 (P_k - P_0) \times 5.5 \times 0.9 \text{ N-cm} \end{aligned} \quad (9.11)$$

Using the data from Figure 9.12 we calculate

$$W \doteq 383 \text{ N-cm} = 3.83 \text{ N-m}$$

The number $5.5 \text{ cm}^2 \times 0.9 \text{ cm}$ is, except for measurement error, equal to $4.95 \doteq 5 \text{ cm}^3$, or the 5 ml marked on the syringe and in the data. Therefore the work done is

$$W \doteq \sum_{k=1}^9 (P_k - P_0) \times (V_{k-1} - V_k) = - \sum_{k=1}^9 (P_k - P_0) \times (V_k - V_{k-1}) \text{ N-cm} \quad (9.12)$$

Continued in Exercise 9.3.13. One Newton-meter (called a Joule) is equal to 1 watt-sec. a flashlight with a 1.5 amp bulb and two 1.5 volt batteries uses 4.5 watts. The 3.83 N-m would burn the flashlight for $3.83/4.5 = 0.85$ seconds. At \$0.08 per kilowatt-hour, the value of the 3.83 N-m is \$0.000000022. ■

Exercises for Section 9.3, A general procedure for computing areas.

Exercise 9.3.1 a. Identify two rectangles in Figure 9.10 whose areas are $[f(t_1) - f(t_0)] \times h$.

³N is the symbol for one Newton, the force required to accelerate 1 kilogram 1 meter per second per second.

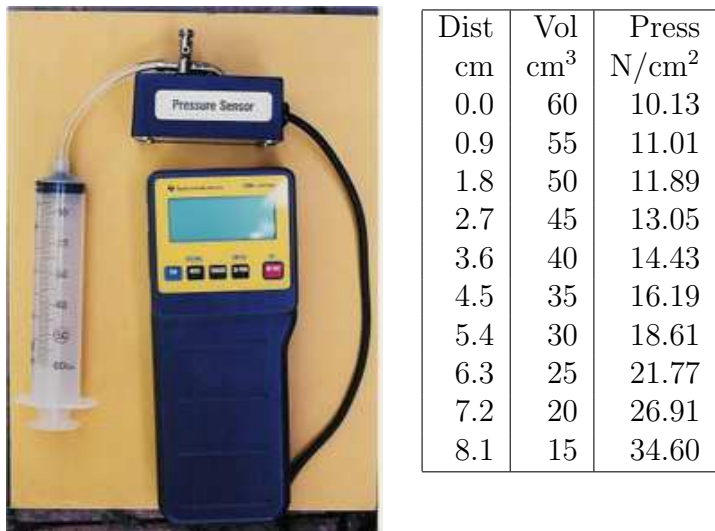

Figure 9.12: Syringe with attached pressure gauge and CBL manufactured by Vernier, Inc. Data from compressing the air in the syringe.

- b. Identify two rectangles in Figure 9.10 whose areas are $[f(t_2) - f(t_1)] \times h$.
- c. Identify two rectangles in Figure 9.10 whose areas are $[f(t_k) - f(t_{k-1})] \times h$.
- d. Identify one rectangle whose area is $[f(b) - f(a)] \times h$.

Exercise 9.3.2 Suppose one is to compute the area of the region bounded by the graphs of

$$y = \frac{4}{1 + t^2} \quad y = 0 \quad t = 0 \quad t = 1$$

The graph of $y = \frac{4}{1 + t^2}$ is shown in exercise Figure 9.3.2. The graph is decreasing instead of increasing, but with modest changes the Error Box computation still applies. The upper rectangles have the heights associated with the left ends of the intervals, and the lower rectangles have heights associated with the right ends of the intervals.

Figure for Exercise 9.3.2 The graph of $y = 1/(1 + t^2)$.

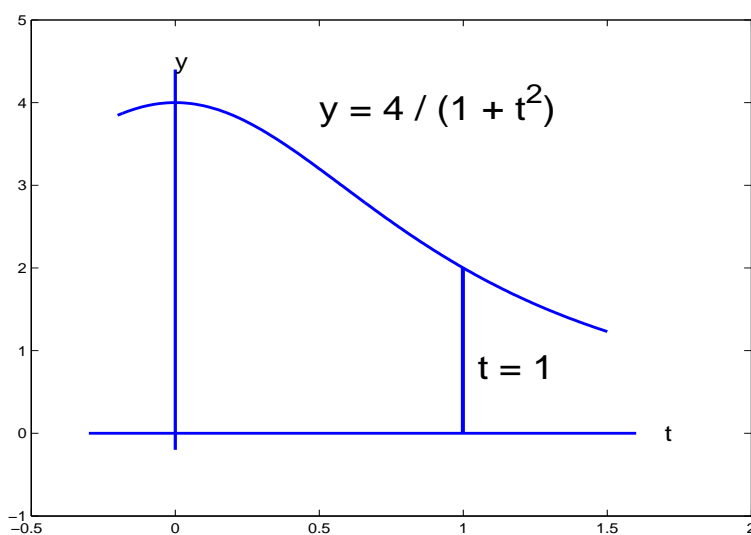

Copy the picture to your paper and on your copy:

- Shade the region bounded by the graphs of $y = \frac{4}{1+t^2}$, $y = 0$, $t = 0$ and $t = 1$.
- Draw the upper rectangles based on $n = 5$ intervals.
- The upper sum based on $n = 5$ intervals is

$$\left[\frac{4}{1+(0/5)^2} + \frac{4}{1+(1/5)^2} + \frac{4}{1+(2/5)^2} + \frac{4}{1+(3/5)^2} + \frac{4}{1+(4/5)^2} \right] \times \frac{1}{5} = 3.334926$$

Draw the lower sum rectangles based on $n = 5$ intervals and compute the lower sum.

- Draw the Error Box for the difference between the upper and lower sums based on $n = 5$ intervals. What is the area of the Error Box
- Argue that for any n , $U_n - L_n \leq 2/n$.
- What value of n should be chosen to insure that $U_n - L_n \leq 0.004$
- Compute the upper and lower sums for $n = 500$. It was not terribly exciting to compute the lower sum for $n = 5$, and the computation for $n = 500$ may be a drag. Therefore, to compute the upper sum, run the following MATLAB program.

```
close all;clc;clear
for k = 0:499
    F(k+1)=( 4/(1+(k/500)^2) )/500;
end
U = sum(F)
L = U - 4/500 + 2/500
A = ( U + L )/2
```

Alternate. Enter the following strokes on your calculator:

```
sum seq(4/(1+(K/500)^2)*(1/500) ,K,0,499,1)      ENTER
```

Remember: **sum** and **seq** can be found in the menu

```
2nd LIST      OPS
```

Your answer should be 3.143591987. Now press 2nd ENTER and modify the strokes to compute the lower sum.

- What is your best estimate of the area based on L_{500} and U_{500} .
- The actual area of the region in question is $\pi = 3.141592654 \dots$. Check that $L_{500} \leq \pi \leq U_{500}$ and that $U_{500} - L_{500} = 0.004$.

Exercise 9.3.3 Define a region that has area computed by

$$\sum_{k=0}^{499} \frac{4}{1 + ((k + 0.5)/500)^2} \frac{1}{500}.$$

Exercise 9.3.4 Modify the MATLAB program or calculator steps shown in Exercise 9.3.2 and compute the sum of:

- Forty rectangles to approximate the area of the region bounded by $y = t^2$, $y = 0$, $t = 2$, and $t = 4$.
- Forty rectangles to approximate the area of the region bounded by $y = t^2$, $y = 0$, $t = 1$, and $t = 5$.
- Forty rectangles to approximate the area of the region bounded by $y = t^3$, $y = 0$, $t = 1$, and $t = 5$.
- Forty rectangles to approximate the area of the region bounded by $y = t^{-1}$, $y = 0$, $t = 1$, and $t = 5$.

Exercise 9.3.5 Consider the region, R , bounded by the graphs of

$$y = 1/t \quad y = 0 \quad t = 1 \quad t = 2$$

See Exercise Figure 9.3.5. Into how many intervals of equal size must $[1,2]$ be partitioned in order that the lower approximating rectangles will approximate the area of R correct to 3 decimal places (Error less than 0.0005).

Compute that sum on your computer or calculator. (See methods in Exercise 9.3.2.) It is a curious fact that the exact answer is $\ln 2$.

Figure for Exercise 9.3.5 The graph of $y = 1/t$.

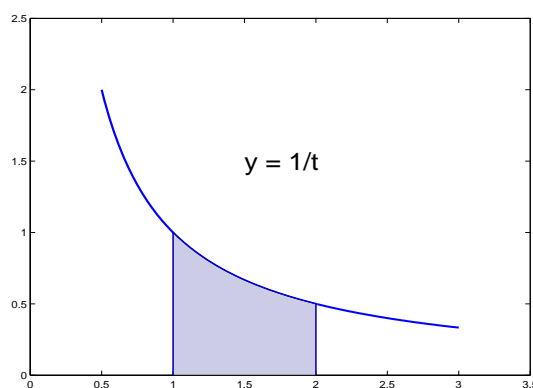

Exercise 9.3.6 Find a lower sum approximating the area bounded by the graphs of $y = \sqrt{1 - t^2}$, $y = 0$, and $t = 0$ correct to 3 decimal places (error < 0.0005). What is the exact area?

Exercise 9.3.7 Compute the sum of the areas of 10 trapezoids based on the partition $[0, 0.1, 0.2, \dots, 1]$ of $[0,1]$ used to approximate the area of the region bounded by the graphs of

$$y = \frac{4}{1 + t^2} \quad y = 0 \quad t = 0 \quad t = 1$$

Show that this sum more closely approximates the exact area than does the sum of 500 lower rectangles. The exact area is π .

Note: Be clever. Either use the average of upper and lower sums based on 10 intervals which have been previously computed, or use Equation 9.10.

Figure for Exercise 9.3.7 Graph of $y = 4/(1 + x^2)$, $0 \leq x \leq 1$ for Exercise 9.3.7

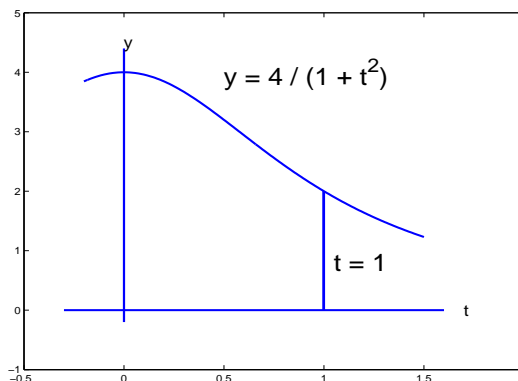

Exercise 9.3.8 In Problem 9.3.5 you found that 1000 equal intervals are necessary in order that the rectangular sums approximating the area of the region bounded by the graphs of

$$y = 1/t \quad y = 0 \quad t = 1 \quad t = 2$$

approximate the area of the region correct to three digits (error less than 0.005). The area of the region correct to six digits is $\ln 2 \doteq 0.693147$. Approximate the area of the region using 20 trapezoids based on equal subintervals of $[1, 2]$ and show that the accuracy of the approximation is better than that of the rectangular approximation using 1000 intervals.

Exercise 9.3.9 The exact area of the region bounded by the graphs of

$$y = \sqrt{t} \quad y = 0 \quad \text{and} \quad t = 5$$

is $\frac{2}{3}5^{3/2} \doteq 7.453560$. Compute the upper rectangular approximation and the trapezoidal approximation to the area based on 50 subintervals and compute their relative accuracies.

Exercise 9.3.10 Compute the area of the region bounded by the graphs of $y = \sin x$ and $y = 0$ for $0 \leq x \leq \pi$ using eight intervals and the trapezoid rule and the same eight intervals with upper rectangles. The exact answer is 2. Compute the errors and relative errors for each rule.

Exercise 9.3.11 Cardiac Stroke Volume. The chart in Figure 9.13 shows the timing of events in the cardiac cycle

- Find a graph from which you can compute the ‘Aortic blood flow (ventricular outflow)’ measured in Liters/min.
- The stroke volume may also be defined as the difference in the volume of blood in the ventricle at the end of diastole and the volume of blood in the ventricle at the end of systole. Find the curve ‘Ventricular Volume’, compute stroke volume from it, and compare with your previous computation.
- Assume that one cardiac cycle takes about 0.8 seconds so that the heart is beating at $60/0.8 = 75$ beats per minute.

Multiply the stroke volume for a single beat by 75 and compare with the conventional 5 - 6 Liters/minute for a resting adult.

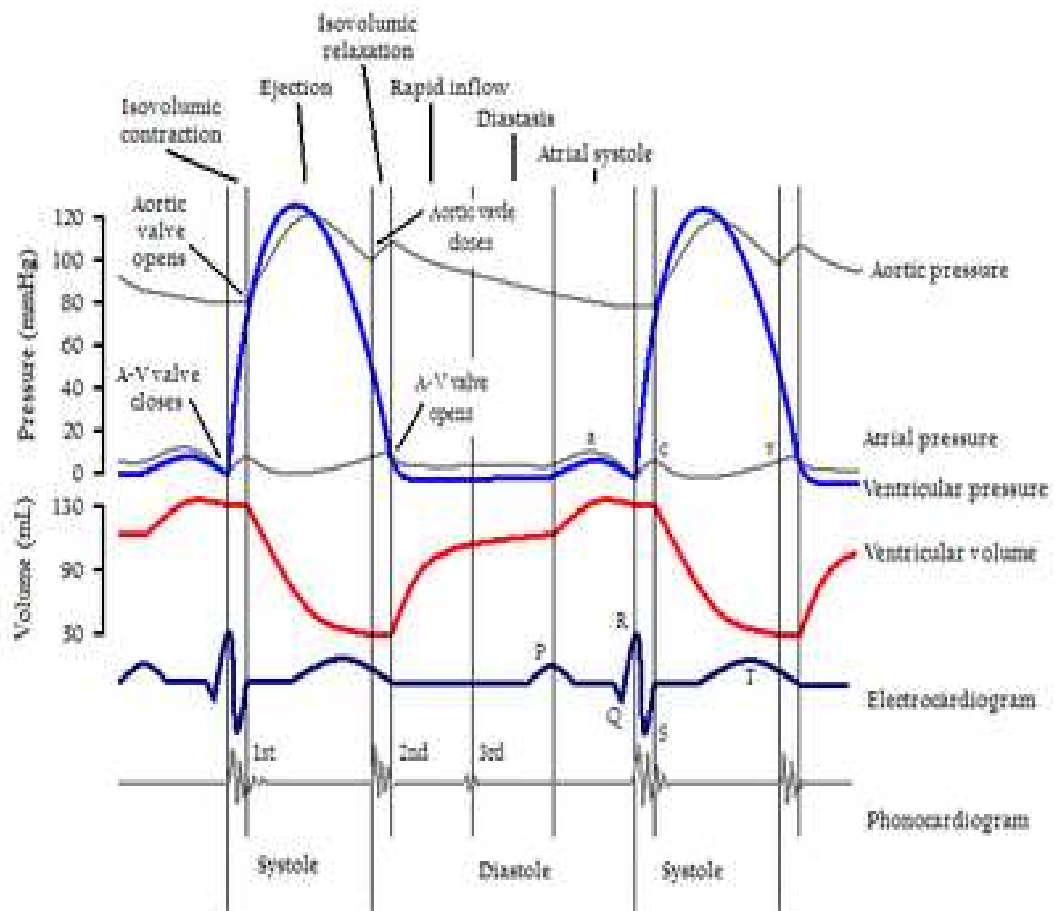

Figure 9.13: A Wikipedia graph is shown: created by Agateller (Anthony Atkielski), converted to svg by atom. <http://en.wikipedia.org/wiki/Electrocardiography> Assume that the time from beginning of systole to the end of diastole is 0.8 seconds.

Exercise 9.3.12 External Cardiac Work. This problem is directed to measuring the work done by the heart referred to as external work.

If liquid is pumped through a tube at a constant flow rate, R cm³/sec and at a constant pressure, P Newtons/cm², during a time interval, $[a, b]$ measured in seconds, then the work done, W , is

$$W = R \times P \times (b - a) \quad \text{Newton-cm.}$$

- Confirm that the units on $R \times P \times (b - a)$ are Newton-cm, units of work.
- Suppose the flow rate or pressure is not constant. Suppose R and P are continuous functions and the flow rate is $R(t)$ and the pressure is $P(t)$ for $a \leq t \leq b$. Let

$$a = t_0 < t_1 < t_2 < \cdots < t_n = b$$

be a partition of $[a, b]$. Write an approximation to the work, W , of pumping the liquid at the flow rate $R(t)$ and pressure $P(t)$ during $[a, b]$ based on the partition.

- The graph shown does not show Aortic blood flow. It does show, however, Ventricular volume which decreases during Systole. Use Ventricular volume to compute Aortic blood flow in ml/sec at 7 different points during Systole.
- Using the same 7 points and read Ventricular pressure during Systole, and approximate the work done by a single stroke of the heart.

A much larger amount of work is done by the heart as ‘Internal Work’ that ‘includes transporting ions across membranes, internal mechanical events \cdots , overcoming internal viscosity, and rearranging the muscular architecture as the heart contracts⁴’. Heart efficiency is defined as the ratio of External Work to the sum of External and Internal Work and ranges from 5 to 10 percent.

Exercise 9.3.13 Continuation of Example 9.3.2, Work done in compressing air.

- Plot Pressure *vs* Volume for the data of Figure 9.12 and draw a smooth curve through the data points. Recall Equation 9.12. Interpret the work done, Equation 9.11, in terms of an area of that graph. Should the work done be positive?
- It should be apparent from your graph and Equation 9.11 that we have computed (383 N-cm) an upper sum for the area. Compute a lower sum. **Remember** that for an increasing graph the lower sum is the upper sum minus the area of the error box. This is a decreasing graph. Try the same thing in this case.
- Compute the average of the upper sum and lower sum. This is the trapezoidal approximation to the work done.
- In 1662, Robert Boyle spread a rumor that $PV = \text{constant}$. But there is a 15% variation in PV shown in Table 9.2 and only 3.3% variation in $P \cdot (V + 3.6)$. Should we advise Boyle of his error, or examine our equipment?

Exercise 9.3.14 A tank has 30 m³ capacity and has 15 m³ of water in it. Water flows into it at the rate of $R(t) = 1 + t^2$ m³/min for $0 \leq t \leq 3$ minutes. Does the tank overflow?

⁴Rhoades and Tanner, p 274

Table 9.2: PV and $P \cdot (V + 3.6)$ for the data in Figure 9.12.

PV	608	606	595	587	577	567	558	544	538	519
$P(V + 3.6)$	644	645	637	634	629	625	625	623	635	643

Exercise 9.3.15 Records of Mississippi River discharge rates measured at McGregor, Iowa for April 16 - 22, 1994 are shown in the Exercise Table 9.3.15. Obtained from http://co.water.usgs.gov/sediment/stnHeader.cfm?station_id=05389500 Note from the records that the flow increased and the sediment increased during that week, and it is reasonable to assume that there was a warm spell the led to snow melting or a rain in the drainage basin.

- Approximate the total flow for the Mississippi for the week April 16 -22, 1994.
- Approximate the total suspended sediment that flowed past McGregor, Iowa in the Mississippi River for the week of April 16-24, 1994.
- The drainage basin is about 67,500 mi². How many tons per square mile were removed from the drainage basin during that week?

Table for Exercise 9.3.15 Mississippi River Discharge, April 16-22, 1994.

Day	Discharge m ³ /sec	Sediment mg/liter
Apr 16	1810	20
Apr 17	1870	25
Apr 18	1950	30
Apr 19	2000	33
Apr 20	2030	36
Apr 21	2140	40
Apr 22	2200	41

Exercise 9.3.16 Work against the force of gravity. Suppose a 3 kilogram mass instrument is lifted 20,000 kilometers above the surface of the Earth, the force acting on it is not constant throughout the motion. See Figure 9.14. The acceleration of gravity may be computed for a distance x above the Earth as

$$\text{Acceleration of gravity at altitude } x = 9.8 \times \frac{R^2}{(R + x)^2} \quad (9.13)$$

where $R \doteq 6,370$ kilometers is the radius of the Earth. We partition the interval $[0, 20,000]$ into 4 equal subintervals and assume the acceleration of gravity to be constant on each of the subintervals.

We introduce a new procedure: Choose the value of the acceleration of gravity for each subinterval to be the value at the **midpoint** of the interval. Thus the midpoint of the first interval, $[0, 5000]$ is 2500 and the gravity constant for the first 5000 kilometers of motion will be

$$9.8 \times \frac{6370^2}{(6370 + 2500)^2} = 5.05$$

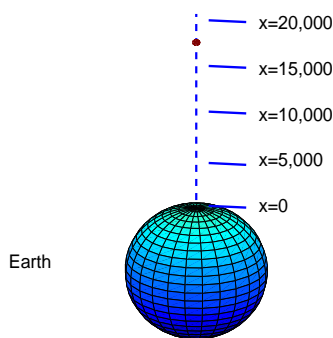

Figure 9.14: Earth and a 3 kg object lifted 20,000 km above the surface.

The work to lift the instrument the first 5000 kilometers is approximately

$$5.05 \times 3 \times 5000 = 75814 \quad \text{Newton-meters}$$

- Approximate the total work to lift the instrument to 20,000 km.
- Approximate the total work done to lift the 3 kg instrument 40,000 km. (You already know the work required to lift it 20,000 km.)
- Approximate the total work done to lift the 3 kg instrument 100,000 km.

It is a very interesting question as to whether the instrument can ‘escape from the Earth’s gravity field’ with a finite amount of work. We will return to the question in Section 11.5.1, Escape Velocity.

9.4 The Integral

We have used upper and lower rectangles to approximate areas between the graphs of functions and the horizontal axis. Other rectangular sums often give better estimates, but in most cases rectangular sums give acceptable estimates. In addition to areas, the approximating sums approximate other important physical and biological quantities, generally representing the accumulation of some quantity that is occurring at a variable rate. Implicit in all of the examples is that better approximations will be computed when the total interval is partitioned into smaller intervals. The total accumulation is called the *integral* of a function f on an interval $[a, b]$. A short definition of the integral is

Definition 9.4.1 The integral of a function, I. Suppose f is a function defined on an interval $[a, b]$. The integral of f from a to b is

$$\lim_{n \rightarrow \infty} \sum_{k=1}^n \left[f \left(a + k \times \frac{b-a}{n} \right) \times \frac{b-a}{n} \right] \tag{9.14}$$

if the limit exists. The notation for the integral is

$$\int_a^b f \quad \text{or as in most calculus books} \quad \int_a^b f(t) dt$$

The function, f , is called the **integrand**, and

$$\sum_{k=1}^n \left[f \left(a + k \times \frac{b-a}{n} \right) \times \frac{b-a}{n} \right]$$

is called an **approximating sum** for the integral.

Definition 9.4.1 is a formalization of the computations of the previous sections. The $\lim_{n \rightarrow \infty}$ provides for the better approximations with smaller intervals in the partitions. The numbers

$$\left\{ a + k \times \frac{b-a}{n} \right\}_{k=0}^n = \left\{ a, a + \frac{b-a}{n}, a + \frac{b-a}{n}, \dots, a + k \frac{b-a}{n}, \dots, a + n \frac{b-a}{n} = b \right\}$$

partition $[a, b]$ into n equal subintervals of length $\frac{b-a}{n}$. $f(a + k \times \frac{b-a}{n})$ evaluates f at the right endpoint of the k th interval.

$$\sum_{k=1}^n f \left(a + k \times \frac{b-a}{n} \right) \times \frac{b-a}{n}$$

sums the value of f at the right endpoint times the length of the interval. After discussion of notation, we will apply Definition 9.4.1 to relatively more difficult functions than we have considered so far.

Concerning the notations, $\int_a^b f$ and $\int_a^b f(t) dt$.

The dt in $\int_a^b f(t) dt$ is often a mystery to students, for good reason. The two notations for an integral in Definition 9.4.1 can be compared as follows.

For $f(t) = t^2$ $1 \leq t \leq 3$, one may write

$$\int_1^3 f \quad \text{or one may write} \quad \int_1^3 t^2 dt \quad .$$

In a sense, $\int_1^3 t^2 dt$ allows one to define the integrand $f(t) = t^2$ and write the integral, all with one symbol. However, $\int_1^3 t^2$ would do that as well, so what is the dt ?

One could try to avoid the central problem by discussing

$$\int_0^3 e^{kt^2} dt$$

and say that dt specifies that t is the independent variable (and not k). In fact,

dt is read ‘with respect to t .’

The symbol $\int_a^b f(t) dt$ is read, 'the integral from a to b of f of t with respect to t .' Furthermore, if you use a calculator or computer calculus package to compute $\int_0^3 e^{kt^2} dt$ you have to specify that the integration is with respect to t (and not with respect to k). For example, with 100 stored in K on a TI-86, the command `fnInt(K*x^2,x,0,1)` returns 33.33. `fnInt(K*x^2,K,0,1)` returns 4.9348 which is a bit of a mystery until you learn that π has been stored in x . The 'respect to,' (dt), is stored in the second position of `fnInt`.

We will also find that dt is useful for keeping track of symbols in a change of variable in the integrand, and in doing so, dt is sometimes called a 'differential.'

But there is a very colorful and controversial history of the symbol dt . We discuss it in the context of area. According to some, dt is an *infinitesimal* length on the t -axis, $f(t) dt$ is an infinitesimal area under the graph of f , and $\int_a^b f(t) dt$ sums the infinitesimal areas under the graph of f from a to b to give the total area under the graph of f between a and b . We will not attempt an elaboration. Many people use such intuitive language to quickly move from a physical problem to an integral that computes the solution to the physical problem. For example, if $P(v)$ is the pressure in a syringe when the volume is v , then $P(v) dv$ is the 'infinitesimal work' done when the plunger is moved and 'infinitesimal distance', dx , and the volume changes by an 'infinitesimal volume', dv , and the total work done in moving from $v = 60$ to $v = 20$ is $\int_{60}^{20} P(v) dv$.

If the concept of an infinitesimal seems vague and questionable, you have good company. After Newton had described calculus in *Principia*, a noted philosopher, Bishop Berkeley, objected strenuously to the concept of dt , writing, "What are these fluxions? The velocities of evanescent increments. And what are these same evanescent increments? They are neither finite quantities nor quantities infinitely small, nor yet nothing. May we not call them ghosts of departed quantities?"⁵

In order to clear up some of the ambiguities, Augustin Cauchy in 1823 introduced the definition of integral we show in Definition 9.4.4.

Units of dimension. Because

$$\int_a^b f(t) dt = \lim_{n \rightarrow \infty} \sum_{k=1}^n \left[f \left(a + k \times \frac{b-a}{n} \right) \times \frac{b-a}{n} \right]$$

the integral $\int_a^b f(t) dt$ 'inherits' the dimension of the approximating sum $\sum_{k=1}^n \left[f \left(a + k \times \frac{b-a}{n} \right) \times \frac{b-a}{n} \right]$. The notation $\int_a^b f(t) dt$ helps keep track of the units of dimension on the integral. If, for example, $f(t)$ is the velocity of a particle, the factor $(b-a)/n$ in the approximating sum will have units of time, $f(a + k \times \frac{b-a}{n}) \times (b-a)/n$ will have units of distance, and the approximating sum and the integral will have units of distance. In $\int_a^b f(t) dt$, $f(t)$ has units of velocity, dt can be considered to have units of time so that $f(t) dt$ has units of distance and $\int_a^b f(t) dt$ has units of distance.

Example 9.4.1 The answers to examples and exercises of sections 9.1 through 9.3 all may be expressed in terms of integrals:

1. The area of the region bounded by the graphs of $y = f(t) \geq 0$, $y = 0$, $t = a$ and $t = b$ is $\int_a^b f(t) dt$.
2. The mass of a body of density $D(x)$ and cross sectional area $A(x)$ along an interval $[a, b]$ is $\int_a^b D(x) \times A(x) dx$.

⁵A good source of this debate is in Philip J. Davis and Reuben Hersh, *The Mathematical Experience*, Houghton Mifflin Co., Boston, 1982.

3. The work done by the heart during one heart beat is $\int_b^e R(t) \times P(t) dt$ where R is aortic flow rate and P is pressure in the left ventricle. The units on this integral are

$$R(t) \frac{\text{ml}}{\text{sec}} \times 1 \frac{\text{cm}^3}{\text{ml}} \times P(t) \frac{\text{N}}{\text{cm}^2} \times dt \text{ sec} = \text{N-cm}$$

which is a unit of work. Had the units not been of work, we would think that the integral is incorrectly formulated.

4. Atmospheric density at altitude h meters is approximately $1.225e^{-0.000101h}$ kg/m^3 for $0 \leq a \leq 5000$. The mass of air in a one square meter vertical column between 1000 and 4000 meters is $\int_{1000}^{4000} 1.225e^{-0.000101h} \times 1 dh$. ■

Example 9.4.2 We use Definition 9.4.1 to compute the area of the region R bounded by $y = x^2(2 - x) = 2x^2 - x^3$, $y = 0$, $x = 0$, and $x = 2$. The region for which we wish to compute the area is shown in Figure 9.4.2.2 and the area is

$$\int_0^2 2x^2 - x^3 dx$$

Figure for Example 9.4.2.2 The region R bounded by $y = x^2(2 - x)$ and $y = 0$.

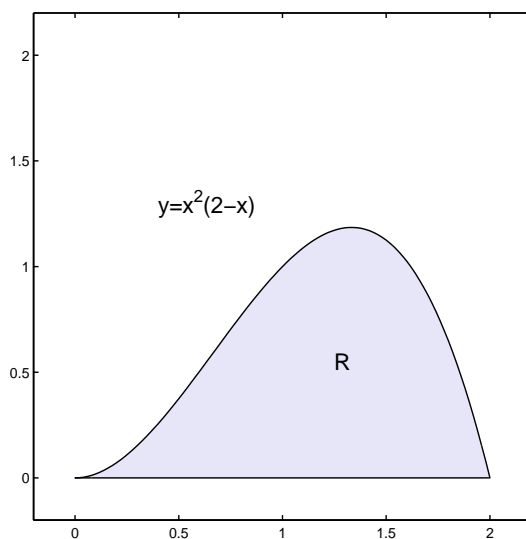

Following Equation 9.14, partition $[0, 2]$ into n subintervals $0, 2/n, 2(2/n), 3(2/n) \cdots n(2/n) = 2$ each of length $2/n$. Then write the sum

$$\begin{aligned} \int_0^2 2x^2 - x^3 dx &= \lim_{n \rightarrow \infty} \sum_{k=1}^n \left(2 \left(k(2/n) \right)^2 - \left(k(2/n) \right)^3 \right) \times 2/n \\ &= 2 \lim_{n \rightarrow \infty} \left(\sum_{k=1}^n k^2 \right) \frac{2^3}{n^3} - \lim_{n \rightarrow \infty} \left(\sum_{k=1}^n k^3 \right) \frac{2^4}{n^4} \\ &= 2 \lim_{n \rightarrow \infty} \frac{n(n+1)(2n+1)}{6} \frac{2^3}{n^3} - \lim_{n \rightarrow \infty} \frac{n^2(n+1)^2}{4} \frac{2^4}{n^4} \\ &= 2 \lim_{n \rightarrow \infty} 2^3 \left(\frac{1}{3} + \frac{1}{2n} + \frac{1}{6n^2} \right) - \lim_{n \rightarrow \infty} 2^4 \left(\frac{1}{4} + \frac{1}{2n} + \frac{1}{4n^2} \right) \\ &= 2 \times \frac{2^3}{3} - \frac{2^4}{4} = \frac{4}{3} \end{aligned}$$

The area of R is $4/3$. We computed an approximation of 1.32 to this area in Example 9.2.2. ■

Example 9.4.3 We use Definition 9.4.1 to compute the area of the region bounded by $y = e^t$, $y = 0$, $t = 0$, and $t = x$. The region for which we wish to compute the area is shown in Figure 9.4.3.3 and we wish to compute

$$\int_0^x e^t dt.$$

Equation 9.14 evaluates the integrand at the right end of each interval, and for this particular problem it is slightly simpler to evaluate the integrand at the left end points and compute

$$\lim_{n \rightarrow \infty} \left[\sum_{k=1}^n f \left(a + (k-1) \times \frac{b-a}{n} \right) \right] \times \frac{b-a}{n}$$

The effect is to change from an upper approximation to a lower approximation.

Figure for Example 9.4.3.3 The region bounded by $y = e^t$, $y = 0$, $t = 0$ and $t = x$.

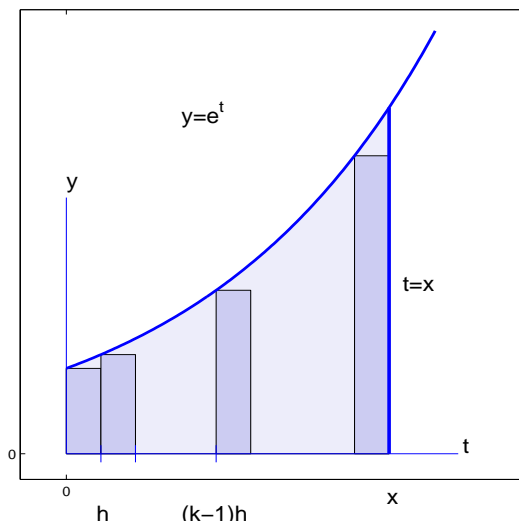

We recall a formula for the sum of a geometric series:

$$1 + a + a^2 + a^3 + \dots + a^{n-1} = \frac{a^n - 1}{a - 1} \tag{9.15}$$

This formula can be confirmed by multiplication of

$$(1 - a) \times (1 + a + a^2 + a^3 + \dots + a^{n-1})$$

Assume the interval $[0, x]$ to be partitioned into n equal subintervals, each of length x/n and we let $h = x/n$. The k th such interval has endpoints on the t axis at $(k-1) \times h$ and $k \times h$. The area of the k th rectangle is

$$e^{(k-1) \times (x/n)} \times \frac{x}{n} = e^{(k-1) \times h} \times h,$$

and the sum of the areas of the n rectangles is

$$\sum_{k=1}^n e^{(k-1) \times h} \times h$$

Our job is to make sense of

$$\sum_{k=1}^n e^{(k-1) \times h} \times h \quad \text{because} \quad \int_0^x e^t dt = \lim_{n \rightarrow \infty} \sum_{k=1}^n e^{(k-1) \times h} \times h.$$

Observe that

$$e^{(k-1) \times h} \times h = (e^h)^{k-1} \times h$$

so that

$$\sum_{k=1}^n e^{(k-1) \times h} \times h = \left[\sum_{k=1}^n (e^h)^{k-1} \right] \times h.$$

We write the part in []'s in long format with a generic term as

$$\begin{array}{ccccccc} k = 1 & & k = 2 & & & & k = n \\ (e^h)^0 & + & (e^h)^1 & + & \cdots & + & (e^h)^{k-1} & + & \cdots & + & (e^h)^{n-1} \end{array}$$

With $a = e^h$ the preceding sum is the geometric series shown in Equation 9.15 and we conclude that

$$\begin{aligned} \sum_{k=1}^n (e^h)^{k-1} \times h &= \frac{(e^h)^n - 1}{e^h - 1} \times h \\ &= \left((e^{x/n})^n - 1 \right) \frac{h}{e^h - 1} \\ &= (e^x - 1) \times \frac{1}{\frac{e^h - 1}{h}} \end{aligned}$$

Now the problem is to evaluate

$$\int_0^x e^t dt = \lim_{n \rightarrow \infty} \sum_{k=1}^n e^{(k-1) \times (h)} \times h = \lim_{n \rightarrow \infty} (e^x - 1) \times \frac{1}{\frac{e^h - 1}{h}} = (e^x - 1) \times \frac{1}{\lim_{h \rightarrow 0} \frac{e^h - 1}{h}}$$

By its definition, Definition 5.2.1 on page 219, the number e has the property that

$$\lim_{h \rightarrow 0} \frac{e^h - 1}{h} = 1.$$

We conclude that

$$\int_0^x e^t dt = e^x - 1 \quad \blacksquare$$

Example 9.4.4 Use the trigonometric identity **Bolt out of the Blue!**⁶

$$\sum_{k=1}^n \sin k\theta = \frac{-\cos(n\theta + \frac{\theta}{2}) + \cos \frac{\theta}{2}}{2 \sin \frac{\theta}{2}} \quad \text{and} \quad \lim_{h \rightarrow 0} \frac{\sin(h)}{h} = 1$$

⁶**The Blue:** Use $2 \sin x \sin y = -\cos(x + y) + \cos(x - y)$. Let $S = \sum_{k=1}^n \sin k\theta$. Then

$$\begin{aligned} 2S \sin \frac{\theta}{2} &= 2 \sum_{k=1}^n \sin k\theta \sin \frac{\theta}{2} = \sum_{k=1}^n (-\cos(k\theta + \theta/2) + \cos(k\theta - \theta/2)) \\ &= (-\cos(\theta + \theta/2) + \cos(\theta - \theta/2)) + (-\cos(2\theta + \theta/2) + \cos(2\theta - \theta/2)) + \cdots + (-\cos(n\theta + \theta/2) + \cos(n\theta - \theta/2)) \\ &= (-\cos(3\theta/2) + \cos(\theta/2)) + (-\cos(5\theta/2) + \cos(3\theta/2)) + \cdots + (-\cos(n\theta + \theta/2) + \cos(n\theta - \theta/2)) \\ &= -\cos(n\theta + \theta/2) + \cos(\theta/2) \end{aligned}$$

to compute $\int_0^x \sin t \, dt$, for $0 \leq x \leq \pi$. The integral is the area of a segment, R , of the sine curve shown in Figure 9.4.4.4.

Figure for Example 9.4.4.4 The region, R , bounded by $y = \sin t$ and $y = 0$ between $t = 0$ and $t = x$, and a typical k th rectangle.

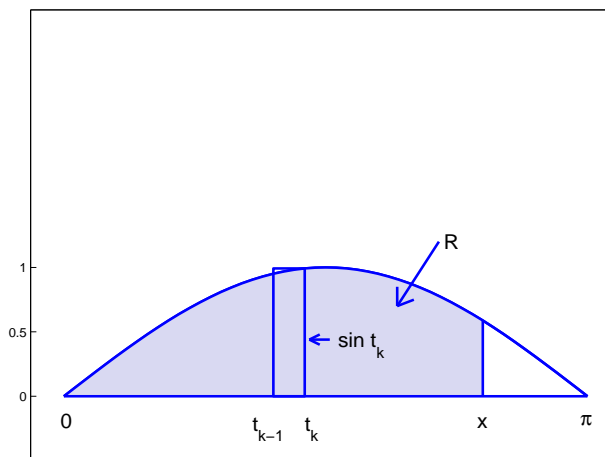

Partition the interval $[0, x]$ into n equal subintervals by $t_k = k \times x/n$. Then

$$\begin{aligned}
 \int_0^x \sin t \, dt &= \lim_{n \rightarrow \infty} \sum_{k=1}^n (\sin t_k) \times (t_k - t_{k-1}) \\
 &= \lim_{n \rightarrow \infty} \sum_{k=1}^n \left(\sin \left(k \times \frac{x}{n} \right) \right) \times \frac{x}{n} \\
 &= \lim_{n \rightarrow \infty} \frac{-\cos \left(n \times \frac{x}{n} + \frac{x}{2n} \right) + \cos \left(\frac{x}{2n} \right)}{2 \sin \frac{x}{2n}} \times \frac{x}{n} \\
 &= \lim_{n \rightarrow \infty} \left(-\cos \left(x + \frac{x}{2n} \right) + \cos \left(\frac{x}{2n} \right) \right) \frac{\frac{x}{2n}}{\sin \frac{x}{2n}} \\
 &= \left(\lim_{n \rightarrow \infty} \left(-\cos \left(x + \frac{x}{2n} \right) \right) + \lim_{n \rightarrow \infty} \cos \left(\frac{x}{2n} \right) \right) \lim_{n \rightarrow \infty} \frac{\frac{x}{2n}}{\sin \frac{x}{2n}} \\
 &= (-\cos x + \cos 0) \times 1 = 1 - \cos x
 \end{aligned}$$

Specifically,

$$\int_0^{\pi/2} \sin t \, dt = 1 - \cos \frac{\pi}{2} = 1, \quad \text{and} \quad \int_0^{\pi} \sin t \, dt = 1 - \cos \pi = 2. \quad \blacksquare$$

9.4.1 A more flexible definition of integral.

The sum in Definition of Integral I 9.4.1 uses intervals of equal length and evaluates f at the right end point of each interval. In order to provide some flexibility in computation of approximating sums (upper, lower or any of the others) and variable interval sizes, the following definitions are used.

Definition 9.4.2 Partition of an interval. Suppose $[a, b]$ is an interval. A partition of $[a, b]$ is a sequence, Δ , of numbers

$$a = t_0 < t_1 < t_2 \cdots < t_k \cdots < t_{n-1} < t_n = b$$

The *norm* of the partition, denoted by $\|\Delta\|$, is the largest length of any interval between successive members of Δ .

$$\|\Delta\| = \text{Max}\{t_1 - t_0, t_2 - t_1, \cdots, t_k - t_{k-1}, \cdots, t_n - t_{n-1}\}$$

Definition 9.4.3 Approximating sum to an integral. Suppose f is a function defined on an interval $[a, b]$. An approximating sum for the integral of f on $[a, b]$ is a number of the form

$$f(\tau_1) \times (t_1 - t_0) + f(\tau_2) \times (t_2 - t_1) + \cdots + f(\tau_k) \times (t_k - t_{k-1}) + \cdots + f(\tau_n) \times (t_n - t_{n-1})$$

where $a = t_0 < t_1 < t_2 \cdots < t_{n-1} < t_n = b$ is a partition of $[a, b]$ and

$$t_0 \leq \tau_1 \leq t_1 \quad t_1 \leq \tau_2 \leq t_2 \quad \cdots \quad t_{k-1} \leq \tau_k \leq t_k \quad \cdots \quad t_{n-1} \leq \tau_n \leq t_n$$

Definition 9.4.4 The integral of a function, II. Suppose f is an increasing function defined on an interval $[a, b]$. The *integral* of f on $[a, b]$ is denoted by $\int_a^b f(t) dt$ and defined by

$$\int_a^b f(t) dt = \lim_{\|\Delta\| \rightarrow 0} \sum_{k=1}^n f(\tau_k) \times (t_k - t_{k-1}) \quad (9.16)$$

Implicit in the previous symbol is that $\Delta = a = t_0 < t_1 < t_2 \cdots < t_k \cdots < t_{n-1} < t_n = b$ is a partition of $[a, b]$ and that $t_{k-1} \leq \tau_k \leq t_k$ for $k = 1, n$.

The two definitions of integral give a unique number and the same number for all increasing functions and for all decreasing functions and for all functions that alternate between increasing and decreasing only a finite number of times on $[a, b]$. Definition I is easier to comprehend, but the flexibility in Definition II in computing the approximating sum is sometimes helpful.

There are some functions for which either the limits in Definitions I and II are different or do not exist. It is unlikely that you will encounter one in undergraduate study, and we will not discuss them. We will assume that for all functions we deal with, the limits in Definitions I and II exist and are the same. For such functions, we say the the integral exists and we say the functions are integrable.

Exercises for Section 9.4, The Integral.

Exercise 9.4.1 a. The area formulas shown in Exercise Figure 9.4.1 were shown to be valid in Section 9.2 and are summarized in Equations 9.8 found in Exercise 9.2.12. Write these area formulas as integral formulas. One of them, for example, will be

$$\int_0^x t^2 dt = \frac{x^3}{3}$$

b. Write a formula for

$$\int_0^x t^n dt, \quad \text{valid for } n = 1, 2, 3, \dots \tag{9.17}$$

Figure for Exercise 9.4.1 Area formulas established in Section 9.2.

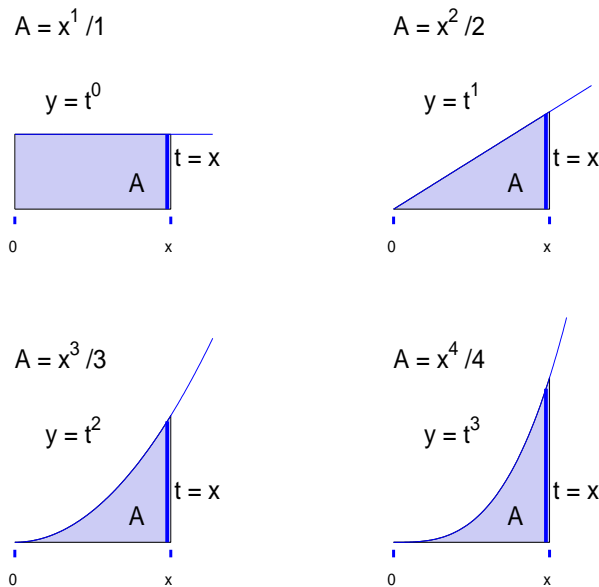

Exercise 9.4.2 Use Equation 9.17 in Exercise 9.4.1, to compute

a. $\int_0^1 t^2 dt$ b. $\int_0^2 t^2 dt$ c. $\int_1^2 t^2 dt$

Exercise 9.4.3 Use Equation 9.17 in Exercise 9.4.1, to compute

a. $\int_0^1 t dt$ b. $\int_1^2 t dt$

Exercise 9.4.4 Use Equation 9.17 in Exercise 9.4.1, to compute

a. $\int_0^1 t^3 dt$ b. $\int_1^2 t^3 dt$

Exercise 9.4.5 Use Equation 9.17 in Exercise 9.4.1, to compute

A. $\int_0^1 3 dt$ B. $\int_1^2 3 dt$

Exercise 9.4.6 Approximate

A. $\int_0^1 e^t dt$ B. $\int_0^\pi \sin(t) dt$

using the approximating sum in Definition 9.4.1 and 10 equal subintervals.

Exercise 9.4.7 Use Definition of Integral II to evaluate

$$\int_1^2 \frac{1}{t^2} dt. \tag{9.18}$$

Partition $[1,2]$ in n equal subintervals by

$$t_0 = 1, \quad t_1 = 1 + \frac{1}{n}, \quad \dots, \quad t_{k-1} = 1 + \frac{k-1}{n}, \quad t_k = 1 + \frac{k}{n}, \quad \dots, \quad t_n = 1 + \frac{n}{n}.$$

Let

$$\tau_k = \sqrt{t_{k-1} \times t_k}, \quad k = 1, 2, \dots, n$$

- a. Show that $t_{k-1} \leq \tau_k \leq t_k$.
- b. Write Equation 9.16,

$$\int_a^b f(t) dt = \lim_{\|\Delta\| \rightarrow 0} \sum_{k=1}^n f(\tau_k) \times (t_k - t_{k-1}),$$

for $\int_1^2 \frac{1}{t^2} dt$, the given partition and values of τ_k .

- c. Show that

$$\int_1^2 \frac{1}{t^2} dt = \lim_{\|\Delta\| \rightarrow 0} \sum_{k=1}^n \left(\frac{1}{t_{k-1}} - \frac{1}{t_k} \right)$$

- d. Write the previous sum in long form and show that

$$\int_1^2 \frac{1}{t^2} dt = \lim_{\|\Delta\| \rightarrow 0} \left(1 - \frac{1}{2} \right) = \frac{1}{2}$$

Exercise 9.4.8 Use steps similar to those of Exercise 9.18 to show that for $x > 1$,

$$\int_1^x \frac{1}{t^2} = 1 - \frac{1}{x}$$

Exercise 9.4.9 You will use this exercise in your proof of the Fundamental Theorem of Calculus, Theorem 10.2.1. Suppose f , is a continuous defined on an interval $[a, b]$ and $(v, f(v))$ is a high point of f on $[a, b]$ (meaning that v is in $[a, b]$ and for all x in $[a, b]$, $f(x) \leq f(v)$).

- a. Argue that every approximating sum for $\int_a^b f(x) dx$ is less than or equal to $f(v) \times (b - a)$.
- b. Argue that

$$\int_a^b f(x) dx \leq f(v) \times (b - a)$$

- c. Argue that if $(u, f(u))$ is a low point of f on $[a, b]$, then $f(u) \times (b - a) \leq \int_a^b f(x) dx$.

Exercise 9.4.10 In previous sections, values of the following integrals were given. What are they?

A. $\int_0^1 \frac{1}{1+t^2} dt = \text{_____}$ B. $\int_1^2 \frac{1}{t} dt = \text{_____}$

Exercise 9.4.11 Write an integral that is the area of the region bounded by the graphs of

- a. $y = t^2 - t$ and $y = 0, t = 1, t = 2$.
- b. $y = t^2,$ and $y = t, t = 1, t = 2$.
- c. $y = t^2,$ and $y = t, t = 0, t = 1$.
- d. $y = 2 \times t^5 - t^4,$ and $y = 0, t = 1, t = 2$.
- e. $y = 2 \times t^5,$ and $y = t^4, t = 1, t = 2$.

It is useful to sketch the regions.

Exercise 9.4.12 Suppose a particle moves with a velocity, $v(t) = \frac{1}{1+t^2}$.

- a. Write an integral that is the distance moved by the particle between times $t = 0$ and $t = 1$.

b. Write an integral that is the distance moved by the particle between times $t = -1$ and $t = 1$.

Exercise 9.4.13 Suppose an item is drawn from a normal distribution that has mean 0 and standard deviation 1 ($p(x) = \frac{1}{\sqrt{2\pi}} e^{-x^2/2}$). Write an integral for the probability that the item is

a. less than one standard deviation from the mean.

b. less than two standard deviations from the mean.

Exercise 9.4.14 Suppose water is flowing into a barrel at the rate of $R(t) = 1 + t^2$ m³/min for $0 \leq t \leq 3$ minutes. Write an integral that is the volume of water put into the tank. Confirm that the units on the integral are volume.

Exercise 9.4.15 Water flows into a tank at the rate of $R(t) = 1 + t^2/5$ m³/min for $0 \leq t \leq 3$ minutes and the concentration of salt in the water is $C(t) = 3.5e^{-t}$ g/l at time t . Write an integral that is the total amount of salt that flowed into the tank. Confirm that the units on the integral are grams of salt.

Exercise 9.4.16 Write an integral that is the work done in compressing a syringe of stroke 10cm and radius of 1cm from 10 to 5 cm. Confirm that the units on the integral are of units of work.

Exercise 9.4.17 What is the norm of the partition $\{0.0, 0.2, 0.3, 0.6, 0.7, 0.9, 1.0\}$ of $[0, 1]$? Write a partition of $[0, 1]$ whose norm is 0.15.

Exercise 9.4.18 Write an approximating sum to the given integrals for the partition $\{0.0, 0.2, 0.3, 0.6, 0.7, 0.9, 1.0\}$ of $[0, 1]$.

$$\begin{array}{ll} \text{a. } \int_0^1 1 \, dx & \text{d. } \int_0^1 x^2 \, dx \\ \text{c. } \int_0^1 e^x \, dx & \text{d. } \int_0^1 \sin(\pi x) \, dx \end{array}$$

Exercise 9.4.19 Average value of a function. The average value of a function f on an interval $[a, b]$ is defined to be

$$\text{Average value of } f \text{ on } [a, b] = \frac{1}{b-a} \int_a^b f(t) \, dt. \quad (9.19)$$

Use the approximating sum in Definition 9.4.1 and explain why

$$\frac{1}{b-a} \sum_{k=1}^n \left[f \left(a + k \times \frac{b-a}{n} \right) \times \frac{b-a}{n} \right]$$

is a reasonable approximation to the average value of f on $[a, b]$.

Exercise 9.4.20 Write the average solar intensity over a year for Eugene, Oregon in integral form. Assume that solar intensity is measured continuously 24 hours per day. See Exercise 9.1.3

Exercise 9.4.21 Let x be a number in $[0, \frac{\pi}{2}]$. Use the trigonometric identity

$$\sum_{k=1}^n \cos(k \times \theta) = \frac{\sin \left(n \times \theta + \frac{\theta}{2} \right) - \sin \left(\frac{\theta}{2} \right)}{2 \sin \left(\frac{\theta}{2} \right)} \quad \text{and} \quad \lim_{h \rightarrow 0} \frac{\sin(h)}{h} = 1$$

to compute from Definition I the integral

$$\int_0^x \cos(t) \, dt = \sin x$$

9.5 Properties of the integral.

Property 9.5.1 Linearity of the integral. Suppose f and g are integrable functions defined on an interval $[a, b]$ and c is a number. Then

$$\text{A.} \quad \int_a^b [f(t) + g(t)] dt = \int_a^b f(t) dt + \int_a^b g(t) dt \quad (9.20)$$

$$\text{B.} \quad \int_a^b c \times f(t) dt = c \times \int_a^b f(t) dt \quad (9.21)$$

The linearity properties are intuitive. If f is the rate of production of urea and g is the rate of production of creatinine, then $f + g$ is the rate of production of nitrogenous waste products. The total production of nitrogenous waste products ($\int_a^b (f(t) + g(t)) dt$) is the sum of the total production of urea ($\int_a^b f(t) dt$) and the total production of creatinine ($\int_a^b g(t) dt$). If the rate of production of urea is changed by a factor of c , then the total production of urea ($\int_a^b c \times f(t) dt$) is c times the previous production of urea ($c \int_a^b f(t) dt$).

The word *linear* is associated with these two properties, because linear functions of the form $P(x) = m \times x$ have the properties.

$$\begin{aligned} P(x + y) &= m \times (x + y) = m \times x + m \times y = P(x) + P(y) \\ P(c \times x) &= m \times (c \times x) = c \times (m \times x) = c \times P(x) \end{aligned}$$

The sine function is not linear, despite the efforts of many students. For most values of x and y

$$\sin(x + y) \neq \sin(x) + \sin(y).$$

Compare this with the trigonometric identity

$$\sin(x + y) = \sin(x) \cos(y) + \cos(x) \sin(y)$$

The reasons the integral has the two linearity properties is that the approximating sum also has the two properties. The integral being the limit of the approximating sums inherits the linearity properties of the approximating sums. For example, if f and g are functions defined on an interval $[a, b]$ and c is a number, and $a = t_0 < t_1 < t_2 \cdots < t_{n-1} < t_n = b$ is a partition of $[a, b]$ and

$$t_0 \leq \tau_1 \leq t_1 \quad t_1 \leq \tau_2 \leq t_2 \quad \cdots \quad t_{k-1} \leq \tau_k \leq t_k \quad \cdots \quad t_{n-1} \leq \tau_n \leq t_n$$

then

$$\begin{aligned} \text{A.} \quad \sum_{k=1}^n [f(\tau_k) + g(\tau_k)] \times (t_k - t_{k-1}) &= \sum_{k=1}^n f(\tau_k) \times (t_k - t_{k-1}) + \sum_{k=1}^n g(\tau_k) \times (t_k - t_{k-1}), \\ \text{B.} \quad \sum_{k=1}^n c \times f(\tau_k) \times (t_k - t_{k-1}) &= c \sum_{k=1}^n f(\tau_k) \times (t_k - t_{k-1}). \end{aligned}$$

Each approximating sum for $\int_a^b f(t) + g(t) dt$ is the sum of approximating sums for $\int_a^b f(t) dt$ and $\int_a^b g(t) dt$, and each approximating sum for $\int_a^b c \times f(t) dt$ is c times an approximating sum for $\int_a^b f(t) dt$.

Example 9.5.1 Compute

$$\text{A. } \int_0^1 [t^2 + t] dt \quad \text{B. } \int_0^2 2 \times t dt$$

Solution: A. By Equation 9.17 in Exercise 9.4.1, $\int_0^1 t^2 dt = \frac{1}{3}$, and $\int_0^1 t dt = \frac{1}{2}$. From Property 9.5.1 A,

$$\int_0^1 [t^2 + t] dt = \int_0^1 t^2 dt + \int_0^1 t dt = \frac{1}{3} + \frac{1}{2} = \frac{5}{6}$$

B. By Equation 9.17 in Exercise 9.4.1, $\int_0^2 t dt = 2$. From Property 9.5.1 B

$$\int_0^2 2t dt = 2 \times \int_0^2 t dt = 2 \times 2 = 4 \quad \blacksquare$$

Although many students think otherwise, it is not always (or even usually) true that

$$\int_a^b [f(t) \times g(t)] dt = \int_a^b f(t) dt \times \int_a^b g(t) dt \quad \text{Almost Never True!}$$

For example, let $f(t) = t^2$ and $g(t) = t$. Then

$$\int_1^2 f(t) \times g(t) dt = \int_1^2 t^2 \times t dt = \int_1^2 t^3 dt = \frac{15}{4},$$

but

$$\left(\int_1^2 f(t) dt \right) \times \left(\int_1^2 g(t) dt \right) = \left(\int_1^2 t^2 dt \right) \times \left(\int_1^2 t dt \right) = \left(\frac{8}{3} \right) \times \left(\frac{3}{2} \right) = 4 \neq \frac{15}{4}.$$

Also, it is not always true (and it is not even usually true) that

$$\int_a^b \frac{f(t)}{g(t)} dt = \frac{\int_a^b f(t) dt}{\int_a^b g(t) dt} \quad \text{Almost Never True!}$$

$$\int_1^2 \frac{f(t)}{g(t)} dt = \int_1^2 \frac{t^2}{t} dt = \int_1^2 t dt = \frac{3}{2},$$

but

$$\frac{\int_1^2 f(t) dt}{\int_1^2 g(t) dt} = \frac{\int_1^2 t^2 dt}{\int_1^2 t dt} = \frac{\frac{8}{3}}{\frac{3}{2}} = \frac{16}{9} \neq \frac{3}{2}.$$

Three more properties of the integral are:

Property 9.5.2 Geometry of the integral.

1. Suppose f is an integrable function defined on an interval $[a, b]$ and c is a number between a and b . Then

$$\int_a^c f(t) dt + \int_c^b f(t) dt = \int_a^b f(t) dt \quad (9.22)$$

2. Suppose f and g are integrable functions defined on an interval $[a, b]$ and for all t in $[a, b]$, $f(t) \leq g(t)$. Then

$$\int_a^b f(t) dt \leq \int_a^b g(t) dt \quad (9.23)$$

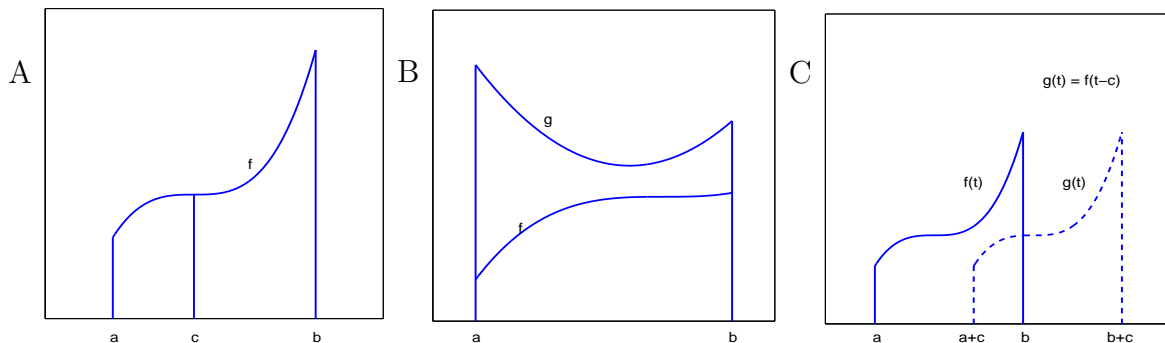

Figure 9.15: A. (Left) $\int_a^c f(t) dt + \int_c^b f(t) dt = \int_a^b f(t) dt$. B. (Center) The area under the graph of f is \leq the area under the graph of g . C. (Right) The area under the graph of f equals the area under the graph of g , where $g(t) = f(t - c)$.

3. Suppose f is an integrable function defined on $[a, b]$, and c is a number. Then

$$\int_{a+c}^{b+c} f(t - c) dt = \int_a^b f(t) dt \tag{9.24}$$

We refer to these as geometric properties because they are so obvious from the area interpretation of the integral. In Figure 9.15 A, it is clear that the area under the graph of f between $t = a$ and $t = b$ is the sum of the area between $t = a$ and $t = c$ and the area between $t = c$ and $t = b$. In Figure 9.15, B, it is clear that the area under the graph of f is less than the area under the graph of g . In Figure 9.15, C, the region below the graph of $g(t) = f(t - c)$ is a simple translation of the region under the graph of f and the areas are equal. Formal proofs of the properties based on approximating sums can be given, but the geometry alone is convincing, and we omit the formal proofs. Your solution to Explore 9.5.1 will give you some algebraic insight to the properties.

Explore 9.5.1 Remember from Definition 9.4.3 that an approximating sum for the integral of f on $[a, b]$ is a number of the form

$$f(\tau_1) \times (t_1 - t_0) + f(\tau_2) \times (t_2 - t_1) + \cdots + f(\tau_k) \times (t_k - t_{k-1}) + \cdots + f(\tau_n) \times (t_n - t_{n-1}).$$

Suppose f and g are continuous increasing functions defined on an interval $[a, b]$ and for every t in $[a, b]$, $f(t) \leq g(t)$ and suppose that c is a number.

- Show that every approximating sum of $\int_a^b f(t) dt$ is less than or equal to some approximating sum of $\int_a^b g(t) dt$.
- Show that every approximating sum to $\int_a^b f(t) dt$ is equal to an approximating sum to $\int_{a+c}^{b+c} f(t - c) dt$.
- Show that if $a < c < b$ and $S_{a,c}$ is an approximating sum for $\int_a^c f(t) dt$ and $S_{c,b}$ is an approximating sum for $\int_c^b f(t) dt$, then $S_{a,c} + S_{c,b}$ is an approximating sum for $\int_a^b f(t) dt$.

■

Explore 9.5.2 Which of properties 9.5.2 is illustrated by the following statements?

- a. John measures the rain fall from 2 to 4 pm and Jane measures the rain fall from 1400 to 1600 hours. They get the same amount.
- b. If Jane runs faster than John, Jane will go farther than John.
- c. The total damage done by the insects includes the damage done during the larval, pupal, and fully emerged insect stages.

■

Explore 9.5.3 Decide on a reasonable value for

$$\int_a^a f(t) dt \tag{9.25}$$

and give a geometric argument for your answer. ■

9.5.1 Negatives.

It has been assumed that in the symbol, $\int_a^b f(x) dx$, $a < b$. There are instances when one wants to extend the integral concept to the case $b < a$ and even the case $a = b$. This is done by

Definition 9.5.1 Suppose f is an integrable function defined on $[a, b]$. Then

$$\int_b^a f(t) dt = -\int_a^b f(t) dt \quad \text{and} \quad \int_a^a f(t) dt = 0$$

It has been implicit in much of the discussion that $f(x)$ is positive for all x in $[a, b]$. This is not required, and a number of instances suggest using functions with negative values.

Example 9.5.2 For example, a ball thrown vertically may have a positive velocity as it ascends, but will then have a negative velocity as it descends. If one throws the ball with a vertical velocity of $19.6m/s$, then the velocity t seconds later will be $19.6 - 9.8t m/s$ where the term $9.8t$ is the change in velocity due to gravity. A graph of the velocity is shown in Figure 9.16.

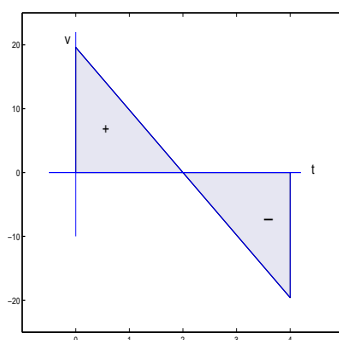

Figure 9.16: Velocity of a ball thrown vertically, $v(t) = 19.6 - 9.8t$.

At $t = 2$ seconds the velocity is zero, the ball is at its maximum height, and that height is the area of the triangle marked '+' in Figure 9.16. Between $t = 2$ and $t = 4$ seconds the velocity is negative, the motion of the ball is downward and the displacement is the area of the triangle marked '-' in Figure 9.16. At $t = 4$ the ball has fallen to its original starting point. The net displacement is zero and that is $\int_0^4 v(t) dt$, the sum of the 'areas' of the two triangles treating the area of the second triangle as negative (see Exercise 9.5.9). The *distance* traveled by the ball is the sum of the areas of the two triangles, both treated as positive. ■

Exercises for Section 9.5, Properties of the integral.**Exercise 9.5.1** Do Explore 9.5.1.**Exercise 9.5.2** Do Explore 9.5.2.**Exercise 9.5.3** Do Explore 9.5.3.**Exercise 9.5.4** Which of the linear properties of the integral are illustrated by the following examples?

- The death rate from cancer is about $2/3$'s that of heart disease. In a year's time $2/3$'s as many people die from cancer as die from heart disease.
- The common cold incidence is 0.348 per person per year and the influenza incidence is 0.254 per person per year. In three years, a town of 10,000 people experienced 18,060 respiratory viral infections.

Exercise 9.5.5 Is the exponential function, $E(x) = e^x$, linear? Prove or disprove.**Exercise 9.5.6** Is the logarithm function, $L(x) = \ln(x)$, linear? Prove or disprove.**Exercise 9.5.7** Compute (note: change x to t if it confuses you.)

$$\text{a. } \int_0^1 [3 + x^2] dx \quad \text{b. } \int_1^2 3x^2 dx \quad \text{c. } \int_3^5 3x^3 - 6x^2 dx$$

Exercise 9.5.8

$$\text{a. Compute: } P_1 \int_2^4 [t \times t^2] dt \quad \text{and} \quad P_2 \int_2^4 t dt \times \int_2^4 t^2 dt$$

$$\text{b. Compute: } Q_1 \int_2^4 \frac{t^3}{t^2} dt \quad \text{and} \quad Q_2 \frac{\int_2^4 t^3 dt}{\int_2^4 t^2 dt}$$

c. What do these two problems illustrate?

Exercise 9.5.9 In Example 9.5.2 it was claimed that $\int_0^4 v(t) dt = \int_0^4 (19.6 - 9.8t) dt$ is the sum of the areas of the two triangles in Figure 9.16. Compute

$$\text{a. } \int_0^2 (19.6 - 9.8t) dt, \quad \text{b. } \int_2^4 (19.6 - 9.8t) dt, \quad \text{and} \quad \text{c. } \int_0^4 (19.6 - 9.8t) dt.$$

Compare your answers with the areas of the triangles in Figure 9.16.

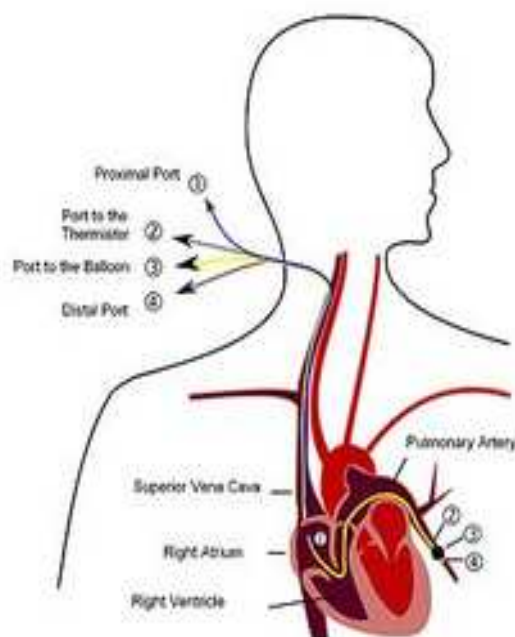

Figure 9.17: Schematic diagram of the heart and a Swan-Ganz catheter threaded throughout the right atrium and into the pulmonary artery, from http://en.wikipedia.org/wiki/Pulmonary_artery_catheter placed by Chikumaya.

9.6 Cardiac Output

The problems of this section are directed to understanding a procedure used for measuring cardiac output. Briefly, the procedure is

Infuse a quantity, Q , of 10°C saline solution into the right side of the heart, and measure the temperature of the fluid in the pulmonary artery exiting from the heart as a function of time, $T(t)$. Then the flow rate is

$$F = \frac{Q}{\int_0^\infty \frac{37-T(t)}{37-10} dt} \quad (9.26)$$

Our goal is to understand why Equation 9.26 correctly gives the flow rate. The following material describes the physiology and is copied from R.A. Rhoades and G. A. Tanner, *Medical Physiology.*, Little, Brown and Company, 1995, pp 271-2.

The Thermodilution Method. "In most clinical situations, cardiac output is measured using a variation of the dye dilution method called **thermodilution**. A **Swan-Ganz catheter** (a soft, flow-directed catheter with a balloon at the tip) is placed into a large vein and threaded through the right atrium and ventricle so that its tip lies in the pulmonary artery. The catheter is designed so a known amount of 10°C saline solution can be injected into the right side of the heart via a side pore in the catheter. This solution decreases the temperature of the surrounding blood. The magnitude of the decrease in temperature depends on the volume of blood that mixes with the solution, which depends on cardiac output. A thermistor on the catheter tip (located downstream in the pulmonary artery) measures the fall in blood temperature. Using calculations similar to the dye dilution method, the cardiac output can be determined."

Measurement of cardiac output as just described is a common procedure in hospitals. Patients returning from cardiac surgery have a Swan-Ganz catheter inserted as described. Measurements of cardiac output may be made hourly for the first 24 hours, followed by measurements every 2 hours for the next two days. You will find the web site of a catheter manufacturer, Edwards Lifesciences, interesting.

A useful first step in understanding Equation 9.26 is to check the units on the left and right hand side. The units on the integral are the same as the units on the approximating sums for the integral.

It is reasonable to assume that the flow rate, F , is measured in ml/sec so that the right hand side should also have units of ml/sec. The quantity, Q , should be measured in ml. A general approximating sum for the integral in the denominator is

$$\sum_{k=1}^n \frac{37 - T(t_k)}{37 - 10} (t_k - t_{k-1})$$

The fraction $\frac{37 - T(t_k)}{37 - 10}$ is the ratio of temperatures, and is therefore dimensionless. The factor $(t_k - t_{k-1})$ is measured in seconds, so that the unit on the approximating sum is seconds, as is the unit on the integral. Therefore the units on both sides of Equation 9.26 are ml/sec.

In order to understand the Equation 9.26 it is necessary to understand

“The magnitude of the decrease in temperature depends on the volume of blood that mixes with the solution, which depends on cardiac output. ”

and the next few examples and exercises are directed to that end.

Example 9.6.1 Suppose 10 ml of $9^\circ C$ water is mixed with 60 ml of $37^\circ C$ water. What will be the temperature of the mixture?

We base our answer on the concept of heat content in the fluids measured with a base of zero heat content at $0^\circ C$. It is helpful for this example that the specific heat of water is 1 calorie per gram-degree C. The definition of a calorie is the amount of heat required to raise one gram of water one degree centigrade — specifically from 14.5 to 15.5 degrees centigrade, but we will assume it is constant over the range 0 to 37 degrees centigrade.

The following table is helpful:

	Vol (ml)	Temp ($^\circ C$)	Calories
Fluid 1	10	9	$10 \times 9 = 90$
Fluid 2	60	37	$60 \times 37 = 2220$
Mixture	70	T	$70 \times T$

The critical step now is the conservation of energy. The calories in the mixture should be the sum of the calories in the two fluids (we assume there is no heat of mixing) so that

$$70 \times T = 90 + 2220 \qquad T = 33^\circ C \quad \blacksquare$$

Care must be taken when mixing two fluids of different heat capacities. If 10 ml of $9^\circ C$ cream is mixed with 60 ml of $37^\circ C$ coffee, the temperature of the mixture would be slightly more than 33° because the specific heat of cream is $0.9 \text{ cal/ml } ^\circ C$ and the specific heat of coffee is approximately that of water, $1.0 \text{ cal/ml } ^\circ C$.

Explore 9.6.1 Show that the temperature of mixture of 10 ml of 9°C cream and 60 ml of 37°C coffee would be approximately 33.35°C .

Suppose v_1 ml of fluid 1 at temperature T_1 and specific heat C_1 cal/ml are mixed with v_2 ml of fluid 2 at temperature T_2 and specific heat C_2 cal/ml. The temperature of the mixture will be

$$T_{mixture} = \frac{v_1 C_1 T_1 + v_2 C_2 T_2}{v_1 C_1 + v_2 C_2} \quad (9.27)$$

We now turn to the problem of measuring cardiac output. Suppose Q ml of 10°C saline solution are infused into the right side of the heart and the temperature $T(t)$ in the pulmonary artery is measured. Assume that the heat capacity of saline solution is the same as the heat capacity of blood and that flow rate past the thermometer is a constant, F . The concentration of saline solution at the thermometer is

$$K(t) = \frac{37 - T(t)}{37 - 10}$$

The amount of saline solution that passes the thermometer in time interval $[0, t_1]$ is

$$\int_0^{t_1} F \times K(t) dt = \int_0^{t_1} F \times \frac{37 - T(t)}{37 - 10} dt = F \times \int_0^{t_1} \frac{37 - T(t)}{37 - 10} dt.$$

Consider t_1 to mark the end of measurement and label it as ∞ . Then the amount of saline solution that passes the thermometer must also be Q , the amount injected. We can write

$$Q = F \times \int_0^\infty \frac{37 - T(t)}{37 - 10} dt, \quad \text{and} \quad F = \frac{Q}{\int_0^\infty \frac{37 - T(t)}{37 - 10} dt}.$$

Exercises for Section 9.6, Cardiac Output.

Exercise 9.6.1 Compute the units on the right side of Equation 9.27.

Exercise 9.6.2 Suppose 10°C saline solution is mixed with 50 ml of 37°C blood and the mixture is 35°C . How much saline solution was added? Assume equal heat capacities.

Exercise 9.6.3 Suppose 10°C saline solution is mixed with 25 ml of 37°C blood and the mixture is 32°C . How much saline solution was added? What is the concentration of saline solution in the total of the two fluids? Assume equal heat capacities.

Exercise 9.6.4 In Equation 9.27, assume that $C_1 = C_2$ and let $K = \frac{v_2}{v_1 + v_2}$ be the concentration of the second fluid in the total of the two fluids (we will think of blood as the first fluid and saline solution as the second fluid) and $Temp$ be the temperature of the mixture. Show that

$$K = \frac{T_1 - Temp}{T_1 - T_2} \quad (9.28)$$

Exercise 9.6.5 Fill in the blank entries in Table 9.6.5. Assume the heat capacities of blood and saline solutions are equal.

Table for Exercise 9.6.5 ARTIFICIAL DATA. GET REAL DATA FROM SWAN-GANZ CATHETER COMPANY. Fluid Temperature in the pulmonary artery after injection of 10 ml of 10°C saline solution in the right side of the heart.

Time (<i>sec</i>)	Temp ($^{\circ}\text{C}$)	0°C Saline Concentration (<i>ml/ml</i>)	Time (<i>sec</i>)	Temp ($^{\circ}\text{C}$)	0°C Saline Concentration (<i>ml/ml</i>)
0	37	0.000			
2	34	0.081	12	33	0.108
4	32	0.135	14	34	0.081
6	31	_____	16	35	0.054
8	32	_____	18	36	_____
10	32	_____	20	37	_____

Exercise 9.6.6 Based on the data in Table 9.6.5, if the heart flow rate is R ml/sec, how much saline solution passed the thermometer downstream of the heart during the time interval $[0, 20]$ sec?

Exercise 9.6.7 From the data in Table 9.6.5, what is the cardiac capacity?

Exercise 9.6.8 Seymour S. Kety and Carl F. Schmidt⁷ described a widely acknowledged and accurate method for determination of cerebral blood flow, and subsequent measurement of cerebral physiological activity such as cerebral rate of oxygen metabolism. It is commonly referred to as the Kety-Schmidt technique, and has the following outline:

1. An inert substance, σ , is introduced into the blood (patient breathes 15% N_2O or ^{133}Xe dissolved in saline is infused into the axillary vein, and other similar methods).
2. At times, t , after the start of administration, the arterial concentration, $A(t)$, of σ is measured in the radial artery.
3. The venous concentration, $V(t)$, of σ is measured at the base of the skull in the superior bulb of the internal jugular, at the point of exit of jugular vein from the brain.

Data read from curves shown in Kety and Schmidt, *Ibid.* are shown in Table 9.6.8.

Table for Exercise 9.6.8 Data read from Figure 1, on page 476, of C. M. Kety and S. S. Schmidt, *J. Clinical Invest.* **27**: 476-483, 1948.

⁷Kety, S. S, and Schmidt, C. M., The nitrous oxide method for the quantitative determination of cerebral blood flow in Man: Theory, procedure, and normal values, *J. Clinical Invest.* **27**: 476-483, 1948.

t	$A(t)$	$V(t)$
Min	*	*
0.00	0.0000	0.000
1.25	0.0320	0.012
3.25	0.0385	0.027
5.25	0.0410	0.034
10.00	0.0435	0.042
* Units for $A(t)$ and $V(t)$: cc N ₂ O/cc blood		

Assume a constant cerebral blood flow rate, R , grams/minute, that $A(t)$ is the concentration of N₂O (cubic centimeters of N₂O per cubic centimeter of blood) in blood flowing into the brain, and that $V(t)$ is the concentration of N₂O in blood flowing out of the brain.

- Using a flow rate, R (an unknown constant, units of cc blood/min), and the data, compute an estimate of the amount of N₂O that flowed into the brain during time $[0,10]$ (measured in minutes).
- Using R and the data, compute an estimate of the amount of N₂O that flowed out of the brain during time $[0,10]$.
- From the previous two steps you should be able to estimate that the amount of N₂O accumulated in the brain during time $[0,10]$ is approximately $R \times 0.0827$ cc N₂O.
- Note that after 10 minutes the venous and arterial concentrations of N₂O are about the same, indicating that the brain is essentially saturated. Assume that at 10 minutes the concentration of N₂O in the brain is $0.042 \frac{\text{cc N}_2\text{O}}{\text{cc brain}}$ (the same as $V(10)$), and compute the total amount of N₂O in a brain of 1400 cc⁸.
- Equate the two estimates of the amount of N₂O in the brain and compute R . (600 - 900 gm/min \doteq 600 - 900 ml/minute is normal for an adult; resting cardiac output is 5-6 L/minute.)
- Describe how knowledge of blood flow and two additional measurements can be used to compute cerebral metabolic uptake of oxygen.

9.7 Chlorophyll energy absorption.

Shown in Figure 9.18 are graphs of the energy absorbance of chlorophylls a and b and Solar Spectral Irradiance in $\text{W/m}^2/\text{nm} = \text{W}/(\text{m}^2 \times \text{nm})$. Note nm = nanometer = 10^{-9} meters.

Question: Which of chlorophyll a or chlorophyll b in leaves captures the most energy?

⁸Rhoads and Tanner, p 306, show brain mass = 1400 gm, we assume a brain density of 1gm/cc

Table 9.3: Chlorophyll Data read from a magnification of the upper graph in Figure 9.18. The irradiance data is read from a table from the Renewable Resource Data Center that appears in <http://rredc.nrel.gov/solar/spectral/am1.5ASTMG173/ASTMG173.html> and was the basis for the lower graph in Figure 9.18

Wavelength, λ_i	400	420	425	440	460	470	480	500	520	540
Chlorophyll <i>a</i>	0.35	0.47	0.54	0.23	0.03	0.0	0.0	0.0	0.0	0.0
Chlorophyll <i>b</i>	0.18	0.33	0.35	0.36	0.53	0.72	0.20	0.04	0.03	0.02
Irradiance	0.84	0.88	0.99	1.10	1.28	1.27	1.38	1.34	1.33	1.31
Wavelength, λ_i	560	580	600	620	630	640	660	675	680	700
Chlorophyll <i>a</i>	0.01	0.03	0.02	0.04	0.05	0.08	0.20	0.58	0.13	0.0
Chlorophyll <i>b</i>	0.03	0.04	0.05	0.17	0.39	0.16	0.04	0.02	0.01	0.0
Irradiance	1.31	1.35	1.33	1.33	1.26	1.30	1.27	1.26	1.27	1.16

Consider chlorophyll *a*. Energy absorbance in Figure 9.18 at a light frequency λ is measured by putting into a spectrophotometer a sample of chlorophyll *a*, dissolved in a solvent (diethyl ether, for example), and measuring light transmission, $I_{trans}(\lambda)$, through the sample from a light source I_0 of frequency λ , assumed to be constant for all λ . Then

$$\text{Energy Absorbance at } \lambda = \text{Absorb}(\lambda) = K \log_{10} \frac{I_0}{I_{trans}(\lambda)}. \quad (9.29)$$

K is measured in $1/(\text{M}\cdot\text{cm}^2)$ reflects the molar concentration of chlorophyll, M , and thickness of the sample. For the purpose of comparing the two chlorophylls, we assume that $K = 1$.

We have added a vertical scale to the absorbance graph in Figure 9.18. The lowest value, 0, is consistent with Equation 9.29: when no light is absorbed, $I_{trans}(\lambda) = I_0$, $I_0/I_{trans}(\lambda) = 1$, and $\log_{10} I_0/I_{trans} = \log_{10} 1 = 0$. The largest value of the scale, 0.8, is chosen so that the range of the argument of the logarithm is not too large.

The fraction of I_0 that is absorbed is

$$\text{Fraction Absorbed}(\lambda) = \text{FracAbsorb}(\lambda) = \frac{I_0 - I_{trans}(\lambda)}{I_0} = 1 - 10^{-\text{Absorb}(\lambda)}. \quad (9.30)$$

FracAbsorb has dimension 1 (or is dimensionless).

We partitioned the visible spectrum (400 nm to 700 nm) into intervals with smaller intervals where the graphs change rapidly and measured data shown in Table 9.3 read from magnifications of the graphs in Figure 9.18.

At any light frequency, λ , the energy absorbed by chlorophyll *a* is

$$\text{Irradiance}(\lambda) \times \text{FracAbsorb}(\lambda)W/(\text{m}^2 \times \text{nm}),$$

and for an interval, $[p, q]$, of frequencies we approximate the energy absorbed in that interval as (think 'trapezoidal approximation')

$$\frac{\text{Irradiance}(p) \times \text{FracAbsorb}(p) + \text{Irradiance}(q) \times \text{FracAbsorb}(q)}{2} (q - p).$$

For the visible spectrum, $[400, 700]$, we estimate the total absorbance as

$$\sum_{i=1}^{19} \frac{\text{Irradiance}(\lambda_i) \times \text{FracAbsorb}(\lambda_i) + \text{Irradiance}(\lambda_{i+1}) \times \text{FracAbsorb}(\lambda_{i+1})}{2} (\lambda_{i+1} - \lambda_i).$$

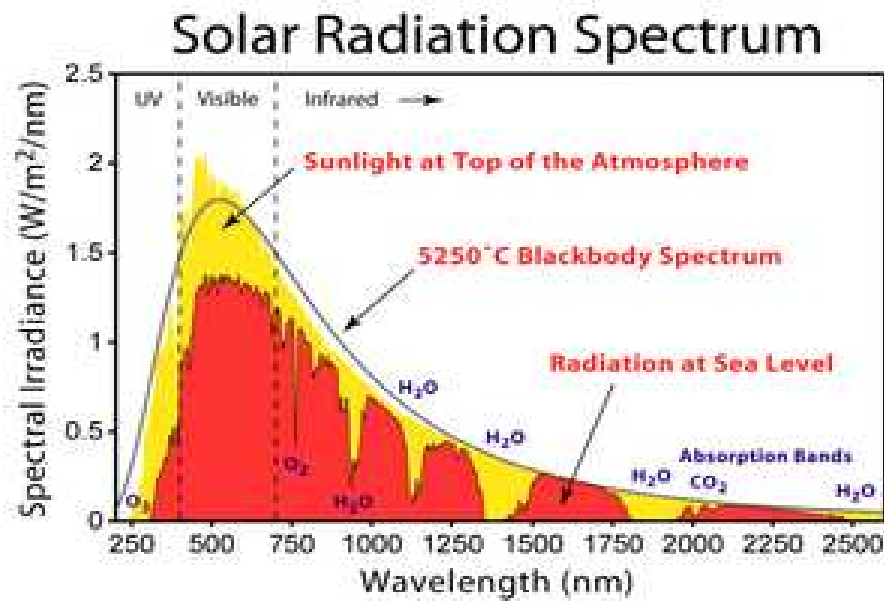
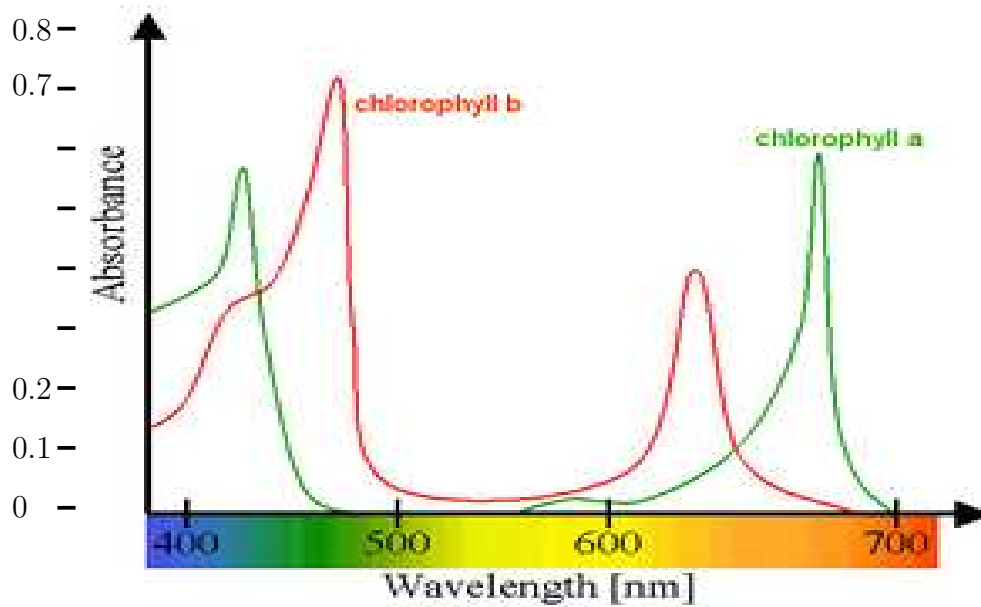

Figure 9.18: Upper graph. Energy absorption for chlorophylls *a* and *b*. Wikipedia Commons, http://en.wikipedia.org/wiki/File:Chlorophyll_ab_spectra.png Nashev and Luis Fernandez Garcia supplied the file and modifications. The vertical scale is added to provide a quantitative comparison between the two graphs. Lower graph. Solar Spectral Radiation $W/m^2/nm$ at sea level versus light wave length. Provided by Robert A. Rohde (Dragons flight) on Wikipedia, http://en.wikipedia.org/wiki/File:Solar_Spectrum.png.

Wave length, λ , is measured in nanometers, so the dimension is W/m^2 . The ultimate answer is

$$\int_{400}^{700} \text{Irradiance}(\lambda) \text{Absorbance}a(\lambda) d\lambda \quad \text{W}/\text{m}^2.$$

For chlorophyll a we get $59 \text{ W}/\text{m}^2$. You are asked to compute the total absorbance for chlorophyll b in Exercise ?? You should find that absorbance for chlorophyll b is about 52 percent greater than that for chlorophyll a . This is consistent, at least, with the observation that chlorophyll b is an evolutionary derivative of chlorophyll a .

Exercise 9.7.1 The computer program shown below computes the total absorbance of both chlorophylls. This problem is best if you can copy and run this program on your computer. Note: You can copy from the internet book and paste it in a blank MATLAB program sheet.

- Interpret the output which is: 58.9849 89.5865 1.5188.
- Three lines are commented out with `%%`. Delete the `%%` in the first two of these lines and interpret the result: 36.3818 55.8938 1.5363.
- Replace those two `%%`'s and delete the `%%` in the third line. Interpret the result: 53.7928 76.5903 1.4238.
- Delete the `%%` in each of the three lines and interpret the result: 33.6750 47.9500 1.4239.
- So far, what can you tell about the question, "Which of chlorophyll a or chlorophyll b in leaves captures the most energy from sunlight?"
- What additional information would you wish to have in order to give a more certain answer to the previous question?

```

%% Comparisons of Chlorophyll a and Chlorophyll b
close all;clc;clear

Lam= [400 420 425 440 460 470 480 500 520 540 560 ...
      580 600 620 630 640 660 675 680 700];
Chl_a= [0.35 0.47 0.54 0.23 0.03 0.0 0.0 0.0 0.0 0.0 0.0 0.01 ...
        0.03 0.02 0.04 0.05 0.08 0.20 0.58 0.13 0.0];
Chl_b= [0.18 0.33 0.35 0.36 0.53 0.72 0.20 0.04 0.03 0.02 0.03 ...
        0.04 0.05 0.17 0.39 0.16 0.04 0.02 0.01 0.0];
I=     [0.84 0.88 0.99 1.10 1.28 1.27 1.38 1.34 1.33 1.31 ...
        1.31 1.35 1.33 1.33 1.26 1.30 1.27 1.26 1.27 1.16];

ZZ = ones(size(Chl_a));
FA_a = ZZ - 10.^(-Chl_a);
FA_b = ZZ - 10.^(-Chl_b);

%% FA_a = Chl_a;
%% FA_b = Chl_b;
%% I = ZZ;

```



```

plot(Lam,FA_a,'g','linewidth',2); hold('on');
plot(Lam,FA_b,'r','linewidth',2)
plot(Lam,FA_a,'gd','linewidth',2);
plot(Lam,FA_b,'rs','linewidth',2)

N=length(I); Sum_a = 0.0; Sum_b = 0.0;
for i = 1:N-1
    Delta = Lam(i+1) - Lam(i);
    Sum_a = Sum_a + 0.5*(I(i)*FA_a(i)+I(i)*FA_a(i+1))*Delta;
    Sum_b = Sum_b + 0.5*(I(i)*FA_b(i)+I(i)*FA_b(i+1))*(Delta);
end
[Sum_a Sum_b Sum_b/Sum_a]

```

Exercise 9.7.2 There is a reason why the computer program using $FracAbsorb(\lambda)$ (original program) and $Absorbance(\lambda)$ with the first two %%'s removed) give similar results, including similar graphs. The reason involves the Taylor polynomial

$$e^{-x} = 1 - x + \frac{x^2}{2} - \frac{x^3}{6} + \frac{x^4}{24} \quad \text{where } 0 \leq x \leq c.$$

See Exercise 12.7.6.

Exercise 9.7.3 Write an integral that is the energy absorbed by chlorophyll b over the visible spectrum from 400 to 700 nm.

Exercise 9.7.4 Should we also consider possible chlorophyll absorbance of light in the ultra violet range of light wave length (< 400 nm)?

Chapter 10

The Fundamental Theorem of Calculus

Where are we going?

You should conclude from the title that this chapter is important.

You have studied the two primitive concepts of calculus, the derivative and the integral. They are based on the notion of limit, but each concept has been defined without reference to the other. **The Fundamental Theorem of Calculus** defines the relation between the derivative and the integral, and shows that each operation is the inverse of the other. A powerful method of evaluating integrals is a result.

10.1 An Example.

Let A be the function defined by

$$A(x) = \int_0^x \sin(t) dt \quad \text{for} \quad 0 \leq x \leq \frac{\pi}{2}$$

Then for x in $[0, \pi/2]$, $A(x)$ is the area of the region bounded by the graphs of

$$y = \sin t \quad y = 0 \quad \text{and} \quad t = x \quad (\text{see Figure 10.1A}).$$

We have two goals.

Goal I. Show that for any x , $0 \leq x \leq \pi/2$, $A'(x) = \sin(x)$

Goal II. Suggest (and it is actually true) that $A(x) = -\cos(x) + 1$ for $0 \leq x \leq \pi/2$.

Proof of Goal I, $A'(x) = \sin(x)$. We will show that the right hand derivative,

$$A'^+(x) = \lim_{h \rightarrow 0^+} \frac{A(x+h) - A(x)}{h} = \sin(x) \quad \text{for} \quad 0 \leq x < \pi/2.$$

A similar argument shows that the left hand derivative, $A'^-(x) = \sin x$ for $0 < x \leq \pi/2$, so that $A'(x) = \sin x$ on $0 \leq x \leq \pi/2$.

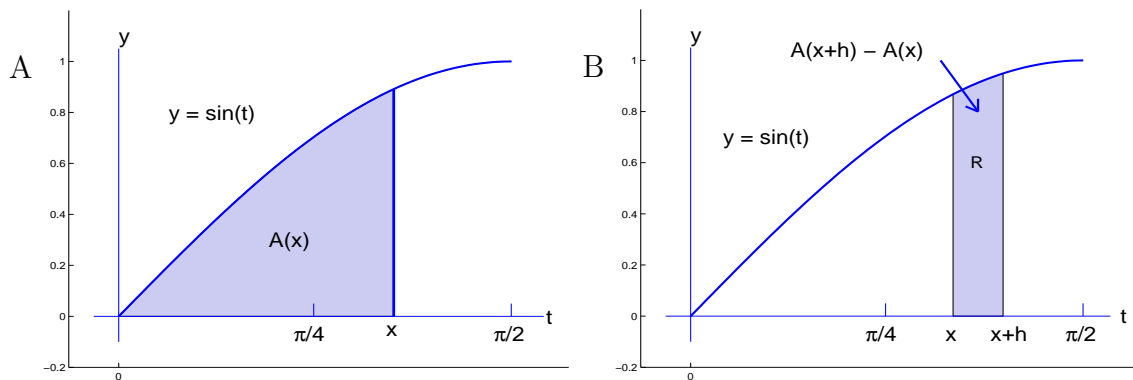

Figure 10.1: A. Area $A(x)$ of region bounded by the graphs of $y = \sin t$, $y = 0$ and $t = x$. B. Area of region between x and $x + h$.

Let x and $h > 0$ be numbers satisfying $0 \leq x < x + h \leq \pi/2$ and R be the region (shaded in Figure 10.1B) between $t = x$ and $t = x + h$ and below the graph of $y = \sin(x)$ and above $y = 0$. R is the difference of two regions under the graph of $y = \sin(x)$, one between $t = 0$ and $t = x + h$ and the other between $t = 0$ and $t = x$, and

$$\text{Area of } R \text{ is } A(x + h) - A(x) \tag{10.1}$$

In Figure 10.2A is a rectangle, R_1 , that is contained within R and the area of R_1 is less than the area of R . The height of R_1 is $\sin(x)$ and the width is h , so the

$$\text{Area of } R_1 \text{ is } \sin(x) h \tag{10.2}$$

In Figure 10.2B is a rectangle, R_2 , that entirely contains R and the area of R_2 is greater than the area of R . The height of R_2 is $\sin(x + h)$ and the width is h , so the

$$\text{Area of } R_2 \text{ is } \sin(x + h) h \tag{10.3}$$

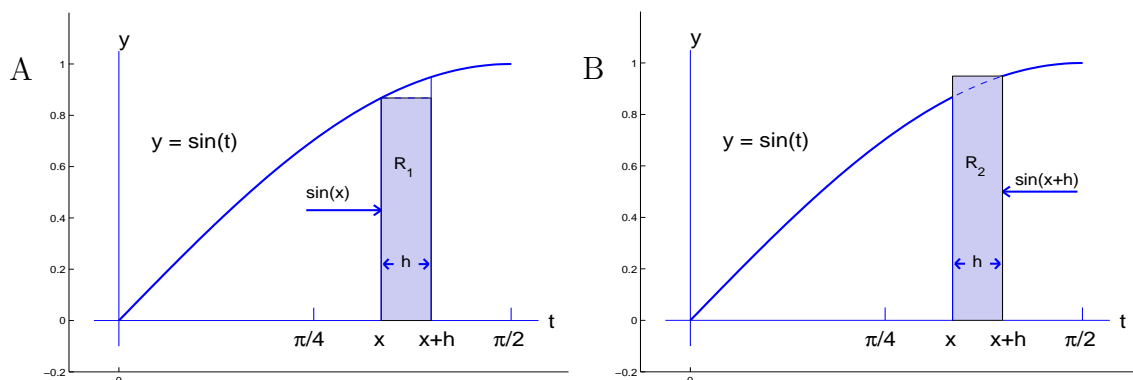

Figure 10.2: A. Rectangle R_1 of area $(\sin x) h$. B. Rectangle R_2 of area $(\sin(x + h)) h$.

We conclude from

$$\text{Area of } R_1 < \text{Area of } R < \text{Area of } R_2$$

and from Equations 10.1 to 10.3 that (remember, $h > 0$)

$$\sin(x) h < A(x+h) - A(x) < \sin(x+h) h$$

$$\sin(x) < \frac{A(x+h) - A(x)}{h} < \sin(x+h)$$

Now

$$a. \qquad \qquad \qquad b. \qquad \qquad \qquad c.$$

$$\sin(x) < \frac{A(x+h) - A(x)}{h} < \sin(x+h) \tag{10.4}$$

$$\text{As } h \longrightarrow 0+ \qquad \downarrow \qquad \qquad \downarrow \qquad \qquad \downarrow$$

$$\sin(x) \leq A^+(x) \leq \sin(x)$$

from which it follows that

$$A^+(x) = \sin(x) \quad \text{for} \quad 0 \leq x < \frac{\pi}{2}$$

The three limits, a., b. and c. in Equation 10.4 are important. Limit a. is valid because $\sin x$ is independent of h . Limit b. is the definition of the righthand derivative, A^+ . Limit c. is correct because $\sin x$ is continuous at x , which is shown in Exercise 7.1.4.

Our argument has assumed that $h > 0$ and $0 \leq x < \pi/2$. Simple modifications of the argument imply that $A^-(x) = \sin x$ for $0 < x \leq \pi/2$. so that $A'(x) = \sin x$ for $0 < x < \pi/2$. The domain of A is $[0, \pi/2]$, and by definition $A'(0) = A^+(0) = \sin 0$ and $A'(\pi/2) = A^-(\pi/2) = \sin \pi/2$. Goal I has been met.

Argument supporting Goal II, $A(x) = -\cos(x) + 1$. We know that $A'(x) = \sin(x)$. Derivative formulas will yield

$$[-\cos(x)]' = \sin(x).$$

Thus $A(x)$ and $-\cos(x)$ have the same derivative, $\sin(x)$. We might think, then, that because $A(x)$ and $-\cos(x)$ have the same derivative, they must be the same functions. That is too strong because constant functions have derivative = 0, and, for example,

$$[-\cos(x) + 13]' = \sin(x), \quad \text{also.}$$

But we can conclude (as we will see in Theorem 10.3.2) that there is a number C such that

$$A(x) = -\cos(x) + C$$

Now $A(0) = \int_0^0 \sin t dt = 0$, and $\cos(0) = 1$, so

$$\begin{aligned} A(0) &= -\cos(0) + C \\ 0 &= -1 + C \\ C &= 1 \end{aligned}$$

Therefore

$$A(x) = -\cos(x) + 1$$

Goal II has been met. *End of proof Goal I and argument for Goal II.*

We have obtained this formula **without reference to approximating sums**. This same formula was found in Example 9.4.4 **using the limit of approximating sums**.

In this chapter we give arguments for more general results, but the stepping stones for all of them are those we have just shown.

10.2 The Fundamental Theorem of Calculus.

Theorem 10.2.1 The Fundamental Theorem of Calculus. Suppose f is a continuous function defined on an interval $[a, b]$ and G is the function defined for every x in $[a, b]$ by

$$G(x) = \int_a^x f(t) dt$$

Then for every x in $[a, b]$

$$G'(x) = f(x)$$

Proof of the Fundamental Theorem of Calculus. We prove the theorem for the case that f is increasing. Suppose f is an increasing and continuous function defined on $[a, b]$ and for each x in $[a, b]$, $G(x) = \int_a^x f(t) dt$. We will prove that the right hand derivative

$$G'^+(x) = \lim_{h \rightarrow 0^+} \frac{G(x+h) - G(x)}{h} = f(x) \quad \text{for } a \leq x < b.$$

A simple modification of the argument shows that $G'^-(x) = f(x)$ for $a < x \leq b$, so that $G'(x) = f(x)$ for $a \leq x \leq b$.

Proof that $G'^+(x) = f(x)$. Let x and $x + h$ be numbers in $[a, b]$ with $h > 0$. Refer to Figure 10.3.

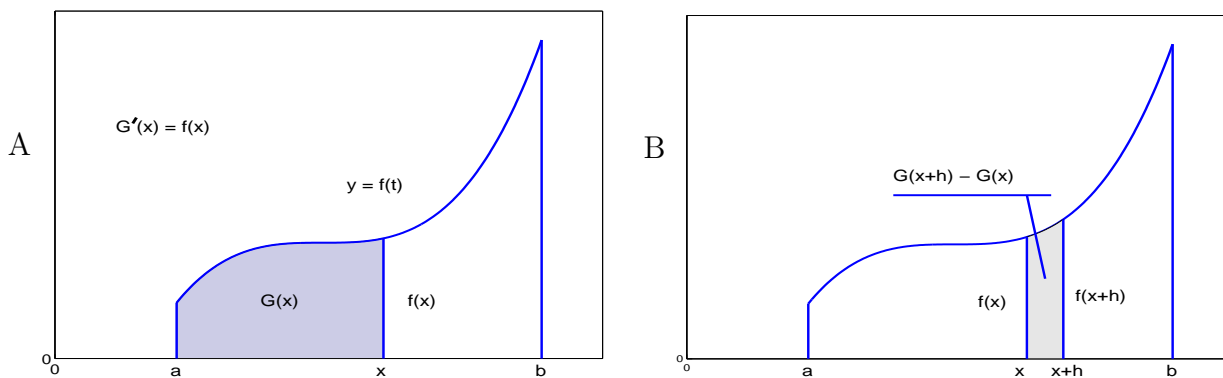

Figure 10.3: A. $G(x) = \int_a^x f(t) dt$. B. $G(x+h) - G(x) = \int_x^{x+h} f(t) dt$.

Explore 10.2.1 Do This. Give reasons for the steps (i), \dots , (viii), below. You will need the results of Exercise 9.4.9, that if $(u, f(u))$ and $(v, f(v))$ are, respectively, low and high points for a continuous function, f , on an interval, $[p, q]$, then $f(u)(q - p) \leq \int_p^q f(x) dx \leq f(v)(q - p)$.

$$G(x) = \int_a^x f(t) dt \tag{i}$$

$$G(x + h) = \int_a^{x+h} f(t) dt \tag{ii}$$

$$= \int_a^x f(t) dt + \int_x^{x+h} f(t) dt \tag{iii}$$

$$G(x + h) - G(x) = \int_x^{x+h} f(t) dt \tag{iv}$$

$$f(x) h \leq G(x + h) - G(x) \tag{v}$$

$$G(x + h) - G(x) \leq f(x + h) h \tag{vi}$$

$$f(x) h \leq G(x + h) - G(x) \leq f(x + h) h \tag{vii}$$

$$f(x) \leq \frac{G(x + h) - G(x)}{h} \leq f(x + h) \tag{viii}$$

■

We now examine what happens to the three terms in the inequality string

$$\text{(x)} \qquad \qquad \text{(xi)} \qquad \qquad \text{(xii)}$$

$$f(x) \leq \frac{G(x + h) - G(x)}{h} \leq f(x + h)$$

as h gets close to zero.

(x) Because $f(x)$ is not affected by h , $f(x)$ remains fixed as h gets close to zero.

Explore 10.2.2 Do This. Give reasons for (xi) and (xii).

$$\text{(xi)} \qquad \lim_{h \rightarrow 0^+} \frac{G(x + h) - G(x)}{h} = G'^+(x)$$

$$\text{(xii)} \qquad \lim_{h \rightarrow 0^+} f(x + h) = f(x)$$

■

We conclude that

$$\text{(x)} \qquad \qquad \text{(xi)} \qquad \qquad \text{(xii)}$$

$$f(x) \leq \frac{G(x + h) - G(x)}{h} \leq f(x + h)$$

$$\text{As } h \rightarrow 0 \qquad \downarrow \qquad \qquad \downarrow \qquad \qquad \downarrow$$

$$f(x) \leq G'^+(x) \leq f(x)$$

It follows from $f(x) \leq G'^+(x) \leq f(x)$ that $G'^+(x) = f(x)$ for $a \leq x < b$. A slight modification of this argument shows that $G'^-(x) = f(x)$ for $a < x \leq b$. and we conclude that $G'(x) = f(x)$ for $a < x < b$. Because $G'(a) = G'^+(a)$ and $G'(b) = G'^-(b)$, $G'(x) = f(x)$ for $a \leq x \leq b$.

Slightly modified arguments yield the same conclusion for f a decreasing function.

End of proof.

Example 10.2.1 Although technical in statement, the Fundamental Theorem of Calculus agrees with your intuition.

1. If $v(t)$ is the velocity of a particle at time t , then $G(x) = \int_0^x v(t) dt$ is the displacement of the particle during the time interval $[0, x]$. The Fundamental Theorem of Calculus states that $G'(x)$, the rate of change of displacement, is $v(x)$, the velocity.
2. If $r(t)$ is the rate at which urea is produced in a patient without functional kidneys, then $G(x) = \int_0^x r(t) dt$ is the total amount of urea in the body x hours since the last dialysis. The Fundamental Theorem of Calculus states that $G'(x)$, the rate of change of total urea, is $r(x)$, the rate at which it is produced.
3. If $b(t)$ and $d(t)$ are the birth and death rates of a population at time t , then $r(t) = b(t) - d(t)$ is the growth rate (which may be negative). $G(x) = \int_0^x r(t) dt$ is the population increase (again, it could be decrease) during the time interval $[0, x]$. The Fundamental Theorem of Calculus states that $G'(x)$, the rate of change of population, is $r(x)$, the growth rate.
4. In Example Figure 10.2.1.1, for $1 \leq x \leq 4$, let $A(x)$ be the area of the region bounded by the graph of f , the t -axis, and the lines $t = 1$ and $t = x$. The rate at which the area, A , increases at x , $A'(x)$, is $f(x)$ the height of the graph at x .

Figure for Example 10.2.1.1 $A(x)$ is the area between the graph of f , the t -axis, $t = 1$ and $t = x$. $A'(x)$, the rate at which the area A increases at x , is $f(x)$.

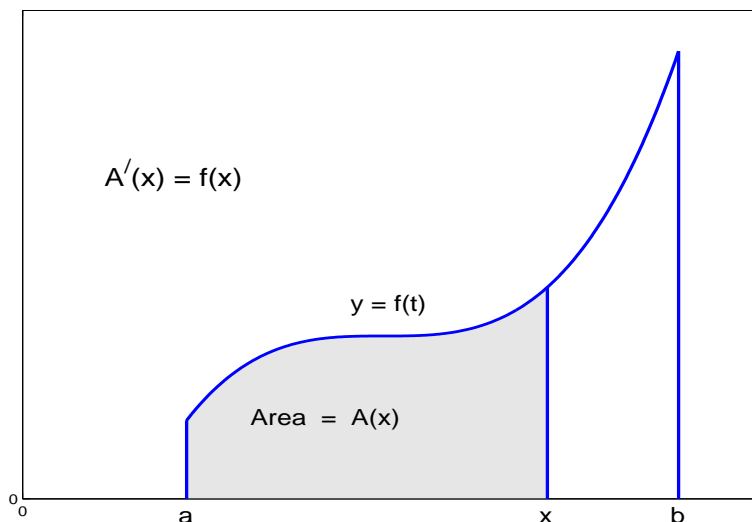

Exercises for Section 10.2, The Fundamental Theorem of Calculus.

Exercise 10.2.1 Work Explores 10.2.1 and 10.2.2

Exercise 10.2.2 a. Draw an approximation to the graph of the function G defined in Example Figure 10.2.1.1. Suggestion: Partition the interval $[1,4]$ into six equal subintervals, $[1.0, 1.5, 2.0, 2.5, 3.0, 3.5, 4.0]$ and estimate $f(1.0), f(1.5), \dots, f(4.0)$. Then estimate $G(1.0), G(1.5), \dots, G(4.0)$ using trapezoidal approximations.

b. Estimate $G'(1.5)$ using each of the three difference quotients:

Backward	Centered	Forward
$\frac{G(1.5) - G(1)}{1.5 - 1}$	$\frac{G(2) - G(1)}{2 - 1}$	$\frac{G(2) - G(1.5)}{2 - 1.5}$

The best estimate would normally be the centered difference quotient. Compare this estimate with your estimate of $f(1.5)$.

c. Use your data to estimate $G'(3.5)$ and compare your estimate of $G'(3.5)$ with $f(3.5)$.

Exercise 10.2.3 Let

$$f(t) = \frac{1}{\sqrt{2\pi}} e^{-t^2/2} \quad \text{and} \quad G(x) = \int_0^x f(t) dt = \int_0^x \frac{1}{\sqrt{2\pi}} e^{-t^2/2} dt$$

$G(x)$ is the area of the region bounded by the graphs of

$$y = f(t) = \frac{1}{\sqrt{2\pi}} e^{-t^2/2} \quad y = 0 \quad t = 0 \quad \text{and} \quad t = x$$

in Exercise Figure 10.2.3. Included in the figure are some data for both f and G .

Figure for Exercise 10.2.3 Graph of $f(t) = \frac{1}{\sqrt{2\pi}} e^{-t^2/2}$; $G(x)$ is the area of the shaded region between the graph of f , $y = 0$, $t = 0$ and $t = x$.

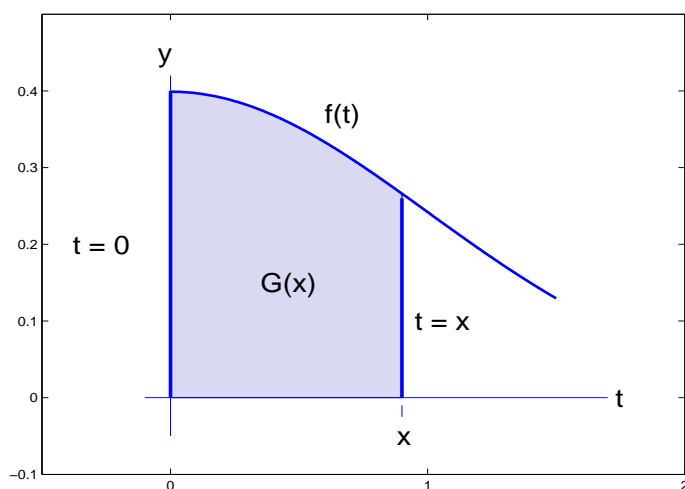

t	f(t)	x	G(x)
0.0	0.3989	0.0	0.0000
0.2	0.3910	0.2	0.0790
0.4	0.3683	0.4	0.1549
0.6	0.3332	0.6	0.2251
0.8	0.2897	0.8	0.2874
1.0	0.2420	1.0	0.3405
1.2	0.1942	1.2	0.3842

- Write the formula for $f(0.6)$ and evaluate it.
- Use the values of $f(0), f(0.2), f(0.4)$ and $f(0.6)$ and the trapezoidal approximation to estimate $G(0.6)$.

- c. Approximate $G'(1.0)$ from the data for G . using the backward, centered, and forward difference quotients and compare these estimates with $f(1.0)$.

Exercise 10.2.4 Let $G(x)$ be the area of the region bounded by the graphs of $y = \frac{1}{1+t^2}$, $y = 0$, $t = 1$ and $t = x$.

- Compute approximate values for $y(1.0)$, $y(1.5)$, $y(2.0)$, $y(2.5)$, and $y(3.0)$.
- Compute approximate values for $G(1.0)$, $G(1.5)$, $G(2.0)$, $G(2.5)$, and $G(3.0)$.
- Sketch the graph of $y = \frac{1}{1+t^2}$ on $[0,3]$.
- Sketch the graph of G on $[1,3]$.
- Estimate $G'(2)$.

Exercise 10.2.5 At 1:00 a.m. an oil pipe line bursts and starts releasing oil into a lake at the rate of 2 cubic meters per hour. At 2:00 a.m., a second oil pipe line bursts and also starts releasing oil into the lake at the rate of 3 cubic meters per hour.

- How much oil is in the lake at 1:00, 1:30, 2:00, 2:30, 3:00, 3:30, and 4:00?
- Let $T(x)$ be the total amount of oil in the lake at time x . Draw a graph of T .
- Write equations describing the total amount of oil, $T(x)$, in the lake for each time x between 1:00 a.m. and 4:00 a.m.
- Compute T' .

Exercise 10.2.6 This problem illustrates the necessity of the hypothesis that f be continuous in the statement of the Fundamental Theorem of Calculus. Remember that the integral is defined for any nondecreasing function. Let

$$f(t) = \begin{cases} 1 & \text{For } 1 \leq t < 2 \\ 2 & \text{For } 2 \leq t \leq 4 \end{cases}$$

For each x in $[1, 4]$, let $G(x)$ be the area of the region between the graph of f and the horizontal axis and between $t = 1$ and $t = x$. See Exercise Figure 10.2.6

- Compute $G(1.0)$, $G(1.5)$, $G(2.0)$, $G(2.5)$, $G(3.0)$, $G(3.5)$ and $G(4.0)$.
- Draw a graph of G .
- Write equations describing G .
- Write $G(x)$ as an integral.
- Compute and draw the graph of G' .
- G' and f are not the same function. What is the difference?

Figure for Exercise 10.2.6 Graph of f where $f(t) = 1$ for $1 \leq t < 2$ and $f(t) = 2$ for $2 \leq t \leq 4$ and the region G bounded by the graph of f , $y = 0$, $t = 1$ and $t = x$.

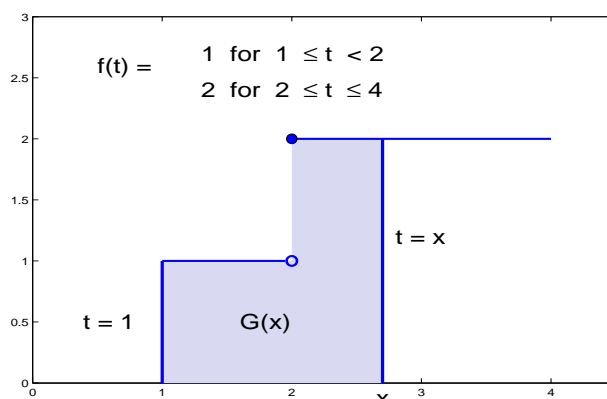

Exercise 10.2.7 Let $F(t) = [t]$ where $[t]$ is the greatest integer less than or equal to t . For example, $[\pi] = 3$, and $[2] = 2$. Let $G(x) = \int_0^x f(t) dt$ for $0 \leq x \leq 4$.

- Sketch the graph of f for $0 \leq t \leq 5$
- Sketch the graph of G .
- Sketch the graph of G' .
- You should find that $G' \neq f$. Does this contradict the Fundamental Theorem of Calculus?

Exercise 10.2.8 Use your calculator to solve the previous problem (slowly). In GRAPH, use MORE to find FORMT. Under FORMT select DrawDOT. In GRAPH go to $y(x) =$. Write 'y1 = int x'. You can find 'int' in 2nd MATH NUM. Write 'y2 = fnInt(y1,x,0,x)'. You can find fnInt in 2nd CALC. Set your window to $0 \leq x \leq 4$, $0 \leq y \leq 6$. Press DRAW. Your calculator will draw the graph of f and the graph of G . Plan to work some other problems while you wait. It takes about 12 minutes to compute.

Exercise 10.2.9 The following two MATLAB 'm' files solve Exercise 10.2.7.

```
File 1    myfun_floor.m
          function y=myfun_floor(x)
          y=floor(x);
```

```
File 2    test_int.m
          close all;clc;clear
          z=[0:0.01:4];    u=floor(z);
          for k=1:length(z)
              v(k)=quadgk(@myfun_floor,0,z(k),'waypoints',[1,2,3]);
          end
          plot(z,u,'.');    hold('on');    plot(z,v,'r.')
```

`myfun_floor.m` and `test_int.m` should be in the same directory. Issue the MATLAB command, `test_int` In MATLAB, `floor(z)` rounds the elements of `z` to the nearest integers towards minus infinity.

10.3 The parallel graph theorem.

The Parallel Graph Theorem is needed in order to make full use of the Fundamental Theorem of Calculus. A preliminary version is the Horizontal Graph Theorem.

Theorem 10.3.1 Horizontal Graph Theorem. If D is a continuous function defined on an interval $[a, b]$ and for every number x in (a, b) ,

$$D'(x) = 0,$$

then there is a number C such that for every number x in $[a, b]$

$$D(x) = C.$$

Proof. Let $C = D(a)$. Suppose x is in (a, b) . By the Mean Value Theorem 12.1.1 there is a number z between a and x such that

$$D(x) - D(a) = D'(z) (x - a).$$

Because $D'(z) = 0$, $D(x) - D(a) = 0$ and $D(x) = D(a) = C$. Because D is continuous and $D(x) = C$ for every x in $[a, b]$, $D(b) = C$.

End of proof.

An example of parallel graphs, that is, graphs which have the same derivative, is shown in Figure 10.4.

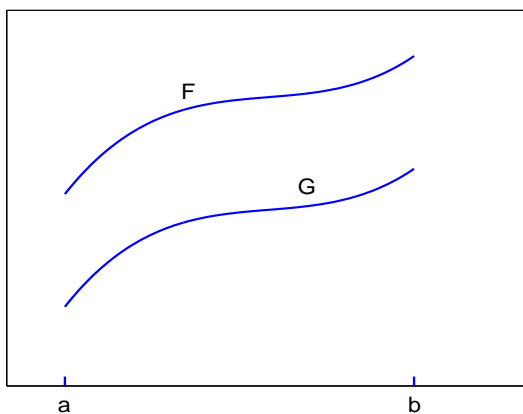

Figure 10.4: The graphs of F and G have the same derivative and are parallel.

Theorem 10.3.2 Parallel Graph Theorem. If F and G are functions defined on an interval $[a, b]$ and for every x in $[a, b]$

$$F'(x) = G'(x),$$

then there is a number, C , such that for every x in $[a, b]$

$$F(x) = G(x) + C$$

Proof. Let $D(x) = F(x) - G(x)$ for every x in $[a, b]$. Then

$$D'(x) = [F(x) - G(x)]' = F'(x) - G'(x) = 0$$

for every x in $[a, b]$. By the Horizontal Graph Theorem, Theorem 10.3.1, there is a number C such that for every x in $[a, b]$, $D(x) = C$. Then for every x in $[a, b]$

$$D(x) = F(x) - G(x) = C \quad \text{and} \quad F(x) = G(x) + C.$$

End of proof.

The power of the Fundamental Theorem of Calculus augmented by the Parallel Graph Theorem is illustrated by the next example.

Example 10.3.1 A 10cc syringe has cross-sectional area A cm²; air inside the plunger is atmospheric pressure P_0 which we assume to be 1 Atmosphere (1 Atm); the plunger is at the 10 cc mark and the neck of the syringe is blocked. The plunger is depressed a distance s/A to the $10 - s$ cc mark. Because at constant temperature, $PV = \text{a constant} = P_0 V_0$, the pressure, P_s , inside the syringe is $P_0 10/(10 - s)$. The force on the plunger is $(P_s - P_0) A = A P_0 (s/(10 - s))$. The work done in compressing the air from 10 cc to 5 cc is

$$\int_0^5 A P_0 \frac{s}{10 - s} d\frac{s}{A} = \int_0^5 P_0 \frac{s}{10 - s} ds$$

Let

$$W(x) = P_0 \int_0^x \frac{s}{10 - s} ds$$

Then the work done in compressing the air is $W(5)$. The Fundamental Theorem of Calculus asserts that

$$W'(x) = P_0 \frac{x}{10 - x}$$

Let $\omega(x)$ be defined by **(a bolt out of the blue!)**

$$\omega(x) = P_0 [-10 \ln(10 - x) - x]$$

Explore 10.3.1 Use derivative formulas including $f(t) = \ln U(t) \implies f'(t) = \frac{1}{U(t)} U'(t)$ to show that

$$\omega'(x) = P_0 \frac{x}{10 - x} \quad \blacksquare$$

Thus $W'(x) = \omega'(x)$ for every x in $[0, 5]$, and by the Parallel Graph Theorem there is a number C such that for every number x in $[0, 5]$

$$W(x) = \omega(x) + C$$

Now

$$W(0) = P_0 \int_0^0 \frac{s}{10-s} ds = 0, \quad \text{and}$$

$$\omega(0) = P_0 [-10 \ln(10-0) - 0] = -P_0 10 \ln 10.$$

Because $W(0) = \omega(0) + C$

$$0 = -P_0 10 \ln 10 + C \quad \text{and} \quad C = P_0 10 \ln 10.$$

We can conclude that for all x in $[0, 5]$

$$W(x) = P_0 [-10 \ln(10-x) - x] + P_0 10 \ln(10)$$

The total work done in compressing the air as

$$W(5) = P_0 [-10 \ln(10-5) - 5 + 10 \ln(10)] = P_0 1.93$$

In the previous example, we used the Fundamental Theorem of Calculus to evaluate the integral **without computing an approximating sum**. It was important to have a function, ω , satisfying $\omega' = W'$, and in a sense, the problem of computing approximating sums was exchanged for the problem of finding ω . Once we found such an ω , we appealed to the Parallel Graph Theorem to conclude that there was a number C such that for all x , $W(x) = \omega(x) + C$. **This is powerful medicine!**

Exercises for Section 10.3 The parallel graph theorem.

Exercise 10.3.1 Let $f(x) = [x]$ (= greatest integer less than or equal to x) $0 \leq x \leq 5$. Compute and draw the graph of f' . Is this an example showing that the Horizontal Graph Theorem, Theorem 10.3.1, is false?

Exercise 10.3.2 Suppose $P(t)$ is the size of a population at time t , $P(0) = 5000$, and $P'(t) = 0$ for all t . What is $P(100)$? What is $P(10000000000)$?

Exercise 10.3.3 Suppose a mold colony is growing in a nutrient solution and that on day zero the area was 0.5 cm^2 and for every time, $t \geq 0$, the instantaneous rate of growth of the area of the colony is $2t \text{ cm}^2$ per day. Let $P(t)$ be the colony area at time t .

- Argue that for every time, t , $P'(t) = 2t$.
- Show that for $Q(t) = t^2$, $Q'(t) = 2t$. Then $P'(t) = Q'(t)$.
- From the Parallel Graph Theorem, it follows that there is a constant C such that $P(t) = Q(t) + C$.
- Use $P(0) = 0.5$ to evaluate C .

- e. What is the area of the mold colony on day 8?

Exercise 10.3.4 Suppose the rate of glucose production in a corn plant is proportional to sunlight intensity and can be approximated by

$$R(t) = K (t + 7)^2 (t - 7)^2 = K (t^4 - 98t^2 + 2401) \quad -7 \leq t \leq 7$$

Time is measured so that sunrise is at -7 hours, the sun is at its zenith at 0 hours and sets at 7 hours. The quantity $Q(x)$ of glucose produced during the period $[-7, x]$ is

$$Q(x) = \int_{-7}^x R(t) dt = \int_{-7}^x K (t^4 - 98t^2 + 2401) dt = K \int_{-7}^x (t^4 - 98t^2 + 2401) dt$$

By the Fundamental Theorem of Calculus,

$$Q'(x) = K (x^4 - 98x^2 + 2401)$$

- Sketch the graph of $R(t)$. At what time is the sun most intense?
- Show that if $U(x) = \frac{x^5}{5}$ then $U'(x) = x^4$.
- Find an example of a function, $V(x)$ such that $V'(x) = -98x^2$.
- Find an example of a function, $W(x)$ such that $W'(x) = 2401$.
- Let $G(x) = K \left(\frac{x^5}{5} - \frac{98}{3}x^3 + 2401x \right)$. Show that $G'(x) = Q'(x)$.
- Conclude that there is a number, C , such that

$$Q(x) = G(x) + C = K \left[\frac{x^5}{5} - \frac{98}{3}x^3 + 2401x \right] + C$$

- Why is $Q(-7) = 0$.
- Evaluate C .
- Compute $Q(7)$, the amount of glucose produced during the day.

Exercise 10.3.5 “Based on studies using isolated animal pancreas preparations maintained in vitro, it has been determined that insulin is secreted in a biphasic manner in response to a marked increase in blood glucose. There is an initial burst of insulin secretion that may last 5 - 15 minutes, a result of secretion of preformed insulin secretory granules. This is followed by more gradual and sustained insulin secretion that results largely from biosynthesis of new insulin molecules. ” (Rhoades and Tanner, p710)

- A student eats a candy bar at 10:20 am. Draw a graph representative of the rate of insulin secretion between 10:00 and 11:00 am.
- Draw a graph representative of the amount of serum insulin between 10:00 and 11:00. Assume that insulin is degraded throughout 10 to 11 am at a rate equal to insulin production before the candy is eaten. and that serum insulin at 10:00 was I_0 .

- c. Write an expression for the amount of serum insulin, $I(t)$, for t between 10:00 and 11:00 am.

Exercise 10.3.6 Equal quantities of gaseous hydrogen and iodine are mixed resulting in the reaction

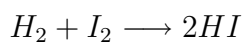

which runs until I_2 is exhausted (H_2 is also exhausted). The rate at which I_2 disappears is $\frac{0.2}{(t+1)^2}$ gm/sec. How much I_2 was initially introduced into the mixture?

- Sketch the graph of the reaction rate, $r(t) = \frac{0.2}{(t+1)^2}$.
- Approximately how much I_2 combined with H_2 during the first second?
- Approximately how much I_2 combined with H_2 during the second second?
- Let $Q(x)$ be the amount of I_2 that combines with H_2 during time 0 to x seconds. Write an integral that is $Q(x)$.
- What is $Q'(x)$?
- Compute $W'(x)$ for $W(x) = \frac{-0.2}{1+x}$.
- Show that there is a number, C , for which $Q(x) = W(x) + C$.
- Show that $C = 0.2$ so that $Q(x) = 0.2 - \frac{0.2}{1+x}$.
- How much I_2 combined with H_2 during the first second?
- How much I_2 combined with H_2 during the first 100 seconds?
- How much I_2 combined with H_2 ?

10.4 The Second Form of the Fundamental Theorem of Calculus

The Parallel Graph Theorem leads to a second form of the Fundamental Theorem of Calculus that has powerful applications.

Theorem 10.4.1 Fundamental Theorem of Calculus II. Suppose f is a continuous function defined on an interval $[a, b]$ and F is a function defined on $[a, b]$ having the property that

$$\text{for every number } t \text{ in } [a, b] \quad F'(t) = f(t) \quad (10.5)$$

Then

$$\int_a^b f(t) dt = F(b) - F(a). \quad (10.6)$$

Proof: Suppose the hypothesis of the theorem. Let G be the function defined on $[a, b]$ by

$$G(x) = \int_a^x f(t) dt$$

Explore 10.4.1 Do this. Give reasons for the steps (i), \dots , (v).

$$\text{For } x \text{ in } [a, b], G'(x) = f(x). \quad (\text{i})$$

$$\text{For } x \text{ in } [a, b], F'(x) = f(x). \quad (\text{ii})$$

$$\text{For } x \text{ in } [a, b], G'(x) = F'(x).$$

$$\text{There is a number } C \text{ so that for } x \text{ in } [a, b], \quad G(x) = F(x) + C \quad (\text{iii})$$

$$G(a) = 0. \quad (\text{iv})$$

$$G(a) = F(a) + C. \text{ Therefore, } C = -F(a).$$

$$G(x) = F(x) - F(a).$$

$$G(b) = F(b) - F(a).$$

$$\int_a^b f(t) dt = F(b) - F(a). \quad (\text{v}) \quad \blacksquare$$

End of proof.

Notation: The number $F(b) - F(a)$ is denoted by $[F(x)]_a^b$ or $F(x) \Big|_a^b$.

Example 10.4.1 You now have a powerful computational tool.

1. Evaluate $\int_0^1 t^2 dt$. Check that

$$\text{if } F(t) = \frac{t^3}{3} \quad \text{then} \quad F'(t) = \left[\frac{t^3}{3} \right]' = \frac{1}{3} [t^3]' = \frac{1}{3} 3t^2 = t^2.$$

It follows that

$$\int_0^1 t^2 dt = F(1) - F(0) = \left[\frac{t^3}{3} \right]_0^1 = \frac{1^3}{3} - \frac{0^3}{3} = \frac{1}{3}.$$

The integral is the area of the region bounded by the graphs of $y = t^2$, $y = 0$, and $t = 1$. The area was also found to be $\frac{1}{3}$ in Chapter 9 by use of rectangles and approximations.

2. Evaluate $\int_1^2 t^2 dt$. Using the same function, $F(t) = \frac{t^3}{3}$ we obtain that

$$\int_1^2 t^2 dt = F(2) - F(1) = \left[\frac{t^3}{3} \right]_1^2 = \frac{2^3}{3} - \frac{1^3}{3} = \frac{7}{3}$$

3. Evaluate $\int_0^5 5e^{0.02t} dt$. Observe that $F(t) = 250e^{0.02t}$ has the property that $F'(t) = 5e^{0.02t}$. Therefore

$$\int_0^5 5e^{0.02t} dt = F(5) - F(0) = [250e^{0.02t}]_0^5 = 250e^{0.02 \cdot 5} - 250e^{0.02 \cdot 0} \doteq 26.29$$

4. Evaluate $\int_1^2 \frac{1}{t} dt$. We found in Chapter 5 that $F(t) = \ln t \implies F'(t) = \frac{1}{t}$. Therefore,

$$\int_1^2 \frac{1}{t} dt = F(2) - F(1) = [\ln t]_1^2 = \ln 2 - \ln 1 = \ln 2$$

Exercises for Section 10.4, The Second Form of the Fundamental Theorem of Calculus.

Exercise 10.4.1 Do Explore exercise 10.4.1.

Exercise 10.4.2 Evaluate the integrals

Compute	Evaluate	Compute	Evaluate
a. $\left[\frac{t^6}{6}\right]'$	$\int_1^4 t^5 dt$	b. $\left[\frac{e^{2t}}{2}\right]'$	$\int_{-1}^2 e^{2t} dt$
c. $[\sin(2t)]'$	$\int_0^\pi \cos(2t) \cdot 2 dt$	d.	$\int_1^4 13 t^5 dt$
e.	$\int_1^4 t^3 dt$	f.	$\int_1^4 (t^3 + t^5) dt$
g. $\left[e^{\frac{t^2}{2}}\right]'$	$\int_0^1 e^{\frac{t^2}{2}} t dt$	h. $[\ln(1+t)]'$	$\int_0^2 \frac{1}{1+t} dt$
i. $[\ln(1+t^2)]'$	$\int_0^2 \frac{t}{1+t^2} dt$	j. $[\ln(1+y)]'$	$\int_0^1 \frac{1}{1+y} dy$
k. $[\ln(1-y)]'$	$\int_0^{0.5} \frac{1}{1-y} dy$	l. $\frac{1}{y} + \frac{1}{1-y}$	$\int_{0.25}^{0.75} \frac{1}{y(1-y)} dy$

Exercise 10.4.3 Evaluate the integrals.

- a. $\int_1^3 t^2 dt$ b. $\int_0^2 t^3 dt$ c. $\int_0^2 e^t dt$ d. $\int_1^3 \frac{1}{t} dt$ e. $\int_1^3 (1+t)^2 dt$
 f. $\int_1^3 5t dt$ g. $\int_0^2 t + 5 dt$ h. $\int_0^2 e^{2t} dt$ i. $\int_0^3 e^{-t} dt$ j. $\int_1^3 (1+t^2) dt$

Exercise 10.4.4 The graph in Figure 10.4.4 approximates the size, $S(t)$, of colon carcinoma cells t days after injection into mice (after Leach, D. R., et al, *Science* **271** (1996) 1734.)

- Read approximate values of $S(t)$ and $S'(t)$ from the curve.
- From the (completed) table of values of $S'(t)$ approximate $\int_{15}^{35} S'(t) dt$.
- Give a physical interpretation of $\int_{15}^{35} S'(t) dt$.
- Why would you expect $\int_{15}^{35} S'(t) dt$ to be approximately 130 according to data in the table?

Figure for Exercise 10.4.4 The size of carcinoma cells t days after injection into mice. Error bars that were on the original graph are omitted.

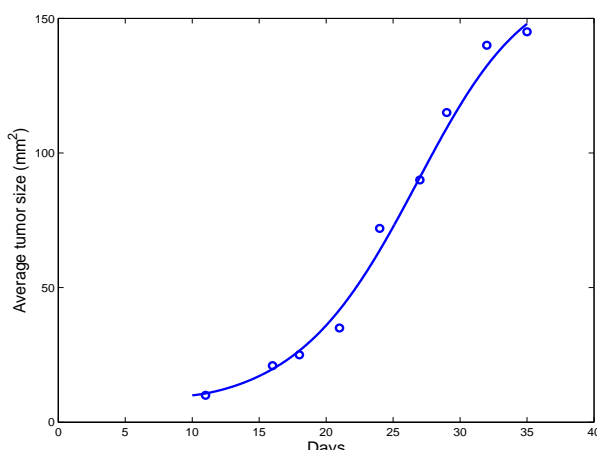

t (days)	$S(t)$ mm^2	$S'(t)$ mm^2/day
15	18	2.38
20	36	5.43
25	72	8.93
30		
35	148	4.00

Exercise 10.4.5 a. Let $y = \arctan x$ so that $x = \tan y(x)$. Show that

$$\sec^2 y(x) = 1 + x^2.$$

b. Use $x = \tan y(x)$ and the chain rule, $[G(u(x))]' = G'(u(x)) u'(x)$, to conclude that

$$1 = (\sec^2 y(x)) y'(x) \quad \text{and} \quad y'(x) = \frac{1}{1 + x^2}.$$

c. Use the result of b. to show that

$$\int_0^1 \frac{1}{1 + x^2} dx = \frac{\pi}{4}$$

10.5 Integral Formulas.

Because the problem, “Find $F(t)$ such that $F'(t) = f(t)$ ” occurs with each application of the Fundamental Theorem of Calculus II, extensive tabulations of solutions to the problem (called **antiderivatives** or **indefinite integrals**) have been made during the 300 years since calculus was first introduced. I. S. Grdsteyn and I. W. Ryzhik list some 2000 - 2500 antiderivatives in their “Table of Integrals Series and Products”, Academic Press, 1965. More recently, computer programs have been written that provide a rich supply of antiderivatives (Mathematica, Derive, Maple, MATLAB) and some hand held calculators will solve most of the commonly encountered problems. The antiderivatives are denoted by

$$\int f(t) dt$$

and are called **indefinite integrals** because the interval of integration is not specified (there are no lower and upper limits of integration). Because the derivative of a constant function is zero, every indefinite integral is really a set of functions, each two members of which differ by a constant. The common notation always includes an additive constant in the solution. For example,

$$\int x^2 dx = \frac{x^3}{3} + C \tag{10.7}$$

is read, ‘the indefinite integral of x^2 is $\frac{x^3}{3} + C$ ’ where it is understood that C is a constant. The implication is that every function whose derivative is x^2 is of the form, $\frac{x^3}{3} + C$.

For every derivative formula, there is an indefinite integral (antiderivative) formula. There follows a table of indefinite integral formulas corresponding to the derivative formulas on page 390.

$$\int 0 dt = C \quad (10.8) \qquad \int e^t dt = e^t + C \quad (10.11)$$

$$\int 1 dt = t + C \quad (10.9) \qquad \int \frac{1}{t} dt = \ln t + C \quad (10.12)$$

$$\int t^n dt = \frac{t^{n+1}}{n+1} + C \quad \text{for } n \neq -1 \quad (10.10) \qquad \int \sin t dt = -\cos t + C \quad (10.13)$$

$$\int \cos t dt = \sin t + C \quad (10.14)$$

$$\int K P(t) dt = K \int P(t) dt \quad (10.15)$$

$$\int [f(t) + g(t)] dt = \int f(t) dt + \int g(t) dt \quad (10.16)$$

$$\int [f'(t) g(t) + f(t) g'(t)] dt = f(t) g(t) + C \quad (10.17)$$

$$\int G'[u(t)] u'(t) dt = G[u(t)] + C \quad (10.18)$$

$$\int [u(t)]^n u'(t) dt = \frac{u(t)^{n+1}}{n+1} + C \quad \text{for } n \neq 0 \quad (10.19)$$

$$\int e^{u(t)} u'(t) dt = e^{u(t)} + C \quad (10.20)$$

$$\int \frac{1}{u(t)} u'(t) dt = \ln|u(t)| + C \quad (10.21)$$

$$\int \sin u(t) u'(t) dt = -\cos u(t) + C \quad (10.22)$$

$$\int \cos u(t) u'(t) dt = \sin u(t) + C \quad (10.23)$$

$$\int e^{kt} dt = \frac{1}{k} e^{kt} + C \quad (10.24)$$

An easy aspect of antiderivative formulas is that they can be checked readily by differentiation. For example, Equation 10.10 asserts that all functions whose derivative is t^n are of the form $\frac{t^{n+1}}{n+1} + C$. We can check that all such functions have t^n as their derivative:

$$\frac{d}{dt} \left[\frac{t^{n+1}}{n+1} + C \right] = \frac{d}{dt} \left[\frac{t^{n+1}}{n+1} \right] + \frac{d}{dt} [C] \quad \text{Equation 3.30}$$

$$= \frac{1}{n+1} \frac{d}{dt} [t^{n+1}] + \frac{d}{dt} [C] \quad \text{Equation 3.29}$$

$$= \frac{1}{n+1} \frac{d}{dt} [t^{n+1}] + 0 \quad \text{Equation 3.27}$$

$$= \frac{1}{n+1} (n+1)t^n + 0 \quad \text{Equation 3.29}$$

$$= t^n.$$

That there are no other such functions is a consequence of the Parallel Graph Theorem.

The indefinite integral formulas enable computation of antiderivatives of all polynomials; in

fact, only four of the antiderivative formulas are needed. For example

$$\int [5t^7 - 3t^4 + 2] dt = \int [5t^7] dt - \int [3t^4] dt + \int 2 dt \quad \text{Equation 10.16}$$

$$= 5 \int t^7 dt - 3 \int t^4 dt + 2 \int 1 dt \quad \text{Equation 10.15}$$

$$= 5 \left[\frac{t^8}{8} + C_1 \right] - 3 \left[\frac{t^5}{5} + C_2 \right] + 2 \int 1 dt \quad \text{Equation 10.10}$$

$$= 5 \left[\frac{t^8}{8} + C_1 \right] - 3 \left[\frac{t^5}{5} + C_2 \right] + 2[t + C_3] \quad \text{Equation 10.9}$$

$$= \frac{5}{8}t^8 - \frac{3}{5}t^5 + 2t + C.$$

The constant terms included in the antiderivatives are usually suppressed until the last step, and are treated as rather pliable objects. For example, C in the last equation above is $5C_1 - 3C_2 + 2C_3$. Because a linear combination of constants is just a constant, and because subscripts are a nuisance, one often sees algebraic steps that would imply

$$5C - 3C + 2C = C.$$

Students usually adapt to this murky algebra without suffering serious damage, but it seems only fair to warn you of this practice, as we will follow it subsequently.

10.5.1 Using the chain rules.

Equations 10.18 through 10.23 are all consequences of a chain rule for derivatives and always when using one of these equations it is important to identify $u(t)$, $G'(u)$, $u'(t)$ and $G(u)$.

Example 10.5.1 Two antiderivative problems that appear similar,

$$\int e^{(t^2)} dt \quad \text{and} \quad \int e^{(t^2)} t dt$$

are peculiarly different. The first has no expression in familiar terms. The second is easy.

In the second equation, identify

$$u(t) = t^2, \quad G'(u) = e^u, \quad u'(t) = 2t \quad \text{and} \quad G(u) = e^u$$

Then

$$\begin{aligned} \int e^{(t^2)} t dt &= \int \frac{1}{2} e^{(t^2)} 2 t dt && \text{Arithmetic} \\ &= \frac{1}{2} \int e^{(t^2)} (2 t) dt && \text{Equation 10.15} \\ &= \frac{1}{2} \int e^{u(t)} u'(t) dt \\ &= \frac{1}{2} e^{u(t)} + C && \text{Equation 10.20} \\ &= \frac{1}{2} e^{(t^2)} + C && \blacksquare \end{aligned}$$

Example 10.5.2 Consider solving the two problems

$$\int (1 + t^4)^{10} t^3 dt \quad \text{or} \quad \int (1 + t^4)^{10} t^2 dt$$

Because $(1 + t^4)^{10}$ can be expanded by multiplication (using either the binomial expansion formula or by making nine multiplications) and the expanded form is a polynomial, both integrands of these two problems are polynomials and the antiderivatives of polynomials can be easily computed. The first integral can be solved without expansion, however, and is easier to compute.

Identify

$$u(t) = 1 + t^4, \quad G'(u) = u^{10}, \quad u'(t) = 4t^3 \quad \text{and} \quad G(u) = \frac{u^{11}}{11}$$

Then

$$\begin{aligned} \int (1 + t^4)^{10} t^3 dt &= \int \frac{1}{4} (1 + t^4)^{10} 4 t^3 dt && \text{Arithmetic} \\ &= \frac{1}{4} \int (1 + t^4)^{10} (4 t^3) dt && \text{Equation 10.15} \\ &= \frac{1}{4} \int (u(t))^{10} u'(t) dt && \text{Substitution} \\ &= \frac{1}{4} \frac{(u(t))^{11}}{11} + C && \text{Equation 10.19} \\ &= \frac{1}{4} \frac{(1 + t^4)^{11}}{11} + C && u(t) = 1 + t^4 \end{aligned}$$

Students sometimes attempt to solve $\int (1 + t^4)^{10} t^2 dt$ by the following means. They are thinking of

$$\begin{aligned} u(t) = 1 + t^4, \quad G'(u) = u^{10}, \quad u'(t) = 4t^3 \quad \text{and} \quad G(u) = \frac{u^{11}}{11} \\ \int (1 + t^4)^{10} t^2 dt &= \int \frac{1}{4t} (1 + t^4)^{10} 4t^3 dt && \text{Algebra} \\ &= \frac{1}{4t} \int (1 + t^4)^{10} 4t^3 dt && \text{UGH!} \end{aligned}$$

The last step is incorrect because $\frac{1}{4t}$ is not a constant. The corresponding step in the previous argument is correct because $\frac{1}{4}$ is a constant and Equation 10.15 asserts that $\int K f(t) dt = K \int f(t) dt$ when K is a constant. It is incorrect when K is not constant. ■

Example 10.5.3 Compute $\int \sin(\pi t) dt$. Identify

$$u(t) = \pi t, \quad G'(u) = \sin u, \quad u'(t) = \pi \quad \text{and} \quad G(u) = -\cos u$$

Then

$$\begin{aligned} \int \sin(\pi t) dt &= \int \frac{1}{\pi} \sin(\pi t) \pi dt = \frac{1}{\pi} \int \sin(\pi t) \pi dt = \\ \frac{1}{\pi} \int \sin(u(t)) u'(t) dt &= \frac{1}{\pi} (-\cos(u(t))) + C = -\frac{1}{\pi} (\cos(\pi t)) + C \quad \blacksquare \end{aligned}$$

Example 10.5.4 Compute $\int \sqrt{5t - 4} dt$. Identify

$$u(t) = 5t - 4, \quad G'(u) = \sqrt{u} = (u)^{1/2}, \quad u'(t) = 5 \quad \text{and} \quad G(u) = \frac{u^{3/2}}{3/2}$$

Then

$$\begin{aligned} \int \sqrt{5t-4} dt &= \frac{1}{5} \int \sqrt{5t-4} 5 dt = \frac{1}{5} \int (u(t))^{1/2} u'(t) dt = \frac{1}{5} \frac{(u(t))^{3/2}}{3/2} + C \\ &= -\frac{2}{15} (5t-4)^{3/2} + C \quad \blacksquare \end{aligned}$$

Example 10.5.5 Compute $\int (\ln t)^3 \frac{1}{t} dt$. Identify

$$u(t) = \ln t, \quad G'(u) = u^3, \quad u'(t) = \frac{1}{t} \quad \text{and} \quad G(u) = \frac{u^4}{4}$$

Then

$$\int (\ln t)^3 \frac{1}{t} dt = \int (u(t))^3 u'(t) dt = \frac{(u(t))^4}{4} + C = \frac{(\ln t)^4}{4} + C \quad \blacksquare$$

Example 10.5.6 Compute $\int \tan x dx$. This is a good one. First write

$$\int \tan x dx = \int \frac{\sin x}{\cos x} dx$$

Then identify

$$u(x) = \cos x, \quad G'(u) = \frac{1}{u}, \quad u'(x) = -\sin x \quad \text{and} \quad G(u) = \ln u$$

Then

$$\begin{aligned} \int \tan x &= \int \frac{\sin x}{\cos x} dx = -\int \frac{1}{\cos x} (-\sin x) dx = -\int \frac{1}{u(x)} u'(x) dx \\ &= -\ln u(x) + C = -\ln \cos x + C = \ln \sec x + C \quad \blacksquare \end{aligned}$$

Always, once an antiderivative has been computed, it can be checked by differentiation.

We check the last claim that $\int \tan x = \ln \sec x + C$ by differentiation. We should show that $[\ln \sec x]' = \tan x$.

$$[\ln \sec x]' = \frac{1}{\sec x} [\sec x]' = \frac{1}{\sec x} \sec x \tan x = \tan x$$

10.5.2 Integration by parts.

Equation 10.17

$$\int [f'(t) g(t) + f(t) g'(t)] dt = f(t) g(t) + C$$

may be rewritten as

$$\int f(t) g'(t) dt = f(t) g(t) - \int f'(t) g(t) dt \quad (10.25)$$

Equation 10.25 exchanges the problem, $\int f(t) g'(t) dt$ for the problem $\int f'(t) g(t) dt$. There are times when that is a good trade, but some cleverness is required to recognize when a good trade is

possible. The process is called integration by parts, $f(t)$ and $g'(t)$ being the parts in the first integral and $f'(t)$ and $g(t)$ being the parts in the second integral.

In computing $\int t \sin t \, dt$, there is a good trade. Identify

$$\begin{aligned} f(t) &= t & \text{and} & & g'(t) &= \sin t \\ f'(t) &= 1 & & & g(t) &= -\cos t \end{aligned}$$

Then

$$\begin{aligned} \int t \sin t \, dt &= t(-\cos t) - \int 1(-\cos t) \, dt \\ &= -t \cos t + \sin t + C \end{aligned}$$

In computing $\int t^2 \sin t \, dt$, two good trades can be made. First we identify

$$\begin{aligned} f(t) &= t^2 & \text{and} & & g'(t) &= \sin t \\ f'(t) &= 2t & & & g(t) &= -\cos t \end{aligned}$$

Then

$$\int t^2 \sin t \, dt = t^2(-\cos t) - \int 2t(-\cos t) \, dt$$

Next we identify

$$\begin{aligned} f(t) &= 2t & \text{and} & & g'(t) &= -\cos t \\ f'(t) &= 2 & & & g(t) &= -\sin t \end{aligned}$$

and write

$$\begin{aligned} \int t^2 \sin t \, dt &= t^2(-\cos t) - \int 2t(-\cos t) \, dt \\ &= t^2(-\cos t) - (2t(-\sin t) - \int 2(-\sin t) \, dt) \\ &= t^2(-\cos t) - 2t(-\sin t) + \int 2(-\sin t) \, dt \\ &= t^2(-\cos t) - 2t(-\sin t) + 2(\cos t) + C \end{aligned}$$

A chart to keep track of these computations is shown in Figure 10.5. You may see from the chart or an expansion of it how to compute $\int t^2 \cos t \, dt$ and $\int t^3 \sin t \, dt$ and $\int t^3 e^t \, dt$.

Exercises for Section 10.5, Integral Formulas.

Exercise 10.5.1 Use your technology to find a fourth degree polynomial close to the data in the table below taken from the graph of average solar intensity at Eugene, Oregon in Figure 9.1.3 on page 405.

Day	1	60	120	180	240	300	360
Day minus 180	-179	-120	-60	0	60	120	180
Solar intensity, kw-hr/m ²	1.0	2.0	4.5	6.7	5.6	1.8	1.0

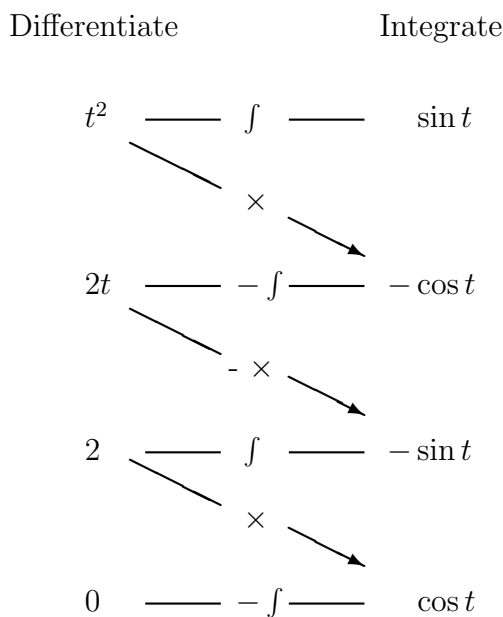

Figure 10.5: Chart for computing the terms for integration by parts.

Your technology will object that the equations to compute the coefficients of a fourth degree polynomial to the Day - Solar Intensity data are ill conditioned (subject to roundoff error); the equations to fit Day minus 180 - Solar Intensity are OK. Therefore, fit a fourth degree polynomial to the Day minus 180 - Solar Intensity data, and interpret the polynomial according for plotting the data and for integration. You should get

$$P(t) = 8.7339 \cdot 10^{-9}(t - 180)^4 - 1.2225 \cdot 10^{-7}(t - 180)^3 - 4.5587 \cdot 10^{-4}(t - 180)^2 + 3.4149 \cdot 10^{-3}(t - 180) + 6.63072$$

- a. Plot the data and a graph of your polynomial.
- b. Compute the integral of $\int_0^{365} P_2(t) dt$.
- c. Compare your answers to the estimate of 1324 computed using the trapezoid rule on 12 intervals of length 30 and one interval of length 5, in Exercise 9.1.3 on page 404.

Exercise 10.5.2 Check by differentiation the validity of the indefinite integral formulas:

a. $\int \frac{1}{t} dt = \ln t + C$ b. $\int [U(t)]^n U'(t) dt = \frac{U(t)^{n+1}}{n+1} + C$ c. $\int e^{kt} dt = \frac{1}{k}e^{kt} + C$

Exercise 10.5.3 Compute $\int (1 + t^4)^3 dt$.

Exercise 10.5.4 Which of the two indefinite integrals

$$\int \frac{1}{1+t^2} t dt \quad \text{or} \quad \int \frac{1}{1+t^2} dt$$

is $\ln(1 + t^2)^{0.5} + C$? Explain your answer. Note: The other indefinite integral is $\arctan t + C$.

Exercise 10.5.5 Compute the following integrals and antiderivatives. For the definite integrals, draw a region in the plane whose area is computed by the integral. If you solve the integral by a substitution, $u(t) =$, then identify in writing $u(t)$ and $u'(t)$.

$$\begin{array}{lll}
 a. \int_0^1 t^4 dt & b. \int_0^1 t^{499} dt & c. \int_0^1 t^{1/2} dt \\
 d. \int_0^2 e^x dx & e. \int_0^\pi \cos z dz & f. \int_2^6 \frac{1}{y} dy \\
 g. \int_{12}^{36} \frac{1}{t} dt & h. \int t^{-1/2} dt & i. \int (\sin t + \cos t) dt \\
 j. \int \sqrt{t} dt & k. \int (5t^4 + 3t^2 + 5) dt & l. \int \frac{w^2+w+1}{w} dw
 \end{array}$$

Exercise 10.5.6 Compute the following antiderivatives or integrals. If you solve the integral by a substitution, $u(t) =$, then identify in writing $u(t)$ and $u'(t)$.

$$\begin{array}{lll}
 a. \int e^{2t} dt & b. \int \sin(2t) 2 dt & c. \int \frac{1}{\sqrt{t}} dt \\
 d. \int 3z^{-1} dz & e. \int (3 \cos z + 4 \sin z) dz & f. \int (\pi^2 + e^2) dz \\
 g. \int \frac{x^2}{\sqrt{x}} dx & h. \int \frac{x^2+1}{x} dx & i. \int \left(x + \frac{1}{x}\right)^2 dx \\
 j. \int \frac{1}{t+1} dt & k. \int (1+t^2)^3 2t dt & l. \int \frac{1}{z^5} dz
 \end{array}$$

Exercise 10.5.7 Compute the following antiderivatives. If you solve the integral by a substitution, $u(t) =$, then identify in writing $u(t)$ and $u'(t)$.

$$\begin{array}{lll}
 a. \int \sin^4(t) \cos t dt & b. \int t(1+t^2)^3 dt & c. \int \frac{1}{(z+1)^3} dz \\
 d. \int \frac{1}{4t+1} dt & e. \int t(1+t^4)^3 dt & f. \int \frac{1}{3z+1} dz \\
 g. \int \frac{\sin t}{\cos t} dt & h. \int (1+x)^3 dx & i. \int \frac{z}{z^2+1} dz \\
 j. \int (1+t^2)^3 t^{-1} dt & k. \int e^{2+z} dz & l. \int_0^\pi \sin(\pi+x) dx \\
 m. \int \sin(4t) dt & n. \int (\ln x) \frac{1}{x} dx & o. \int e^{-z^2} z dz
 \end{array}$$

Exercise 10.5.8

$$\begin{array}{ll}
 a. \text{ (a) Compute } [x \ln x - x]' & b. \text{ Note: } \sin^2 \theta = \frac{1 - \cos 2\theta}{2} \\
 \text{ (b) Compute } \int_1^e \ln x dx & \text{ Compute } \int_0^\pi \sin^2 \theta d\theta \\
 c. \text{ (a) Show that } \frac{1}{t} + \frac{1}{1-t} = \frac{1}{t(1-t)} & d. \text{ (a) Believe: } [\arcsin x]' = \frac{1}{\sqrt{1-x^2}} \\
 \text{ (b) Compute } \int \frac{1}{t(1-t)} dt & \text{ (b) Compute } \int_0^{1/2} \frac{1}{\sqrt{1-x^2}} dx
 \end{array}$$

Exercise 10.5.9 Solve using integration by parts, $\int u(x)v'(x) dx = u(x)v(x) - \int v(x)u'(x) dx$ (or $\int u dv = uv - \int v du$).

$$\begin{array}{llll} \text{a. } \int xe^x dx & \text{b. } \int x \ln x dx & \text{c. } \int x \sin x dx & \text{d. } \int x^2 e^x dx \\ \text{e. } \int xe^{2x} dx & \text{f. } \int \ln x \cdot 1 dx & \text{g. } \int x \cos x dx & \text{h. } \int x^3 e^{x^2} dx \end{array}$$

Exercise 10.5.10 a. Use integration by parts on $\int e^x \sin x dx$, with $u(x) = e^x$ and $v'(x) = \sin x$, to show that

$$\int e^x \sin x dx = -e^x \cos x + \int e^x \cos x dx.$$

Use a second step integration by parts on $\int e^x \cos x dx$ to show that

$$\int e^x \cos x dx = e^x \sin x - \int e^x \sin x dx$$

Combine the previous two equations to show that

$$\int e^x \sin x dx = \frac{1}{2}e^x(\sin x - \cos x) + C$$

b. Do two steps of integration by parts on

$$\int e^x \cos x dx \quad \text{and show that} \quad \int e^x \cos x dx = \frac{1}{2}e^x(\sin x + \cos x) + C$$

c. Do two steps of integration by parts on

$$\int (\sin x) e^{-x} dx \quad \text{and show that} \quad \int_0^\pi e^{-x} \sin x dx = \frac{1}{2}(e^{-\pi} + 1)$$

d. **Clever!** Note that $\int e^{\sqrt{x}} dx = \int 2\sqrt{x} e^{\sqrt{x}} \frac{1}{2\sqrt{x}} dx$.

Let $u = 2\sqrt{x}$ and $v' = e^{\sqrt{x}} \frac{1}{2\sqrt{x}}$ and show that

$$\int e^{\sqrt{x}} dx = 2\sqrt{x} e^{\sqrt{x}} - 2e^{\sqrt{x}} + C$$

Chapter 11

Applications of the Fundamental Theorem of Calculus and Multiple Integrals.

Where are we going?

Several of the traditional applications of the Fundamental Theorem of Calculus and a definition of integrals of functions of two variables are included in this chapter.

The Fundamental Theorem of Calculus II, symbolically written

$$\int_a^b F'(t) dt = F(b) - F(a) = [F(t)]_a^b = F(t) \Big|_a^b, \quad (11.1)$$

replaces tedious computations of the limit of sums of rectangular areas with an often easier problem of finding an antiderivative. The theorem is widely applied in physics and chemistry and engineering. It is useful in biology, but less widely so because the integrands, $f(t)$, often are not expressed as elementary functions. Indeed, the integrands in biology may be only partly specified as tables of data, in which case the options are to (1) compute a rectangular or trapezoidal sum or (2) approximate the data with an elementary function (a polynomial, for example) and compute the integral of the elementary function using Equation 11.1.

11.1 Volume.

Example 11.1.1 *How to find the volume of a potato.*

A potato is pictured in Figure 11.1A with marks along an axis at 2 cm intervals. A cross section of the potato at position 10 cm showing an area of approximately 17 cm^2 is pictured in Figure 11.1B. The volume of the slice between stations 8 cm and 10 cm is approximately $2 \text{ cm} \times 17 \text{ cm}^2 = 34 \text{ cm}^3$. There are 9 slices, and the volume of the potato is approximately

$$\sum_{k=1}^9 (\text{Area of slice } k \text{ in } \text{cm}^2) \times 2 \text{ cm}.$$

The approximation works remarkably well. Several students have computed approximate volumes and subsequently tested the volumes with liquid displacement in a beaker and found close agreement.

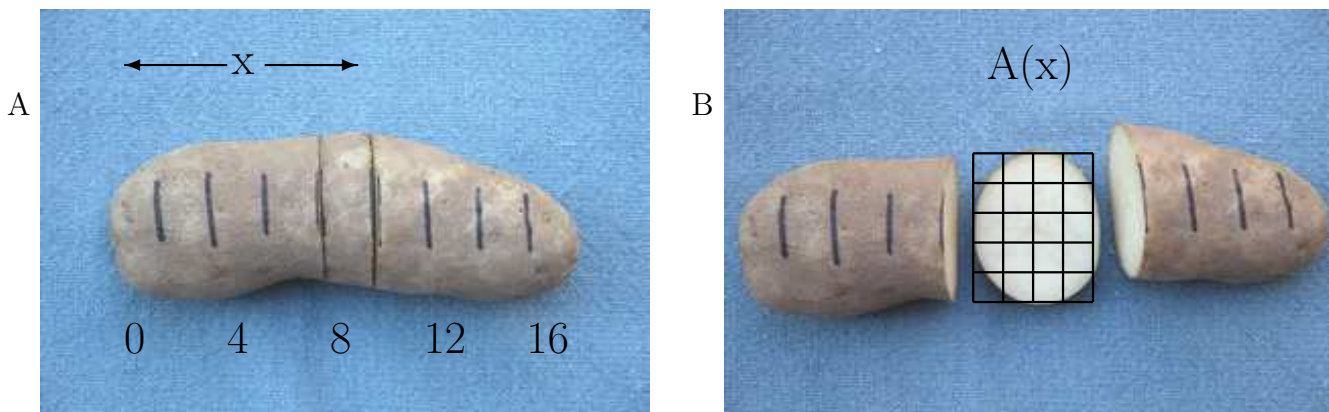

Figure 11.1: A. A potato with 2 cm marks along an axis. B. A slice of the potato at position $x = 10$ that has area approximately 17 cm^2 .

The sum is also an approximation to the integral

$$\int_0^{17} A(x) dx,$$

where $A(x)$ is the area of the cross section of the potato at station x , and the integral may be considered to be the actual volume. ■

The principle applies to any three dimensional region, R . Assume there is an axis L and for each station x between stations a and b along the axis, the area $A(x)$ of the cross section of R perpendicular to L at x is known. If $\Delta = [x_0, x_2, x_2 \cdots x_{n-1}, x_n]$ is a partition of $[a, b]$. Then

$$\begin{aligned} \text{Volume of } R &\doteq \sum_{k=1}^n A(x_k) (x_k - x_{k-1}) \\ &\longrightarrow \int_a^b A(x) dx \quad \text{as } |\Delta| \rightarrow 0. \end{aligned} \tag{11.2}$$

Using this procedure, volumes of a large number of regions can be computed.

Example 11.1.2 The volume of a sphere. Consider a sphere with radius R and center at the origin of three dimensional space. We will compute the volume of the hemisphere between $x = 0$ and $x = R$. See Figure 11.2A. Suppose x is between 0 and R . The cross section of the region at x is a circle of radius r and area πr^2 . Therefore

$$r^2 + x^2 = R^2, \quad r^2 = R^2 - x^2 \quad \text{and} \quad A = A(x) = \pi(R^2 - x^2).$$

Consequently the volume of the hemisphere is

$$V = \int_0^R \pi(R^2 - x^2) dx$$

The indefinite integral is the antiderivative of a polynomial, and

$$\int \pi(R^2 - x^2) dx = \int (\pi R^2 - \pi x^2) dx = \pi R^2 x - \pi \frac{x^3}{3} + C.$$

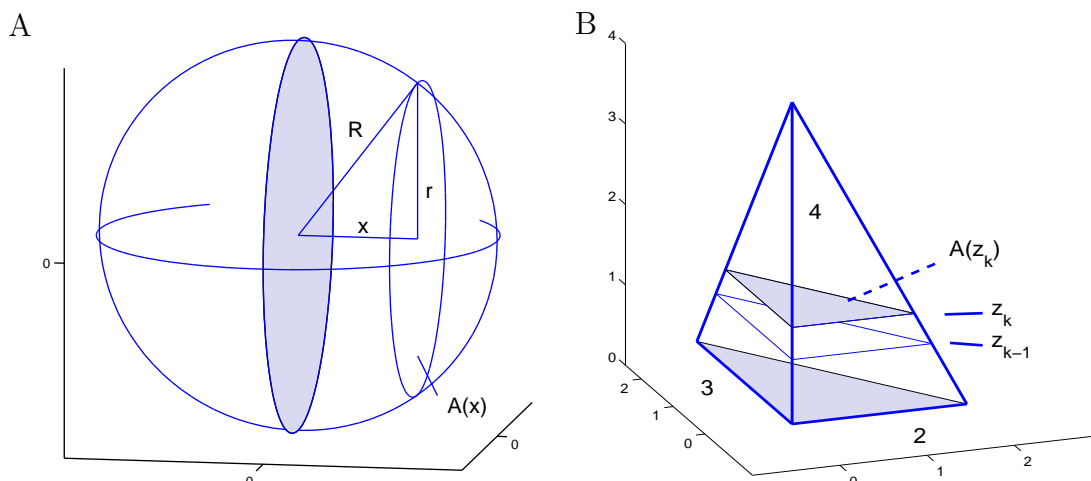

Figure 11.2: A. A sphere of radius R . The cross section a distance x from the center of the sphere is a circle of radius $r = \sqrt{R^2 - x^2}$. B. A triangular solid; the edges of lengths 2, 3, and 4 are mutually perpendicular.

By the Fundamental Theorem of Calculus II,

$$V = \int_0^R \pi(R^2 - x^2) dx = \left[\pi R^2 x - \pi \frac{x^3}{3} \right]_0^R = \left(\pi R^2 \times R - \pi \frac{R^3}{3} \right) - \left(\pi R^2 \times 0 - \pi \frac{0^3}{3} \right) = \frac{2}{3} \pi R^3.$$

The volume of the sphere is twice the volume of the hemisphere.

The volume of a sphere of radius R is $\frac{4}{3} \pi R^3$

This formula was known to Archimedes and perhaps to mathematicians who preceded him, and is easily computed using Equation 11.2. Archimedes and his work are fascinating; a short description of them can be found at www.uz.ac.zw/science/math/zimaths/33/archimed.htm. and a longer description is in <http://en.wikipedia.org/wiki/Archimedes>. ■

Example 11.1.3 Compute the volume of the triangular solid with three mutually perpendicular edges of length 2, 3, and 4, illustrated in Figure 11.2B.

At height z , the cross section is a right triangle with sides x and y and the area $A(z) = \frac{1}{2} x \times y$. Now

$$\frac{x}{2} = \frac{4-z}{4} \quad \text{so} \quad x = \frac{2}{4}(4-z). \quad \text{Similarly,} \quad y = \frac{3}{4}(4-z).$$

Therefore

$$A(z) = \frac{1}{2} \frac{2}{4}(4-z) \frac{3}{4}(4-z) = \frac{3}{16}(4-z)^2,$$

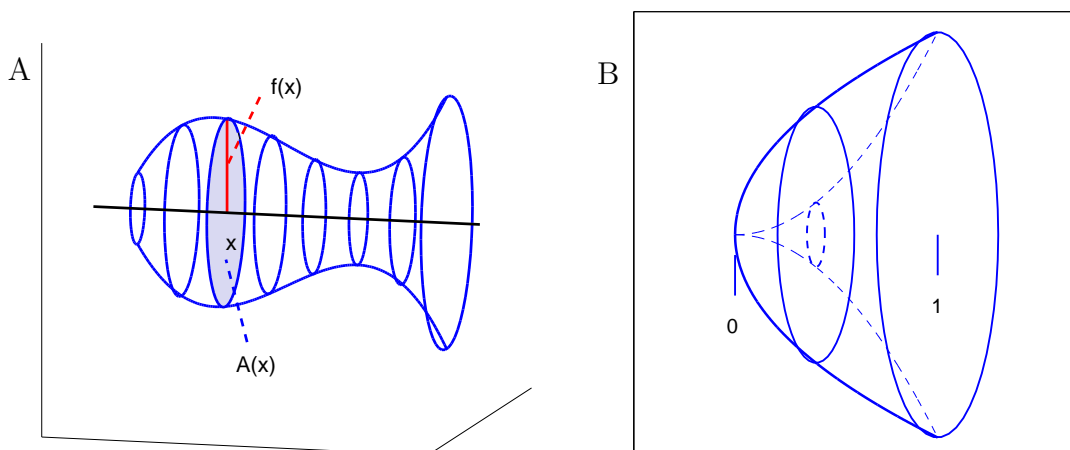

Figure 11.3: A. A solid of revolution. A cross section at station x is a circle with radius $f(x)$ and has area $A(x) = \pi (f(x))^2$. B. Solid generated by rotating the region between $y = x^2$ (dashed curve) and $y = \sqrt{x}$ about the x -axis.

and

$$V = \int_0^4 A(z) dz = \int_0^4 \frac{3}{16} (4 - z)^2 dz = \frac{3}{16} \int_0^4 (4 - z)^2 dz.$$

Check that $\left[-\frac{(4 - z)^3}{3} \right]' = (4 - z)^2$. Then

$$\frac{3}{16} \int_0^4 (4 - z)^2 dz = \frac{3}{16} \left[-\frac{(4 - z)^3}{3} \right]_0^4 = \frac{3}{16} (-0 - (-\frac{(4)^3}{3})) = 4. \quad \blacksquare$$

Example 11.1.4 *Volume of a solid of revolution.* Equation 11.2 is particularly simple for solids of revolution. A solid of revolution for non-negative function f is shown in Figure 11.3A. The cross section at station x is a circle of radius $f(x)$ and has area $A(x) = \pi (f(x))^2$. From Equation 11.2 the volume is

$$\text{Volume of a solid of revolution} = \int_a^b A(x) dx = \int_a^b \pi (f(x))^2 dx \quad (11.3)$$

Problem. Find the volume of the solid S generated by rotating the region R between $y = x^2$ and $y = \sqrt{x}$ about the x -axis. See Figure 11.3B.

Solution. There are two problems here. First we compute the volume of the solid, S_1 , generated by rotating the region below $y = \sqrt{x}$, $0 \leq x \leq 1$, about the x -axis. Then we subtract the volume of the solid, S_2 , generated by rotating $y = x^2$, $0 \leq x \leq 1$ about the x -axis.

$$\text{Volume of } S_1 \quad \int_0^1 \pi (\sqrt{x})^2 dx = \pi \int_0^1 x dx = \pi \left[\frac{x^2}{2} \right]_0^1 = \frac{\pi}{2}$$

$$\text{Volume of } S_2 \quad \int_0^1 \pi (x^2)^2 dx = \pi \int_0^1 x^4 dx = \pi \left[\frac{x^5}{5} \right]_0^1 = \frac{\pi}{5}$$

$$\text{Volume of } S \quad \frac{\pi}{2} - \frac{\pi}{5} = \frac{3\pi}{10}$$

Alternatively, we can compute the area of the 'washer' at x which is

$$A(x) = \pi (\sqrt{x})^2 - \pi (x^2)^2 = \pi (x - x^4).$$

Then

$$\text{Volume of } S = \int_0^1 \pi (x - x^4)^2 dx = \pi \left[\frac{x^2}{2} - \frac{x^5}{5} \right]_0^1 = \pi \left(\frac{1}{2} - \frac{1}{5} \right) = \frac{3\pi}{10} \blacksquare$$

Exercises for Section 11.1, Volume

Exercise 11.1.1 Data for all of the slices of the potato shown in Figure 11.1 are:

Slice Position (cm)	2	4	6	8	10	12	14	16
Slice Area (cm ²)	11	15	14	16	17	15	13	10

Approximate the volume of the potato.

Exercise 11.1.2 The Visible Human Project at the National Institutes of Health has provided numerous images of cross sections of the human body. They are being integrated into the medical education and research community through a program based at the University of Michigan. Shown in Exercise Figure 11.1.2 are eight cross sections of the right side of the female brain. Your job is to estimate the volume of the brain. Assume that the sections are at 1 cm separation, that the first section only shows brain membrane, and that the scale of the cross sections is 1:4. Include only the brain and not the membrane which is apparent as white tissue. We found it useful to make a 5mm grid on clear plastic (the cover of a CD box), each square of which would be equivalent to 4 cm². The average human brain volume is 1450 cm³.

Figure for Exercise 11.1.2 Cross sections of the right side of the human skull. Initial figures were downloaded from <http://vhp.med.umich.edu/browsers/female.html> of the University of Michigan Medical School.

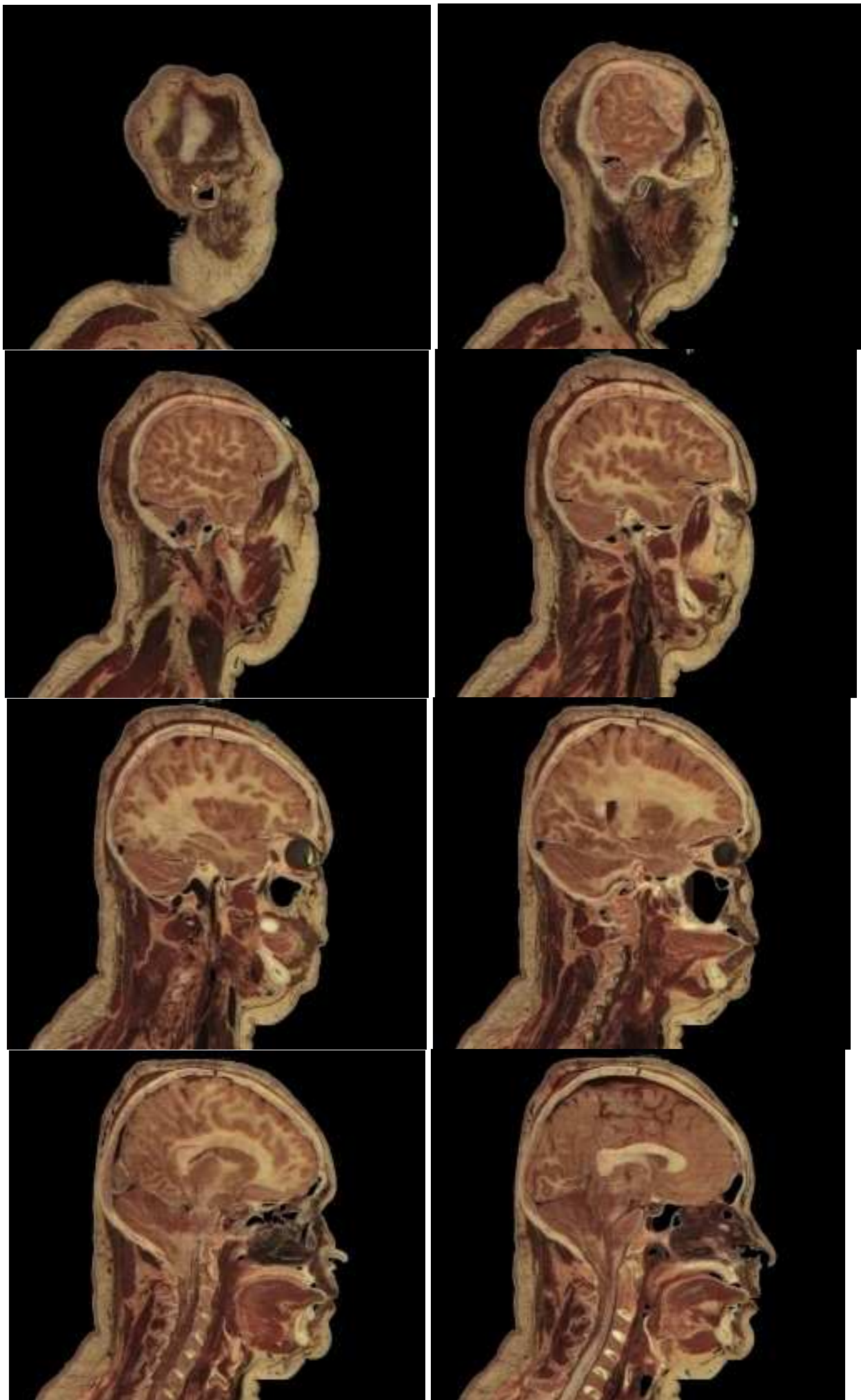

Exercise 11.1.3 a. Write an integral that is the volume of the body with base the region of the x,y -plane bounded by

$$y_1 = 0.25 \sqrt{x} \sqrt[4]{2-x} \quad y_2 = -0.25 \sqrt{x} \sqrt[4]{2-x} \quad 0 \leq x \leq 2$$

and with each cross section perpendicular to the x -axis at x being a square with lower edge having endpoints $[x, y_2(x), 0]$ and $[x, y_1(x), 0]$ (see Exercise Figure 11.1.5A). (The value of the integral is $4\sqrt{2}/15$).

b. Write an integral that is the volume of the body with base the region of the x,y -plane bounded by

$$y_1 = 0.25 \sqrt{x} \sqrt[4]{2-x} \quad y_2 = -0.25 \sqrt{x} \sqrt[4]{2-x} \quad 0 \leq x \leq 2,$$

and with each cross section perpendicular to the x -axis at x being an equilateral triangle with lower edge having endpoints $[x, y_2(x), 0]$ and $[x, y_1(x), 0]$ (see Exercise Figure 11.1.5B). (The value of the integral is $\sqrt{6}/15$).

Figure for Exercise 11.1.3 Graphs for Exercise 11.1.3 The dashed lines are the lower edges of the squares in A and triangles in B.

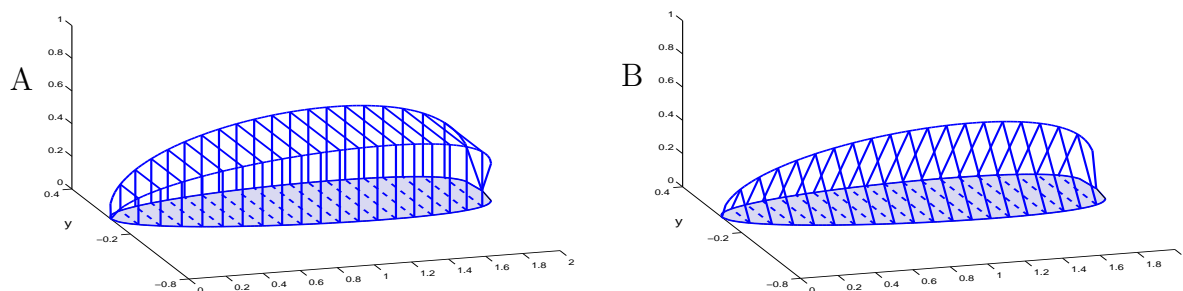

Exercise 11.1.4 An artist friend observes that the bodies in Figure 11.1.3 are boring and adds some pizzaz by curving the central axis with a function, $w(x)$. Thus the base is bounded by

$$y_1 = w(x) + 0.25 \sqrt{x} \sqrt[4]{2-x} \quad y_2 = w(x) - 0.25 \sqrt{x} \sqrt[4]{2-x} \quad 0 \leq x \leq 2.$$

The modified bodies are shown in Figure 11.1.4. The squares and triangles are translations of the squares and triangles in Figure 11.1.3.

- Write an integral that is the volume of the body in Figure 11.1.4A.
- Write an integral that is the volume of the body in Figure 11.1.4B.

Figure for Exercise 11.1.4 Graphs for Exercise 11.1.4

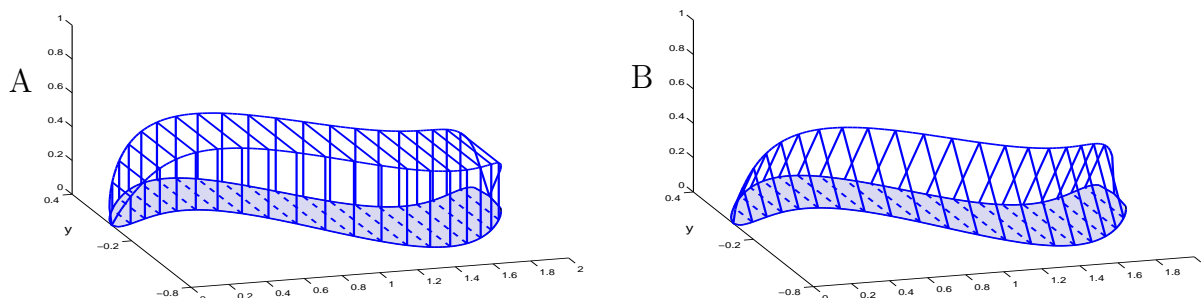

Exercise 11.1.5 The base of the bodies in Figure 11.1.5 are bounded by

$$y_1 = x^2(2 - x) \quad y_2 = -x^2(2 - x) \quad 0 \leq x \leq 2.$$

Squares and equilateral triangles perpendicular to the axes are drawn with their lower edges spanning the base.

- Write an integral that is the volume of the body in Figure 11.1.5A.
- Write an integral that is the volume of the body in Figure 11.1.5B.

Figure for Exercise 11.1.5 Graphs for Exercise 11.1.5

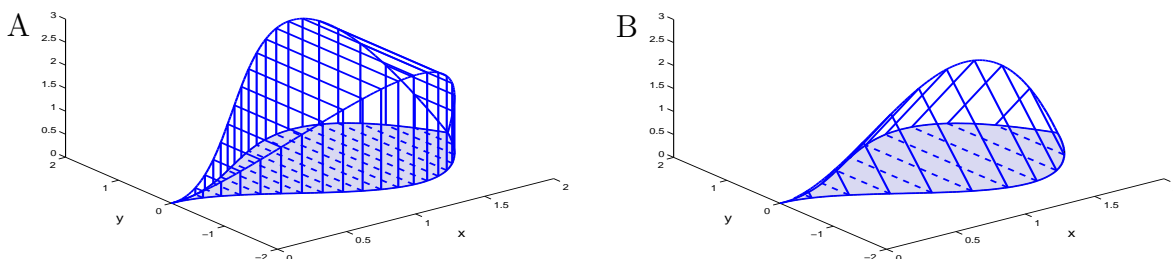

Exercise 11.1.6 The base of the body in Figure 11.1.5 is bounded by

$$y_1 = \sqrt{1 - x^2} \quad y_2 = -\sqrt{1 - x^2} \quad -1 \leq x \leq 1.$$

Rectangles perpendicular to the axes are drawn with their lower edges spanning the base. The height of the rectangle at x is $\sqrt{1 - x^2}$. Write and evaluate an integral that is the volume of the body in Figure 11.1.6.

Figure for Exercise 11.1.6 Graph for Exercise 11.1.6

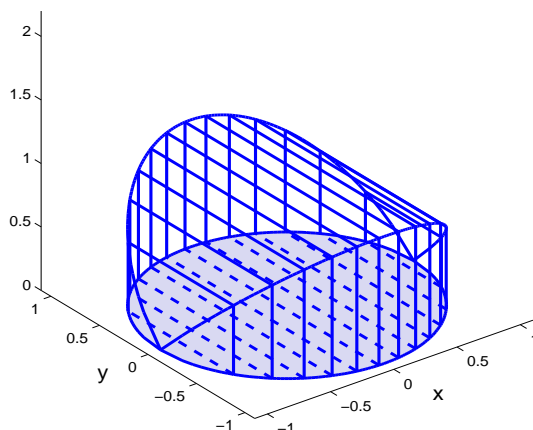

Exercise 11.1.7 Find the volume of the right circular cone with base radius R and height H .

Exercise 11.1.8 The pyramid of Cheops, the largest of the Egyptian pyramids, is 146.6 meters tall with a square base of side 230.4 meters. What is its volume?

Figure for Exercise 11.1.8 Schematic diagram of the Pyramid of Cheops, Exercise 11.1.8

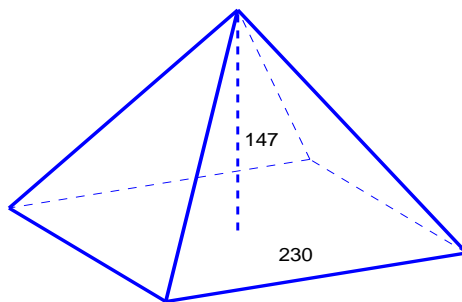

Exercise 11.1.9 Write as the difference of two integrals the volume of the torus (doughnut) obtained by rotating the region inside the circle $x^2 + (y - b)^2 = a^2$ ($0 < a < b$) about the x -axis.

Exercise 11.1.10 Atmospheric density at altitude h meters is approximately $1.225e^{-0.000101h}$ kg/m³ for $0 \leq h \leq 5000$ meters. Compute the mass of air in a vertical one-square meter column between 0 and 5000 meters.

11.2 Change the variable of integration.

If $x = g(z)$, define $dx = g'(z) dz$ and write

$$\int f(x) dx = \int f(g(z)) g'(z) dz \tag{11.4}$$

If $a = g(c)$ and $b = g(d)$, then

$$\int_a^b f(x) dx = \int_c^d f(g(z)) g'(z) dz \tag{11.5}$$

Example 11.2.1 For the integration problem,

$$\int \sqrt{1 + \sqrt{x}} dx \quad \text{substitute} \quad x = g(z) = z^2, \quad \text{and} \quad dx = g'(z) dz = 2z dz.$$

Then compute

$$\begin{aligned} \int \sqrt{1 + \sqrt{z^2}} 2z; dz &= \int \sqrt{1 + z} 2z dz \\ &= \int \sqrt{1 + z} (2z + 2 - 2) dz \\ &= 2 \int (1 + z)^{3/2} - (1 + z)^{1/2} dz \\ &= 2 \left(\frac{(1 + z)^{5/2}}{5/2} - \frac{(1 + z)^{3/2}}{3/2} \right) + C. \end{aligned}$$

One can remember that $x = z^2$, and assume $z = \sqrt{x}$ and write

$$\int \sqrt{1 + \sqrt{x}} dx = 2 \left(\frac{(1 + \sqrt{x})^{5/2}}{5/2} - \frac{(1 + \sqrt{x})^{3/2}}{3/2} \right) + C. \quad (11.6)$$

Explore 11.2.1 Check the validity of Equation 11.6. ■

For $\int_0^4 \sqrt{1 + \sqrt{x}} dx$, and $g(z) = z^2$, $g(0) = 0$, and $g(2) = 4$.

$$\begin{aligned} \int_0^4 \sqrt{1 + \sqrt{x}} dx &= \int_0^2 \sqrt{1 + \sqrt{z^2}} 2z dz \\ &= 2 \left[\frac{(1 + z)^{5/2}}{5/2} - \frac{(1 + z)^{3/2}}{3/2} \right]_0^2 \doteq 6.075895918 \quad \blacksquare \end{aligned}$$

Proof of Change of Variables Equation 11.5. Equation 11.5 is derived from the Chain Rule for derivatives and the Fundamental Theorem of Calculus. Assume f is continuous and g has a continuous derivative and $g(c) = a$ and $g(d) = b$. Suppose F and G satisfy

$$F'(x) = f(x) \quad \text{and} \quad G'(z) = F(g(z)).$$

Then $G'(z) = F'(g(z)) g'(z) = f(g(z)) g'(z)$, and

$$\int_c^d f(g(z)) g'(z) dz = \int_c^d G'(z) dz = G(d) - G(c) = F(b) - F(a) = \int_a^b f(x) dx$$

End of proof.

Example 11.2.2 Problem. Compute $\int \sqrt{1 + x^2} dx$.

Solution. Let $x = \tan z$. Then $dx = \sec^2 z dz$. Compute

$$\begin{aligned} \int \sqrt{1 + \tan^2 z} \sec^2 z dz &= \\ \int \sec^3 z dz &= \int (\sec z) (1 + \tan^2 z) dz \\ &= \int \frac{(\sec z) (\sec z + \tan z)}{\sec z + \tan z} + \left(\int \tan z \sec z \tan z dz \right) \\ &\qquad\qquad\qquad u = \tan z, \quad v' = \sec z \tan z \\ &= \int \frac{\sec^2 z + \sec z \tan z}{\tan z + \sec z} dz + \left(\sec z \tan z - \int \sec z \sec^2 z dz \right) \\ &= \ln(\tan z + \sec z) + \sec z \tan z - \int \sec^3 z dz \\ 2 \int \sec^3 z dz &= \ln(\tan z + \sec z) + \sec z \tan z + C \\ \int \sqrt{1 + x^2} dx &= \frac{1}{2} \left(\ln(x + \sqrt{1 + x^2}) + x \sqrt{1 + x^2} \right) + C \end{aligned}$$

The following triangle helps translate from z back to x .

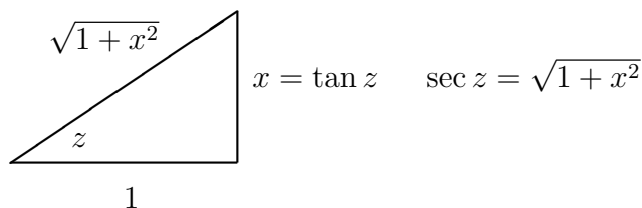

Example 11.2.3 *Bacteria.* A micrograph of rod-shaped bacilli is shown in Figure 11.4A. The solid, S , obtained by rotating the graph of $y = b\sqrt[4]{x}\sqrt[4]{a-x}$, shown in Figure 11.4B reasonably approximates the shape of the bacilli. We compute the volume, V , of S .

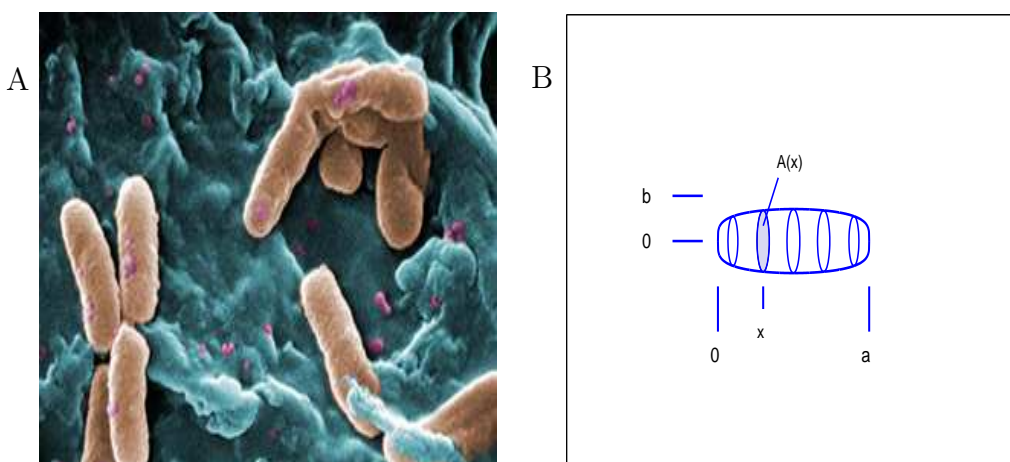

Figure 11.4: Rod-shaped bacilli; it *Pseudomonas aeruginosa* provided to Wikipedia Commons by Janice Haney Carr of the Centers for Disease Control and Public Health’s Public Image Library. B. The graph of $y = b\sqrt[4]{x}\sqrt[4]{a-x}$. The solid obtained by rotating the graph about the x -axis approximates the body of the bacilli.

$$\begin{aligned}
 V &= \int_0^a \pi \left(b\sqrt[4]{x}\sqrt[4]{a-x} \right)^2 dx \\
 &= \pi b^2 \int_0^a \sqrt{x}\sqrt{a-x} dx
 \end{aligned}$$

Let $x = az$; then $dx = adz$ and $x = 0$ and $x = a$ correspond to $z = 0$ and $z = 1$. Then

$$V = \pi b^2 \int_0^1 \sqrt{az} \sqrt{a-az} adz = \pi b^2 a^2 \int_0^1 \sqrt{z} \sqrt{1-z} dz$$

The skies darken and lightning abounds.

$$\int \sqrt{z} \sqrt{1-z} dz = \frac{1}{4} \arcsin \sqrt{z} - \frac{1}{4} \sqrt{z} \sqrt{1-z} (1-2z) + C \tag{11.7}$$

Then

$$\begin{aligned}
 V &= \pi b^2 \frac{a^2}{4} \left[\arcsin \sqrt{z} - \sqrt{z} \sqrt{1-z} (1-2z) \right]_0^1 \\
 &= a^2 b^2 \frac{\pi^2}{8}
 \end{aligned}$$

Equation 11.7 may be found in a **table of integrals** and is derived using substitution and Equation 11.4.

Problem. Find $\int \sqrt{z} \sqrt{1-z} dz$.

Solution. Let $z = \sin^2 \theta$. Then $dz = [\sin^2 \theta]' d\theta = 2 \sin \theta \cos \theta d\theta$.

$$\begin{aligned} \int \sqrt{z} \sqrt{1-z} dz &= \int \sqrt{\sin^2 \theta} \sqrt{1 - \sin^2 \theta} \times 2 \sin \theta \cos \theta d\theta = \\ 2 \int \sin^2 \theta \cos^2 \theta d\theta &= \frac{1}{4} \int (1 - \cos 4\theta) d\theta = \frac{1}{4} \left(\theta - \frac{1}{4} \sin 4\theta \right) + C \\ &= \frac{1}{4} \left(\theta - (\sin \theta \cos \theta)(1 - 2 \sin^2 \theta) \right) + C \\ &= \frac{1}{4} \arcsin \sqrt{z} - \frac{1}{4} \sqrt{z} \sqrt{1-z}(1 - 2z) + C \end{aligned}$$

The following triangle helps translate from θ to z .

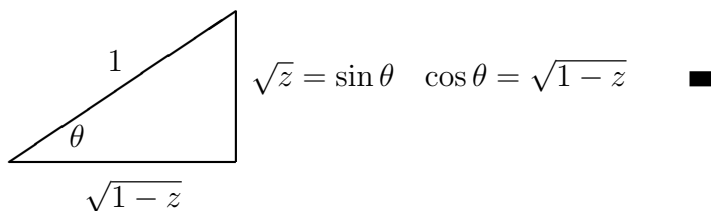

Exercises for Section 11.2, Change the variable of integration.

Exercise 11.2.1 Use the suggested substitutions to compute the antiderivatives. Also, use technology or look up the integrals in a table of integrals.

- | | |
|--|--|
| a. $\int \frac{1}{\sqrt{1-x^2}} dx \quad x = \sin z$ | b. $\int \frac{1}{1+x^2} dx \quad x = \tan z$ |
| c. $\int \frac{1}{\sqrt{1+x^2}} dx \quad x = \tan z$ | d. $\int \frac{x}{\sqrt{1+x}} dx \quad x = z - 1$ |
| e. $\int \sqrt{1-x^2} dx \quad x = \sin z$ | f. $\int \frac{1}{\sqrt{x^2-1}} dx \quad x = \sec z$ |
| g. $\int \frac{1}{1+\sqrt{x}} dx \quad x = z^2$ | h. $\int \frac{1-\sqrt{x}}{1+\sqrt{x}} dx \quad x = z^2$ |

11.3 Center of mass.

Center of mass is an important concept to students of biomechanics, the study of the movement of animals including walking, running, skating, diving. For an ice skater who performs a jump, the

path of her center of mass will be a parabola. The center of mass of a walker moves up and down with each stride, thus expending energy; the minimum energy per distance traveled is expended when walking approximately 3 mph¹. In walking the center of mass reaches its highest point at the center of the stance (when the two feet are together) and in running the center of mass reaches its lowest point at the center of the stance².

Explore 11.3.1 Through what point of a potato might you push a slender rod so that the potato would be balanced on that rod? ■

If a collection of masses m_1, m_2, \dots, m_n is distributed at positions x_1, x_2, \dots, x_n along a rod (of negligible mass) and c is a point of the rod, then the *moment* of the masses about c is

$$\text{Moment} = m_1(x_1 - c) + m_2(x_2 - c) + \dots + m_{n-1}(x_{n-1} - c) + m_n(x_n - c) \tag{11.8}$$

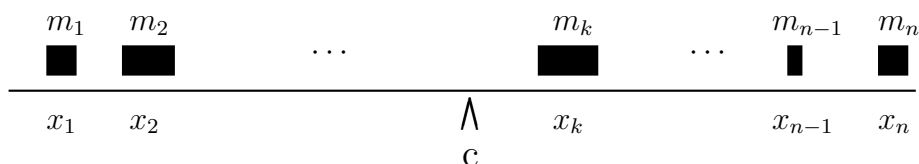

The value of c for which the moment is zero is the center of mass of the system. We write the moment from Equation 11.8 equal to zero and solve for c .

$$\begin{aligned} \sum_{k=1}^n m_k(x_k - c) &= 0 \\ \sum_{k=1}^n m_k x_k - \sum_{k=1}^n m_k c &= \sum_{k=1}^n m_k x_k - c \sum_{k=1}^n m_k = 0 \\ c &= \frac{\sum_{k=1}^n m_k x_k}{\sum_{k=1}^n m_k} \end{aligned}$$

Assume a mass is distributed in a region R and that the density of the mass varies along an axis L as $\delta(x)$ for $a \leq x \leq b$. Assume also that the area of the cross section of R perpendicular to L at x is $A(x)$ and c is a station on L . Then the moment of the mass about c is

$$\text{Moment of mass} = \int_a^b (x - c)\delta(x)A(x) dx. \tag{11.9}$$

The value of c for which the moment is zero is

$$c = \frac{\int_a^b x\delta(x)A(x) dx}{\int_a^b \delta(x)A(x) dx}. \tag{11.10}$$

¹T. F. Novocheck, *Gait and Posture*, 7 (1998), 77-95

²C. R. Lee and C. T. Farley, *J. of Experimental. Biol.*, 201 (1998), 2935-2944

The number c in Equation 11.10 is called the center of mass of the system.

If $\delta(x) = \delta$, a constant, then

$$c = \frac{\int_a^b x \delta A(x) dx}{\int_a^b \delta A(x) dx} = \frac{\delta \int_a^b x A(x) dx}{\delta \int_a^b A(x) dx} = \frac{\int_a^b x A(x) dx}{\int_a^b A(x) dx}, \quad (11.11)$$

and c is called the centroid of the region R .

Example 11.3.1 Problem. Compute the centroid of the right circular cone of height H and base radius R . See Figure 11.5

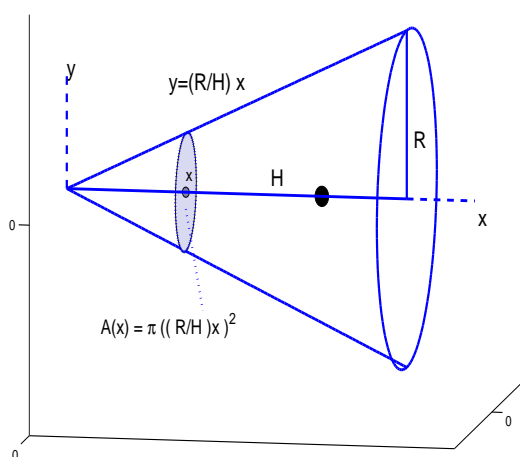

Figure 11.5: Centroid of a right circular cone of height H and base radius R . The conical axis lies on the X -axis.

Solution. We picture the cone as the solid of revolution obtained by rotating the graph of $y = (R/H) \times x$, $0 \leq x \leq H$ about the X -axis. Then $A(x) = \pi \times ((R/H) x)^2$ and the centroid c is computed from Equation 11.11 as

$$c = \frac{\int_0^H x \pi \times ((R/H) x)^2 dx}{\int_0^H \pi \times ((R/H) x)^2 dx} = \frac{\int_0^H x^3 dx}{\int_0^H x^2 dx} = \frac{H^4/4}{H^3/3} = \frac{3}{4}H$$

The centroid, c , is $3/4$ the distance from the vertex of the cone and $1/4$ the distance from the base of the cone. ■

Example 11.3.2 Problem. Suppose a horizontal flat plate of thickness 1 and uniform density has a horizontal outline bounded by the graph of $y = x^2$, $y = 1$, and $x = 4$. Where is the centroid of the plate. See Figure 11.6.

Solution. There are two problems here. The first is, 'What is the x -coordinate, \bar{x} , of the centroid'; the second is, 'What is the y -coordinate, \bar{y} , of the centroid?' The z -coordinate of the centroid is one-half the thickness, $\bar{z} = 1/2$.

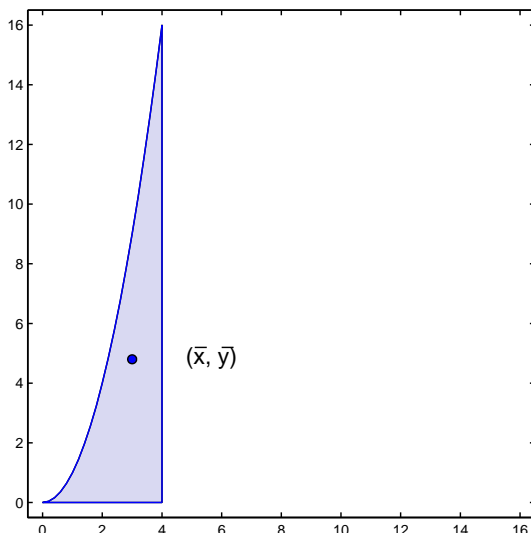

Figure 11.6: Centroid of a horizontal flat plate bounded by the graphs of $y = x^2$, $y = 0$, and $x = 4$.

For the x -coordinate of the centroid, the cross sectional area of the region in a plane perpendicular to the X -axis at a position x is $x^2 \times 1 = x^2$ for $0 \leq x \leq 4$. We write

$$\bar{x} = \frac{\int_0^4 x \times x^2 dx}{\int_0^4 x^2 dx} = \frac{\int_0^4 x^3 dx}{\int_0^4 x^2 dx} = \frac{4^4/4}{4^3/3} = 3$$

For the y -coordinate of the centroid, the cross sectional area of the region in a plane perpendicular to the Y -axis at a position y is $(1 - \sqrt{y}) \times 1 = 1 - \sqrt{y}$ for $0 \leq y \leq 16$. We write

$$\bar{y} = \frac{\int_0^{16} y \times (1 - \sqrt{y}) dy}{\int_0^4 1 - \sqrt{y} dy} = \frac{\int_0^{16} y - y^{3/2} dx}{\int_0^{16} 1 - y^{1/2} dx} = \frac{[y^2/2 - y^{5/2}/(5/2)]_0^{16}}{[y - y^{3/2}/(3/2)]_0^{16}} = \frac{24}{5} \blacksquare$$

Example 11.3.3 Problem. Consider a hemispherical region generated by rotating the graph of $y = \sqrt{1 - x^2}$, $0 \leq x \leq 1$ about the x axis that is filled with a substance that has density, $\delta(x)$, equal to x . Find the center of mass of the substance.

Solution. At position x , the radius of the cross section perpendicular to the X -axis is $\sqrt{1 - x^2}$, the area of the cross section is $\pi(1 - x^2)$. From Equation 11.10, the

$$\begin{aligned} \text{Center of mass} &= \frac{\int_a^b x\delta(x)A(x) dx}{\int_a^b \delta(x)A(x) dx} = \frac{\int_0^1 x \times x \times \pi(1 - x^2) dx}{\int_0^1 x \times \pi(1 - x^2) dx} \\ &= \frac{\int_0^1 x^2 - x^4 dx}{\int_0^1 x - x^3 dx} = \frac{[x^3/3 - x^5/5]_0^1}{[x^2/2 - x^4/4]_0^1} = \frac{8}{15} \blacksquare \end{aligned}$$

Exercises for Section 11.3, Center of Mass

Exercise 11.3.1 Find approximately the horizontal coordinate of the center of mass of the potato shown in Figure 11.1 using the data

Slice Position (cm)	2	4	6	8	10	12	14	16
Slice Area (cm ²)	11	15	14	16	17	15	13	10

The next two problems require evaluation of some integrals. You may find your calculator or MATLAB useful. The Texas Instrument calculator command "fnInt" is useful. To integrate $3 * x^{1.5} - x^{2.5}$ from $x = 2$ to $x = 3$, for example, you would push 2nd calc and find fnInt. Then write `fnInt(3*x^(1.5)-x^(2.5),x,2,3)`.

Or you may use MATLAB. Write an m-file, say, myfun6.m

```
function y = myfun6(x)
y=3*x.^1.5 - x.^2.5;
```

Then issue the command, `Q = quad(@myfun6,2,3)`

Exercise 11.3.2 Find the x -coordinate of the centroids of the areas:

- The triangle with vertices $(0,0)$, $(2,0)$ and $(2,1)$; $0 \leq x \leq 2$, $0 \leq y \leq 0.5 * x$.
- The semicircle, $0 \leq x \leq 1$, $-\sqrt{1-x^2} \leq y \leq \sqrt{1-x^2}$.
- The parabolic segment, $0 \leq x \leq 1$, $-\sqrt{x} \leq y \leq \sqrt{x}$.
- The parallelogram with vertices $(0,0)$, $(1,1)$, $(3,1)$, and $(2,0)$.

Exercise 11.3.3 For 1 cm thick plates that have plans in the x - y plane described below, suppose the the density at position x is $2 * \sqrt{x}$. Find the x -coordinates of the centers of mass of the objects. If there is an integral for which you can not find an appropriate antiderivative, use your technology or approximate the integral using 10 subintervals of the interval of integration.

- The triangle with vertices $(0,0)$, $(2,0)$ and $(2,1)$; $0 \leq x \leq 2$, $0 \leq y \leq 0.5 * x$.
- The semicircle, $0 \leq x \leq 1$, $-\sqrt{1-x^2} \leq y \leq \sqrt{1-x^2}$.
- The parabolic segment, $0 \leq x \leq 1$, $-\sqrt{x} \leq y \leq \sqrt{x}$.
- The parallelogram with vertices $(0,0)$, $(1,1)$, $(3,1)$, and $(2,0)$. **Danger: Evaluation of the six integrals by hand without error is highly improbable. You should write the integrals and accept our answer: 1.6531.**

Exercise 11.3.4 Find the centroid of that portion of the sagittal section of the skull shown in Exercise Figure 11.3.4 that lies above a line connecting the two circles. Scale of the figure is 1:4.

Figure for Exercise 11.3.4 Sagittal section of a human skull at 1:4 scale, Exercise 11.3.4.

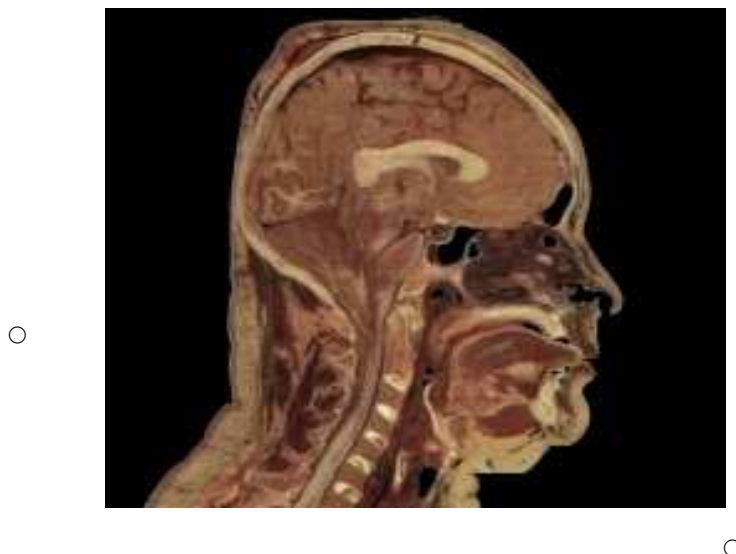

11.4 Arc length and Surface Area.

Arc Length.

Consider the problem of finding the length of the graph of $y = f(x)$ shown in Figure 11.7.

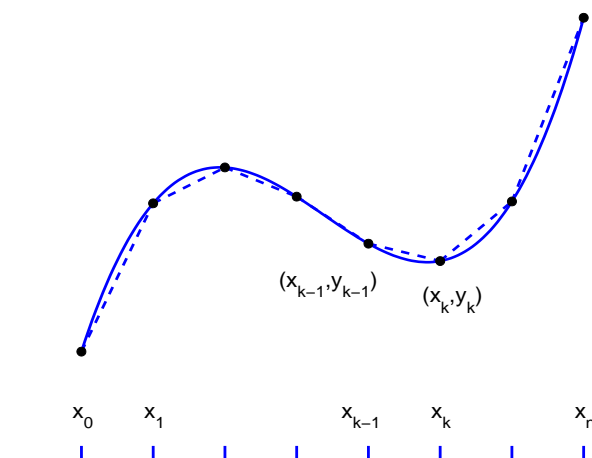

Figure 11.7: Graph of a function, f , and a polygon that approximates it.

We partition the interval $[a, b]$ into $a = x_0 < x_1 < \dots < x_{k-1} < x_k < \dots < x_n = b$. Then the length of f is approximately

$$\begin{aligned} \text{Length} &\doteq \sum_{k=1}^n \sqrt{(x_k - x_{k-1})^2 + (f(x_k) - f(x_{k-1}))^2} \\ &= \sum_{k=1}^n \sqrt{1 + \left(\frac{f(x_k) - f(x_{k-1})}{x_k - x_{k-1}}\right)^2} (x_k - x_{k-1}) \end{aligned}$$

By the Mean Value Theorem, for each k there is a number c_k between x_{k-1} and x_k such that

$$\frac{f(x_k) - f(x_{k-1})}{x_k - x_{k-1}} = f'(c_k).$$

Then

$$\text{Length} \doteq \sum_{k=1}^n \sqrt{1 + (f'(c_k))^2} (x_k - x_{k-1})$$

This pattern fits Definition 9.4.4, Definition of Integral II, and

$$\sum_{k=1}^n \sqrt{1 + (f'(c_k))^2} (x_k - x_{k-1}) \doteq \int_a^b \sqrt{1 + (f'(x))^2} dx$$

Both approximations converge as the norm of the partition decreases to zero and we write

$$\text{Length of the graph of } f \text{ is } \int_a^b \sqrt{1 + (f'(x))^2} dx \tag{11.12}$$

Equation 11.12 is excellent in concept but difficult in practice in that there are not many functions f for which an antiderivative $\int \sqrt{1 + (f'(t))^2} dt$ can be found. One function for which the antiderivative can be found is $y = \ln \cos x$.

Example 11.4.1 Problem. Find the length of the graph of $y = \ln \cos x$ on $0 \leq x \leq \pi/4$.

We write

$$f(x) = \ln \cos x \quad f'(x) = [\ln \cos x]' \quad \frac{1}{\cos x} [\cos x]' = \frac{1}{\cos x} (-\cos x) = -\tan x$$

We leave it to you to check that **Bolt out of the Blue**

$$[\ln(\sec x + \tan x)]' = \sec x$$

We can write

$$\begin{aligned} \text{Length} &= \int_0^{\pi/4} \sqrt{1 + (f'(x))^2} dx = \int_0^{\pi/4} \sqrt{1 + \tan^2 x} dx = \int_0^{\pi/4} \sec x dx \\ &= [\ln(\sec x + \tan x)]_0^{\pi/4} \\ &= \ln(\sec(\pi/4) + \tan(\pi/4)) - \ln(\sec(0) + \tan(0)) \doteq 0.881 \quad \blacksquare \end{aligned}$$

Surface Area. The surface area to volume ratio limits the size of cells. The surface areas of the lungs and the small intestine determines, respectively, the oxygen absorbance and nutrient absorbance in humans.

We will compute surface areas only for surfaces of revolution. We use the fact that the surface area of the frustum of a cone (illustrated in Figure 11.8A) is

$$\text{Area of frustum of a cone} = \pi(r_1 + r_2) s_1$$

The proof is left to you, and you may be assisted by Figure 11.8B in which the frustum has been cut along a slant side and flattened. The angle $\theta = 2\pi r_1/(s_1 + s_2) = 2\pi r_2/s_2$.

Shown in Figure 11.9 is a surface of revolution and a section between x_{k-1} and x_k . The area of that frustum is

$$\begin{aligned} A_k &= \pi(f(x_{k-1}) + f(x_k)) \sqrt{(x_k - x_{k-1})^2 + (f(x_k) - f(x_{k-1}))^2} \\ &= \pi(f(x_{k-1}) + f(x_k)) \sqrt{1 + \left(\frac{f(x_k) - f(x_{k-1})}{x_k - x_{k-1}}\right)^2} (x_k - x_{k-1}) \end{aligned}$$

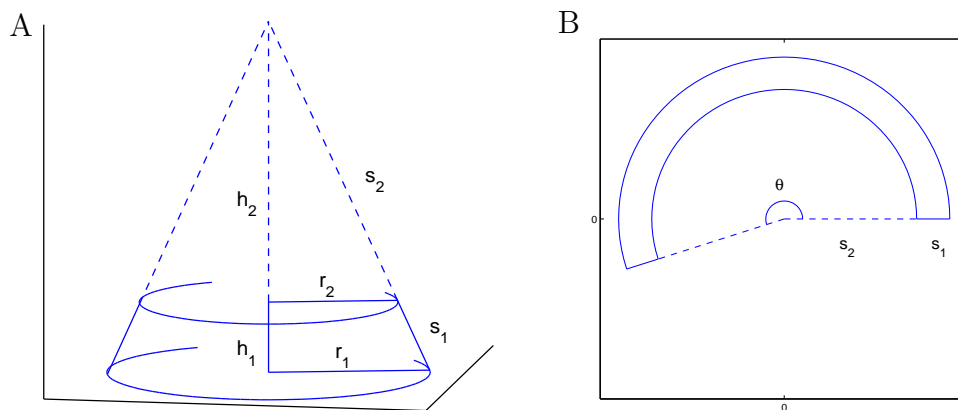

Figure 11.8: A. The frustum of a cone; r_1 , r_2 , and h_1 determine the cone. B. The same frustum flattened onto a plane. The angle $\theta = 2\pi r_1 / (s_1 + s_2) = 2\pi r_2 / s_2$.

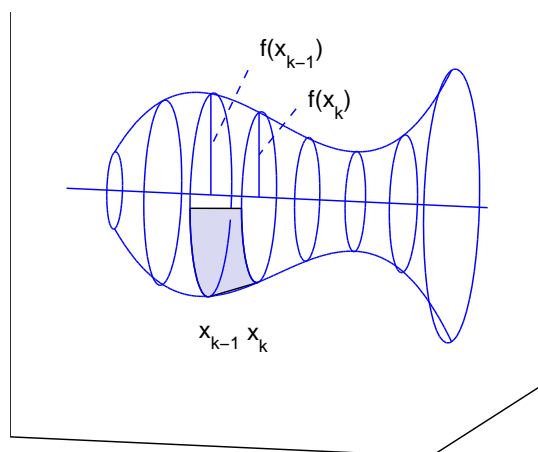

Figure 11.9: A surface of revolution with approximating conical frustum.

By the Mean Value Theorem there is a number, c_k between x_{k-1} and x_k such that

$$\frac{f(x_k) - f(x_{k-1})}{x_k - x_{k-1}} = f'(c_k).$$

The area of the surface of revolution is approximately $\sum_{k=1}^n A_k$ so that

$$\text{Surface Area} \doteq \pi(f(x_{k-1}) + f(x_k))\sqrt{1 + (f'(c_k))^2}(x_k - x_{k-1})$$

Because x_{k-1} , c_k and x_k may all three be different, we appeal to an even more general definition of the integral than Definition of the Integral II and conclude that this approximating sum converges to $\int_a^b \pi(f(x) + f(x))\sqrt{1 + (f'(x))^2} dx$. as the norm of the partition goes to zero. Therefore we write

$$\text{Surface Area} = \int_a^b 2\pi f(x)\sqrt{1 + (f'(x))^2} dx \tag{11.13}$$

Again the collection of functions f for which an antiderivative $\int 2\pi f(x)\sqrt{1+(f'(x))^2} dx$ can be found is small. Fortunately one such function is $f(x) = \sqrt{R^2 - x^2}$ and the surface area is that of a sphere, $4\pi R^2$, which appears in Exercise 11.4.4.

Exercises for Section 11.4, Arc Length and Surface Area.

Exercise 11.4.1 Find the length of the graph of $f(x) = \frac{3}{2}x^{2/3}$, $1 \leq x \leq 8$. Note: In order to evaluate the integral, use a substitution, $u(x) = x^{2/3} + 1$, $u'(x) = \frac{2}{3}x^{-1/3}$.

Exercise 11.4.2 Write an integral that is the length of the curve

$$y = \frac{e^x + e^{-x}}{2} \quad -1 \leq x \leq 1.$$

Show that the integral is $\int_{-1}^1 y(x) dx$ and evaluate it.

The graph of y is the shape of a cable suspended between the points $(-1, y(-1))$ and $(1, y(1))$ and is called a *catenary*.

Exercise 11.4.3 a. Find the length of the spine illustrated in Figure 11.4.3.

b. The spinal chord begins at the occipital bone and extends to the space between the first and second lumbar vertebrae. Find, approximately, the length of the spinal chord.

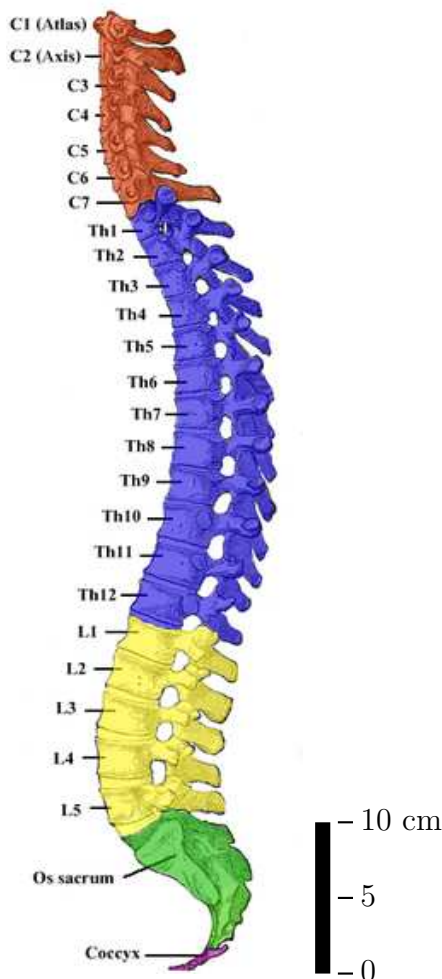

Figure for Exercise 11.4.3

Spinal Chord. This is a figure from Gray’s Anatomy, colored and put into the public domain by Uwe Gille. See http://en.wikipedia.org/wiki/Spinal_chord.

Exercise 11.4.4 Use Equation 11.13 and $f(x) = \sqrt{R^2 - x^2}$ to find the surface area of a sphere of radius R . Archimedes knew this to be $4\pi R^2$. He first guessed the answer based on the common knowledge among basket weavers that the bowl of a hemispherical basket required twice as much material as its top, which has area πr^2 .

Exercise 11.4.5 Find the area of the surface generated by rotating the graph of $y = 2\sqrt{x}$, $0 \leq x \leq 1$ about the x -axis.

Exercise 11.4.6 How much glaze on a doughnut? Write as a sum of two integrals the surface area of the torus (doughnut) generated by rotating the circle $x^2 + (y - b)^2 = a^2$ ($0 < a < b$) about the x -axis. Note: The surface area is $4ab\pi^2$.

11.5 The improper integral, $\int_a^\infty f(t) dt$.

In this section we give examples of problems for which a reasonable answer is of the form

$$\lim_{R \rightarrow \infty} \int_a^R f(t) dt \quad \text{which is denoted by} \quad \int_a^\infty f(t) dt \quad (11.14)$$

This is called an 'improper' integral, but there is nothing improper about it.

Another integral

$$\int_0^1 \frac{1}{\sqrt{x}} dx,$$

is also said to be improper. The integrand, $\frac{1}{\sqrt{x}}$ has an identity crisis at $x = 0$; the integrand is not defined at $x = 0$ and is unbounded in every interval $[0, r]$, $r > 0$. The integrand is continuous on every interval $(r, 1]$, $r > 0$, however, and

$$\int_0^1 \frac{1}{\sqrt{x}} dx \quad \text{is defined to be} \quad \lim_{r \rightarrow 0^+} \int_r^1 \frac{1}{\sqrt{x}} dx = \lim_{r \rightarrow 0^+} [2\sqrt{x}]_r^1 = 2.$$

Example 11.5.1 Problem. Is there an initial vertical speed of a satellite that is sufficient to insure that it will escape the Earth's gravity field without further propulsion?

Solution. The work done along an axis against a variable force $F(x)$ is

$$W = \int_a^b F(x) dx$$

The acceleration of gravity at an altitude x is given as

$$g(x) = 9.8 \times \frac{R^2}{(R+x)^2} \quad \text{meters/sec}^2$$

where $R = 6370$ meters is the radius of Earth. This means a satellite of mass m and altitude x experiences a gravitational force of

$$F(x) = m \times 9.8 \times \frac{R^2}{(R+x)^2} \quad \text{Newtons}$$

The work required to lift the satellite to an altitude A is

$$W(A) = \int_0^A m \times 9.8 \times \frac{R^2}{(R+x)^2} dx = 9.8 \times m \times R^2 \int_0^A \frac{1}{(R+x)^2} dx$$

The integral is readily evaluated.

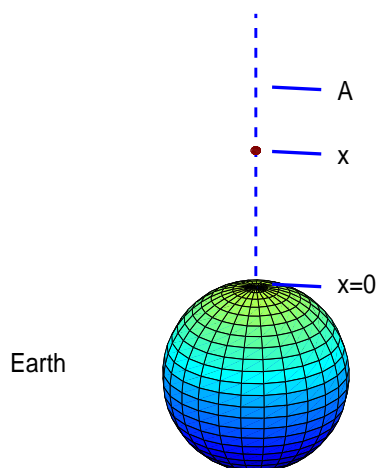

Figure 11.10: Vertical path of a satellite from Earth. The gravitational force on the satellite at height, x , is $F(x) = g R^2 / (R + x)^2$ m/sec².

Explore 11.5.1 Show that

$$W(A) = 9.8 \times m \times R^2 \left[\frac{1}{R} - \frac{1}{(R + A)} \right] \quad \blacksquare$$

How much work must be done to send the satellite 'out of Earth's gravity field', so that it does not fall back to Earth? This is

$$\lim_{A \rightarrow \infty} W(A) = \lim_{A \rightarrow \infty} 9.8 \times m \times R^2 \left[\frac{1}{R} - \frac{1}{(R + A)} \right] = 9.8 \times m \times R$$

A finite amount of work is sufficient to send the satellite out of the Earth's gravity field.

Now suppose we neglect the friction of air and ask at what velocity should the satellite be launched in order to escape the Earth? We borrow from physics the formula for kinetic energy of a body of mass m moving at a velocity v .

$$\text{Kinetic energy} = \frac{1}{2}mv^2.$$

Then we equate the kinetic energy with the work required

$$\frac{1}{2}mv^2 = 9.8 \times m \times R,$$

and solve for v . The solution is

$$v = \sqrt{2R \times 9.8} = 11,174 \text{ meters per second}$$

A satellite in orbit travels about 7,500 m/sec. The muzzle velocity of a rifle is about 1,000 m/sec. \blacksquare

Example 11.5.2 The mean and standard deviation of an exponential life table. Consider first a finite life table:

An animal population is established as newborns; 4 tenths of the population die at age 1 (perhaps harvested), 3 tenths of the population die at age 2, 2 tenths of the population die at age 3,

Age, x	$D(x)$	$L(x)$
0	0	1.0
1	0.4	1.0
2	0.3	0.6
3	0.2	0.3
4	0.1	0.1
5	0.0	0.0

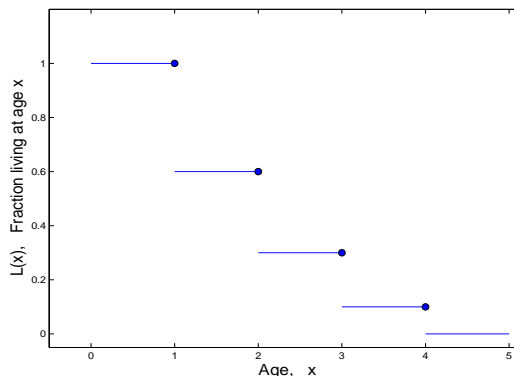

Figure 11.11: Life table and graph. $D(x)$ is the fraction of the original population that dies at age x and $L(x)$ is the fraction of the original population that live until age x .

and 1 tenth of the population die at age 4. The data may be organized as in Figure 11.11. We define $D(x)$ to be the fraction of the original population that dies at age x and $L(x)$ to be the fraction of the original population that live until age x .

The life expectancy, or average age at death, is

$$\begin{aligned}
 A &= 0.4 \times 1 + 0.3 \times 2 + 0.2 \times 3 + 0.1 \times 4 = 2 \\
 &= \sum_{x=1}^4 D(x) \times x \\
 &= \sum_{x=1}^4 (L(x) - L(x + 1)) \times x
 \end{aligned}$$

For a general life table, L , with data points $x_0, x_1, x_2, \dots, x_n$, (and $L(x_n) = 0$) the life expectancy is

$$A = x_1 (L(x_0) - L(x_1)) + x_2 (L(x_1) - L(x_2)) + \dots + x_n (L(x_{n-1}) - L(x_n))$$

If L is a differentiable approximation to a life table defined on an interval $[0, b]$ (with $L(b) = 0$) and $\{x_k\}_{k=0}^n$ is a partition of $[0, b]$, then

$$A \doteq \sum_{k=1}^n (L(x_{k-1}) - L(x_k)) \cdot x_k = \sum_{k=1}^n x_k (-L'(c_k)) (x_k - x_{k-1}) \doteq \int_0^b x(-L'(x)) dx$$

where $L(x_{k-1}) - L(x_k) = -L'(c_k) (x_k - x_{k-1})$ by the mean value theorem. The average age determined by L is

$$A = - \int_0^b xL'(x) dx \tag{11.15}$$

It is often assumed that a life table can be approximated by a negative exponential of the form

$$L(x) = e^{-\lambda x} \quad \text{where } b = \infty \text{ in Equation 11.15}$$

Then

$$\text{Average age at death} = - \lim_{R \rightarrow \infty} \int_0^R x(-\lambda e^{-\lambda x}) dx = \lambda \int_0^{\infty} x e^{-\lambda x} dx$$

Explore 11.5.2 Use integration by parts to show that

$$\int x \times e^{-\lambda x} dx = -\frac{1}{\lambda} x e^{-\lambda x} - \frac{1}{\lambda^2} e^{-\lambda x} + C \quad \blacksquare$$

Therefore, the average age at death is

$$\begin{aligned} &= \lambda \int_0^{\infty} x e^{-\lambda x} dx = \lambda \lim_{R \rightarrow \infty} \left[-x e^{-\lambda x} / \lambda - e^{-\lambda x} / \lambda^2 \right]_{x=0}^{x=R} \\ &= \lambda \lim_{R \rightarrow \infty} \left[-R e^{-\lambda R} / \lambda - e^{-\lambda R} / \lambda^2 + 1 / \lambda^2 \right] = 1 / \lambda \end{aligned}$$

By similar reasoning, the standard deviation of the age at death in the population is

$$\lambda \int_0^{\infty} (x - 1/\lambda)^2 \times e^{-\lambda x} dx$$

Explore 11.5.3 Use two steps of integration by parts to show that

$$\int (x - 1/\lambda)^2 e^{-\lambda x} dx = -(x - 1/\lambda)^2 (e^{-\lambda x} / \lambda) - 2(x - 1/\lambda) e^{-\lambda x} / \lambda^2 - 2e^{-\lambda x} / \lambda^3 \quad \blacksquare \quad (11.16)$$

In Exercise 11.5.8 you are asked to show that

$$\lambda \int_0^{\infty} (x - 1/\lambda)^2 \times e^{-\lambda x} dx = 1/\lambda^2 \quad \blacksquare \quad (11.17)$$

Exercises for Section 11.5, Improper Integrals.

Exercise 11.5.1 Show that

$$\int_1^{\infty} \frac{1}{x^a} dx = \lim_{R \rightarrow \infty} \int_1^R \frac{1}{x^a} dx$$

is finite if $1 < a$ and is infinite if $0 < a \leq 1$.

Exercise 11.5.2 Show that

$$\int_0^1 \frac{1}{x^a} dx = \lim_{r \rightarrow 0^+} \int_r^1 \frac{1}{x^a} dx$$

is finite if $0 < a < 1$ and is infinite if $1 \leq a$.

Exercise 11.5.3 Compare the regions whose areas are

$$\int_1^{\infty} \frac{1}{x^2} dx \quad \text{and} \quad \int_0^1 \frac{1}{\sqrt{x}} dx$$

Exercise 11.5.4 a. Show that

$$1 + \frac{1}{2^2} + \frac{1}{3^2} + \frac{1}{4^2} + \cdots \leq 1 + \int_0^{\infty} \frac{1}{(1+t)^2} dt.$$

See Figure 11.5.4. b. Show that

$$\frac{1}{1^2} + \frac{1}{2^2} + \frac{1}{3^2} + \frac{1}{4^2} + \cdots \leq 1.5.$$

Figure for Exercise 11.5.4 Graph of $y = 1/(1+t)^2$ and boxes of areas $1/2^2, 1/3^2, 1/4^2, \dots$.

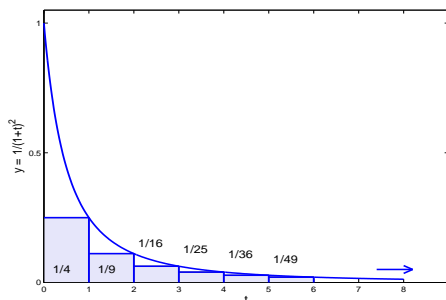

Exercise 11.5.5 a. Show that

$$1 + \frac{1}{2} + \frac{1}{3} + \frac{1}{4} + \dots \geq \int_0^\infty \frac{1}{1+t} dt.$$

See Figure 11.5.5. b. Show that

$$1 + \frac{1}{2} + \frac{1}{3} + \frac{1}{4} + \dots = \infty.$$

Figure for Exercise 11.5.5 Graph of $y = 1/(1+t)$ and boxes of areas $1, 1/2, 1/3, \dots$.

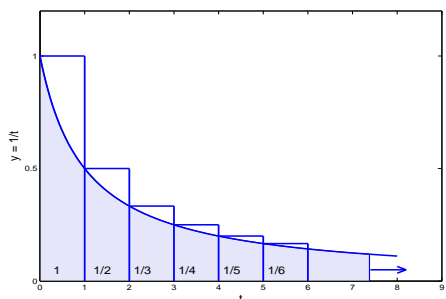

Exercise 11.5.6 Consider the infinite horn, H , obtained by rotating the graph of

$$y = 1/x, \quad 1 \leq x \quad \text{about the } x\text{-axis.}$$

See Exercise Figure 11.5.6.

- a. Show that the volume of the interior of H is π .
- b. Show that the surface area of H is greater than.

$$\int_1^\infty 2\pi \frac{1}{x} dx = \infty$$

- c. H , then, has a finite volume and can be filled with paint, but has an infinite surface area and can not be painted! I enjoyed telling a very good class about this one day. The next day Mr. Jacks, a generally casual student, told me he could paint it, and he could. His grade in the course was an A. Can you paint H ?

Figure for Exercise 11.5.6 An infinite horn, H , obtained by rotating the graph of $y = 1/x$, $1 \leq x$ about the x -axis

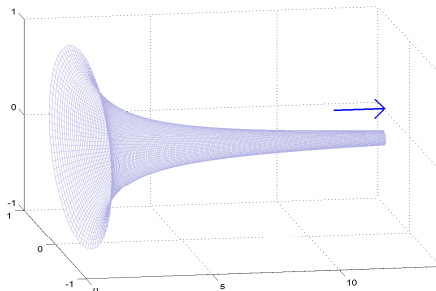

Exercise 11.5.7 The gamma function, $\Gamma(n) = \int_0^\infty x^{n-1}e^{-x} dx$ is an important function in the study of statistics.

- Compute $\Gamma(1)$.
- Use one step of integration by parts to compute $\Gamma(2)$.
- Use one step of integration by parts and the previous step to compute $\Gamma(3)$.
- Use one step of integration by parts to show that if n is an integer, $\Gamma(n + 1) = n\Gamma(n)$.

Exercise 11.5.8 Use Equation 11.16 to establish Equation 11.17

$$\lim_{R \rightarrow \infty} \frac{\lambda}{1 - e^{-\lambda R}} \int_0^R (x - 1/\lambda)^2 \times e^{-\lambda x} dx = 1/\lambda^2 \quad \blacksquare$$

Exercise 11.5.9 A linear life table is given by

$$L(x) = 1 - x/m \quad \text{for} \quad 1 \leq x \leq m$$

Find the mean and standard deviation of the life expectancy (age at death) for this life table.

Exercise 11.5.10 Wildlife managers decide to lower the level of water in a lake of 8000 acre feet. They open the gates at the dam and release water at the rate of $\frac{1000}{(t+1)^2}$ acre-feet/day where t is measured in days. Will they empty the lake?

Exercise 11.5.11 Algae is accumulating in a lake at a rate of $e^{-0.05t} \sin^2 \pi t$. The factor $e^{-0.05t}$ reflects declining available oxygen and the factor $\sin^2 \pi t$ reflects diurnal oscillation. Is the amount of algae produced infinite? See Exercise Figure 11.5.11.

Figure for Exercise 11.5.11 The amount of algae produced is the area of the shaded region (extended to $t = \infty$). The upper curve is the graph of $y = e^{-0.05t}$.

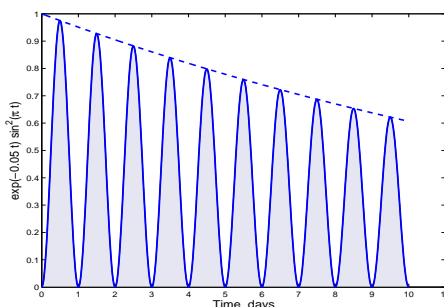

Exercise 11.5.12 Algae is accumulating in a lake at a rate of $\frac{1}{1+t} \sin^2 \pi t$. The factor $\frac{1}{1+t}$ reflects declining available oxygen and the factor $\sin^2 \pi t$ reflects diurnal oscillation. Is the amount of algae produced infinite? See Exercise Figure 11.5.12.

Figure for Exercise 11.5.12 A. The graph of $y = 1/(1+t)$. B. The amount of algae produced is the area of the shaded region in B (extended to $t = \infty$). The upper curve is the graph of $y = 1/(1+t)$.

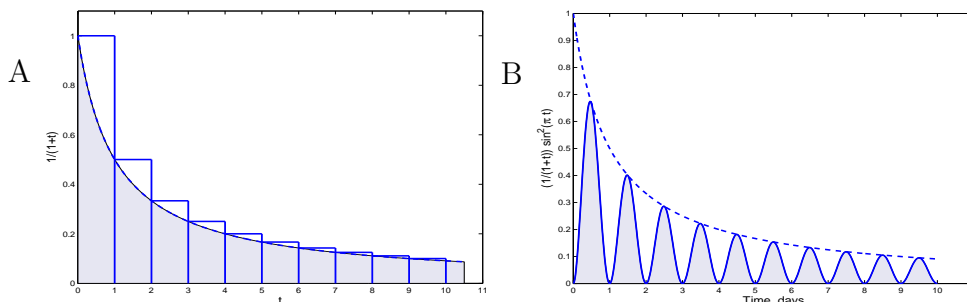

- Show that the area of the shaded region (extended to ∞) in Exercise Figure 11.5.12 A ($= \int_0^\infty \frac{1}{1+t} dt$) is infinite.
- Show that the sum of the areas of the boxes (extended to ∞) in Exercise Figure 11.5.12 A is infinite.
- Argue that the algae production on day 1 is larger than $\int_0^1 \frac{1}{2} \sin^2 \pi t dt$.
- Argue that the algae production on day 2 is larger than $\int_1^2 \frac{1}{3} \sin^2 \pi t dt$.
- Believe that for any positive integer, k ,

$$\int_k^{k+1} \sin^2 \pi t dt = \int_k^{k+1} \frac{1 - \cos 2\pi t}{2} dt = \left[\frac{1}{2}t - \frac{1}{4\pi} \sin 2\pi t \right]_k^{k+1} = \frac{1}{2}$$

- Argue that

$$\int_0^\infty \frac{1}{1+t} \sin^2 \pi t dt > \frac{1}{2} \frac{1}{2} + \frac{1}{3} \frac{1}{2} + \frac{1}{4} \frac{1}{2} + \frac{1}{5} \frac{1}{2} + \dots = \frac{1}{2} \left(\frac{1}{2} + \frac{1}{3} + \frac{1}{4} + \frac{1}{5} + \dots \right)$$

- Think of the boxes in part b. and argue that

$$\frac{1}{2} + \frac{1}{3} + \frac{1}{4} + \frac{1}{5} + \dots = \infty$$

Exercise 11.5.13 It is a fact that

$$[\arctan x]' = \frac{1}{1+x^2}$$

Compute

$$\int_0^\infty \frac{1}{1+x^2} dx$$

Chapter 12

The Mean Value Theorem and Taylor Polynomials.

Where are we going?

The graph of the function, f , has a tangent that is parallel to the secant line \overline{AB} .

The Mean Value Theorem is a careful statement supporting this assertion and is at the heart of a surprising number of explanations about functions, including, for example, the second derivative tests for maxima and minima.

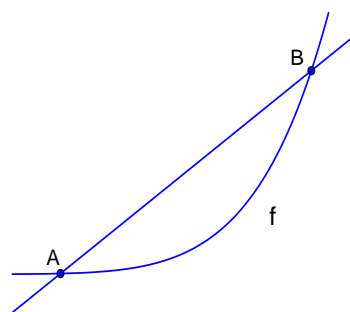

Explore 12.0.4 An eagle flies from its aerie, remains in flight for 30 minutes, and returns to the aerie. Must there have been some instant in which the eagle's flight was horizontal? ■

12.1 The Mean Value Theorem.

Theorem 12.1.1 Mean Value Theorem. Suppose f is a function defined on a closed interval $[a, b]$ and

1. f is continuous on the interval, $[a, b]$.
2. $f'(x)$ exists for every number $a < x < b$.

Then there is a number, c , with $a < c < b$ such that

$$f'(c) = \frac{f(b) - f(a)}{b - a} \quad (12.1)$$

Explore 12.1.1 Do this. Locate (approximately) a point on each graph in Explore Figure 12.1.1A and B at which the tangent is parallel to the secant. ■

Explore Figure 12.1.1 Graphs with secants; find points at which tangents to the graphs will be parallel to the secants.

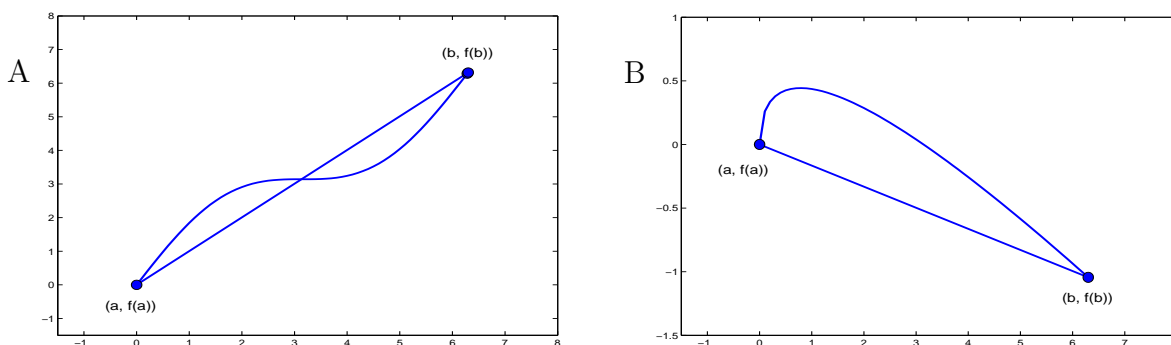

The Mean Value Theorem relates an average rate of change to a rate of change. It is surprisingly useful, despite there being uncertainty about the number c asserted to exist.

Uncertainty: Suppose a motorist travels on a turnpike which is 150 miles between the entry and exit, and the ticket records that it was 1:20 pm on entry and 3:20 pm on exit. The operator at the exit observes that the motorist was speeding, and the motorist protests that he never exceeded the 70 mph speed limit. The operator looks the car over and responds, “I see no evidence of possible discontinuous motion (as might occur in extra-terrestrial vehicles) and I am certain that at some time during your trip you were traveling 75 mph.” His reasoning is that the average speed was 75 mph so there must have been an instant at which the speed was 75 mph. He cannot say exactly when that speed was attained, only that it occurred between 1:20 and 3:20 pm.

Example 12.1.1 In special cases, we can actually find the value of c .

The Mean Value Theorem asserts that there is a tangent to the parabola $y^2 = x$ that is parallel to the secant containing $(0,0)$ and $(1,1)$. Let

$$f(x) = \sqrt{x} \quad 0 \leq x \leq 1.$$

See Example Figure 12.1.0.2A.

Figure for Example 12.1.0.2 A. Graph of $f(x) = \sqrt{x}$ and the secant through $(0,0)$ and $(1,1)$. B. The tangent at $(1/4, 1/2)$ is parallel to the secant.

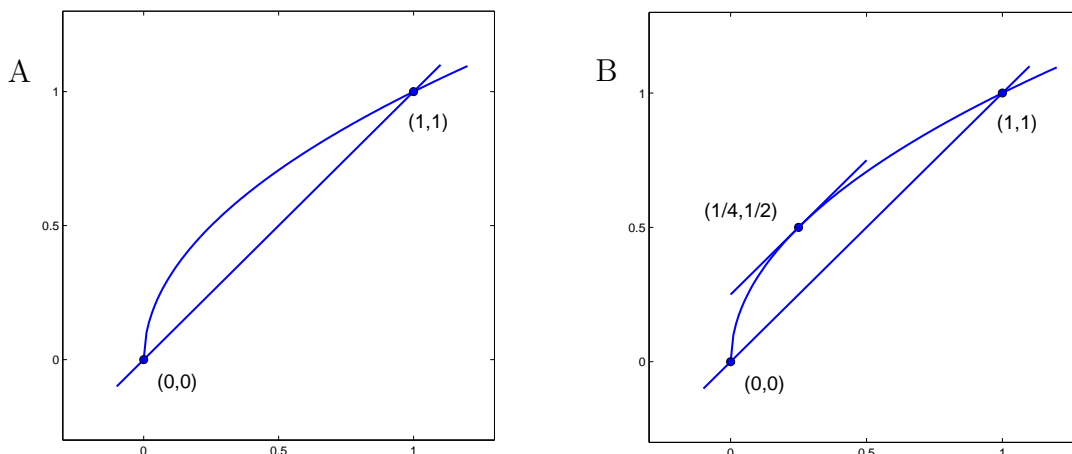

The function, f is continuous on the closed interval $[0,1]$ and

$$f'(x) = [\sqrt{x}]' = [x^{\frac{1}{2}}]' = \frac{1}{2}x^{-\frac{1}{2}} = \frac{1}{2\sqrt{x}} \quad 0 < x \leq 1$$

The parabola has a vertical tangent at $(0,0)$ and $f'(0)$ is not defined. Even so, the hypothesis of the Mean Value Theorem is satisfied; the requirement is that $f'(x)$ exist for $0 < x < 1$ – only required for points *between* 0 and 1.

We seek a tangent parallel to the secant through $(0,0)$ and $(1,1)$; the secant has slope $\frac{f(1) - f(0)}{1 - 0} = 1$, so we look for a tangent of slope 1.

The Mean Value Theorem asserts that there is a number c such that $f'(c) = 1$. We solve for c in

$$f'(c) = 1 \quad \frac{1}{2\sqrt{c}} = 1 \quad \frac{1}{2} = \sqrt{c} \quad c = \frac{1}{4}. \quad \text{Also,} \quad f\left(\frac{1}{4}\right) = \frac{1}{2}$$

The tangent to f at $(1/4, 1/2)$ has slope 1 and is parallel to the secant from $(0,0)$ to $(1,1)$ (Example Figure 12.1.0.2B.) ■

We will find good uses for the Mean Value Theorem in the next section. First, though, we tend to its proof. The strategy is to prove a special case where $f(a) = f(b) = 0$, called Rolle's Theorem, published by the French mathematician Michel Rolle in 1691. Then a proof of the general theorem is easy.

In Theorem 8.2.1 on page 351 we showed that for an interior local maximum, $(c, f(c))$, if the graph of f has a tangent at $(c, f(c))$ then that tangent is horizontal. The same assertion applies to interior local minima. See Figure 12.1

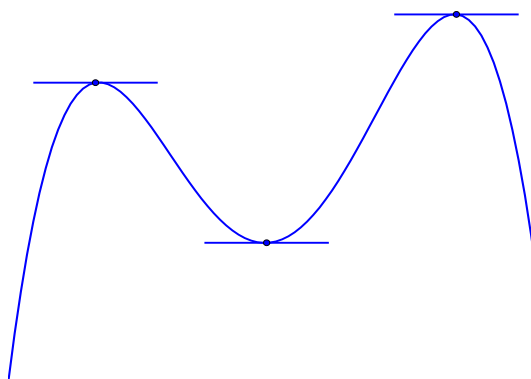

Figure 12.1: The tangents to interior local minimum and maxima are horizontal.

Theorem 12.1.2 Rolle's Theorem. If a function, f , defined on a closed interval, $[a, b]$, satisfies

1. $f(a) = f(b)$.
2. f is continuous on $[a, b]$.
3. $f'(c)$ exists for every number c , $a < c < b$.

then there is a number c between a and b for which $f'(c) = 0$.

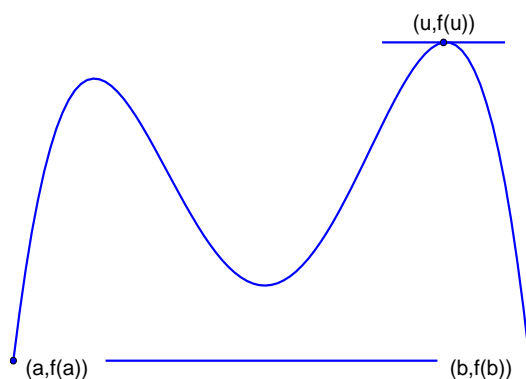

Figure 12.2: Graph with interior maximum (and endpoint minimum).

The proof is seemingly harmless. We are looking for a horizontal tangent and therefore only have to look at a high point $(u, f(u))$ and a low point $(v, f(v))$ of f on $[a, b]$.

If $a < u < b$, as in Figure 12.2, then $(u, f(u))$ is an interior local maximum and the tangent at $(u, f(u))$ is horizontal. Choose $c = u$. Then $f'(c) = 0$.

Similarly, if $a < v < b$, $(v, f(v))$ is an interior local minimum, the tangent at $(v, f(v))$ is horizontal. Choose $c = v$. Then $f'(c) = 0$.

If u and v are both end points of $[a, b]$ (meaning u is a or b and v is a or b) then for x in $[a, b]$, because $f(a) = f(b)$, the largest value of $f(x)$ is $f(a) = f(b)$ and the least value of $f(x)$ is $f(a) = f(b)$ so the only value of $f(x)$ is $f(a) = f(b)$. See Figure 12.3. Thus the graph of f is a horizontal interval and every tangent is horizontal. For the conclusion of the theorem we can choose c any point between a and b and $f'(c) = 0$.

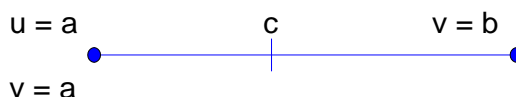
Figure 12.3: Graph with endpoint minimum, and endpoint maximum. u and v may be the same endpoint or at opposite ends of $[a, b]$.

A weakness in the preceding discussion is the presumption that the graph of f has a highest point. Under the assumptions of Theorem 12.1.2, f is continuous at every number in $[a, b]$, and there is a theorem that the graphs of such functions have high points (and low points). We ask you to accept the following theorem as true.

Theorem 12.1.3 High Point Theorem. If f is a continuous function defined on a closed interval, $[a, b]$, then there is a number c in $[a, b]$ such that for all x in $[a, b]$, $f(x) \leq f(c)$.

We ask that you accept the High Point Theorem as true without proof. **It is interesting that the High Point Theorem may be used as an alternative to the Completion Axiom 5.2.1 as an axiom of the number system (see Exercise 12.1.10).** *With the High Point Theorem accepted as true, the proof of Rolle's Theorem is complete. End of Proof.*

Example 12.1.1 The function, f , defined by

$$f(x) = \begin{cases} 0 & \text{for } x = 0 \\ \frac{1}{x} & \text{for } 0 < x \leq 1 \end{cases}$$

is defined on $[0,1]$ but does not have a highest point; nor is f continuous. See Figure 12.4 ■

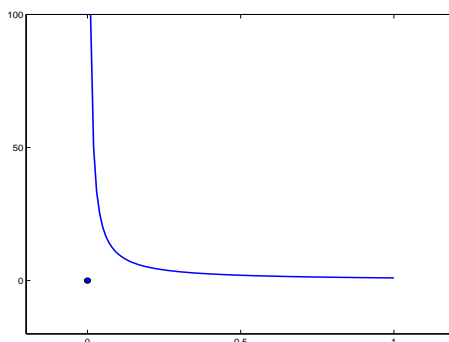

Figure 12.4: The graph of $f(0) = 0$, $f(x) = 1/x$ for $0 < x \leq 1$.

Example 12.1.2 Rolle's Theorem is useful in showing some functions are invertible. Let F be the function defined by $F(x) = x + x^3$ for all numbers, x . We will show that no horizontal line intersects the graph of F at two distinct points, which means that F is invertible. Observe that

$$F'(x) = [x + x^3]' = 1 + 3x^2 > 0 \quad \text{for all } x.$$

By Rolle's Theorem, if some horizontal line contains two points of the graph of F then at an intervening point there is a horizontal tangent and at that point $F' = 0$. This is impossible because $F'(x) = 1 + 3x^2 > 0$ for all x . Thus F is an invertible function. ■

Proof of the Mean Value Theorem. Suppose f is a continuous function on an interval $[a, b]$ and $f'(t)$ exists for $a < t < b$. An equation of the secant line through $(a, f(a))$ and $(b, f(b))$ is

$$L(x) = f(a) + \frac{f(b) - f(a)}{b - a}(x - a)$$

Let $D(x) = f(x) - L(x)$. Then D is the difference between two continuous functions, f and L , that have derivatives between a and b , so D is continuous and has a derivative between a and b .

Furthermore

$$D(a) = f(a) - \left(f(a) + \frac{f(b) - f(a)}{b - a}(a - a) \right) = 0$$

and

$$D(b) = f(b) - \left(f(a) + \frac{f(b) - f(a)}{b - a}(b - a) \right) = 0$$

(These zeros are not a surprise because f and the secant intersect at $(a, f(a))$ and $(b, f(b))$.)

Therefore D satisfies the hypothesis of Rolle's Theorem so there is a number c , $a < c < b$, such that $D'(c) = 0$. Now

$$\begin{aligned} D'(x) &= \left[f(x) - \left(f(a) + \frac{f(b) - f(a)}{b - a}(x - a) \right) \right]' \\ &= [f(x)]' - [f(a)]' - \left[\frac{f(b) - f(a)}{b - a}(x - a) \right]' \\ &= f'(x) - 0 - \frac{f(b) - f(a)}{b - a} \end{aligned}$$

and $D'(c) = 0$ leads to

$$\begin{aligned} D'(c) &= f'(c) - \frac{f(b) - f(a)}{b - a} \\ 0 &= f'(c) - \frac{f(b) - f(a)}{b - a} \\ f'(c) &= \frac{f(b) - f(a)}{b - a}, \end{aligned}$$

which is the conclusion of the Mean Value Theorem. *End of proof.*

Exercises for Section 12.1, The Mean Value Theorem.

Exercise 12.1.1 For each of the functions, F , draw a graph of F and the secant through $(a, F(a))$ and $(b, F(b))$ and a tangent to the graph of F that is parallel to the secant.

a. $F(x) = \frac{1}{x}$, $[a, b] = [1/2, 2]$ b. $F(x) = \frac{1}{x^2 + 1}$, $[a, b] = [-1, 1]$

c. $F(x) = e^x$, $[a, b] = [0, 2]$ d. $F(x) = \sin x$, $[a, b] = [0, \pi/2]$

Exercise 12.1.2 For $f(x) = x^2 + x$ find a value of c for which

$$f'(c) = \frac{f(2) - f(0)}{2 - 0} \quad \text{and} \quad 0 < c < 2$$

Locate the point $(c, f(c))$ on the graph in Ex. Figure 12.1.2 and draw its tangent.

Compute $f'(c)$.

Figure for Exercise 12.1.2 Graph of $f(x) = x^2 + x$ and the secant through $(0, f(0))$ and $(2, f(2))$

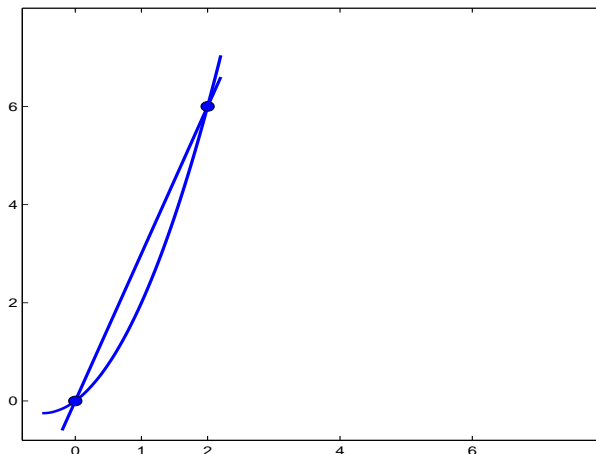

Exercise 12.1.3 Find a number c between a and b for which $f'(c) = f(b) - f(a)/(b - a)$.

- a. $f(t) = t^4$ $[a, b] = [0, 1]$
- b. $f(t) = t^3 - 3t^2 + 3t$ $[a, b] = [1, 2]$
- c. $f(t) = t^3 - 3t^2 + 3t$ $[a, b] = [1, 2]$
- d. $f(t) = \ln t$ $[a, b] = [1, e]$

Exercise 12.1.4 Show that the following functions are invertible.

- a. $F(t) = e^t$ b. $F(t) = \tan t, \quad -\frac{\pi}{2} < t < \frac{\pi}{2}$
- c. $F(t) = \ln t, \quad 0 < t$ d. $F(t) = \sqrt{5 - t}, \quad t \leq 5$

Exercise 12.1.5 The graph of the function F defined by

$$F(x) = \sqrt[3]{x^2}$$

is shown in Figure 12.1.5 together with the secant to the graph through $(-8, 4)$ and $(2, 4^{1/3})$. Is there a tangent to the graph at a point between $(-8, 4)$ and $(2, 4^{1/3})$ that is parallel to the secant between these two points? Does the Mean Value Theorem assert that there is such a tangent? Explain your answer.

Figure for Exercise 12.1.5 Graph of $y = \sqrt[3]{x^2}, -8 \leq x \leq 2$.

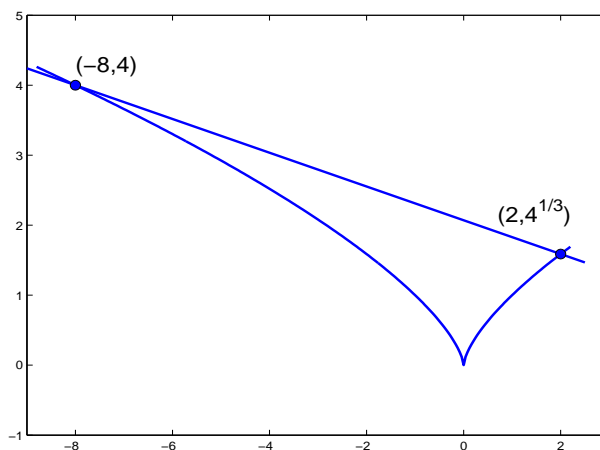

Exercise 12.1.6 The graph of the function f defined by

$$f(t) = \begin{cases} t & \text{for } 0 \leq t < 1 \\ 0 & \text{for } t = 1 \end{cases} \quad (12.2)$$

is shown in Figure Ex. 12.1.6. It does not have a high point. Furthermore, it does not have a horizontal tangent; yet it satisfies all but one of the hypotheses of Rolle's Theorem. Which hypothesis of Rolle's Theorem does it not satisfy?

Figure for Exercise 12.1.6 Graph of Equation 12.2.

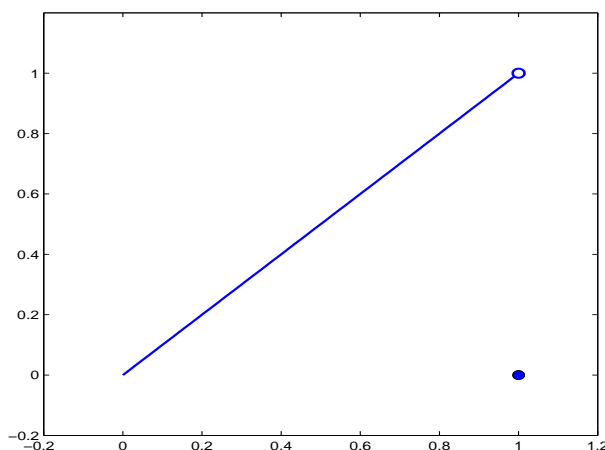

Exercise 12.1.7 . Draw the graph of a continuous function F with domain $[1,5]$ that has a non-negative derivative at every point between 1 and 5, and for which 5 is a local minimum.

The next three exercises demonstrate interesting function equivalents of the Axiom of Completeness 5.2.1 from Section 5.2.

Axiom of Completeness If S_1 and S_2 are two sets of numbers and

1. Every number belongs to either S_1 or S_2 , and
2. Every number of S_1 is less than every number of S_2 ,

then there is a number C such that C is either the largest number of S_1 or C is the least number of S_2 .

Exercise 12.1.8 Complete the proof of Theorem 12.1.5.

Theorem 12.1.4 Intermediate Value Theorem If f is a continuous function with domain an interval $[a, b]$, and $f(a) < 0$ and $f(b) > 0$ then there is a number c between a and b for which $f(c) = 0$.

Theorem 12.1.5 If the usual properties of addition, multiplication and order of the number system are assumed, one may accept the statement of the Intermediate Value Theorem 12.1.4 as an axiom and prove the statement of the Axiom of Completeness Axiom 5.2.1 (repeated above) as a theorem.

Proof. Assume the usual properties of addition, multiplication, and order of the number system and the statement of the Intermediate Value Theorem. Suppose the statement of the Completion Axiom is not true. Then there are sets of numbers, S_1 and S_2 such that every number is in either S_1 or S_2 and every number of S_1 is less than every number in S_2 and S_1 does not have a largest number and S_2 does not have a least number.

Let a be a number in S_1 and b be a number in S_2 . Consider the function f defined on $[a, b]$ by

$$f(x) = \begin{cases} -1 & \text{for } a \leq x \quad \text{and} \quad x \text{ in } S_1 \\ 1 & \text{for } x \leq b \quad \text{and} \quad x \text{ in } S_2 \end{cases} \quad (12.3)$$

Exercise 12.1.9 Prove Theorem 12.1.6:

Theorem 12.1.6 If the usual properties of addition, multiplication and order of the number system are assumed, one may accept the statement of the High Point Theorem 12.1.3 as an axiom and prove the statement of the Completion Axiom 5.2.1 as a theorem.

Exercise 12.1.10 Prove Theorem 12.1.6:

Theorem 12.1.7 If the usual properties of addition, multiplication and order of the number system are assumed, one may accept the statement of Rolle's Theorem 12.1.2 as an axiom and prove the statement of the Completion Axiom 5.2.1 as a theorem.

12.2 Monotone functions; second derivative test for high points.

With the Mean Value Theorem we can easily prove three results left from Sections 8.1 and 8.2.1. In Section 8.1 we stated that we would prove:

Theorem 12.2.1 Suppose P is a continuous function defined on an interval $[A, B]$ and at every point t in (A, B) $P'(t)$ exists and $P'(t) \geq 0$. Then P is nondecreasing on $[A, B]$.

Proof. Suppose a and b are numbers in $[A, B]$ and $a < b$. Then by the Mean Value Theorem, there is a number, c , between a and b such that

$$\frac{P(b) - P(a)}{b - a} = P'(c) \quad \text{so that} \quad P(b) - P(a) = P'(c)(b - a)$$

By hypothesis, $P'(c) \geq 0$. Also $a < b$ so that $b - a > 0$. It follows that $P(b) - P(a) \geq 0$, so that $P(a) \leq P(b)$. Therefore P is nondecreasing on $[A, B]$. End of proof.

We also stated in Section 8.1 that we would prove:

Theorem 12.2.2 Suppose P is a continuous function defined on an interval $[A, B]$ and at every point t in (A, B) $P'(t)$ exists and $P'(t) > 0$. Then P is increasing on $[A, B]$.

Proof: The argument is the similar to that for Theorem 8.1.1 and is left as Exercise 12.2.3

There are obvious corollaries to Theorem 12.2.1 ($P' \leq 0$ implies P is nonincreasing) and Theorem 12.2.2 ($P' < 0$ implies P is decreasing).

Example 12.2.1 Theorems 12.2.2 and its corollary can be used in the following way.

Problem. Let $P(x) = 3x^4 - 20x^3 - 6x^2 + 60x - 37$. On what intervals is P increasing? On what intervals is P decreasing?

Solution. We compute

$$P'(x) = 12x^3 - 60x^2 - 12x + 60 = 12(x^3 - 5x^2 - x + 5) = 12(x + 1)(x - 1)(x - 5)$$

Confession. $P(x)$, was selected so that the cubic, $P'(x)$, would factor nicely.

Now $P'(-1) = P'(1) = P'(5) = 0$ which suggests that -1, 1, and 5 might be x -coordinates of local maxima and minima. We form a chart:

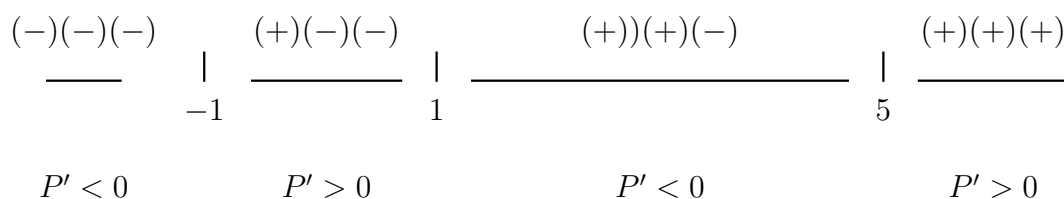

The chart means that for $x < -1$ the three binomial factors in $P' = 12(x + 1)(x - 1)(x - 5)$ are all negative so that P' is negative for all $x < -1$. This means that P is decreasing through out

$(-\infty, -1)$. By similar reasoning, P is increasing on $(-1, 1)$, decreasing on $(1, 5)$ and increasing on $(5, \infty)$.

We evaluate P at three (critical) points.

$$\begin{aligned} P(-1) &= 3(-1)^4 - 20(-1)^3 - 6(-1)^2 + 60(-1) - 37 = -80 \\ P(1) &= 0 \\ P(5) &= -512 \end{aligned}$$

These three points are plotted on the graph in Figure 12.2.0.2 and arrows indicate the increasing and decreasing character of P between the data points. A candidate for the graph of P could be drawn with just this information. In fact, the dashed line in Figure 12.2.0.2 is the graph of P ■

Figure for Example 12.2.0.2 The points $(-1,-80)$, $(1,0)$, and $(5,-512)$ are plotted with arrows showing the increasing and decreasing character of $P(x) = 3x^4 - 20x^3 - 6x^2 + 60x - 37$ on the intervals between the data points. The dashed line is the graph of P .

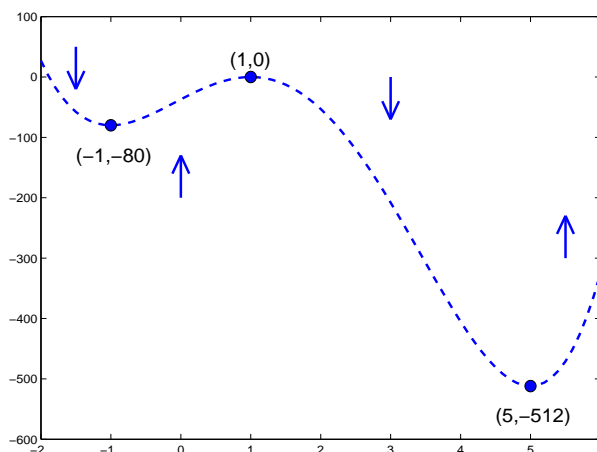

The second derivative test. In Section 8.2.1 we stated the second derivative test:

Theorem 12.2.3 Suppose f is a function with continuous first and second derivatives throughout an interval $[a, b]$ and c is a number between a and b for which $f'(c) = 0$. Under these conditions:

1. If $f''(c) > 0$ then c is a local minimum for f .
2. If $f''(c) < 0$ then c is a local maximum for f .

Proof. We prove case 1, for c to be a local minimum of f . It will be helpful to look at the numbers on the number lines shown in Figure 12.5. Because f'' is continuous and positive at c , there is an

interval, (u, v) , containing c so that f'' is positive throughout (u, v) ¹. See the top number line in Figure 12.5. Suppose x is in (u, v) (the second number line in Figure 12.5). We must show that $f(c) \leq f(x)$.

We consider the case $x < c$.

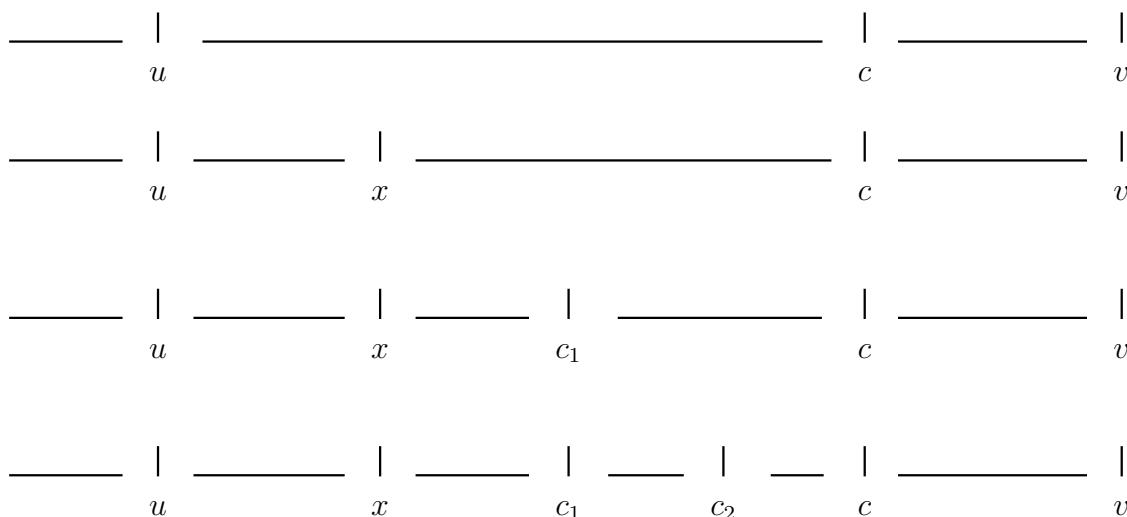

Figure 12.5: Number lines for the argument to Theorem 12.2.3.

By the Mean Value Theorem, there is a number, c_1 between x and c for which

$$\frac{f(c) - f(x)}{c - x} = f'(c_1) \quad \text{so that} \quad f(c) - f(x) = f'(c_1)(c - x) \quad (12.4)$$

See the third number line in Figure 12.5.

Watch this! By the Mean Value Theorem applied to the function f' and its derivative f'' , there is a number c_2 between c_1 and c so that

$$\frac{f'(c) - f'(c_1)}{c - c_1} = f''(c_2) \quad \text{and} \quad f'(c) - f'(c_1) = f''(c_2)(c - c_1) \quad (12.5)$$

See the bottom number line in Figure 12.5.

Remember that $f'(c) = 0$ so from the last equation (Equation 12.5)

$$f'(c_1) = -f''(c_2)(c - c_1)$$

and from this and Equation 12.4 we get

$$f(c) - f(x) = -f''(c_2)(c - c_1)(c - x)$$

Now $c > x$ and $c > c_1$ so that $c - x$ and $c - c_1$ are positive. Furthermore, $f''(c_2) > 0$ because f'' is positive throughout (u, v) . It follows that $f(c) - f(x)$ is negative, and that $f(c) < f(x)$.

The event $c < x$ is similar.

The argument for Case 2. of Theorem 12.2.3 is similar. *End of proof.*

¹This is the Locally Positive Theorem 4.1.1 of Exercise 4.1.13.

Exercises for Section 12.2, Nondecreasing and increasing functions; second derivative test for high points.

Exercise 12.2.1 Show that the following functions are invertible.

- a. $f(x) = x^2 \quad 0 \leq x$ b. $f(x) = \frac{1}{x} \quad 0 < x$
 c. $f(x) = \sin x \quad -\frac{\pi}{2} \leq x \leq \frac{\pi}{2}$ d. $f(x) = e^x \quad -\infty < x < \infty$
 e. $f(x) = \frac{x}{x^2+1} \quad -1 \leq x \leq 1$ f. $f(x) = \frac{x}{x^2+1} \quad 1 \leq x$
 g. $f(x) = \frac{e^t}{9+e^t} \quad 0 \leq x$ h. $f(x) = x|x| \quad -\infty < x < \infty$
 i. $f(x) = x^3 - 6x^2 + 9x - 4 \quad 1 \leq x \leq 3$

Exercise 12.2.2 Find the intervals on which f is increasing. Identify the local minima and local maxima. Plot the local minima and local maxima on a graph, and sketch a candidate graph of the function.

- a. $f(x) = x^2 - 3x + 7$ b. $f(x) = -x^2 + 5x + 16$
 c. $f(x) = 3x^4 + 8x^3 - 6x^2 - 24x + 17$ d. $f(x) = x^5 - 5x + 2$
 e. $f(x) = x^4 + 4x + 8$ f. $f(x) = x \ln x$
 g. $f(x) = xe^{-x}$ h. $f(x) = x^2e^{-x}$

Exercise 12.2.3 Prove Theorem 12.2.2. The proof will be similar to that for Theorem 8.1.1 except that by hypothesis $P'(c) > 0$ instead of $P'(c) \geq 0$, which leads to subsequent changes.

Exercise 12.2.4 Complete the argument for Case 1, of Theorem 12.2.3 by treating the event that $c < x$.

Exercise 12.2.5 Show that for the function

$$F(h) = (1+h)^{1/h} \quad F'(h) < 0 \quad \text{for } 0 < h \leq 1.$$

Suggestion:

$$\text{Let } \ln F(h) = \frac{1}{h} \ln(1+h), \quad \text{and show that } \frac{h^2 F'(h)}{F(h)} = \frac{h}{1+h} - \ln(1+h).$$

Note that h^2 and $F(h)$ are positive on $0 < h \leq 1$, so that to show that $F' < 0$ It is sufficient to show that

$$G(h) = \frac{h}{1+h} - \ln(1+h) \quad \text{is negative on } 0 < h \leq 1.$$

Show that $G(0) = 0$ and $G'(h) < 0$ and conclude that $G(h) < 0$ for $0 < h \leq 1$.

12.3 Approximating functions with quadratic polynomials.

Three Questions.

1. Pat is looking for Mike. Sean tells Pat that three minutes ago he saw Mike at the corner of First and Main. Where should Pat go to find Mike?
2. Pat is looking for Mike. Sean tells Pat that three minutes ago he saw Mike at the corner of First and Main and he was jogging North on Main at the rate of 2 blocks per minute. Where should Pat go to find Mike?
3. Pat is looking for Mike. Sean tells Pat that three minutes ago he saw Mike at the corner of First and Main and he was jogging North on Main at the rate of 2 blocks per minute, but Mike looked like he was getting tired. Where should Pat go to find Mike?

The first two questions above have reasonably defensible answers, and you likely worked them out as you read them.

1. If Pat only knows that Mike was at First and Main three minutes ago, it seems the best he could do is to go to First and Main and look for Mike.
2. If in addition, Pat knows that Mike was jogging North at 2 blocks per minute, Pat should look for Mike 6 blocks north of First and Main, which we will take to be Seventh and Main. This assumes that Mike's jogging remains constant, and that he is not, for example, running laps around the court house at First and Main.
3. If it looked as if Mike was getting tired, we are not sure, but Mike might also be slowing down. Perhaps Pat should look for Mike at about Fifth or Sixth and Main. The question hinges on how rapidly Mike was slowing down as a result of being tired.

Of course there might be other useful information. For example, Mike might be eating a quick energy bar and regaining some of his strength!

To make the questions more specific we pose the following similar questions.

1. Suppose f is a function and $f(0) = 1$. Ten points of your next examination depends on your estimate of $f(3)$. What is your best estimate?
2. Suppose f is a function and

$$f(0) = 1 \quad \text{and} \quad f'(0) = 2$$

What is your best estimate of $f(3)$? (Another 10 points.)

3. Suppose f is a function and

$$f(0) = 1 \quad \text{and} \quad f'(0) = 2 \quad \text{and} \quad f''(0) = -\frac{1}{4}$$

What is your best estimate of $f(3)$? (Good for 15 points.) (Note: The condition, $f''(0) = -\frac{1}{4}$ or just $f''(0)$ is negative implies that $f'(t)$ is decreasing (Pat is slowing down).)

Again the first two questions have fairly defensible answers, and we wish to develop a rational approach to the third question,

1. Knowing only that $f(0) = 1$ our best guess of $f(3)$ is also 1. Without knowledge of how f may change in $[0,3]$, our guess is that it does not change, and for all t between 0 and 3 our guess of $f(t)$ is 1.
2. If we know that $f(0) = 1$ and $f'(0) = 2$, clearly the value of f is increasing, but we assume that $f'(t)$ is unchanging from $f'(0)$ (no reason to suppose that it is either higher or lower). If so, then the graph of f is a straight line, $L(t)$, between 1 and 3 and

$$L(t) = 1 + 2t \quad \text{so that} \quad L(3) = 1 + 2 \times 3 = 7.$$

Note that the straight line $f(t) = 1 + 2t$ is perhaps the simplest function we can find for which $f(0) = 1$ and $f'(0) = 2$.

3. Now suppose that

$$f(0) = 1 \quad \text{and} \quad f'(0) = 2 \quad \text{and} \quad f''(0) = -\frac{1}{4}$$

We assume that $f''(t) = -\frac{1}{4}$ **for all** $0 \leq t \leq 3$, and our strategy is to find the most simple function, f , with these properties. We choose polynomials as 'simple' and in particular look for a parabola,

$$p(t) = p_0 + p_1 t + p_2 t^2$$

with the stated properties. We need to decide what to choose for p_0 , p_1 and p_2 . In order to **match** the information about f we will insist that

$$p(0) = 1 \quad \text{and} \quad p'(0) = 2 \quad \text{and} \quad p''(0) = -\frac{1}{4}$$

It is easy, as the array in Table 12.1 shows.

Thus we conclude that

$$p(t) = p_0 + p_1 t + p_2 t^2 = 1 + 2t - \frac{1}{8} t^2$$

has the required properties and is simple. Our guess is that

$$f(3) \quad \text{should be} \quad p(3) = 1 + 2 \cdot 3 - \frac{1}{8} 3^2 = 5\frac{7}{8}$$

For future reference, note that

$$p(t) = 1 + 2t - \frac{1}{8} t^2 \quad \text{is} \quad L(t) = 1 + 2t \quad \text{plus an additional term.}$$

Table 12.1: Array for matching coefficients of quadratics.

Analysis of $p(t)$	Value at 0	Required value	Coefficient
$p(t) = p_0 + p_1 t + p_2 t^2$	$p(t) _{t=0} = p_0$	$p(0) = 1$	$p_0 = 1$
$p'(t) = p_1 + 2p_2 t$	$p'(t) _{t=0} = p_1$	$p'(0) = 2$	$p_1 = 2$
$p''(t) = 2p_2$	$p''(t) _{t=0} = 2p_2$	$p''(0) = -\frac{1}{4}$	$p_2 = -\frac{1}{8}$

Exercises for Section 12.3, Approximating functions with quadratic polynomials.

Exercise 12.3.1 If you know that the temperature range was from a low of 60°F to a high of 84°F on Monday, what is your best estimate for the temperature range on Tuesday?

Exercise 12.3.2 Suppose you are measuring the growth of a corn plant, and observe that

- a. The plant is 14 cm tall at 10:00 am Monday and 15.5 cm tall at 10:00 am on Tuesday. What is your best guess for the height of the plant at 10:00 am on Thursday?
- b. The plant is 14 cm tall at 10:00 am on Monday, 15.5 cm tall at 10:00 am on Tuesday, and 17.5 cm tall at 10:00 am on Wednesday. What is your best guess for the height of the plant at 10:00 am on Thursday?

Exercise 12.3.3 In Table 12.1 we computed two derivatives, p' and p'' , that you should be sure you understand.

Find $p'(t)$, $p''(t)$ (the derivative of p'), $p'''(t) = p^{(3)}$ (the derivative of p''), $p^{(4)}(t) = p^{(4)}$ and $p^{(5)}(t)$. In parts f - g it is easiest to retain the binomial form and use

$$[(t - a)^n]' = n(t - a)^{n-1}.$$

- a. $p(t) = 2 + 5t - 3t^2$
- b. $p(t) = 3 - 2t + t^2 + 7t^3$
- c. $p(t) = -7 + t + 3t^2 - 5t^3 - t^4$
- d. $p(t) = a + bt + ct^2 + dt^3$
- e. $p(t) = p_0 + p_1 t + p_2 t^2 + p_3 t^3$
- f. $p(t) = 2 + 3(t - 2) + 4(t - 2)^2$
- g. $p(t) = p(t) = -3 + 4(t - 5) - 2(t - 5)^2 + \frac{1}{2}(t - 5)^3 - \frac{1}{3}(t - 5)^4$
- h. $p(t) = p_0 + p_1(t - 3) + p_2(t - 3)^2 + p_3(t - 3)^3$

Exercise 12.3.4 Find p_0 , p_1 , and p_2 for which the polynomial, $p(t) = p_0 + p_1 t + p_2 t^2$, satisfies

- a. $p(0) = 5, \quad p'(0) = -2, \quad \text{and} \quad p''(0) = \frac{1}{3}.$
- b. $p(0) = 1, \quad p'(0) = 0, \quad \text{and} \quad p''(0) = -\frac{1}{2}.$
- c. $p(0) = 0, \quad p'(0) = 1, \quad \text{and} \quad p''(0) = 0.$
- d. $p(0) = 1, \quad p'(0) = 0, \quad \text{and} \quad p''(0) = -1.$
- e. $p(0) = 1, \quad p'(0) = 1, \quad \text{and} \quad p''(0) = 1.$
- f. $p(0) = 17, \quad p'(0) = -15, \quad \text{and} \quad p''(0) = 12.$

12.4 Polynomial approximation anchored at 0.

The procedure we introduced in the previous section, Section 12.3, extends to polynomials of all degrees. It is remarkably accurate when used to approximate functions. We use it to find a cubic polynomial that approximates $\sin x$ close to the anchor point, $a = 0$. To do so, we let $f(x) = \sin x$ and compute $f(0), f'(0), f''(0),$ and $f'''(0)$. Then we seek a cubic polynomial

$$p(x) = p_0 + p_1 x + p_2 x^2 + p_3 x^3$$

that *matches* these values, meaning that

$$p(0) = f(0) \quad p'(0) = f'(0) \quad p''(0) = f''(0) \quad p'''(0) = f'''(0)$$

The information is organized in Table 12.2.

Table 12.2: Array to show the match of cubic coefficients. .

Analysis of $f(x) = \sin(x)$		Analysis of $p(x) = p_0 + p_1 x + p_2 x^2 + p_3 x^3$	
	$a = 0$		$a = 0$
$f(x) = \sin x$	$f(0) = \sin 0 = \mathbf{0}$	$p(x) = p_0 + p_1 x + p_2 x^2 + p_3 x^3$	$p(0) = \mathbf{p_0}$
$f'(x) = \cos x$	$f'(0) = \cos 0 = \mathbf{1}$	$p'(x) = p_1 + 2 p_2 x + 3 p_3 x^2$	$p'(0) = \mathbf{p_1}$
$f''(x) = -\sin x$	$f''(0) = -\sin 0 = \mathbf{0}$	$p''(x) = 2 p_2 + 3 \cdot 2 p_3 x$	$p''(0) = \mathbf{2 p_2}$
$f'''(x) = -\cos x$	$f'''(0) = -\cos 0 = \mathbf{-1}$	$p'''(x) = 3 \cdot 2 p_3$	$p'''(0) = \mathbf{3 \cdot 2 p_3}$
Match at $a = 0, \quad p_0 = 0, \quad p_1 = 1, \quad p_2 = 0, \quad p_3 = \frac{-1}{3 \cdot 2}$			

The **match** of derivatives in the last row of Table 12.2 is obtained by equating boldfaced entries in the rows above; 0,1, 0, and -1 are matched with the $p_0, p_1, 2 p_2$ and $3 \cdot 2 p_3$, respectively. We conclude that

$$p(x) = x - \frac{x^3}{2 \cdot 3} = x - \frac{x^3}{3 \cdot 2}$$

$p(x) = x - \frac{x^3}{3 \cdot 2}$ is said to be the cubic polynomial that matches $f(x) = \sin x$ at the anchor point, $a = 0$.

To see how well $p(x) = x - \frac{x^3}{3 \cdot 2}$ approximates $f(x) = \sin x$, the graphs of both are drawn in Figure 12.6, for $-\frac{\pi}{2} \leq x \leq \frac{\pi}{2}$. The graphs are indistinguishable on $-\frac{\pi}{4} \leq x \leq \frac{\pi}{4}$. The values at $\frac{\pi}{4}$ are

$$\sin \frac{\pi}{4} = 0.7071 \quad p\left(\frac{\pi}{4}\right) = 0.7047$$

so that

$$\begin{aligned} \text{Absolute Error} &= |0.7047 - 0.7071| = 0.0024 \\ \text{Relative Error} &= \frac{|0.7047 - 0.7071|}{0.7071} = 0.0034 \end{aligned} \tag{12.6}$$

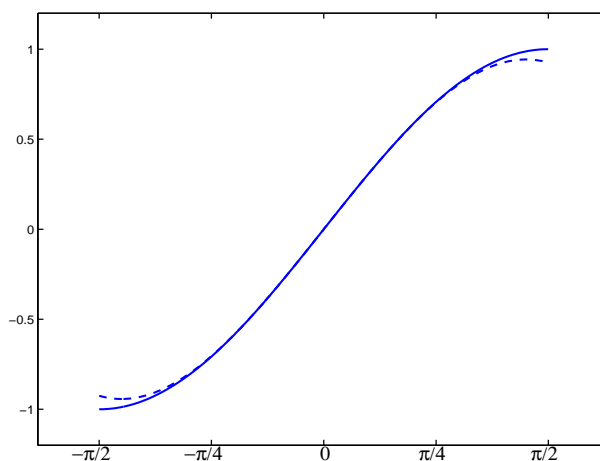

Figure 12.6: Graphs of $f(x) = \sin x$ and $p(x) = x - \frac{x^3}{3 \cdot 2}$ (dashed line), the cubic polynomial that matches the sine graph at the anchor point $a = 0$.

n! The Meaning of n Factorial.

$0! = 1$ and $1! = 1$ If n is an integer greater than 1

$$n! = 1 \cdot 2 \cdot \dots \cdot (n-1) \cdot n$$

The symbol, $n!$, is read ‘ n factorial.’ Thus $5!$ is read ‘5 factorial’ and is $1 \cdot 2 \cdot 3 \cdot 4 \cdot 5$ which is 120.

We can use more information about $f(x) = \sin x$ at $a = 0$ and find a quintic (fifth degree) polynomial that matches f at $a = 0$ and even more closely approximates f .

Let $p(x) = p_0 + p_1 x + p_2 x^2 + p_3 x^3 + p_4 x^4 + p_5 x^5$ and find p_0, p_1, p_2, p_3, p_4 and p_5 so that

$$\begin{aligned} p(0) &= f(0) & p'(0) &= f'(0) & p''(0) &= f''(0) \\ p^{(3)}(0) &= f^{(3)}(0) & p^{(4)}(0) &= f^{(4)}(0) & p^{(5)}(0) &= f^{(5)}(0) \end{aligned}$$

We could use f''' , f'''' , and f''''' , but this mode of counting is a bit primitive. It is useful to define

$$\begin{aligned} f^{(0)}(t) &= f(t) & f^{(1)}(t) &= f'(t) & f^{(2)}(t) &= f''(t) \end{aligned}$$

and $f^{(k)}(t)$ is the *k*th derivative of $f(t)$.

Analysis of $f(x) = \sin x$

$$\begin{aligned} f(x) &= \sin x & f(0) &= \sin 0 &= & \mathbf{0} \\ f'(x) &= \cos x & f'(0) &= \cos 0 &= & \mathbf{1} \\ f''(x) &= -\sin x & f''(0) &= -\sin 0 &= & \mathbf{0} \\ f^{(3)}(x) &= -\cos x & f^{(3)}(0) &= -\cos 0 &= & \mathbf{-1} \\ f^{(4)}(x) &= \sin x & f^{(4)}(0) &= \sin 0 &= & \mathbf{0} \\ f^{(5)}(x) &= \cos x & f^{(5)}(0) &= \cos 0 &= & \mathbf{1} \end{aligned}$$

Analysis of $p(x)$

Match: $\mathbf{p}^{(k)}(0) = \mathbf{f}^{(k)}(0)$

$$\begin{aligned} p(x) &= p_0 + p_1 x + p_2 x^2 + p_3 x^3 + p_4 x^4 + p_5 x^5 & p(0) &= \mathbf{p_0} & p_0 &= 0 \\ p'(x) &= p_1 + 2 p_2 x + 3 p_3 x^2 + 4 p_4 x^3 + 5 p_5 x^4 & p'(0) &= \mathbf{p_1} & p_1 &= 1 \\ p''(x) &= 2 p_2 + 3 \cdot 2 p_3 x + 4 \cdot 3 p_4 x^2 + 5 \cdot 4 p_5 x^3 & p''(0) &= \mathbf{2 p_2} & p_2 &= 0 \\ p^{(3)}(x) &= 3 \cdot 2 p_3 + 4 \cdot 3 \cdot 2 p_4 x + 5 \cdot 4 \cdot 3 p_5 x^2 & p^{(3)}(0) &= \mathbf{3 \cdot 2 p_3} & p_3 &= -\frac{1}{3!} \\ p^{(4)}(x) &= 4 \cdot 3 \cdot 2 p_4 + 5 \cdot 4 \cdot 3 \cdot 2 p_5 x & p^{(4)}(0) &= \mathbf{4 \cdot 3 \cdot 2 p_4} & p_4 &= 0 \\ p^{(5)}(x) &= 5 \cdot 4 \cdot 3 \cdot 2 p_5 & p^{(5)}(0) &= \mathbf{5 \cdot 4 \cdot 3 \cdot 2 p_5} & p_5 &= \frac{1}{5!} \end{aligned}$$

Observe that $p_0 = 0, p_1 = 1, p_2 = 0$ and $p_3 = -\frac{1}{3!}$ are the same as for the cubic approximation to the $\sin x$. The new terms are $p_4 = 0$ and $p_5 = \frac{1}{5!}$. Our quintic polynomial approximation to $\sin x$ is

$$p(x) = x - \frac{x^3}{3!} + \frac{x^5}{5!}$$

which is the previous cubic polynomial plus two terms, one of which is zero.

$$p(x) = x - \frac{x^3}{3!} + \frac{x^5}{5!} \text{ is said to be the fifth degree polynomial that matches } f(x) = \sin x \text{ at } a = 0.$$

Exercises for Section 12.4, Polynomial approximation anchored at 0.

Exercise 12.4.1 Draw the graphs of

$$f(x) = \sin x \quad \text{and} \quad p(x) = x - \frac{x^3}{3!} + \frac{x^5}{5!} \quad \text{for} \quad -7\frac{\pi}{10} \leq x \leq 7\frac{\pi}{10}$$

The graphs should be indistinguishable on $-\frac{\pi}{2} \leq x \leq \frac{\pi}{2}$.

The largest separation on $-\frac{\pi}{2} \leq x \leq \frac{\pi}{2}$ occurs at $x = \frac{\pi}{2}$ (and $x = -\frac{\pi}{2}$). Compute $f(\frac{\pi}{2})$, $p(\frac{\pi}{2})$, and the relative error in the approximation $f(\frac{\pi}{2}) \doteq p(\frac{\pi}{2})$.

Exercise 12.4.2 Find a cubic polynomial, $p(x) = p_0 + p_1 x + p_2 x^2 + p_3 x^3$ that matches $f(x) = e^x$ at $a = 0$. To do so, you should complete the following table.

Analysis of $f(x) = e^x$		Analysis of $p(x)$	Match: $\mathbf{p}^{(k)}(\mathbf{0}) = \mathbf{f}^{(k)}(\mathbf{0})$	
$f(x) = e^x$	$f(0) = e^0 = \mathbf{1}$	$p(x) = p_0 + p_1 x + p_2 x^2 + p_3 x^3$	$p(0) = \mathbf{p_0}$	$p_0 = 0$
$f'(x) = e^x$	$f'(0) = e^0 = \text{---}$	$p'(x) = p_1 + 2p_2 x + 3p_3 x^2$	$p'(0) = \mathbf{p_1}$	$p_1 = \text{---}$
$f''(x) = \text{---}$	$f''(0) = \text{---} = \text{---}$	$p''(x) = \text{---}$	$p''(0) = \text{---}$	$p_2 = \text{---}$
$f^{(3)}(x) = \text{---}$	$f^{(3)}(0) = \text{---} = \text{---}$	$p^{(3)}(x) = \text{---}$	$p^{(3)}(0) = \text{---}$	$p_3 = \text{---}$

You should conclude from the table that

$$p(x) = 1 + x + \frac{x^2}{2} + \frac{x^3}{3!}$$

is the cubic polynomial that matches $f(x) = e^x$ at $a = 0$.

Draw the graphs of $f(x) = e^x$ and $p(x) = 1 + x + x^2/2 + x^3/6$ on $-1 \leq x \leq 1$.

You should find a pretty good match. The maximum separation occurs at $x = 1$ with a maximum

$$\text{Relative error} = \frac{|1 + 1 + 1/2 + 1/6 - e^1|}{e^1} \doteq \frac{|2.6666 - 2.71828|}{e^1} \doteq 0.02$$

There is about a 2% relative error at $x = 1$.

Compute the relative error in the approximation, $e^{-1} \doteq p(-1)$.

Exercise 12.4.3 Find a fourth degree polynomial, $p(x) = p_0 + p_1 x + p_2 x^2 + p_3 x^3 + p_4 x^4$, that matches $f(x) = e^x$ at the anchor point, $a = 0$. You did most of the work in the previous exercise.

Compute the relative errors in the approximations, $e^1 \doteq p(1)$ and $e^{-1} \doteq p(-1)$.

Exercise 12.4.4 Find the quadratic polynomial, $p(x) = p_0 + p_1 x + p_2 x^2$, that matches $f(x) = \cos x$ at the anchor point, $a = 0$. Draw the graphs of $f(x)$ and $p(x)$ and discuss the accuracy of the approximation, $\cos(\frac{\pi}{4}) \doteq p(\frac{\pi}{4})$.

Exercise 12.4.5 Find the fourth degree polynomial, $p(x) = p_0 + p_1 x + p_2 x^2 + p_3 x^3 + p_4 x^4$, that matches $f(x) = \cos x$ at the anchor point, $a = 0$. Draw the graphs of $f(x)$ and $p(x)$ and discuss the accuracy of the approximation, $\cos(\frac{\pi}{4}) \doteq p(\frac{\pi}{4})$.

Exercise 12.4.6 Find a cubic polynomial, $p(x) = p_0 + p_1 x + p_2 x^2 + p_3 x^3$ that matches $f(x) = e^{-x}$ at $a = 0$.

Exercise 12.4.7 Assume that the sixth degree polynomials, $S(x)$, $C(x)$, and $E(x)$ that match, respectively, $\sin x$, $\cos x$, and e^x , are

$$S(x) = x - \frac{x^3}{3!} + \frac{x^5}{5!}$$

$$C(x) = 1 - \frac{x^2}{2!} + \frac{x^4}{4!} - \frac{x^6}{6!}$$

$$E(x) = 1 + x + \frac{x^2}{2!} + \frac{x^3}{3!} + \frac{x^4}{4!} + \frac{x^5}{5!} + \frac{x^6}{6!}$$

- Compute $S'(x)$ and compare it with $C(x)$.
- Compute $C'(x)$ and compare it with $S(x)$.
- Compute $E'(x)$ and compare it with $E(x)$.
- (Only for the adventurous.) Let $i = \sqrt{-1}$. Note that $i^2 = -1$, $i^3 = i^2 \cdot i = -i$, and $i^4 = i^2 \cdot i^2 = 1$, and continue this sequence. Compute $E(i \cdot x)$ and write it in terms of $S(x)$ and $C(x)$.

12.5 Polynomial approximations to solutions of differential equations.

The following differential equations appear in the biological literature and in this section we compute polynomial approximations to their solutions.

$$\text{a. } y' = ky \qquad \text{b. } y' = -ky$$

$$\text{c. } y' = ky(1 - y/M) \qquad \text{d. } y'' = -\omega^2 y$$

$$\text{e. } y' = ky e^{-y/\beta} - \alpha y \qquad \text{f. } y'' = -ky' - \omega^2 y$$

You can find polynomials that approximate solutions to differential equations and we illustrate this for some simple equations for which you either already know or soon will know exact solutions.

Example 12.5.1 *Problem:* Find a polynomial, $p(t) = p_0 + p_1 t + p_2 t^2 + p_3 t^3 + p_4 t^4$ that approximates the solution to

$$y'(t) = y(t), \quad y(0) = 1.$$

Solution: We need to find $p_0, p_1, p_2, p_3,$ and p_4 . We will insist that $p(t)$ matches $y(t)$ at $t = 0$, meaning that

$$p(0) = y(0), \quad p'(0) = y'(0), \quad p^{(2)}(0) = y^{(2)}(0), \quad p^{(3)}(0) = y^{(3)}(0) \quad \text{and} \quad p^{(4)}(0) = y^{(4)}(0),$$

Because

$$p(0) = p_0, \quad p'(0) = p_1, \quad p''(0) = 2p_2, \quad p^{(3)}(0) = 3 \cdot 2p_3, \quad \text{and} \quad p^{(4)}(0) = 4 \cdot 3 \cdot 2 \cdot p_4,$$

it is sufficient to find values for

$$y(0), \quad y'(0), \quad y^{(2)}(0), \quad y^{(3)}(0), \quad \text{and} \quad y^{(4)}(0).$$

We are given $y(0) = 1$.

$$\text{Because } y'(t) = y(t), \quad y'(0) = y(0) = 1.$$

$$\text{Because } y'(t) = y(t), \quad y^{(2)}(t) = y'(t), \quad \text{and} \quad y^{(2)}(0) = y'(0) = 1.$$

Continuing we get

$$y^{(2)}(t) = y'(t) \quad y^{(3)}(t) = y^{(2)}(t) \quad y^{(3)}(0) = y^{(2)}(0) = 1$$

$$y^{(3)}(t) = y^{(2)}(t) \quad y^{(4)}(t) = y^{(3)}(t) \quad y^{(4)}(0) = y^{(3)}(0) = 1$$

By insisting that

$$p(0) = y(0), \quad p'(0) = y'(0), \quad p^{(2)}(0) = y^{(2)}(0), \quad p^{(3)}(0) = y^{(3)}(0) \quad \text{and} \quad p^{(4)}(0) = y^{(4)}(0),$$

we conclude that

$$p_0 = 1, \quad p_1 = 1, \quad p_2 = \frac{1}{2}, \quad p_3 = \frac{1}{3!}, \quad \text{and} \quad p_4 = \frac{1}{4!},$$

and that

$$p(t) = 1 + t + \frac{1}{2}t^2 + \frac{1}{3!}t^3 + \frac{1}{4!}t^4.$$

You know from Chapter 5 that $y = e^t$ solves $y'(t) = y(t)$, $y(0) = 1$. The polynomial that we have found is the polynomial approximation to e^t that you (may have) found in Exercise 12.4.3. Furthermore, we are usually interested in

$$y'(t) = ky(t), \quad y(0) = y_0 \quad \text{or} \quad y'(t) = -ky(t) \quad y(0) = y_0$$

for which the solution is

$$y(t) = y_0 e^{kt} \quad \text{or} \quad y(t) = y_0 e^{-kt}$$

In the first case

$$P(t) = p(kt) = 1 + kt + \frac{1}{2}(kt)^2 + \frac{1}{3!}(kt)^3 + \frac{1}{4!}(kt)^4$$

approximates the solution and in the second case

$$P(t) = p(-kt) = 1 - kt + \frac{1}{2}(kt)^2 - \frac{1}{3!}(kt)^3 + \frac{1}{4!}(kt)^4$$

approximates the solution. ■

Example 12.5.2 *Problem:* Find a polynomial, $p(t) = p_0 + p_1 t + p_2 t^2 + p_3 t^3 + p_4 t^4$ that approximates the solution to

$$y''(t) + y(t) = 0, \quad y(0) = 1, \quad y'(0) = 0. \quad (12.7)$$

Solution: We need to find $p_0, p_1, p_2, p_3,$ and p_4 . We will insist that ' $p(t)$ match $y(t)$ at $t = 0$ ' meaning that

$$p(0) = y(0), \quad p'(0) = y'(0), \quad p^{(2)}(0) = y^{(2)}(0), \quad p^{(3)}(0) = y^{(3)}(0) \quad \text{and} \quad p^{(4)}(0) = y^{(4)}(0),$$

Because

$$p(0) = p_0, \quad p'(0) = p_1, \quad p''(0) = 2p_2, \quad p^{(3)}(0) = 3 \cdot 2p_3, \quad \text{and} \quad p^{(4)}(0) = 4 \cdot 3 \cdot 2p_4,$$

it is sufficient to find values for

$$y(0), \quad y'(0), \quad y^{(2)}(0), \quad y^{(3)}(0), \quad \text{and} \quad y^{(4)}(0).$$

We are given $y(0) = 1$ and $y'(0) = 0$.

$$\text{Because } y^{(2)}(t) + y(t) = 0, \quad y^{(2)}(t) = -y(t), \quad \text{and} \quad y^{(2)}(0) = -y(0) = -1.$$

Furthermore,

$$\begin{aligned} y^{(3)}(t) &= -y'(t) & y^{(3)}(0) &= -y'(0) = 0 \\ y^{(4)}(t) &= -y^{(2)}(t) & y^{(4)}(0) &= -y^{(2)}(0) = 1 \end{aligned}$$

By matching $p(t)$ to $y(t)$ at $t = 0$ we get

$$p_0 = 1, \quad p_1 = 0, \quad p_2 = -1/2, \quad p_3 = 0, \quad \text{and} \quad p_4 = -1/4!$$

so that

$$p(t) = 1 - \frac{t^2}{2} + \frac{t^4}{4!}$$

The solution to Equation 12.7 is $y = \cos t$ and $p(t)$ is a close approximation to $y(t)$ on the interval $[-\pi/2, \pi/2]$. For

$$y''(t) + \omega^2 y(t) = 0, \quad y(0) = 1, \quad y'(0) = 0,$$

the solution is $y(t) = \cos \omega t$ and is approximated by

$$P(t) = p(\omega t) = 1 - \frac{(\omega t)^2}{2} + \frac{(\omega t)^4}{4!}. \quad \blacksquare$$

Example 12.5.3 **If your stomach turns queazy when dissecting a frog, you should skip this example.**

Problem: Find a polynomial, $p(t) = p_0 + p_1 t + p_2 t^2 + p_3 t^3 + p_4 t^4 + p_5 t^5$ that approximates the solution to the logistic equation

$$y'(t) = y(t)(1 - y(t)), \quad y(0) = 1/2. \quad (12.8)$$

Solution: As in Examples 12.5.1 and 12.5.2 we will match derivatives at $t = 0$ to find the coefficients of p .

$$\begin{aligned}
 y'(t) &= y(t) - y^2(t) & y'(0) &= \frac{1}{4} \\
 y^{(2)}(t) &= y'(t) - 2y(t)y'(t) & y^{(2)}(0) &= 0 \\
 y^{(3)} &= y^{(2)} - 2yy^{(2)} - 2(y')^2 & y^{(3)}(0) &= -\frac{1}{8} \\
 y^{(4)} &= y^{(3)} - 2yy^{(3)} - 2y'y^{(2)} - 4y'y^{(2)} \\
 &= y^{(3)} - 6y'y^{(2)} - 2yy^{(3)} & y^{(4)}(0) &= 0 \\
 y^{(5)} &= y^{(4)} - 6y'y^{(3)} - 6(y^{(2)})^2 - 2yy^{(4)} - 2y'y^{(3)} & y^{(5)}(0) &= \frac{1}{4}
 \end{aligned}$$

By insisting that

$$a_k = \frac{y^{(k)}(0)}{k!}, \quad k = 0, 1, 2, \dots, 5$$

we get

$$p(t) = \frac{1}{2} + \frac{1}{4}t - \frac{1}{48}t^3 + \frac{1}{480}t^5$$

The actual solution to Equation 12.8 is $y(t) = e^t/(1 + e^t)$ and graphs of y and p are shown in Figure 12.5.3.3. Equation 12.8 is an equation for logistic growth with the initial population size equal to one-half the maximum supportable population (equal to 1), and $(0, 1/2)$ is an inflection point of the curve. Polynomials do not have horizontal asymptotes and must eventually increase without bound or decrease without bound. ■

Figure for Example 12.5.3.3 Graphs of $y(t) = e^t/(1 + e^t)$ and $p(t) = \frac{1}{2} + \frac{1}{4}t - \frac{1}{48}t^3 + \frac{1}{480}t^5$.

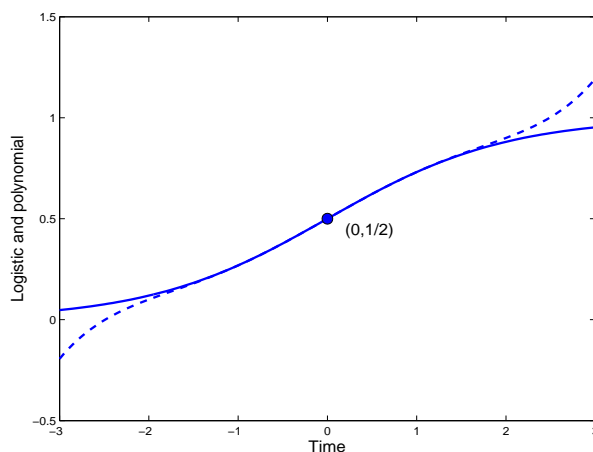

Exercises for Section 12.5, Polynomial approximation to solutions of differential equations.

Exercise 12.5.1 Find polynomials of degree specified that approximate solutions to the equations shown.

			Degree
a.	$y'(t) = -y(t)$	$y(0) = 1$	4
b.	$y''(t) = -y(t)$	$y(0) = 0$ $y'(0) = 1$	5
c.	$y''(t) = -y(t) - y'(t)$	$y(0) = 1$ $y'(0) = 0$	5
d.	$y'(t) = y(t)e^{-y(t)}$	$y(0) = 1$	3
e.	$y'(t) = y(t)e^{-y(t)} - \frac{1}{2}y(t)$	$y(0) = \ln 2$	3

Exercise 12.5.2 Suppose $y(t)$ solves

$$y' = k y(t) (1 - y(t)) \quad \text{and} \quad z(t) = M y(kt).$$

Show that $z(t)$ solves

$$z'(t) = k z(t) \left(1 - \frac{z(t)}{M}\right).$$

12.6 Polynomial approximation at anchor $a \neq 0$.

All of the polynomials approximations we have found so far have matched data at the anchor point, $a = 0$. If we wish to find a polynomial approximation to $f(x) = \ln x$, because $\ln 0$ is not defined, we will have to choose an anchor point other than $a = 0$. We can choose $a = 1$ as our anchor point, and as before, look for $p(x) = p_0 + p_1 x + p_2 x^2$ that matches $f(x) = \ln x$ at the anchor point, $a = 1$, as follows.

Analysis of f	Analysis of $p(x) = p_0 + p_1 x + p_2 x^2$	Match $\mathbf{p}^{(\mathbf{k})}(\mathbf{1}) = \mathbf{f}^{(\mathbf{k})}(\mathbf{1})$
$f(x) = \ln x$ $f(1) = \ln 1 = \mathbf{0}$	$p(x) = p_0 + p_1 x + p_2 x^2$ $p(1) = \mathbf{p_0} + \mathbf{p_1} + \mathbf{p_2}$	$p_0 + p_1 + p_2 = 0$
$f'(x) = \frac{1}{x}$ $f'(1) = \frac{1}{1} = \mathbf{1}$	$p'(x) = p_1 + 2 p_2 x$ $p'(1) = \mathbf{p_1} + \mathbf{2 p_2}$	$p_1 + 2 p_2 = 1$
$f''(x) = \frac{-1}{x^2}$ $f''(1) = -\frac{1}{1^2} = \mathbf{-1}$	$p''(x) = 2 p_2$ $p''(1) = \mathbf{2 p_2}$	$2 p_2 = -1$

Now we solve a system of equations (from bottom to top),

$$\begin{array}{lll}
 p_0 + p_1 + p_2 = 0 & p_0 + 2 + (-\frac{1}{2}) = 0 & p_0 = -\frac{3}{2} \\
 p_1 + 2p_2 = 1 & p_1 + 2 \cdot (-\frac{1}{2}) = 1 & p_1 = 2 \\
 2p_2 = -1 & p_2 = \frac{-1}{2} & p_2 = -\frac{1}{2}
 \end{array}$$

They are easy to solve, from the ‘bottom up’. That is, find $p_2 = -\frac{1}{2}$ from the last equation. Substitute $-\frac{1}{2}$ for p_2 in the second equation and compute $p_1 = 2$. Then use these two values in the first equation to solve $p_0 = \frac{3}{2}$

Now our quadratic polynomial is

$$p(x) = -\frac{3}{2} + 2x - \frac{1}{2}x^2 \quad (12.9)$$

and it can be seen in Figure 12.7 that it gives a fair fit on the interval $-\frac{1}{2} \leq x \leq \frac{1}{2}$.

Without showing the arithmetic, we claim that the cubic that matches $f(x) = \ln x$ at the anchor $a = 1$ is

$$p(x) = -\frac{11}{6} + 3x - \frac{3}{2}x^2 + \frac{1}{3}x^3. \quad (12.10)$$

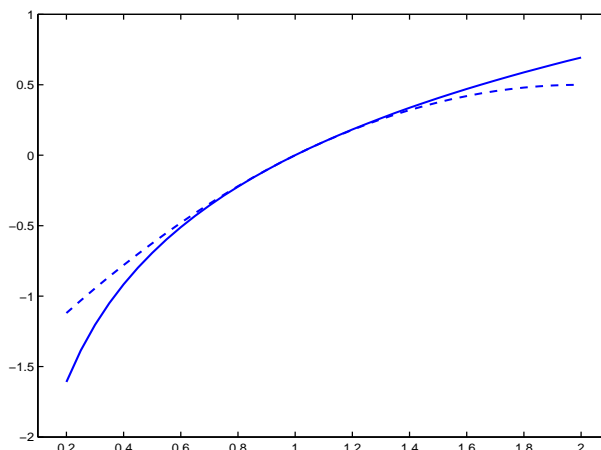

Figure 12.7: Graphs of $f(x) = \ln x$ and $p(x) = -\frac{3}{2} + 2x - \frac{1}{2}x^2$. (dashed line), the quadratic polynomial that matches the natural logarithm graph at the anchor point $a = 1$.

Observe that the terms of the cubic in Equation 12.10 have no obvious relation to the terms of the quadratic in Equation 12.9, contrary to our experience when the anchor point was $a = 0$. When the anchor of the data is $a = 1$, the polynomial form

$$p(x) = \pi_0 + \pi_1(x - 1) + \pi_2(x - 1)^2$$

is preferred for two reasons. First equations for the coefficients each involve only one unknown coefficient and are very easy to solve. More importantly, after a quadratic approximation has been obtained, if later we wish to compute a cubic approximation, its first three terms are the terms of the quadratic and we only have to compute one new coefficient. We illustrate this idea.

Compute π_0 , π_1 , and π_2 so that the quadratic

$$p(x) = \pi_0 + \pi_1(x - 1) + \pi_2(x - 1)^2$$

matches $f(x) = \ln x$ at the anchor point, $a = 1$.

Analysis of $f(x) = \ln x$

$$f(x) = \ln x \quad f(1) = \ln 1 = \mathbf{0}$$

$$f'(x) = \frac{1}{x} \quad f'(1) = \frac{1}{1} = \mathbf{1}$$

$$f''(x) = -\frac{1}{x^2} \quad f''(1) = -\frac{1}{1^2} = \mathbf{-1}$$

Analysis of $p(x) = \pi_0 + \pi_1(x - 1) + \pi_2(x - 1)^2$	Match
	$\mathbf{p}^{(\mathbf{k})}(\mathbf{1}) = \mathbf{f}^{(\mathbf{k})}(\mathbf{1})$
$p(x) = \pi_0 + \pi_1(x - 1) + \pi_2(x - 1)^2$	$p(1) = \pi_0 \quad \pi_0 = 0$
$p'(x) = \pi_1 + 2\pi_2(x - 1)$	$p'(1) = \pi_1 \quad \pi_1 = 1$
$p^{(2)}(x) = 2\pi_2$	$p^{(2)}(1) = 2\pi_2 \quad \pi_2 = -\frac{1}{2}$

Then

$$p(x) = 0 + 1 \cdot (x - 1) - \frac{1}{2} \cdot (x - 1)^2$$

is the quadratic polynomial that matches $f(x) = \ln x$ at the anchor point, $a = 1$. This is the same quadratic polynomial as first computed. We expand $(x - 1)^2$ and collect terms.

$$\begin{aligned} p(x) &= (x - 1) - \frac{1}{2}(x - 1)^2 \\ &= x - 1 - \frac{1}{2}(x^2 - 2x + 1) \\ &= x - 1 - \frac{1}{2}x^2 + x - \frac{1}{2} \\ &= -\frac{3}{2} + 2x - \frac{1}{2}x^2 \end{aligned}$$

which is the earlier quadratic form.

It is relatively easy now to compute a cubic

$$p(x) = \pi_0 + \pi_1(x - 1) + \pi_2(x - 1)^2 + \pi_3(x - 1)^3$$

that matches $f(x) = \ln x$ at the anchor point, $a = 1$.

Analysis of $f(x) = \ln x$

$f(x) = \ln x$	$f(1) = \ln 1 = \mathbf{0}$
$f'(x) = \frac{1}{x}$	$f'(1) = \frac{1}{1} = \mathbf{1}$
$f^{(2)}(x) = -\frac{1}{x^2}$	$f^{(2)}(1) = -\frac{1}{1^2} = -\mathbf{1}$
$f^{(3)}(x) = \frac{1}{2x^3}$	$f^{(3)}(1) = \frac{1}{2 \cdot 1^3} = \frac{1}{2}$

Analysis of $p(x) = \pi_0 + \pi_1(x - 1) + \pi_2(x - 1)^2 + \pi_3(x - 1)^3$	Match
	$\mathbf{p^{(k)}(1)} = \mathbf{f^{(k)}(1)}$
$p(x) = \pi_0 + \pi_1(x - 1) + \pi_2(x - 1)^2 + \pi_3(x - 1)^3$	$p(1) = \pi_0 \quad \pi_0 = 0$
$p'(x) = \pi_1 + 2\pi_2(x - 1) + 3\pi_3(x - 1)^2$	$p'(1) = \pi_1 \quad \pi_1 = 1$
$p^{(2)}(x) = 2\pi_2 + 3 \cdot 2\pi_3(x - 1)$	$p^{(2)}(1) = 2\pi_2 \quad \pi_2 = -\frac{1}{2}$
$p^{(3)}(x) = 3 \cdot 2\pi_3$	$p^{(3)}(1) = 3 \cdot 2\pi_3 \quad \pi_3 = \frac{1}{3}$

As for the quadratic, $\pi_0 = 0$, $\pi_1 = 1$, and $\pi_2 = -\frac{1}{2}$. The only new term is $\pi_3(x - 1)^3 = \frac{1}{3}(x - 1)^3$ and the cubic is

$$p(x) = 0 + 1 \cdot (x - 1) - \frac{1}{2}(x - 1)^2 + \frac{1}{3}(x - 1)^3$$

General form of the coefficients. There is a general pattern to the coefficients for an approximating polynomial with anchor point a when the polynomial is expanded in powers of $(x - a)$.

We treat the case of a third degree polynomial to illustrate the pattern.

Assume we are given a function, f , which has first, second, and third continuous derivatives and a number, a , in its domain.

Then the third degree polynomial that matches f at a is

$$p(x) = f(a) + f'(a)(x - a) + \frac{f^{(2)}(a)}{2!}(x - a)^2 + \frac{f^{(3)}(a)}{3!}(x - a)^3$$

The lower and higher degree polynomials that match f at a have a similar form.

We show the validity for the third degree polynomial. Let

$$p(x) = \pi_0 + \pi_1(x - a) + \pi_2(x - a)^2 + \pi_3(x - a)^3$$

and observe that

$p(x) = \pi_0 + \pi_1(x - a) + \pi_2(x - a)^2 + \pi_3(x - a)^3$	$p(a) = \pi_0$
$p'(x) = \pi_1 + 2\pi_2(x - a) + 3\pi_3(x - a)^2$	$p'(a) = \pi_1$
$p^{(2)}(x) = 2\pi_2 + 3 \cdot 2\pi_3(x - a)$	$p^{(2)}(a) = 2! \pi_2$
$p^{(3)}(x) = 3 \cdot 2\pi_3$	$p^{(3)}(a) = 3! \pi_3$

Now the requirement that $p^{(k)}(a) = f^{(k)}(a)$ leads to

$$\begin{array}{lll} p(a) = f(a) & \pi_0 = f(a) & \pi_0 = f(a) \\ p'(a) = f'(a) & \pi_1 = f'(a) & \pi_1 = f'(a) \\ p^{(2)}(a) = f^{(2)}(a) & 2! \pi_2 = f^{(2)}(a) & \pi_2 = \frac{f^{(2)}(a)}{2!} \\ p^{(3)}(a) = f^{(3)}(a) & 3! \pi_3 = f^{(3)}(a) & \pi_3 = \frac{f^{(3)}(a)}{3!} \end{array}$$

The general form for the cubic approximating polynomial with anchor point, a , is

$$p(x) = f(a) + f'(a)(x - a) + \frac{f''(a)}{2!}(x - a)^2 + \frac{f^{(3)}(a)}{3!}(x - a)^3$$

Lower and higher order polynomials have similar forms.

Example 12.6.1 Suppose you are monitoring a rare avian population and you have the data shown. What is your best estimate for the number of adults on January 1, 2003?

Adult Avian Census		
Jan 1, 2000	Jan 1, 2001	Jan 1, 2002
1000	1050	1080

Let t measure years after the year 2000, so that $t = 0$, $t = 1$, and $t = 2$ correspond to the years 2000, 2001, and 2002, respectively, and let $A(t)$ denote adult avian population at time t . Our problem is to estimate $A(3)$.

Solution 1. We know $A(1) = 1050$. If we knew $A'(1)$ and $A''(1)$ we could compute the degree-2 polynomial, $P(t)$, that matches $A(t)$ at the anchor point $a = 1$ and use $P(3)$ as our estimate of $A(3)$. We use the following estimates:

$$A'(a) \doteq \frac{A(a+h) - A(a-h)}{2h} \quad A''(a) \doteq \frac{A(a+h) - 2A(a) + A(a-h)}{h^2}$$

where for our problem, $a = 1$ and $h = 1$. The first estimate is what we have called the centered difference quotient estimate of the derivative; we call the second estimate the centered difference quotient estimate of the second derivative. A rationale for these two estimates appears in the discussion of Solution 2. With these estimates, we have

$$\begin{aligned} A'(1) &\doteq \frac{A(2) - A(0)}{2} \\ &= \frac{1080 - 1000}{2} = 40 \\ A''(1) &\doteq \frac{A(2) - 2A(1) + A(0)}{1^2} \\ &= \frac{1080 - 2 \cdot 1050 + 1000}{1} = -20 \end{aligned}$$

Therefore,

$$\begin{aligned} P(t) &= A(1) + A'(1)(t-1) + \frac{1}{2}A''(1)(t-1)^2 \\ &= 1050 + 40(t-1) + \frac{1}{2}(-20)(t-1)^2 \\ P(3) &= 1050 + 40 \cdot 2 + \frac{1}{2}(-20)(2)^2 = 1090 \end{aligned}$$

Our estimate of the January 1, 2003 adult population is 1090.

Solution 2. We might compute the second degree polynomial, $Q(t)$, that satisfies

$$Q(0) = A(0), \quad Q(1) = A(1), \quad \text{and} \quad Q(2) = A(2). \quad (12.11)$$

Then $Q(3)$ would be our estimate of the January 1, 2003 adult population.

It is an interesting fact that $Q(t)$ is the degree-2 polynomial, $P(t) = 1050 + 40(t-1) + \frac{1}{2}(-20)(t-1)^2$, that we computed in Solution 1. We can easily check this by substitution:

$$\begin{aligned} P(0) &= 1050 + 40 \cdot (-1) + \frac{1}{2}(-20)(-1)^2 \\ &= 1050 - 40 - 10 = 1000 \end{aligned}$$

$$P(1) = 1050$$

$$P(2) = 1050 + 40(1) + \frac{1}{2}(-20)(1)^2 = 1080$$

There is only one quadratic polynomial satisfying the three conditions 12.11, $P(t)$ is one such, so $P(t)$ is $Q(t)$. Our estimate of the January 1, 2003 adult population is again 1090.

It is a general result that if $(a-h, A(a-h))$, $(a, A(a))$, and $(a+h, A(a+h))$ are equally spaced data points then

$$P(t) = A(a) + \frac{A(a+h) - A(a-h)}{2h}(t-a) + \frac{1}{2} \frac{A(a+h) - 2A(a) + A(a-h)}{h^2}(t-a)^2 \quad (12.12)$$

is the quadratic polynomial that matches the three data points. Furthermore,

$$P'(a) \doteq \frac{A(a+h) - A(a-h)}{2h} \quad P^{(2)}(a) \doteq \frac{A(a+h) - 2A(a) + A(a-h)}{h^2} \quad (12.13)$$

These results can be confirmed by substitution and differentiation. ■

Exercises for Section 12.6, Polynomial approximation at anchor $a \neq 0$.

Exercise 12.6.1 a. Compute the fourth degree polynomial,

$$p(x) = \pi_0 + \pi_1(x-1)^2 + \pi_2(x-1)^2 + \pi_3(x-1)^3 + \pi_4(x-1)^4$$

that matches $f(x) = \ln x$ at the anchor point $a = 1$.

b. From the pattern of coefficients in p , guess the fifth degree term of a fifth degree polynomial that matches $f(x) = \ln x$ at the anchor point $a = 1$.

Exercise 12.6.2 Compute the coefficients of a quadratic polynomial, $p(x) = \pi_0 + \pi_1(x - 1) + \pi_2(x - 1)^2$ that matches the function, $f(x) = \sqrt{x}$ at the anchor point, $a = 1$. Draw the graphs of $f(x)$ and $p(x)$.

Exercise 12.6.3 Compute the coefficients of quadratic polynomials that match the following functions at the indicated anchor points:

- | Function | anchor point | Function | anchor point |
|--------------------|---------------------|--------------------|---------------------|
| a. $f(x) = \sin x$ | $a = \frac{\pi}{2}$ | b. $f(x) = \sin x$ | $a = \frac{\pi}{4}$ |
| c. $f(x) = e^x$ | $a = 1$ | d. $f(x) = x^2$ | $a = 1$ |

Exercise 12.6.4 What is your best estimate of the adult avian population for January 1, 2012 based on the following data? Which of the estimates for the four cases seems unlikely.

Adult Avian Census			
	Jan 1, 2009	Jan 1, 2010	Jan 1, 2011
Case 1.	1000	1050	1110
Case 2.	1000	1050	1100
Case 3.	1000	950	920
Case 4.	1000	980	1010

Exercise 12.6.5 Compute $P(a - h)$, $P(a)$, and $P(a + h)$ from Equation 12.12 and show that $P(a - h) = A(a - h)$, $P(a) = A(a)$, and $P(a + h) = A(a + h)$.

Exercise 12.6.6 Compute $P'(a)$ and $P''(a)$ from Equation 12.12 and confirm Equations 12.13.

12.7 The Accuracy of the Taylor Polynomial Approximations.

The polynomials we have been studying are called Taylor polynomials after an English mathematician Brooke Taylor (1685-1731) who wrote a good expository account of them in 1715. In some texts, the polynomials for the important case where the anchor point is $a = 0$ are called McLaurin polynomials after Colin McLaurin (1698-1746), who contributed to their development. We refer to them all as Taylor polynomials.

We have seen that the approximations by polynomials can be quite ‘good’. It is better to be able to quantify ‘good’ and there is a theorem to that effect.

Theorem 12.7.1 The Remainder Theorem for Taylor’s Polynomials.

Suppose f is a function with continuous first, second, third, and fourth derivatives on an interval, $[a, b]$. Then there are numbers $c_0, c_1, c_2,$ and c_3 such that

$$f(b) = f(a) + \mathbf{f}'(\mathbf{c}_0)(\mathbf{b} - \mathbf{a}) \tag{12.14}$$

$$f(b) = f(a) + f'(a)(b - a) + \frac{\mathbf{f}^{(2)}(\mathbf{c}_1)}{2!}(\mathbf{b} - \mathbf{a})^2 \tag{12.15}$$

$$f(b) = f(a) + f'(a)(b - a) + \frac{f^{(2)}(a)}{2!}(b - a)^2 + \frac{\mathbf{f}^{(3)}(\mathbf{c}_2)}{3!}(\mathbf{b} - \mathbf{a})^3 \tag{12.16}$$

$$f(b) = f(a) + f'(a)(b - a) + \frac{f^{(2)}(a)}{2!}(b - a)^2 + \frac{f^{(3)}(a)}{3!}(b - a)^3 + \frac{\mathbf{f}^{(4)}(\mathbf{c}_3)}{4!}(\mathbf{b} - \mathbf{a})^4 \tag{12.17}$$

Each formula states that the actual value of $f(b)$ is the matching polynomial value, $p(b)$, plus the remainder term that appears in bold face. There are similar formulas for higher order polynomial matches.

The numbers c_0 , c_1 , c_2 , and c_3 share the mystery of the number c in Equation 12.1 of the Mean Value Theorem. In fact, you are asked in Exercise 12.7.3 to show that Equation 12.14 is the same as the Mean Value Theorem Equation 12.1.

Lets look at the second formula, Equation 12.15, in the context of Pat looking for Mike. Suppose Mike is at First and Main, is jogging north at a *constant rate* of two blocks per minute. Let $f(t)$ be the position of Mike measured in city blocks numbered First, Second, \dots , Seventh, going north. Let t be time in minutes after Sean sees Mike at First and Main, and let $a = 0$ and $b = 3$ minutes. Because Mike's speed is constant during the three minutes, $f'(t)$ is constant ($= 2$) and therefore $f''(t) = 0$ for all t in $[0,3]$.

In the formula

$$f(b) = f(a) + f'(a)(b - a) + \frac{\mathbf{f^{(2)}(c_1)}}{2!}(\mathbf{b - a})^2,$$

$b = 3$, $a = 0$, $f'(a) = 2$, and $f^{(2)}(c_1) = 0$ so that

$$\begin{aligned} f(3) &= f(0) + f'(0)(3 - 0) + \frac{0}{2!}(3 - 0)^2 \\ &= 1 + 2(3 - 0) \\ &= 7 \end{aligned}$$

Thus Pat should look for Mike at Seventh and Main, as we thought.

Example 12.7.1 Now lets look at the last formula, Equation 12.17 for the case that $f(x) = \sin x$ and $a = 0$ and $b = \frac{\pi}{4}$. Remember that

$$\begin{aligned} f(x) &= \sin x & f(0) &= 0 \\ f'(x) &= \cos x & f'(0) &= 1 \\ f^{(2)}(x) &= -\sin x & f^{(2)}(0) &= 0 \\ f^{(3)}(x) &= -\cos x & f^{(3)}(0) &= -1 \\ f^{(4)}(x) &= \sin x \end{aligned}$$

According to Taylor's Theorem 12.7.1 and Equation 12.17, there is a number, c_3 in $[0, \frac{\pi}{4}]$ for which

$$\sin \frac{\pi}{4} = 0 + 1\left(\frac{\pi}{4} - 0\right) + \frac{0}{2!}\left(\frac{\pi}{4} - 0\right)^2 + \frac{-1}{3!}\left(\frac{\pi}{4} - 0\right)^3 + \frac{\sin(\mathbf{c_3})}{4!}\left(\frac{\pi}{4} - 0\right)^4$$

or

$$\sin \frac{\pi}{4} = \frac{\pi}{4} - \frac{1}{3!}\left(\frac{\pi}{4}\right)^3 + \frac{\sin(\mathbf{c_3})}{4!}\left(\frac{\pi}{4} - 0\right)^4. \quad (12.18)$$

What is the error in

$$\sin \frac{\pi}{4} \doteq \frac{\pi}{4} - \frac{1}{3!}\left(\frac{\pi}{4}\right)^3?$$

The answer is

$$\text{exactly } \frac{\sin(c_3)}{4!} \left(\frac{\pi}{4} - 0\right)^4.$$

Some fuzz appears. We do not know the value of c_3 . We only know that it is a number between 0 and $\frac{\pi}{4}$. We do a **worst case analysis**. The largest value of $\sin c_3$ for c_3 in $[0, \frac{\pi}{4}]$ is for $c_3 = \frac{\pi}{4}$ and $\sin \frac{\pi}{4} = \frac{\sqrt{2}}{2} \doteq 0.7071$. Therefore, we say that the error in

$$\sin \frac{\pi}{4} \doteq \frac{\pi}{4} - \frac{1}{3!} \left(\frac{\pi}{4}\right)^3 \quad \text{is no bigger than} \quad \frac{\frac{\sqrt{2}}{2}}{4!} \left(\frac{\pi}{4}\right)^4 \doteq 0.0112$$

We computed the actual error in Equation 12.6 and found it to be 0.0024. Therefore, our ‘worst case analysis’ over estimated the error by $\frac{0.0112}{0.0024}$ which is about a factor of 5. This is common in a robust analysis that guarantees the error is no bigger than the computed value. See Exercise ??.

We will prove the second formula, Equation 12.15, in Theorem 12.7.1. You are asked to prove that the first formula is the Mean Value Theorem in Exercise 12.7.3. It will be seen that the proof of the second formula is just an extension of the proof of the Mean Value Theorem. The remaining formulas of Theorem 12.7.1 have similar proofs.

We must prove that there is a number, c_1 , in $[a, b]$ for which

$$f(b) = f(a) + f'(a)(b-a) + \frac{f^{(2)}(c_1)}{2!}(b-a)^2$$

Claim: There is a number, M , such that

$$f(b) = f(a) + f'(a)(b-a) + \frac{M}{2!}(b-a)^2 \quad (12.19)$$

Just solve the previous equation for M to find the needed value. We let

$$q(x) = f(a) + f'(a)(x-a) + \frac{M}{2!}(x-a)^2 \quad (12.20)$$

and show in Figure 12.8 are graphs of f and q . You are asked in Exercise 12.7.4 to show that

$$\left. \begin{aligned} q(a) &= f(a) \\ q'(a) &= f'(a) \\ q(b) &= f(b) \end{aligned} \right\} \quad (12.21)$$

The difference D in f and q defined by

$$D(x) = f(x) - \left(f(a) + f'(a)(x-a) + \frac{M}{2!}(x-a)^2 \right)$$

is also shown in Figure 12.8.

Now we observe that $D(a) = 0$ and $D(b) = 0$.

$$D(a) = f(a) - \left(f(a) + f'(a)(a-a) + \frac{M}{2!}(a-a)^2 \right) = 0, \quad \text{and}$$

$$D(b) = f(b) - \left(f(a) + f'(a)(b-a) + \frac{M}{2!}(b-a)^2 \right) = 0$$

by the definition of M in Equation 12.19. By Rolle’s Theorem, there is a number c , $a < c < b$, so that $D'(c) = 0$. We have to compute D' .

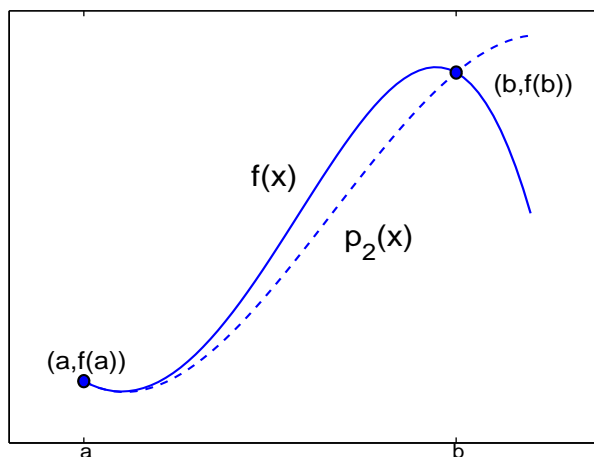

Figure 12.8: Graph of a function f and a quadratic polynomial q for which $q(a) = f(a)$, $q'(a) = f'(a)$ and $q(b) = f(b)$.

$$\begin{aligned}
 D'(x) &= \left[f(x) - \left(f(a) + f'(a)(x-a) + \frac{M}{2!}(x-a)^2 \right) \right]' \\
 &= [f(x)]' - [f(a)]' - [f'(a)(x-a)]' - \left[\frac{M}{2!}(x-a)^2 \right]' \\
 &= f'(x) - 0 - f'(a) \cdot 1 - M(x-a).
 \end{aligned}$$

Watch this! We know that $D'(c) = 0$, but we next show that $D'(a) = 0$ also. By the previous equation,

$$\begin{aligned}
 D'(a) &= f'(x) - 0 - f'(a) \cdot 1 - M(x-a)|_{x=a} \\
 &= f'(a) - 0 - f'(a) \cdot 1 - M(a-a) \\
 &= 0.
 \end{aligned}$$

Now, by Rolle's Theorem (again), because $D'(a) = 0$ and $D'(c) = 0$, there is a number (call it c_1) such that

$$D''(c_1) = 0$$

We have to compute $D''(x)$.

$$\begin{aligned}
 D''(x) &= [f'(x) - f'(a) - M(x-a)]' \\
 &= [f'(x)]' - [f'(a)]' - [M(x-a)]' \\
 &= f''(x) - M.
 \end{aligned}$$

$$D''(c_1) = 0 \quad \text{implies that} \quad f''(c_1) - M = 0 \quad \text{or} \quad M = f''(c_1) = f^{(2)}(c_1).$$

We substitute this value for M in Equation 12.19 and get

$$f(b) = f(a) + f'(a)(b-a) + \frac{f^{(2)}(c_1)}{2!}(b-a)^2$$

which is what was to be proved. Whew!

Example 12.7.2 Taylor's formula

$$f(b) = f(a) + f'(a)(b-a) + \frac{f^{(2)}(c_1)}{2!}(b-a)^2$$

provides a short proof of the second derivative test for a maximum:

If $f'(a) = 0$ and $f''(a) < 0$ then $(a, f(a))$ is a local maximum for f .

We suppose that $f^{(2)}$ is continuous so that $f^{(2)}(a) < 0$ implies that there is an interval, (p, q) surrounding a so that $f^{(2)}(x) < 0$ for all x in (p, q) .

Suppose b is in (p, q) . Then because $f'(a) = 0$

$$f(b) = f(a) + \frac{f^{(2)}(c_1)}{2!}(b-a)^2.$$

c_1 is between b and a and therefore is in (p, q) so that

$$f(b) = f(a) + \text{a negative number.}$$

Thus, $(a, f(a))$ is a local maximum for f . ■

Example 12.7.3 Taylor's Theorem provides a good explanation as to why the centered difference quotient is usually a better approximation to $f'(a)$ than is the forward difference quotient. Directly from Taylor's formula with $b = a + h$, $b - a = h$ is

$$f(a+h) = f(a) + f'(a)h + \frac{f^{(2)}(c_1)}{2!}h^2$$

we can solve for $f'(a)$ and get

$$f'(a) = \frac{f(a+h) - f(a)}{h} - \frac{f^{(2)}(c_1)}{2!}h \quad (12.22)$$

The equation states that $f'(a)$ is the forward difference quotient plus a number times h . Taylor's formula for $n = 2$ can be written twice:

$$\begin{aligned} f(a+h) &= f(a) + f'(a)h + f''(a)\frac{h^2}{2} + f^{(3)}(c_1)\frac{h^3}{6} \\ f(a-h) &= f(a) + f'(a)(-h) + f''(a)\frac{(-h)^2}{2} + f^{(3)}(c_2)\frac{(-h)^3}{6} \end{aligned}$$

Subtraction of the last two equations yields

$$f(a+h) - f(a-h) = f'(a)(2h) + \left(f^{(3)}(c_1) + f^{(3)}(c_2) \right) \frac{h^3}{6}$$

Now we solve for $f'(a)$ and get

$$\begin{aligned} f'(a) &= \frac{f(a+h) - f(a-h)}{2h} - \frac{f^{(3)}(c_1) + f^{(3)}(c_2)}{2} \frac{h^2}{6} \\ &= \frac{f(a+h) - f(a-h)}{2h} - f^{(3)}(c) \frac{h^2}{6} \end{aligned} \quad (12.23)$$

This equation states that $f'(a)$ is the centered difference quotient plus a number times h^2 .

The number h used in computing difference quotients should be small, say 0.01, so that h^2 is smaller, (0.0001), suggesting that the error term in the centered difference quotient is smaller than the error in the forward difference quotient. This advantage may be nullified, however, if $f^{(3)}(c)/6$ greatly exceeds $f^{(2)}(c_2)/2$. ■

Exercises for Section 12.7, The Accuracy of the Taylor Polynomial Approximations.

Exercise 12.7.1 Find a bound on the error of the Taylor's polynomial approximation anchored at $a = 0$ and of indicated degree to

- $f(x) = \cos x$, of degree 2, on $[0, \pi/4]$.
- $f(x) = e^x$, of degree 4 on $[0, 1]$.
- $f(x) = \cos x$, of degree 4 on $[0, \pi/2]$.
- $f(x) = \sin x$, of degree 5, on $[0, \pi/2]$.
- $f(x) = \ln(1+x)$ of degree 5 on $[0, 1/2]$.
- $f(x) = \sin x$ of degree 4 on $[0, \pi/4]$.

Exercise 12.7.2 a. We showed in Example 12.7.1 that (Equation 12.18)

$$\sin \frac{\pi}{4} = \frac{\pi}{4} - \frac{1}{3!} \left(\frac{\pi}{4}\right)^3 + \frac{\sin(c_3)}{4!} \left(\frac{\pi}{4} - 0\right)^4$$

for some number c_4 in $[0, \pi/4]$ and that

$$\left| \frac{\sin(c_3)}{4!} \left(\frac{\pi}{4} - 0\right)^4 \right| \leq 0.0112.$$

Show that

$$\sin \frac{\pi}{4} = \frac{\pi}{4} - \frac{1}{3!} \left(\frac{\pi}{4}\right)^3 + \frac{\cos(c_4)}{5!} \left(\frac{\pi}{4} - 0\right)^5$$

for some number c_4 in $[0, \pi/4]$ and that

$$\left| \frac{\cos(c_4)}{5!} \left(\frac{\pi}{4} - 0\right)^5 \right| \leq 0.0025.$$

b. How does 0.0025 compare with the actual error in the approximation,

$$\sin(\pi/4) \doteq \frac{\pi}{4} - \frac{1}{3!} \left(\frac{\pi}{4}\right)^3 \quad ?$$

Exercise 12.7.3 Rearrange the formula, Equation 12.14, $f(b) = f(a) + f'(c_0)(b - a)$ and show that it is the a statement of the Mean Value Theorem.

Exercise 12.7.4 Show that the function, q defined in Equation 12.20 has the properties stated in Equation 12.21.

Exercise 12.7.5 Add the two versions of Taylor's third order polynomial with error, Equation 12.17:

$$f(a+h) = f(a) + f'(a)h + \frac{f^{(2)}(a)}{2!}h^2 + \frac{f^{(3)}(a)}{3!}h^3 + \frac{f^{(4)}(c_1)}{4!}h^4$$

$$f(a-h) = f(a) - f'(a)h + \frac{f^{(2)}(a)}{2!}h^2 - \frac{f^{(3)}(a)}{3!}h^3 + \frac{f^{(4)}(c_2)}{4!}h^4,$$

and solve for $f^{(2)}(a)$. You should find that (after a slight alteration)

$$f^{(2)}(a) = \frac{f(a+h) - 2f(a) + f(a-h)}{h^2} - \frac{f^{(4)}(c_1) + f^{(4)}(c_2)}{2} \frac{h^2}{12}$$

Use the intermediate value property to argue that there is a number c such that

$$f^{(2)}(a) = \frac{f(a+h) - 2f(a) + f(a-h)}{h^2} - f^{(4)}(c) \frac{h^2}{12} \quad (12.24)$$

This provides a good formula for approximating second derivatives.

Exercise 12.7.6 Use Theorem 12.7.1 to show that

- a. For any number positive number, x , there is a number c , $0 < c < x$, such that

$$e^x = 1 + x + \frac{x^2}{2} + \frac{x^3}{6} + \frac{c^4}{24}.$$

- b. For any number positive number, x , there is a number c , $0 < c < x$, such that

$$e^{-x} = 1 - x + \frac{x^2}{2} - \frac{x^3}{6} + \frac{c^4}{24}.$$

Chapter 13

Two Variable Calculus and Diffusion.

Where are we going?

Most measurable biological quantities are dependent on more than one variable; they are functions of two or more variables. The concepts of derivative and integral of a function of one variable is extended to functions of two variables in this chapter. Conditions for local maxima and minima of functions of two variables are presented and integrals of functions of two variables are computed as iterated integrals.

Functions of two variables may describe diffusion of disease, invasive species, heat, or chemicals in space and time dimensions. An equation that relates partial derivatives with respect to a space variable and with respect to time is introduced and used to quantify diffusion processes.

13.1 Partial derivatives of functions of two variables.

Most measurable biological quantities are dependent on more than one variable. Corn yield is measurably dependent on rainfall, number of degree-days and available nitrogen, potassium, and phosphorus. Brain development in children is dependent on several nutritional factors as well as environmental factors such as rest and sociological experiences.

A function of two variables is a rule that assigns to each ordered number pair in a set called its domain a number in a set called its range. Examples include

$$F(x, y) = x^2 + y^2 \quad F(x, y) = x e^{-y^2} \quad F(x, y) = \sin(x + y) \quad F(x, y) = \sqrt{x} \ln y$$

The domains of the first three functions implicitly are all number pairs (x, y) . The first function assigns to the number pair (x, y) the number $x^2 + y^2$; it assigns to $(-2, 3)$ the number 13, for example. The domain of $F(x, y) = \sqrt{x} \ln y$ implicitly is the set of number pairs (x, y) for which $x \geq 0$ and $y > 0$. In each example, the first variable of F is x and the second variable of F is y .

Graphs of functions of two variables can be visualized in three-dimensional space (3-space) with the domain D lying in a horizontal x, y plane and the vertical axis being $z = F(x, y)$. Shown in Figure 13.1A is the graph of $F(x, y) = 2$ which is a horizontal plane a distance 2 above the x, y plane. Shown in Figure 13.1B is a graph of the function $F(x, y) = x(1 - x) + y(1 - y)^2$. Additional graphs of functions of two variables are shown in Figure 13.2. In drawing such graphs, it is customary to use a **”right-handed axis system.”** Visualize your right hand holding the z -axis

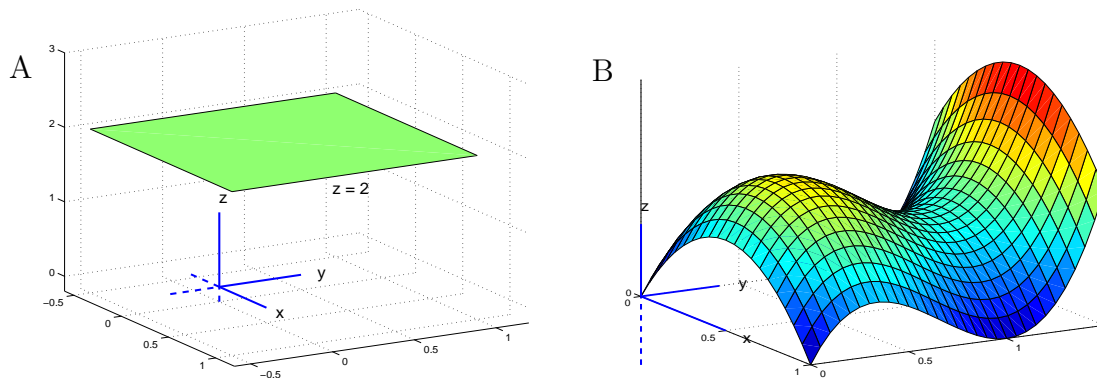

Figure 13.1: Graph in 3-dimensional space of A. $F(x, y) = 2$ and B. $F(x, y) = x(1-x) + y(1-y)^2$.

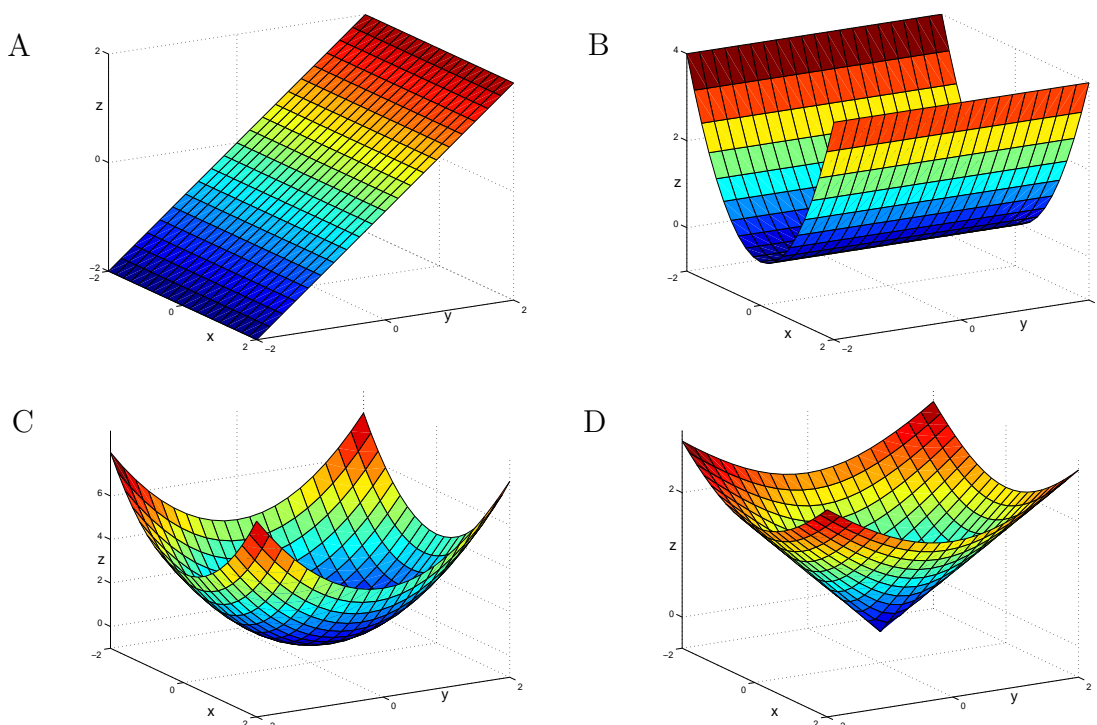

Figure 13.2: Graphs in 3-dimensional space of A. $F(x, y) = y$, B. $F(x, y) = x^2$, C. $F(x, y) = x^2 + y^2$, D. $F(x, y) = \sqrt{x^2 + y^2}$.

and aligned so that your thumb lies on and points in the direction of the positive z -axis. Then in a right-handed system, your fingers will point from the positive x -axis to the positive y -axis.

A linear function of two variables is a function of the form $F(x, y) = ax + by + c$ where a , b , and c are numbers. For example, $F(x, y) = 2x + 3y - 6$ is a linear function and the graph of $z = 2x + 3y - 6$ in Figure 13.3 is a plane in three-dimensional space. The portion of the graph of $z = 2x + 3y - 6$ that lies in the plane $y = 0$ (marked A) is the line $z = 2x - 6$ in the x, z plane. The x, z plane is the set of all points $(x, 0, z)$ in 3-space. The portion of the graph of $z = 2x + 3y - 6$ that lies in the plane $x = 0$ (marked B) is the line $z = 3y - 6$ in the y, z plane. The portion of the graph of $z = 2x + 3y - 6$ that lies in the plane $z = 0$ (marked C) is the line $0 = 2x + 3y - 6$ in the $(x, y, 0)$ plane.

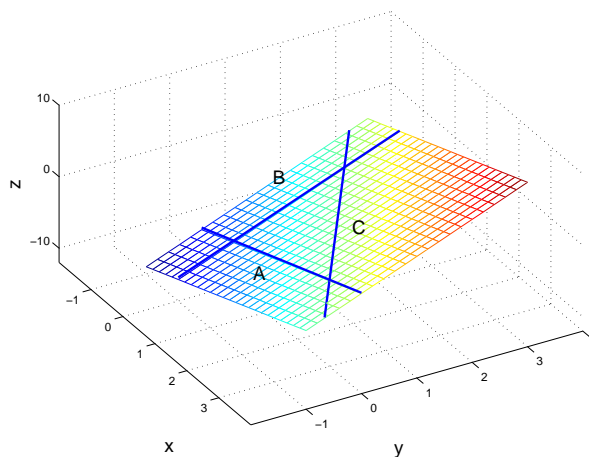

Figure 13.3: Graph of the plane $z = 2x + 3y - 6$ in three dimensional space. The line marked 'A' is the slice of that plane with $y = 0$. The line marked 'B' is the slice with $x = 0$, and the line marked 'C' is the 'level curve' with $z = 0$.

Definition 13.1.1 Partial Derivative. Suppose F is a function of two variables and (a, b) is in the domain of F . The partial derivative of F with respect to its first variable, denoted by F_1 , is the ordinary derivative of F with respect to its first variable *with the second variable held constant*. Similarly, the partial derivative of F with respect to its second variable, denoted by F_2 , is the ordinary derivative of F with respect to its second variable *with the first variable held constant*.

Second order derivatives are denoted by $F_{1,1}$, $F_{1,2}$, $F_{2,1}$, and $F_{2,2}$ where $F_{i,j}$ is the derivative of F_i with respect to the j th variable.

The limit definitions of partial derivatives are

$$F_1(a, b) = \lim_{h \rightarrow 0} \frac{F(a + h, b) - F(a, b)}{h} \quad F_2(a, b) = \lim_{h \rightarrow 0} \frac{F(a, b + h) - F(a, b)}{h}. \tag{13.1}$$

The Leibnitz notation can be particularly helpful in writing partial derivatives of $F(x, y)$.

$$F_1(a, b) = \frac{\partial F}{\partial x}(a, b), \quad F_2(a, b) = \frac{\partial F}{\partial y}(a, b),$$

$$F_{1,1}(a, b) = \frac{\partial^2 F}{\partial x^2}(a, b), \quad F_{1,2}(a, b) = \frac{\partial^2 F}{\partial y \partial x}(a, b), \quad F_{2,2}(a, b) = \frac{\partial^2 F}{\partial y^2}(a, b).$$

When notations for the domain variables of F are clear, as in $F = F(x, y)$ it is helpful to write, for examples,

$$\begin{aligned} F_1(x, y) &= F_x(x, y), & F_{1,1}(x, y) &= F_{xx}(x, y), \\ & & \text{and} & \\ F_2(x, y) &= F_y(x, y), & F_{2,1}(x, y) &= F_{yx}(x, y). \end{aligned}$$

Some examples of partial derivatives are:

$$F(x, y) = x^2 + y^2$$

$$\begin{array}{lll} F_1(x, y) = 2x & F_{1,2}(x, y) = 0 & F_2(x, y) = 2y \\ F_{1,1}(x, y) = 2 & F_{2,1}(x, y) = 0 & F_{2,2}(x, y) = 2 \end{array}$$

$$F(x, y) = x e^{-y^2}$$

$$\begin{array}{lll} F_1(x, y) = e^{-y^2} & F_{1,2}(x, y) = e^{-y^2} (-2y) & F_2(x, y) = x e^{-y^2} (-2y) \\ F_{1,1}(x, y) = 0 & F_{2,1}(x, y) = e^{-y^2} (-2y) & F_{2,2}(x, y) = -2x e^{-y^2} + 4xy^2 e^{-y^2} \end{array}$$

$$F(x, y) = \sin(x + y)$$

$$\begin{array}{lll} F_x(x, y) = \cos(x + y) & F_{xy}(x, y) = -\sin(x + y) & F_y(x, y) = \cos(x + y) \\ F_{xx}(x, y) = -\sin(x + y) & F_{yx}(x, y) = -\sin(x + y) & F_{yy}(x, y) = -\sin(x + y) \end{array}$$

$$F(x, y) = x^{1/2} \ln y$$

$$\begin{array}{lll} \frac{\partial F(x, y)}{\partial x} = (1/2)x^{-1/2} \ln y & \frac{\partial^2 F(x, y)}{\partial x \partial y} = (1/2)x^{-1/2} y^{-1} & \frac{\partial F(x, y)}{\partial y} = x^{1/2} y^{-1} \\ \frac{\partial^2 F(x, y)}{\partial^2 x} = -(1/4)x^{-3/2} \ln y & \frac{\partial^2 F(x, y)}{\partial y \partial x} = (1/2)x^{-1/2} y^{-1} & \frac{\partial^2 F(x, y)}{\partial y^2} = -x^{1/2} y^{-2} \end{array}$$

In all of these cases, and usually, $F_{1,2} = F_{2,1}$. Always when $F_{1,2}$ and $F_{2,1}$ are continuous they are equal.

Definition 13.1.2 Limit and continuity of a function of two variables.

Suppose F is a function of two variables with domain D and (a, b) is a point of D and for every positive number δ there is a point (x, y) of D such that $0 < \sqrt{(x - a)^2 + (y - b)^2} < \delta$, and L is a number. Then

$$\lim_{(x,y) \rightarrow (a,b)} F(x, y) = L$$

means that if ϵ is a positive number, there is a positive number δ such that if (x, y) is in D and $0 < \sqrt{(x - a)^2 + (y - b)^2} < \delta$ then $|F(x, y) - L| < \epsilon$. The statement that F is continuous at (a, b) means that

$$\lim_{(x,y) \rightarrow (a,b)} F(x, y) = F(a, b)$$

or that there is a number $\delta_0 > 0$ such that for every point (x, y) of D distinct from (a, b) , $\sqrt{(x - a)^2 + (y - b)^2} > \delta_0$.

Explore 13.1.1 Identify the points of the graphs in Explore Figure 13.1.1 A and B at which the graphs are discontinuous.

Explore Figure 13.1.1 A. $F(x, y) = 1$ if $x^2 \leq y$; else $F(x, y) = 0$.

B. $F(x, y) = -(1 + x/2) \sin(\pi y/2)$ for $x < 0$ and $-2 < y < 0$, $F(x, y) = (1 - x/2) \sin(\pi y/2)$ for $x > 0$ and $-2 < y < 0$.

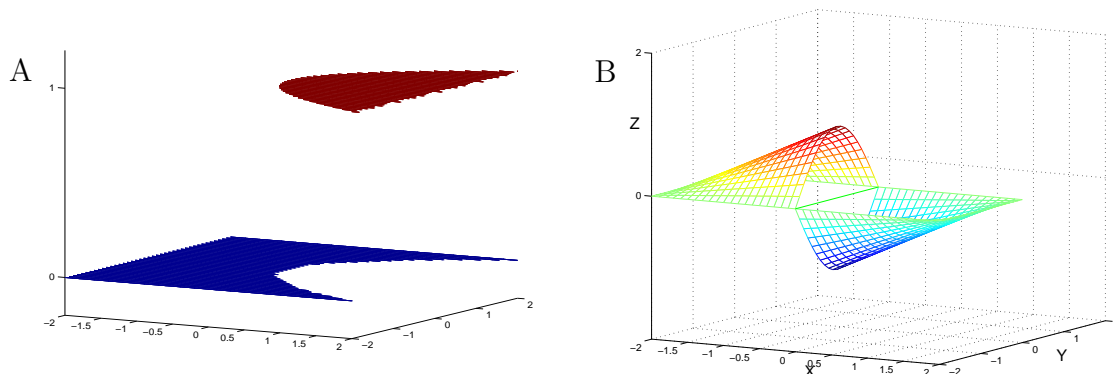

In Figure 13.4, slices of the graph of

$$F(x, y) = x(1 - x)^2 + y^2(1 - y)$$

corresponding to $x = 0.2$ and $y = 0.4$ are shown. The line tangent to the slice $x = 0.2$ at the point $(0.2, 0.6, 0.0432)$ is drawn. Its slope is

$$F_2(0.2, 0.6) = 0 + 2y(1 - y) - y^2 \Big|_{(x,y)=(0.2,0.6)} = 0.12.$$

The line tangent to the slice $y = 0.4$ at the point $(0.4, 0.4, 0.24)$ is also drawn. Its slope is

$$F_1(0.3, 0.4) = (1 - x)^2 - 2x(1 - x) \Big|_{(x,y)=(0.4,0.4)} = -0.12$$

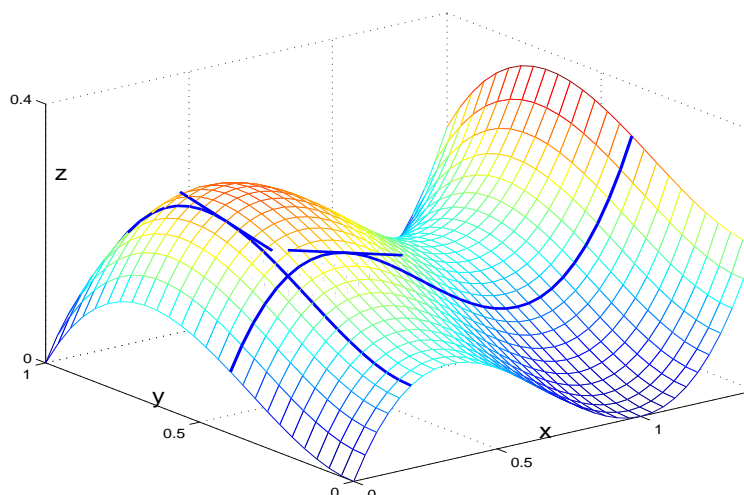

Figure 13.4: Graph in 3-dimensional space of $F(x, y) = x(1 - x)^2 + y^2(1 - y)$ and slices through the graph at $x = 0.2$ and $y = 0.4$. Observe that this is still a righthanded system although the x - and y -axes are not the same as in previous graphs.

Definition 13.1.3 Local linear approximation, tangent plane. Suppose F is a function of two variables, (a, b) is a number pair in the domain of F , and F_1 and F_2 exist and are continuous on the interior of a circle with center (a, b) . Then the local linear approximation to F at (a, b) is the linear function

$$L(x, y) = F(a, b) + F_1(a, b)(x - a) + F_2(a, b)(y - b) \quad (13.2)$$

The graph of L is the *tangent plane* to the graph of F at $(a, b, F(a, b))$, and F is said to be differentiable at (a, b) .

For $F(x, y) = x^2 + y^2$, $F_1(x, y) = 2x$, and $F_2(x, y) = 2y$. At the point $(1, 2)$, F_1 and F_2 are continuous on the circle of radius 1 and center $(1, 2)$ (actually continuous everywhere), and

$$F(1, 2) = 5, \quad F_1(1, 2) = 2x|_{x=1, y=2} = 2, \quad F_2(1, 2) = 4,$$

The local linear approximation to F at $(1, 2)$ is

$$L(x, y) = 5 + 2(x - 1) + 4(y - 2).$$

A graph of F and L appear in Figure 13.5. The graph of L is below the graph of F except at the point of tangency, $(1, 2, 5)$.

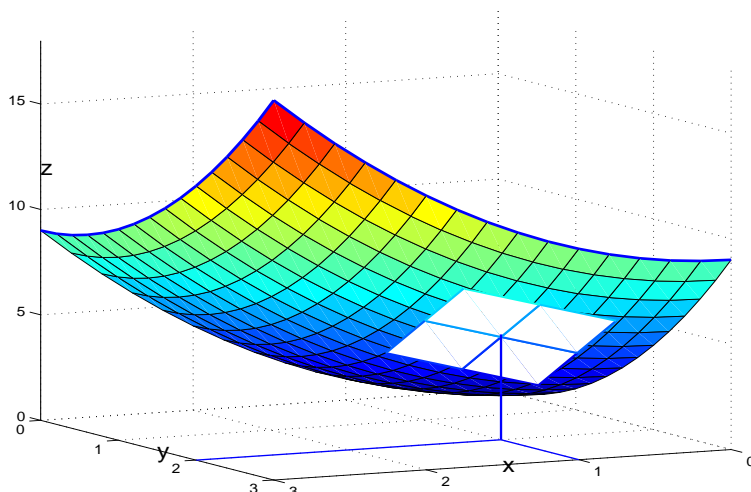

Figure 13.5: Graph in 3-dimensional space of $z = F(x, y) = x^2 + y^2$ and a square lying in the tangent plane at $(1, 2, 5)$, $L(x, y) = 5 + 2(x - 1) + 4(y - 2)$, which is below the graph of F except at the point of tangency, $(1, 2, 5)$. View is from below the graph. Is this a righthanded axis system?

For a function, $F(x, y)$, of two variables to have a tangent it is necessary that $F_1(x, y)$ and $F_2(x, y)$ be continuous. For functions f of one variable, the tangent line to the graph of f at $(a, f(a))$ is simply the line $y = f(a) + f'(a)(x - a)$; $f'(a)$ must exist, but there is no requirement

that $f'(x)$ be continuous or even exist for $x \neq a$. For functions of two variables to have a linear approximation, more is required. The example,

$$F(x, y) = \sqrt{|xy|}$$

illustrates the need for conditions beyond the existence of $F_1(a, b)$ and $F_2(a, b)$ in order that there be a tangent plane at $(a, b, F(a, b))$. See Figure 13.6.

$$\begin{aligned} \text{For } F(x, y) &= \sqrt{|xy|}, & F(0, 0) &= 0 \\ F(x, 0) &= 0, & F_1(0, 0) &= 0, \\ F(0, y) &= 0, & F_2(0, 0) &= 0. \end{aligned}$$

so the local linear approximation at $(0,0)$ might be

$$L(x, y) = 0 + 0 \times (x - 0) + 0 \times (y - 0) = 0,$$

the graph of which is the horizontal plane $z = 0$. However, the slice of the graph through $y = x$ for

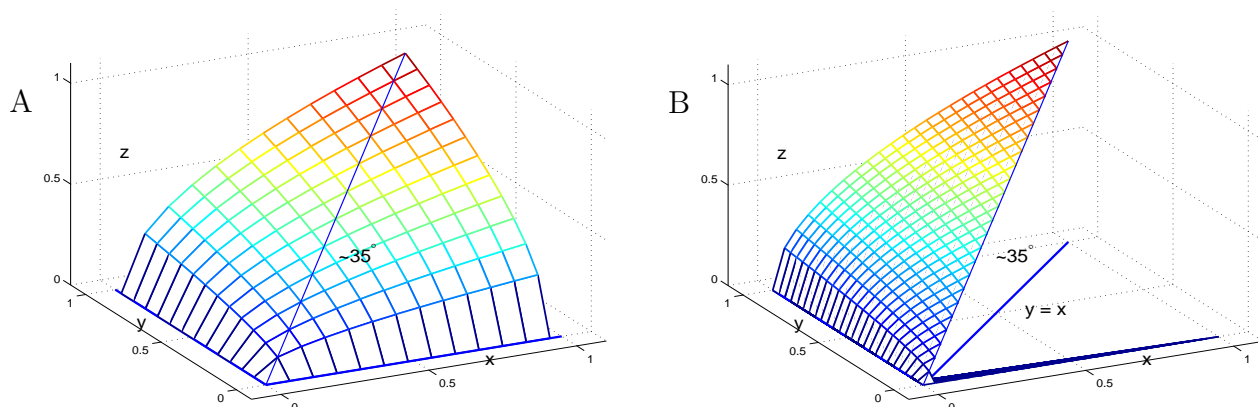

Figure 13.6: A. Graph of $F(x, y) = \sqrt{|xy|}$ on $x \geq 0, y \geq 0$. The rest of the graph is obtained by rotation of the portion shown about the z -axis 90, 180 and 270 degrees. There is no local linear approximation to F at $(0,0)$ and no tangent plane to the graph of F at $(0,0,0)$. B. Cut away of the graph of A showing the angle between the surface and the horizontal plane above the line $y = x$.

which $z = |x|$ shown in Figure 13.6B is a line that pierces the purported tangent plane, $L(x, y) = 0$, at an angle of about 35 degrees. Thus over the line $y = x$, $L(x, y) = 0$ is not tangent to the graph of F . We do not accept the graph of $L(x, y)$ as tangent to the graph of F . Also, F is not differentiable at $(0,0)$. In this case

$$F_1(x, y) = \frac{1}{2} \sqrt{\frac{|y|}{|x|}} \quad \text{for } x > 0, \quad \text{and} \quad -\frac{1}{2} \sqrt{\frac{|y|}{|x|}} \quad \text{for } x < 0,$$

$$F_1(0, 0) = 0, \quad \text{and} \quad F_1(0, y) \quad \text{does not exist for } y \neq 0$$

F_1 is neither continuous nor even defined throughout the interior of any circle with center $(0,0)$. The conditions of Definition 13.1.3 for a local linear approximation are not met.

Explore 13.1.2 Compute $F_2(x, y)$ for $F(x) = \sqrt{|xy|}$. Is F_2 continuous on the interior of a circle with center $(0,0)$?

Property 13.1.1 A property of tangents to functions of one variable. Suppose f is a function of one variable and at a number a in its domain, $f'(a)$ exists. The graph of $L(x) = f(a) + f'(a)(x - a)$ is the tangent to the graph of f at $(a, f(a))$. Then

$$\begin{aligned} \lim_{x \rightarrow a} \frac{|f(x) - L(x)|}{|x - a|} &= \lim_{x \rightarrow a} \left| \frac{f(x) - f(a) - f'(a)(x - a)}{x - a} \right| \\ &= \left| \lim_{x \rightarrow a} \frac{f(x) - f(a)}{x - a} - f'(a) \right| \\ &= 0. \end{aligned} \tag{13.3}$$

It is sometimes said that the numerator, $f(x) - L(x)$, in $\frac{|f(x) - L(x)|}{|x - a|}$ 'goes to zero faster' than does the denominator, $|x - a|$. *It is this property that is the defining characteristic of 'tangent'.* Only the existence of $f'(a)$ is required. It is not required that $f'(x)$ be continuous.

As was apparent in Figure 13.5B for the function $F(x, y) = \sqrt{|xy|}$, something more than existence of $F_1(a, b)$ and $F_2(a, b)$ is required in order to have a tangent plane for $F(x, y)$ at a point (a, b) . A sufficient condition is that F_1 and F_2 exist and be continuous on a circle with center (a, b) .

Property 13.1.2 A property of local linear approximations to functions of two variables. Suppose F is a function of two variables, (a, b) is a number pair in the domain of F , and F_1 and F_2 exist and are continuous on the interior of a circle with center (a, b) . Then $L(x, y) = F(a, b) + F_1(a, b)(x - a) + F_2(a, b)(y - b)$ is the local linear approximation to F at (a, b) , and

$$\lim_{(x,y) \rightarrow (a,b)} \frac{|F(x, y) - L(x, y)|}{\sqrt{(x - a)^2 + (y - b)^2}} = 0 \tag{13.4}$$

The graph of L is the tangent plane to F at the point $(a, b, F(a, b))$.

The proof of Property 13.1.2 involves some interesting analysis that you can understand, but is long enough that we have not included it. We use this property in proving asymptotic stability of systems of difference equations in Chapter 16.

Exercises for Section 13.1, Partial derivatives of functions of two variables.

Exercise 13.1.1 Draw three dimensional graphs of

- a. $F(x, y) = 2$ b. $F(x, y) = x$
 c. $F(x, y) = x^2$ d. $F(x, y) = (x + y)/2$
 e. $F(x, y) = 0.2x + 0.3y$ f. $F(x, y) = (x^2 + y^2)/4$
 g. $F(x, y) = 0.5xe^{-y}$ h. $F(x, y) = \sin y$
 i. $F(x, y) = 0.5x + \sin y$ j. $F(x, y) = x \sin y$
 k. $F(x, y) = \sqrt{x^2 + y^2}$ l. $F(x, y) = xy$
 m. $F(x, y) = \frac{1}{0.4 + x^2 + y^2}$ n. $F(x, y) = e^{(-x^2 - y^2)}$
 o. $F(x, y) = |xy|$ p. $F(x, y) = \sin(x^2 + y^2)$

Exercise 13.1.2 Find the partial derivatives, F_1 , F_2 , $F_{1,1}$, $F_{1,2}$, $F_{2,1}$ and $F_{2,2}$ of the following functions.

- a. $F(x, y) = 3x - 5y + 7$ b. $F(x, y) = x^2 + 4xy + 3y^2$
 c. $F(x, y) = x^3y^5$ d. $F(x, y) = \sqrt{xy}$
 e. $F(x, y) = \ln(x \cdot y)$ f. $F(x, y) = \frac{x}{y}$
 g. $F(x, y) = e^{x+y}$ h. $F(x, y) = x^2e^{-y}$
 i. $F(x, y) = \sin(2x + 3y)$ j. $F(x, y) = e^{-x} \cos y$

Exercise 13.1.3 Is the plane $z = 0$ a tangent plane to the graph of $F(x, y) = \sqrt{x^2 + y^2}$ shown in Figure 13.2D.

Exercise 13.1.4 Find $F_1(a, b)$ and $F_2(a, b)$ for

- a. $F(x, y) = \frac{x}{1 + y^2}$ $(a, b) = (1, 0)$
 b. $F(x, y) = \sqrt{x^2 + y^2}$ $(a, b) = (1, 2)$
 c. $F(x, y) = e^{-xy}$ $(a, b) = (0, 0)$
 d. $F(x, y) = \sin x \cos y$ $(a, b) = (\pi/2, \pi)$

Exercise 13.1.5 Find the local linear approximation, $L(x, y)$, to $F(x, y)$ at the point (a, b) . For each case, compute

$$\frac{|F(x, y) - L(x, y)|}{\sqrt{(x - a)^2 + (y - b)^2}} \quad \text{for } (x, y) = (a + 0.1, b), \quad \text{and } (x, y) = (a + 0.01, b + 0.01).$$

- a. $F(x, y) = 4x + 7y - 16$ $(a, b) = (3, 2)$
- b. $F(x, y) = xy$ $(a, b) = (2, 1)$
- c. $F(x, y) = \frac{x}{y+1}$ $(a, b) = (1, 0)$
- d. $F(x, y) = xe^{-y}$ $(a, b) = (1, 0)$
- e. $F(x, y) = \sin \pi(x + y)$ $(a, b) = (1/2, 1/4)$

Exercise 13.1.6 For $P = nRT/V$, find $\frac{\partial}{\partial V}P$ and $\frac{\partial}{\partial T}P$. For fixed T , how does P change as V increases? For fixed V , how does P change as T increases?

Exercise 13.1.7 Draw the graph of $F(x, y)$ and the graph of the plane tangent to the graph of F at the point (a, b) . A MATLAB program to solve c. is shown in the answer to this exercise, Exercise 13.1.7.

- a. $F(x, y) = 0.5x + y + 1$ $(a, b) = (0.5, 1)$
- b. $F(x, y) = (x^2 - y^2)/2$ $(a, b) = (1, 1)$
- c. $F(x, y) = (x^2 + y^2)/2$ $(a, b) = (1, 0.5)$
- d. $F(x, y) = e^{xy/2}$ $(a, b) = (1, 0.2)$
- e. $F(x, y) = \sqrt{9 - x^2 - y^2}$ $(a, b) = (1, 0.2)$
- f. $F(x, y) = 4 - x^2 - y^2$ $(a, b) = (1, 0.2)$
- g. $F(x, y) = 2/(1 + x^2 + y^2)$ $(a, b) = (1, 1)$
- h. $F(x, y) = e^{-x^2-y^2} = e^{-x^2} e^{-y^2}$ $(a, b) = (1, 0.5)$

Exercise 13.1.8 Let F be defined by

$$\begin{aligned} F(x, y) &= x^2 & \text{for } y > 0 \\ &= 0 & \text{for } y \leq 0 \end{aligned}$$

- Sketch a graph of F in three dimensional space.
- Is $F_1(x, y)$ continuous on the interior of a circle with center $(0, 0)$?
- Let $L(x, y) = 0$ for all (x, y) . Is it true that

$$\lim_{(x,y) \rightarrow (0,0)} \frac{F(x, y) - L(x, y)}{\sqrt{x^2 + y^2}} = 0 \quad ?$$

- Are you willing to call the plane $z = 0$ a tangent plane to the graph of F ?

13.2 Maxima and minima of functions of two variables.

Figure 13.7B shows a slice of the graph of $F(x, y) = x(1 - x)^2 + y^2(1 - y)$ through $x = 1/3$ and a slice through $y = 2/3$. The point $(1/3, 2/3, 8/27)$ at which these slices intersect appears to be and is a local maximum for F . The two tangents to these slices are horizontal as would be expected at an interior local maximum for a function of a single variable. The point $(1/3, 2/3)$ and associated slices were selected by solving two equations for x and y :

$$F_1(x, y) = 1 - 4x + 3x^2 = 0$$

$$F_2(x, y) = 2y - 3y^2 = 0.$$

There are four solutions, called *critical points* of F ,

$$(x, y) = (1/3, 2/3), \quad (x, y) = (1/3, 0), \quad (x, y) = (1, 2/3) \quad \text{and} \quad (x, y) = (1, 0).$$

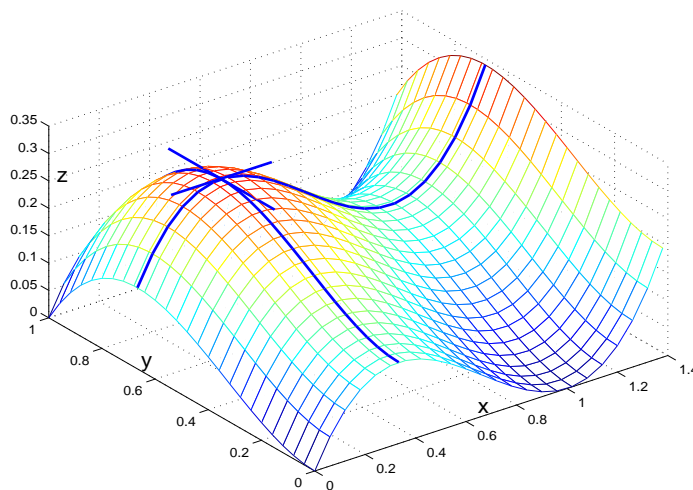

Figure 13.7: Slices through the graph of $F(x, y) = x(1 - x)^2 + y^2(1 - y)$ through $x = 1/3$ and $y = 2/3$. $(1/3, 2/3, 8/27)$ is a local maximum of F .

Definition 13.2.1 Critical points. A point (a, b) of the domain D of a function of two variables, F , is an *interior point* of the domain if there is a circle centered at (a, b) whose interior is a subset of D . Points of D that are not interior points are called *boundary points* of D .

An interior point (a, b) of F is a *critical point* of F means that

$$F_1(a, b) = 0 \quad \text{and} \quad F_2(a, b) = 0$$

or that one of $F_1(a, b)$ or $F_2(a, b)$ fails to exist.

Boundary points of D are also critical points of F .

There are four critical points of $F(x, y) = x(1 - x)^2 + y^2(1 - y)$,

$$(1/3, 2/3), \quad (1, 2/3), \quad (1/3, 0), \quad \text{and} \quad (1, 0).$$

The critical point $(1/3, 2/3)$ is discussed above and shown in Figure 13.7.

The critical point $(1, 2/3)$ is illustrated in Figure 13.8 and is neither a high point nor a low point, it is a *saddle* point. The surface is convex upward in the x -direction and is concave downward in the y -direction. The tangent at $(1, 2/3, 4/27)$ parallel to the y -axis is above the surface; the tangent parallel to the x -axis is below the surface and would normally not be visible.

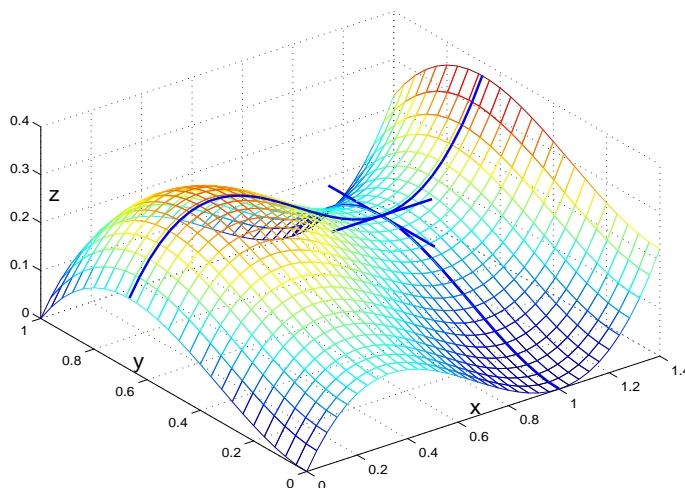

Figure 13.8: Slices through the graph of $F(x, y) = x^2(1 - x) + y(1 - y)^2$ through $x = 1$ and $y = 2/3$. $(1, 2/3, 4/27)$ is a saddle point of F .

The critical point $(1, 0)$ is illustrated in Figure 13.9 and is a local minimum for F and is illustrated in Figure 13.9. The domain for y is $[-0.4, 1]$; in Figures 13.7 and 13.8 the domain for x is $[0, 1]$. Also the viewpoint is lower in Figure 13.9 than in Figures 13.7 and 13.8 in order to look underneath the graph at the low point.

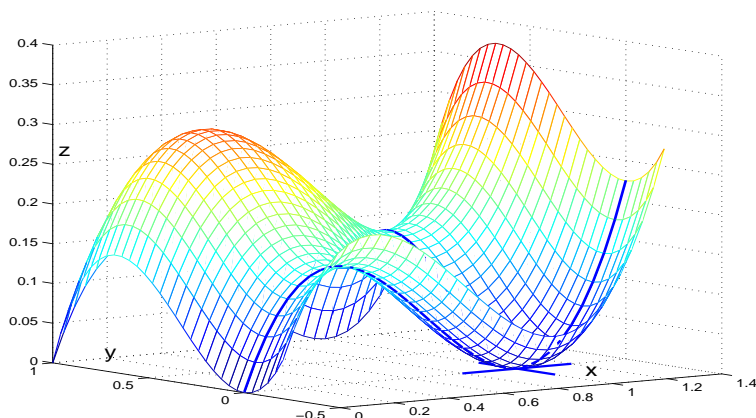

Figure 13.9: Slices through the graph of $F(x, y) = x(1 - x)^2 + y^2(1 - y)$ through $x = 1$ and $y = 0$. $(1, 0, 0)$ is a local minimum of F .

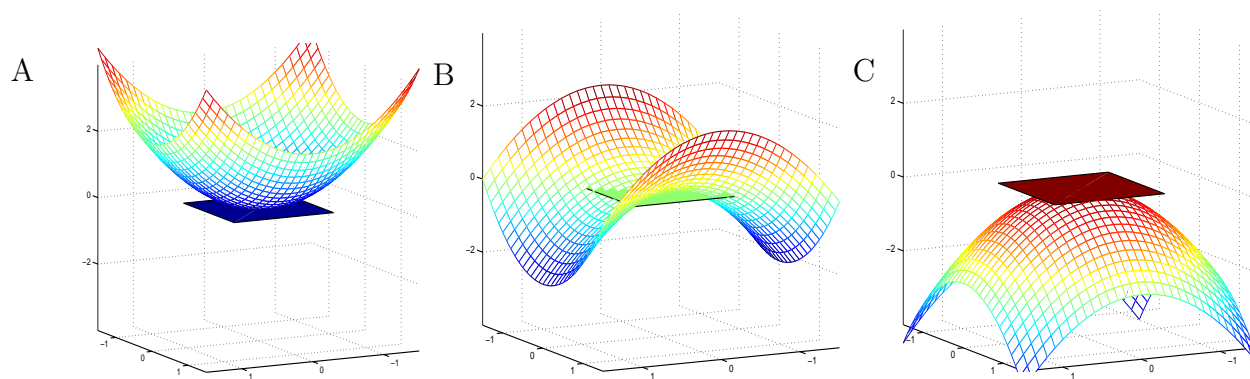

Figure 13.10: Graphs of A. $z = x^2 + y^2$, B. $z = x^2 - y^2$, and C. $z = -x^2 - y^2$. The local linear approximation to each is the horizontal plane $z = 0$.

Explore 13.2.1 Locate the critical point $(1/3, 0)$ of $F(x, y) = x(1 - x)^2 + y^2(1 - y)$ in Figure 13.9 and classify it as a local maximum, local minimum or saddle point. ■

Example 13.2.1 The graphs of $F(x, y) = x^2 + y^2$, $G(x, y) = x^2 - y^2$ and $H(x, y) = -x^2 - y^2$ shown in Figure 13.10 illustrate three important options. The origin, $(0, 0)$, is a critical point of each of the graphs and the $z = 0$ plane is the tangent plane to each of the graphs at $(0, 0)$. For F , for example,

$$\begin{aligned} F(x, y) &= x^2 + y^2 & F_1(x, y) &= 2x & F_2(x, y) &= 2y \\ F(0, 0) &= 0 & F_1(0, 0) &= 0 & F_2(0, 0) &= 0 \end{aligned}$$

The origin, $(0, 0)$, is a critical point of F , the linear approximation to F at $(0, 0)$ is $L(x, y) = 0$, and the tangent plane is $z = 0$, or the x, y plane. The same is true for G and H ; the tangent plane at $(0, 0, 0)$ is $z = 0$ for all three examples. This seemingly monotonous information is saved by the observations of the relation of the tangent plane to the graphs of the three functions. For F , $(0, 0, 0)$ is the lowest point of the graph of F , and for H , $(0, 0, 0)$ is the highest point of the graph of H . This is similar to the horizontal lines associated with high and low points of graphs of functions of one variables. The graph of G is different. The point $(0, 0, 0)$ is called a saddle point of the graph of G . The portion of G in the x, z plane ($y = 0$) has a low point at $(0, 0, 0)$ and the portion of G in the y, z plane ($x = 0$) has a high point at $(0, 0, 0)$.

For a function f of a single variable and a number a for which $f'(a) = 0$, there is a simple second derivative test, Theorem 9.2.3, that distinguishes whether $(a, f(a))$ is a locally high point ($f''(a) < 0$) or a locally low point ($f''(a) > 0$). There is also a second derivative test for functions of two variables.

Definition 13.2.2 Definition of Local Maxima and Minima. If (a, b) is a point in the domain of a function F of two variables, $F(a, b)$ is a local maximum for F means that there is a number $\delta_0 > 0$ such that if (x, y) is in the domain of F and $\sqrt{(x - a)^2 + (y - b)^2} < \delta_0$ then $F(x, y) \leq F(a, b)$.

The definition of local minimum is similar.

Theorem 13.2.1 Local Maxima and Minima of functions of two variables.

Suppose (a, b) is a critical point of a function F of two variables that has continuous first and second partial derivatives in a circle with center at (a, b) and

$$\Delta = F_{1,1}(a, b)F_{2,2}(a, b) - (F_{1,2}(a, b))^2.$$

Case 1. If $\Delta > 0$ and $F_{1,1}(a, b) > 0$ then $F(a, b)$ is a local minimum of F .

Case 2. If $\Delta > 0$ and $F_{1,1}(a, b) < 0$ then $F(a, b)$ is a local maximum of F .

Case 3. If $\Delta < 0$ then $(a, b, F(a, b))$ is a saddle point of F .

Case 4. If $\Delta = 0$, punt, use another supplier.

We omit the proof of Theorem 13.2.1, but illustrate its application to the functions F , G , and H of Example 13.2.1 and shown in Figure 13.10.

$$\text{For } F(x, y) = x^2 + y^2, \quad \Delta = 2 \times 2 - 0 = 4 > 0, \quad F_{1,1}(0, 0) = 2 > 0,$$

and the origin is a local minimum for F .

$$\text{For } G(x, y) = x^2 - y^2, \quad \Delta(0, 0) = 2(-2) - 0 = -4 < 0,$$

and the origin is a saddle point for G . We have not defined a saddle point. For our purposes, a saddle point is a critical point for which $\Delta < 0$.

$$\text{For } H(x, y) = -x^2 - y^2, \quad \Delta = -2(-2) - 0 = 4 > 0, \quad H_{1,1}(0, 0) = -2,$$

and the origin is a local maximum for H .

Example 13.2.2 Least squares fit of a line to data. A two variables minimization problem crucial to the sciences is the fit of a linear function to data.

Problem. Given points $(x_1, y_1), (x_2, y_2), \dots, (x_n, y_n)$, where $x_i \neq x_j$ if $i \neq j$, find numbers a_0 and b_0 so that $(a, b) = (a_0, b_0)$ minimizes

$$SS(a, b) = \sum_{k=1}^n (y_k - a - bx_k)^2 \tag{13.5}$$

In Figure 13.2.2.2, $SS(a, b)$ is the sum of the squares of the lengths of the dashed lines.

Figure for Example 13.2.2.2 A graph of data and a line. $SS(a, b)$ is the sum of the squares of the lengths of the dashed lines.

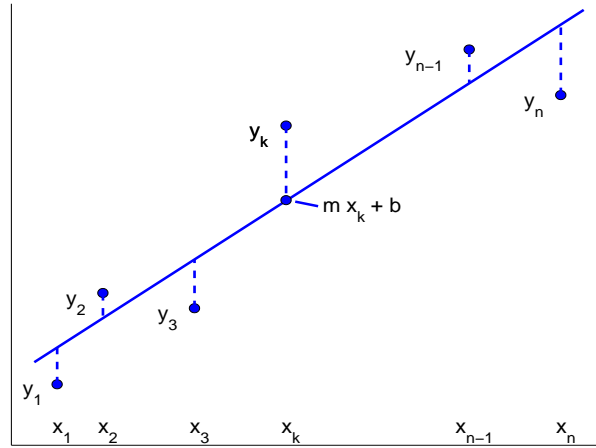

Solution. The critical points of SS are the solutions to the equations

$$SS_1(a, b) = \frac{\partial}{\partial a} SS = 0 \quad SS_2(a, b) = \frac{\partial}{\partial b} SS = 0. \quad (13.6)$$

$$\begin{aligned} SS_1(a, b) &= \frac{\partial}{\partial a} \left[\sum_{k=1}^n (y_k - a - bx_k)^2 \right] \\ &= \sum_{k=1}^n \frac{\partial}{\partial a} (y_k - a - bx_k)^2 \\ &= \sum_{k=1}^n 2(y_k - a - bx_k)(-1) \\ &= 2 \sum_{k=1}^n (a + bx_k - y_k) \\ &= 2 \left(a \sum_{k=1}^n 1 + b \sum_{k=1}^n x_k - \sum_{k=1}^n y_k \right) \end{aligned}$$

$$\begin{aligned} SS_2(a, b) &= \frac{\partial}{\partial b} \left[\sum_{k=1}^n (y_k - a - bx_k)^2 \right] \\ &= \sum_{k=1}^n \frac{\partial}{\partial b} (y_k - a - bx_k)^2 \\ &= \sum_{k=1}^n 2(y_k - a - bx_k)(-x_k) \\ &= 2 \sum_{k=1}^n (ax_k + bx_k^2 - x_k y_k) \\ &= 2 \left(a \sum_{k=1}^n x_k + b \sum_{k=1}^n x_k^2 - \sum_{k=1}^n x_k y_k \right) \end{aligned}$$

Imposing the conditions $SS_1(a, b) = 0$ and $SS_2(a, b) = 0$ and simplifying leads to the *Normal Equations*:

$$\begin{aligned} a n + b \sum_{k=1}^n x_k &= \sum_{k=1}^n y_k \\ a \sum_{k=1}^n x_k + b \sum_{k=1}^n x_k^2 &= \sum_{k=1}^n x_k y_k \end{aligned} \quad (13.7)$$

Some notation is useful:

$$S_x = \sum_{k=1}^n x_k, \quad S_y = \sum_{k=1}^n y_k, \quad S_{xx} = \sum_{k=1}^n x_k^2, \quad S_{xy} = \sum_{k=1}^n x_k y_k, \quad S_{yy} = \sum_{k=1}^n y_k^2.$$

The solution to the Normal Equations 13.7 is

$$\begin{aligned} a_0 &= \frac{S_{xx} S_y - S_x S_{xy}}{\Delta} \\ b_0 &= \frac{n S_{xy} - S_x S_y}{\Delta} \\ \Delta &= n S_{xx} - (S_x)^2 \end{aligned} \tag{13.8}$$

It is important that $\Delta \neq 0$. The proof that Δ is actually positive involves some clever and not very intuitive algebra. Form the sum

$$S = \sum_{k=1}^n (S_{xx} - S_x x_k)^2.$$

Because the x_k are distinct, at least one of $S_{xx} - S_x x_k \neq 0$ and $S > 0$.

$$\begin{aligned} S &= \sum_{k=1}^n (S_{xx} - S_x x_k)^2 \\ &= \sum_{k=1}^n ((S_{xx})^2 - 2S_{xx} S_x x_k + (S_x)^2 x_k^2) \\ &= \sum_{k=1}^n (S_{xx})^2 - 2S_{xx} S_x \sum_{k=1}^n x_k + (S_x)^2 \sum_{k=1}^n x_k^2 \\ &= n(S_{xx})^2 - 2S_{xx} S_x S_x + (S_x)^2 S_{xx} \\ &= S_{xx}(nS_{xx} - (S_x)^2) \\ &= S_{xx} \Delta \end{aligned}$$

Now $S_{xx} > 0$ and $S = S_{xx} \Delta > 0$, so $\Delta > 0$.

Explore 13.2.2 Why is S_{xx} positive? ■

Example 13.2.3 Fit a line to the data in Example Figure 13.2.3.3.

Figure for Example 13.2.3.3 Data, a graph of the data and a line $y = a + bx$ fit to the data:

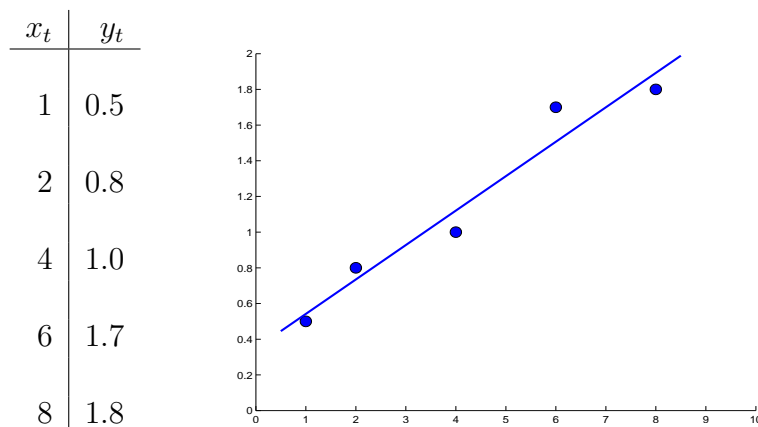

$$\begin{aligned}
 S_x &= 1 + 2 + 4 + 6 + 8 = 21, \\
 S_y &= 0.5 + 0.8 + 1.0 + 1.7 + 1.8 = 5.8 \\
 S_{xx} &= 1^2 + 2^2 + 4^2 + 6^2 + 8^2 = 121, \\
 S_{xy} &= 1 \cdot 0.5 + 2 \cdot 0.8 + 4 \cdot 1.0 + 6 \cdot 1.7 + 8 \cdot 1.8 = 30.7
 \end{aligned}$$

$$\begin{aligned}
 \Delta &= nS_{xx} - (S_x)^2 = 5 \cdot 121 - (21)^2 = 164 \\
 a &= (S_{xx} S_y - S_x S_{xy})/\Delta = (121 \cdot 5.8 - 21 \cdot 30.7)/164 = 0.348 \\
 b &= (nS_{xy} - S_x S_y)/\Delta = (5 \cdot 30.7 - 21 \cdot 5.8)/164 = 0.193
 \end{aligned}$$

The line $y = 0.348 + 0.193x$ is the closest to the data in the sense of least squares and is drawn in Example Figure 13.2.3.3.

You would systematically organize the arithmetic if you fit very many lines to data as we just did. Better than that, the following MATLAB commands do the same task for the data in Example Figure 13.2.3.3.

```

close all;clc;clear
x=[1 2 4 6 8]; y=[0.5 0.8 1.0 1.7 1.8];
P=polyfit(x,y,1)
xp=[0.5 8.5]; yp=polyval(P,xp);
plot(x,y,'o','linewidth',2)
hold('on')
plot(xp,yp,'linewidth',2)
    
```

Furthermore, there are many programmable hand calculators that will do this task. What is required is that you load the data in two vectors or lists, find the coefficients of the line closest (in the least squares sense) to the data, plot the data and plot the line.

Example 13.2.4 Problem: Find the dimensions of the largest box (rectangular solid) that will fit in a hemisphere of radius R .

Solution. Assume the hemisphere is the graph of $z = \sqrt{R^2 - x^2 - y^2}$ and that the optimum box has one face in the x, y -plane and the other four corners on the hemisphere (see Figure 13.2.4.4).

Figure for Example 13.2.4.4 A. A box in a hemisphere. One corner of the box is at (x, y) in the x, y -plane. B. Graph of $W(x, y) = \max(0, x^2 y^2 (1 - x^2 - y^2))$.

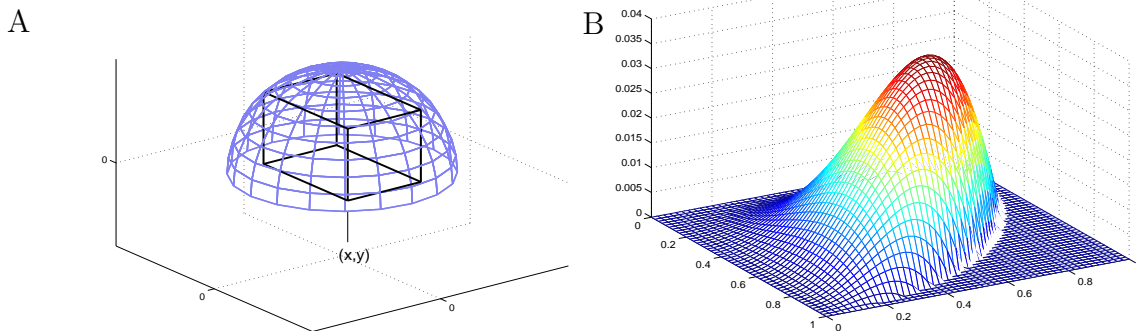

The volume, V of the box is

$$V(x, y) = 2x \times 2y \times z = 4xy \sqrt{R^2 - x^2 - y^2}$$

Before launching into partial differentiation, it is perhaps clever, and certainly useful, to observe that the values of x and y for which V is a maximum are also the values for which $V^2/16$ is a maximum.

$$\frac{V^2(x, y)}{16} = W(x, y) = \frac{16x^2y^2(R^2 - x^2 - y^2)}{16} = R^2x^2y^2 - x^4y^2 - x^2y^4.$$

It is easier to analyze $W(x, y)$ than it is to analyze $V(x, y)$.

$$\begin{aligned} W_1(x, y) &= 2R^2xy^2 - 4x^3y^2 - 2xy^4 \\ &= 2xy^2(R^2 - 4x^2 - 2y^2) \end{aligned}$$

$$\begin{aligned} W_2(x, y) &= 2R^2x^2y - 2x^4y^2 - 4x^2y^3 \\ &= 2x^2y(R^2 - 2x^2 - 4y^2) \end{aligned}$$

Solving for $W_1(x, y) = 0$ and $W_2(x, y) = 0$ yields $x = R/\sqrt{3}$ and $y = R/\sqrt{3}$, for which $z = R/\sqrt{3}$. The dimensions of the box are $2R/\sqrt{3}$, $2R/\sqrt{3}$, and $R/\sqrt{3}$.

Explore 13.2.3 Are there some critical points of W other than $(R/\sqrt{3}, R/\sqrt{3}, R/\sqrt{3})$? ■

Example 13.2.5 Warning: Obnubilation Zone. *Problem.* Find the point of the ellipsoid

$$\frac{x^2}{1} + \frac{y^2}{4} + \frac{z^2}{9} = 1 \quad \text{that is closest to} \quad (-2, 3, -1) \tag{13.9}$$

See Example Figure 13.2.5.5

Figure for Example 13.2.5.5 The ellipsoid $x^2/1 + y^2/4 + z^2/9 = 1$ and a line from $(-2, 3, -1)$ to a point (x, y, z) of the ellipsoid.

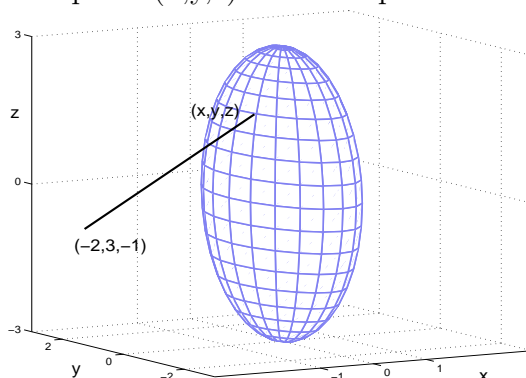

Solution. Claim without proof: The point (x, y, z) of the ellipsoid that is closest to $(-2, 3, -1)$ will have negative x , positive y , and negative z coordinates.

The distance between (a, b, c) and (p, q, r) in 3-dimensional space is

$$\sqrt{(p - a)^2 + (q - b)^2 + (r - c)^2}.$$

The distance from $(-2, 3, -1)$ to (x, y, z) on the ellipsoid is

$$D(x, y, z) = \sqrt{(x + 2)^2 + (y - 3)^2 + (z + 1)^2}$$

We solve for z in Equation 13.9 and write

$$z = -3\sqrt{1 - x^2 - y^2/4} \quad z \text{ is negative.} \quad (13.10)$$

$$E(x, y) = \sqrt{(x+2)^2 + (y-3)^2 + (1 - 3\sqrt{1 - x^2 - y^2/4})^2} \quad (13.11)$$

Define $F(x, y) = (E(x, y))^2$ and write

$$\begin{aligned} F(x, y) &= (x+2)^2 + (y-3)^2 + \left(1 - 3\sqrt{1 - x^2 - y^2/4}\right)^2 \\ F_1(x, y) &= 2(x+2) + 2\left(1 - 3\sqrt{1 - x^2 - y^2/4}\right) \frac{\partial}{\partial x} \left(1 - 3\sqrt{1 - x^2 - y^2/4}\right) \\ &= 2(x+2) + 2\left(1 - 3\sqrt{1 - x^2 - y^2/4}\right) \frac{(-3)(-2x)}{2\sqrt{1 - x^2 - y^2/4}} \\ F_2(x, y) &= 2(y-3) + 2\left(1 + 3\sqrt{1 - x^2 - y^2/4}\right) \frac{3(-2y/4)}{2\sqrt{1 - x^2 - y^2/4}} \end{aligned}$$

Now we have a mess. We need to (and can!) solve for (x, y) in

$$\begin{aligned} F_1(x, y) &= 2(x+2) + 6x \left(\frac{1}{\sqrt{1 - x^2 - y^2/4}} - 3 \right) = 0 \\ F_2(x, y) &= 2(y-3) + \frac{6y}{4} \left(\frac{1}{\sqrt{1 - x^2 - y^2/4}} - 3 \right) = 0 \end{aligned}$$

First we write

$$\begin{aligned} 2(x+2) &= -6x \left(\frac{1}{\sqrt{1 - x^2 - y^2/4}} - 3 \right) \\ 2(y-3) &= -\frac{6y}{4} \left(\frac{1}{\sqrt{1 - x^2 - y^2/4}} - 3 \right), \end{aligned} \quad (13.12)$$

divide corresponding sides of the two equations, and find that

$$y = \frac{12x}{3x-2}. \quad (13.13)$$

Substitute this expression for y in Equation 13.12, simplify, and find that

$$8x - 2 = \frac{\mp 3x(3x-2)}{\sqrt{(1-x^2)(9x^2-12x+4)} - 36x^2}$$

Square both sides of this equation and clear fractions.

$$(8x-2)^2 \left[(1-x^2)(9x^2-12x+4) - 36x^2 \right] = 9x^2(9x^2-12x+4)$$

Multiply and collect.

$$576x^6 - 1056x^5 + 2485x^4 - 380x^3 - 480x^2 + 176x - 16 = 0 \quad (13.14)$$

Now we have it! In MATLAB issue the two commands,

```
format long      and      roots([576 -1056 2485 -380 -480 176 -16])
```

The output will be

```
0.793717568921366 + 1.862187416061669i
0.793717568921366 - 1.862187416061669i
-0.482870021732987
0.281691271346906 + 0.074391358359997i
0.281691271346906 - 0.074391358359997i
0.165385674529775
```

Many programable hand calculators have polynomial root solving capabilities also.

There are two real roots, -0.482870021732987 and 0.165385674529775 . Use $x = 0.165385674529775$ and compute $y = 1.680224831$ and $z = -0.726205610$ from Equations 13.13 and 13.10, and the distance from $(-2,3,-1)$ to the ellipsoid is 2.029. **Whew!**

Explore 13.2.4 For the algebraically strong, fill in the algebra omitted in Example 13.2.5

Exercises for Section 13.2 Maxima and minima of functions of two variables.

Exercise 13.2.1 Find the critical points, if any, of F .

- | | | | |
|----|--------------------------------|----|------------------------------|
| a. | $F(x, y) = 2x + 5y + 7$ | b. | $F(x, y) = x^2 + 4xy + 3y^2$ |
| c. | $F(x, y) = x^3(1 - x) + y$ | d. | $F(x, y) = xy(1 - xy)$ |
| e. | $F(x, y) = (x - x^2)(y - y^2)$ | f. | $F(x, y) = \frac{x}{y}$ |
| g. | $F(x, y) = e^{x+y}$ | h. | $F(x, y) = \sin(x + y)$ |
| i. | $F(x, y) = \frac{x^2}{1+y^2}$ | j. | $F(x, y) = \cos x \sin y$ |

Exercise 13.2.2 For each of the following functions, find the critical points and use Theorem 13.2.1 to determine whether they are local maxima, local minima, or saddle points or none of these.

- | | |
|----|---|
| a. | $F(x, y) = -x^2 + xy - y^2$ |
| b. | $F(x, y) = x^2 + xy - y^2$ |
| c. | $F(x, y) = x^2 + y^2 - 2xy + 2x - 2y$ |
| d. | $F(x, y) = -x^2 - 5y^2 + 2xy - 10x + 6y + 20$ |

Exercise 13.2.3 Find C and b so that Ce^{bx} closely approximates the data

x	0	1	2	3	4
y	2.18	5.98	16.1	43.6	129.7

Observe that for $y = Ce^{bx}$, $\ln y = \ln C + bx$. Therefore, fit $a + bx$ to the number pairs, $(x, \ln y)$ using linear least squares. Then $\ln y_k \doteq a + bx_k$, and

$$y_k \doteq e^{a+bx_k} = e^a \cdot e^{bx_k} = Ce^{bx_k}, \quad \text{where } C = e^a.$$

Exercise 13.2.4 a. Find a , b , and c so that $y = a + bx + cx^2$ is the least squares approximation to data, $(x_1, y_1), (x_2, y_2), \dots, (x_n, y_n)$. To do so you will need to minimize

$$SS = \sum_{k=1}^n \left(y_k - (a + bx_k + cx_k^2) \right)^2.$$

This is a three-variable minimization problem. The solution will be similar to the least squares line approximation to data of Example 13.2.2. b. In Exercise Table 13.2.4 are data showing the height of a ball falling in air above a Texas Instruments CBL motion detector. Find the parabola that is the least squares fit to the data.

c. Check your answer on a computer or calculator.

Table for Exercise 13.2.4 Height of a ball falling in aire above a Texas Instruments CBL motion detector.

Time _{<i>i</i>} sec	0.232	0.333	0.435	0.537	0.638	0.739	0.840
Position _{<i>i</i>} cm	245.9	235.8	214.3	184.1	146.0	99.3	45.5

Exercise 13.2.5 Find a and b so that $\sin(ax + b)$ closely approximates the data

x	0	1	2	3	4
y	0.97	0.70	0.26	-0.26	-0.5

Observe that for $y = \sin(ax + b)$, $\arcsin y = ax + b$. Therefore, fit $ax + b$ to the number pairs, $(x, \arcsin y)$ using linear least squares.

Exercise 13.2.6 Interpret the real root $x = 0.165385675$ of Equation 13.14 related to the ellipsoid example.

Exercise 13.2.7 Find the largest box that will fit in the positive octant ($x \geq 0$, $y \geq 0$, and $z \geq 0$) and underneath the plane $z = 12 - 2x - 3y$.

Exercise 13.2.8 Find the largest box that will fit in the positive octant and underneath the hemisphere $z = \sqrt{25 - x^2 - y^2}$.

Exercise 13.2.9 Find the point of the plane $z = 2x + 3y - 12$ that is

1. closest to the origin.
2. closest to (4,5,6)

Exercise 13.2.10 Find the point of the sphere $x^2 + y^2 + z^2 = 25$ that is closest to (3,4,5).

Exercise 13.2.11 Find the point of the ellipsoid of Equation 13.9

$$\frac{x^2}{1} + \frac{y^2}{4} + \frac{z^2}{9} = 1 \quad \text{that is farthest from} \quad (-2, 3, -1) \quad (13.15)$$

Exercise 13.2.12 In Exercise 8.3.3¹ we found that the average power over a whole cycle of a bounding flight of a bird should be

$$\bar{P} = (1 - x)P_{\text{folded}} + xP_{\text{flapping}} = A_b u^3 + xA_w u^3 + B \frac{m^2 g^2}{xu}$$

where A_b and $A_b + A_w$ are, respectively, drag coefficients of the bird without wings extended and with wings extended and flapping, B is a constant, u is the speed of flight, m is the mass of the bird, g is the acceleration of gravity, and x is the fraction of a flight cycle during which the wings are flapping. You were to find the fraction, x , for which the required power is a minimum and the fraction, x , for which the required energy is a minimum, with $E = \bar{P}/u$. You may have found that $x = \sqrt{A_w/Bmg/u^2}$ for both answers.

Find, if there is one, the combination of flight speed, u , and fraction x for which the power \bar{P} is a minimum.

Find, if there is one, the combination of flight speed, u , and fraction x for which the energy E is a minimum.

13.3 Integrals of functions of two variables.

Suppose $F(x, y)$ is a positive function of two variables defined on a region R of the x, y -plane. What is the volume, V , of the region above the x, y -plane and below the graph of $z = F(x, y)$? (Figure 13.11A.)

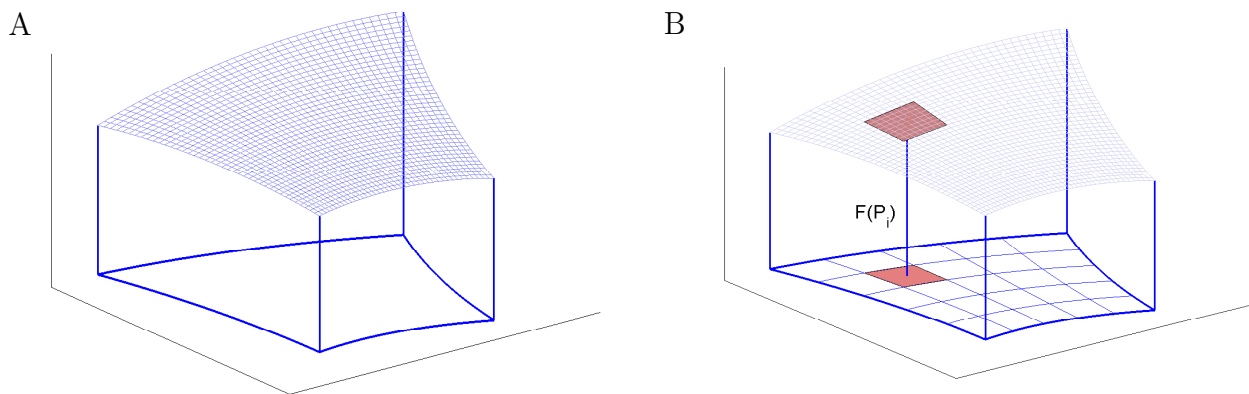

Figure 13.11: A. Graph of a function F of two variables and the region between the graph and the x, y -plane. B. The domain of F is partitioned into small regions.

The volume can be approximated as follows. (Figure 13.11)

Step 1. Choose a positive number δ and partition R into regions R_1, R_2, \dots, R_n of diameter less than δ .

¹Analysis based on R. McNeill Alexander, "Optima for Animals" Princeton University Press, Princeton, NJ, 1996, Section 3.1, pp 45-48.

Step 2. Let P_i be a point in R_i , $i = 1, \dots, n$, and let A_i be the area of R_i .

Step 3. Then

$$V \doteq \sum_{i=1}^n F(P_i) A_i \tag{13.16}$$

The approximation 13.16 converges to V as $\delta \rightarrow 0$.

The graph of $F(x, y) = (\sin \pi x) (\cos \frac{\pi}{2} y)$ is shown in Figure 13.12 with the domain $0 \leq x \leq 1$, $0 \leq y \leq 1$ partitioned into 25 squares of sides 0.2 and a point marked at the center of each square. The volume of the region below the graph of F and above the x, y -plane is approximately

$$\sum_{i=0}^4 \sum_{j=0}^4 \sin((0.1 + i \cdot 0.2) \cdot \pi) \cos((0.1 + j \cdot 0.2) \cdot (\pi/2)) \times 0.2 \times 0.2 \doteq 0.414$$

Similar computations with 100 squares of sides 0.1 yields 0.407 as the approximate volume and with 400 squares of sides 0.05 yields 0.406.

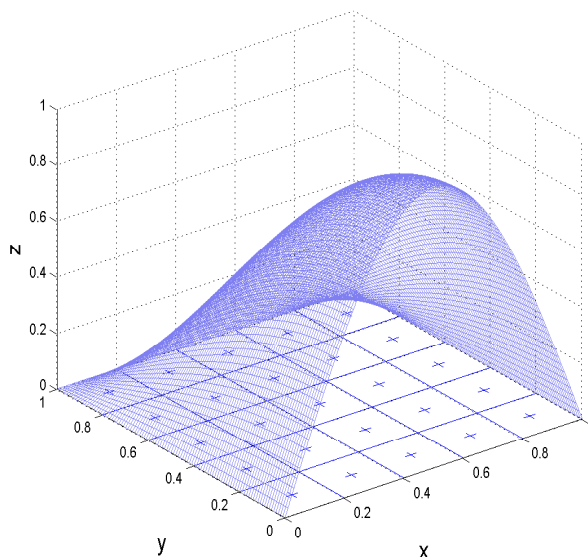

Figure 13.12: The graph of $F(x, y) = (\sin \pi x) (\cos \frac{\pi}{2} y)$ on $0 \leq x \leq 1$, $0 \leq y \leq 1$. The domain is partitioned into squares and the center point of each square is marked.

The sum in Equation 13.16 has other applications than approximating volumes and the following definition is made.

Definition 13.3.1 Integral of a function of two variables. Suppose F is a continuous function defined on a region R of the x, y -plane. The integral of F on R is denoted and defined by

$$\int_R \int F(P) dA = \lim_{\delta \rightarrow 0} \sum_{i=1}^n F(P_i) A_i \tag{13.17}$$

where δ , n , P_i and A_i are as in Steps 1 and 2 above.

The word "region" has been used without definition and ambiguously. We have written of regions in three dimensional space below the graph of a function of two variables and regions in the x, y -plane. We could write "3d-region" and "2d-region" to clarify at least the context. If you approximate the integral of a function of two variables, you are well advised to choose "simple" regions in the x, y -plane whose areas are easily computed. Rectangles plus their interior are good. In Example 13.3.2 we use sectors of annular rings which are polar coordinate "rectangles." We rely on your good will to use the word "region" ambiguously and without formal definition.

Suppose now that R is the region in the x, y -plane between the graphs of two functions f and g of a single variable defined on an interval $[a, b]$ as shown in Figure 13.13A. (R is the set to which (x, y) belongs only if $a \leq x \leq b$ and $f(x) \leq y \leq g(x)$).

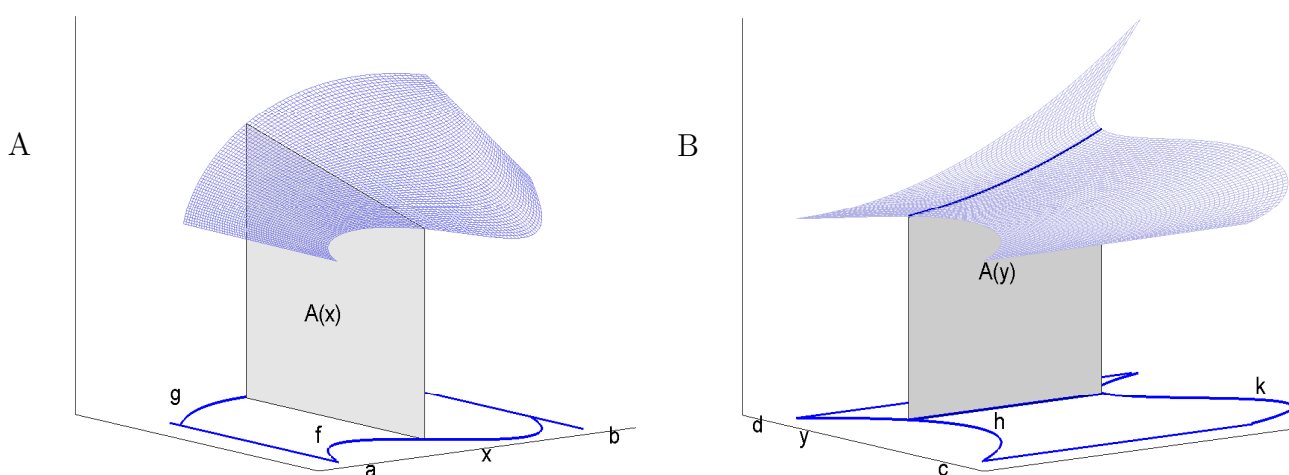

Figure 13.13: A. The domain of F is the set of (x, y) for which $a \leq x \leq b$ and $f(x) \leq y \leq g(x)$. B. The domain of F is the set of (x, y) for which $c \leq y \leq d$ and $h(y) \leq x \leq k(y)$.

Then for each number x in $[a, b]$ the area of the cross section through V at x is

$$A(x) = \int_{f(x)}^{g(x)} F(x, y) dy$$

Using the volume equation 11.2, the volume V is

$$V = \int_a^b A(x) dx = \int_a^b \left(\int_{f(x)}^{g(x)} F(x, y) dy \right) dx$$

Alternatively, Figure 13.13B, there may be two functions $h(y)$ and $k(y)$ defined on an interval $[c, d]$ and R is the region to which (x, y) belongs only if $c \leq y \leq d$ and $h(y) \leq x \leq k(y)$. Then

$$V = \int_c^d \left(\int_{h(y)}^{k(y)} F(x, y) dx \right) dy$$

More generally, two ways to compute the integral of $F(P)$ are

$$\int_R \int F(P) dA = \int_a^b \int_{f(x)}^{g(x)} F(x, y) dy dx \tag{13.18}$$

and

$$\int_R \int F(P) dA = \int_c^d \int_{h(y)}^{k(y)} F(x, y) dx dy. \tag{13.19}$$

In the 'inside' integration $\int_{f(x)}^{g(x)} F(x, y) dy$ of Equation 13.18, x is a constant, the integration is with respect to the variable y . Similarly, in the integration $\int_{h(y)}^{k(y)} F(x, y) dx$ of Equation 13.19, y is a constant, the integration is with respect to the variable x .

Example 13.3.1 The domain of the function $F(x, y) = (\sin \pi x) (\cos \frac{\pi}{2}y)$ shown in Figure 13.12 is $0 \leq x \leq 1, 0 \leq y \leq 1$. Choose $f(x) = 0$ and $g(x) = 1$, for $0 \leq x \leq 1$. The volume of the region below the graph of F is

$$\begin{aligned} \int_0^1 \int_0^1 (\sin \pi x) (\cos \frac{\pi}{2}y) dy dx &= \int_0^1 \left[(\sin \pi x) (\sin \frac{\pi}{2}y) \times \frac{2}{\pi} \right]_{y=0}^{y=1} dx \\ &= \frac{2}{\pi} \int_0^1 \sin \pi x dx \\ &= \frac{2}{\pi} \cdot \frac{2}{\pi} \doteq 0.405285 \quad \blacksquare \end{aligned}$$

Problem. Find the volume, V , of the three dimensional region below the graph of $z = 1 + 2x/3 + y/3$ and above the triangle bounded by $x = 1, y = 1$ and $x + y = 4$. (Figure 13.14.)

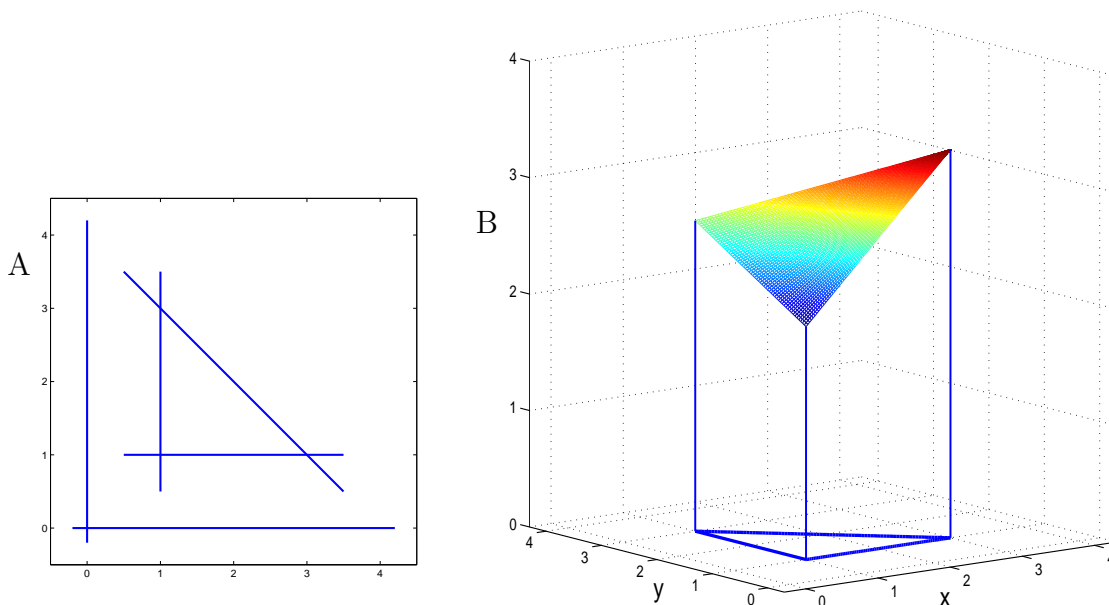

Figure 13.14: A. The region, R , bounded by the graphs of $x = 1, y = 1$, and $x + y = 4$. B. The three-dimensional region above R and below the graph of $z = 1 + 2x/3 + y/3$.

Solution. Define $f(x) = 1$ and $g(x) = 4 - x$ for $1 \leq x \leq 3$.

$$\begin{aligned} V &= \int_1^3 \int_1^{4-x} (1 + 2x/3 + y/3) dy dx \\ &= \int_1^3 \left[y + (2x/3)y + \frac{y^2}{6} \right]_{y=1}^{y=4-x} dx \\ &= \int_1^3 \left((4-x) + (2x/3)(4-x) + \frac{(4-x)^2}{6} - (1 + (2x)/3 - \frac{1}{6}) \right) dx \\ &= \int_1^3 \left(\frac{11}{2} - \frac{1}{3}x - \frac{1}{2}x^2 \right) dx \\ &= \left[\frac{11}{2}x - \frac{1}{6}x^2 - \frac{1}{6}x^3 \right]_1^3 = 5\frac{1}{3} \end{aligned}$$

Problem. Find the volume, V , of the three dimensional region below the graph of $z = 1 - xy$ and above two dimensional region R bounded by $y = -\sqrt{x}$, $y = \sqrt{x}$ and $x = 1$.

Solution 1. Define $f(x) = -\sqrt{x}$ and $g(x) = \sqrt{x}$ for $0 \leq x \leq 1$. (Figure 13.15A.)

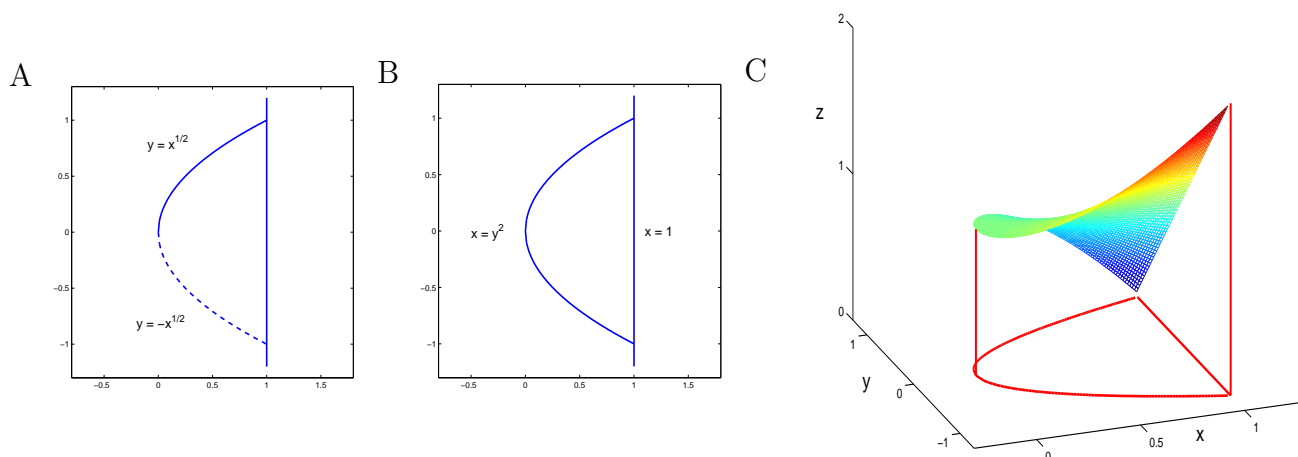

Figure 13.15: A. The region can be defined by $0 \leq x \leq 1$, $-\sqrt{x} \leq y \leq \sqrt{x}$ or B. by $-1 \leq y \leq 1$, $y^2 \leq x \leq 1$.

$$\begin{aligned} V &= \int_0^1 \int_{-\sqrt{x}}^{\sqrt{x}} (1 - xy) dy dx \\ &= \int_0^1 \left[y + x \frac{y^2}{2} \right]_{y=-\sqrt{x}}^{y=\sqrt{x}} dx = \int_0^1 2\sqrt{x} dx \\ &= 2 \frac{x^{3/2}}{3/2} \Big|_0^1 = \frac{4}{3} \end{aligned}$$

Solution 2. The region R is also bounded by $x = y^2$ and $x = 1$, and can be defined by

$y^2 \leq x \leq 1$ for $-1 \leq y \leq 1$. (Figure 13.15B.) Then

$$\begin{aligned} V &= \int_{-1}^1 \int_{y^2}^1 (1 - xy) \, dx \, dy \\ &= \int_{-1}^1 \left[x - \frac{x^2 y}{2} \right]_{x=y^2}^{x=1} \, dy \\ &= \int_{-1}^1 \left(\left(1 - \frac{y}{2}\right) - \left(y^2 - \frac{y^5}{2}\right) \right) \, dy \\ &= \int_{-1}^1 \left(1 - \frac{y}{2} - y^2 + \frac{y^5}{2} \right) \, dy = \frac{4}{3} \end{aligned}$$

Problem. Compute $\int_R \int F(P) \, dA$ where R is the annular ring $1 \leq \sqrt{x^2 + y^2} \leq 2$.

There are several solutions, one of which is illustrated in Figure 13.16. Partition R into four regions, $R_1 - R_4$ each of which is in the form $a \leq x \leq b$, $f(x) \leq y \leq g(x)$. Then

$$\begin{aligned} \int_R \int F(P) \, dA &= \int_{R_1} \int F(P) \, dA + \int_{R_2} \int F(P) \, dA + \int_{R_3} \int F(P) \, dA + \int_{R_4} \int F(P) \, dA \\ &= \int_{-2}^{-1} \int_{-\sqrt{4-x^2}}^{\sqrt{4-x^2}} F(x, y) \, dy \, dx + \int_{-1}^1 \int_{\sqrt{1-x^2}}^{\sqrt{4-x^2}} F(x, y) \, dy \, dx + \\ &\quad \int_{-1}^1 \int_{-\sqrt{4-x^2}}^{-\sqrt{1-x^2}} F(x, y) \, dy \, dx + \int_1^2 \int_{-\sqrt{4-x^2}}^{\sqrt{4-x^2}} F(x, y) \, dy \, dx \end{aligned}$$

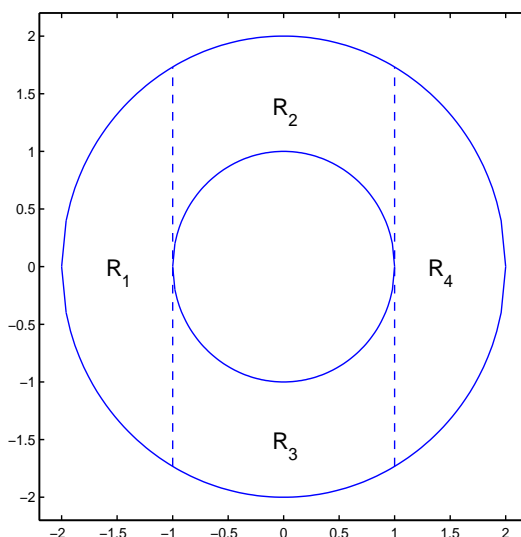

Figure 13.16: An annular ring partitioned into four regions.

Example 13.3.2 *A clever manipulation.* The normal probability density was first defined by A. De Moivre in 1733 as

$$f(t) = \frac{1}{\sigma\sqrt{2\pi}} e^{-(t-\mu)^2/2\sigma^2}.$$

The mean and standard deviation of the distribution are μ and σ . If $\mu = 0$ and $\sigma = 1$, $f(t)$ becomes

$$f(t) = \frac{1}{\sqrt{2\pi}} e^{-t^2/2}.$$

The coefficient $1/\sqrt{2\pi}$ insures that

$$\int_{-\infty}^{\infty} f(t) dt = \int_{-\infty}^{\infty} \frac{1}{\sqrt{2\pi}} e^{-t^2/2} dt = \lim_{c \rightarrow \infty} \int_{-c}^c \frac{1}{\sqrt{2\pi}} e^{-t^2/2} dt = 1$$

This requires, and we wish to prove, that

$$I = \int_{-\infty}^{\infty} e^{-t^2/2} dt = \sqrt{2\pi}$$

The difficulty stems from the lack of an antiderivative formula for $\int e^{-t^2/2} dt$. There is none. However, we write

$$\begin{aligned} I^2 &= \int_{-\infty}^{\infty} e^{-x^2/2} dx \times \int_{-\infty}^{\infty} e^{-y^2/2} dy = \int_{-\infty}^{\infty} \left(\int_{-\infty}^{\infty} e^{-x^2/2} dx \right) e^{-y^2/2} dy \\ &= \int_{-\infty}^{\infty} \int_{-\infty}^{\infty} e^{-x^2/2} e^{-y^2/2} dx dy = \int_R \int e^{-(x^2+y^2)/2} dA \end{aligned}$$

where R is the x, y -plane.

Now we use a clever approach to the last integral. Label points in the plane with polar coordinates (r, θ) where

$$r = \sqrt{x^2 + y^2} \quad \text{and} \quad \cos \theta = x/r, \quad \sin \theta = y/r$$

With these coordinates

$$f(x, y) = g(r, \theta) = e^{-r^2/2}$$

and we will compute $\int_R \int e^{-r^2/2} dA$.

For each positive number c , let R_c be the circular region centered at the origin and radius c . See Figure 13.17. For m and n positive integers, partition $[0, c]$ by $r_i = i \times c/m, i = 0, m$, and $[0, 2\pi]$ by $\theta_j = j \times 2\pi/n, j = 0, n$. R_c is partitioned into $m \times n$ subregions

$$R_{i,j} = r_{i-1} \leq r \leq r_i \quad \theta_{j-1} \leq \theta \leq \theta_j$$

The area of $R_{i,j}$ is $A_{i,j} = \left(\pi (r_i)^2 - \pi (r_{i-1})^2 \right) \times \frac{1}{n} = 2\pi \frac{r_{i-1} + r_i}{2} (r_i - r_{i-1}) \times \frac{1}{n}$

Now evaluate $e^{-r^2/2}$ in $R_{i,j}$ at $P_i = ((r_{i-1} + r_i)/2, \theta_j + \pi/n)$ and write

$$\begin{aligned} \int_{R_c} \int e^{-r^2/2} dA &\doteq \sum_{i=1}^m \sum_{j=1}^n e^{-((r_{i-1}+r_i)/2)^2/2} A_{i,j} \\ &= \sum_{i=1}^m \sum_{j=1}^n e^{-((r_{i-1}+r_i)/2)^2/2} 2\pi \frac{r_{i-1} + r_i}{2} (r_i - r_{i-1}) \frac{1}{n} \\ &= 2\pi \sum_{i=1}^m e^{-((r_{i-1}+r_i)/2)^2/2} \frac{r_{i-1} + r_i}{2} (r_i - r_{i-1}) \sum_{j=1}^n \frac{1}{n} \\ &= 2\pi \sum_{i=1}^m e^{-((r_{i-1}+r_i)/2)^2/2} \frac{r_{i-1} + r_i}{2} (r_i - r_{i-1}) \times 1 \\ &\doteq 2\pi \int_0^c e^{-r^2/2} r dr = 2\pi \left[-e^{-r^2/2} \right]_0^c = 2\pi(1 - e^{-c^2/2}) \end{aligned}$$

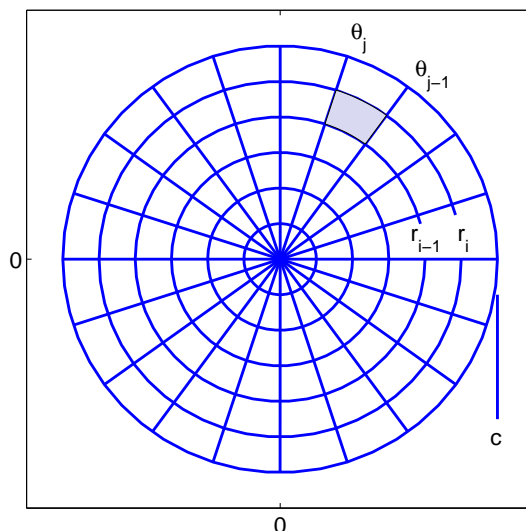

Figure 13.17: A circular region of radius c partitioned into subregions. The shaded subregion is $r_{i-1} \leq r \leq r_i, \theta_{j-1} \leq \theta \leq \theta_j$.

We conclude that

$$\int_R \int e^{-r^2/2} dA = \lim_{c \rightarrow \infty} \int_{R_c} \int e^{-r^2/2} dA = \lim_{c \rightarrow \infty} 2\pi(1 - e^{-c^2/2}) = 2\pi.$$

Therefore

$$I^2 = 2\pi \quad \text{and} \quad I = \int_{-\infty}^{\infty} e^{-t^2/2} dt = \sqrt{2\pi}$$

as was to be proved. ■

Exercises for Section 13.3, Integrals of functions of two variables.

Exercise 13.3.1 Approximate the volume of the region between the graph of F and the x, y -plane using six or more subregions of its domain and a point selected in each subregion.

- a. $F(x, y) = x \times y \quad 0 \leq x \leq 3 \quad 0 \leq y \leq 2$
- b. $F(x, y) = x + y \quad 1 \leq x \leq 3 \quad 2 \leq y \leq 5$
- c. $F(x, y) = x \times \ln y \quad 0 \leq x \leq 3 \quad 1 \leq y \leq 3$
- d. $F(x, y) = e^{-x-y} \quad 0 \leq x \leq 1 \quad 0 \leq y \leq 1$

Exercise 13.3.2 Sketch the domains over which the integrals are defined.

- a $\int_1^5 \int_x^{x^2} F(x, y) dy dx$ b $\int_1^5 \int_y^{y^2} F(x, y) dx dy$ c $\int_1^5 \int_3^4 F(x, y) dy dx$
- d $\int_0^\pi \int_{-\sin x}^{\sin x} F(x, y) dy dx$ e $\int_\pi^{2\pi} \int_{\sin y}^{-\sin y} F(x, y) dx dy$ f $\int_0^1 \int_0^{1-x^2} F(x, y) dy dx$

Exercise 13.3.3 Cyclic AMP is released by a slime mold amoeba at the center of a 6 mm by 4 mm flat plate. The concentration at position (x, y) is $e^{-x^2+y^2}$ molecules/mm², where the x -axis runs through the center of the plate in the 6 mm direction, the y -axis runs through the center of the plate and is perpendicular to the x -axis.

- Write an integral that is the amount of cyclic AMP released by the amoeba.
- Compute an approximate value of the integral.

Exercise 13.3.4 Write but do not compute the iterated form of the integral $\int_R \int F(P) dA$ for the functions F and domains indicated. In i. and j. write the integral as the sum of two iterated integrals.

- $F(x, y) = x \times y$ $0 \leq x \leq 3$ $0 \leq y \leq 2$
- $F(x, y) = x + y$ $1 \leq x \leq 3$ $2 \leq y \leq 5$
- $F(x, y) = x \times \ln y$ $0 \leq x \leq 3$ $1 \leq y \leq 3$
- $F(x, y) = x^2 y$ $0 \leq x \leq \pi$ $0 \leq y \leq \sin x$
- $F(x, y) = x + y$ $1 \leq x \leq 2$ $x \leq y \leq x^2$
- $F(x, y) = x \times y^2$ $1 \leq y \leq 2$ $y \leq x \leq y^2$
- $F(x, y) = x \times y$ $0 \leq x + y \leq 2$ $0 \leq x, 0 \leq y$
- $F(x, y) = x + y$ $0 \leq x^2 + y^2 \leq 1$
- $F(x, y) = x \times \ln y$ $1 \leq x + y \leq 3$ $0 \leq x, 0 \leq y$
- $F(x, y) = x \times \ln y$ $1 \leq x^2 + y^2 \leq 4$ $0 \leq x, 0 \leq y$

Exercise 13.3.5 Evaluate the integrals.

- $\int_0^1 \int_2^4 x y^2 dy dx$
- $\int_2^4 \int_0^1 x y^2 dx dy$
- $\int_0^1 \int_2^4 x y^2 dx dy$
- $\int_0^1 \int_0^y x y^2 dx dy$
- $\int_0^1 \int_{x^2}^x x y dy dx$
- $\int_1^4 \int_y^{y^2} x^2 + y^2 dx dy$
- $\int_1^2 \int_{e^{-x}}^{e^x} \frac{x}{y} dy dx$
- $\int_0^{\sqrt{3}} \int_1^{4-x^2} x + y dy dx$
- $\int_0^1 \int_{1-x^2}^{4-x^2} x + y dy dx$

Exercise 13.3.6 Write an integral that is the volume of the region below the graph of

$$z = 16 - x^2 - 4y^2$$

and above the x, y -plane.

13.4 The diffusion equation $u_t(x, t) = c^2 u_{xx}(x, t)$.

Partial derivatives may appear in equations and when they do the equations are called partial differential equations. This is a vast field of study. We give one very important example, the diffusion equation, and suggest a numerical method for its solution.

The diffusion equation in one space dimension is

$$u_t(x, t) = c^2 u_{xx}(x, t), \quad a \leq x \leq b, \quad 0 \leq t. \quad (13.20)$$

Embryonic digit development On the limb bud of the developing vertebrate embryo, there is a "zone of polarizing activity" (ZMP) on the "pinky" side of the limb bud that causes the pinky side to be different from the thumb side. A protein, *sonic hedgehog*, is emitted from the ZMP and diffuses across the limb bud. The concentration of sonic hedgehog decreases with the distance from the ZMP; those digits closest to ZMP with high hedgehog protein concentration develop into the pinky and ring fingers; those farthest from the ZMP with low hedgehog protein concentration develop into the index finger and thumb (see Figure 13.18). This extremely important diffusion example is too complex for us to model, and we turn to simpler problems.

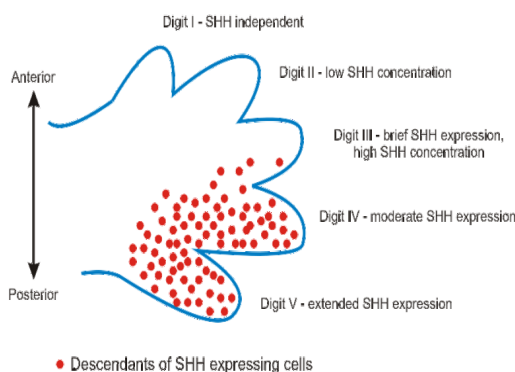
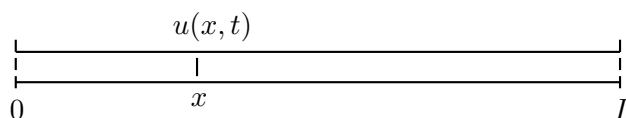

Figure 13.18: Sonic hedgehog specifies digit identity in mammalian development. From http://en.wikipedia.org/wiki/Hedgehog_signaling_pathway



You may think of a brass rod of diameter, d , that is small compared to its length, $L = b - a$, and $u(x, t)$ as the temperature in the rod at position x and at time t . If the temperature is not at equilibrium, the flow of heat in the rod will cause the temperature to equilibrate according to Equation 13.20. For a fixed value, \bar{x} of x , $u(\bar{x}, t)$ describes the temperature at position \bar{x} for times $t \geq 0$. For a fixed value, \bar{t} of t , $u(x, \bar{t})$ describes the temperature distribution in the rod at time \bar{t} .

Alternatively, you may think of a glass tube of diameter, d , that is small compared to its length, $L = b - a$, and is filled with distilled water with a small amount of salt dissolved in it, and $u(x, t)$ as the concentration of salt at position, x , and time t . If the salt concentration is not at equilibrium, salt will flow in the rod and will cause the concentration to equilibrate according to Equation 13.20.

A single equation describes $u(x, t)$ for both of these problems and a host of other problems. Molecules diffuse in intercellular fluids during embryonic development and within intracellular fluids; diseases diffuse in a population; an invasive species diffuses over an extended range. James D. Murray has shown² that a linked pair of reaction-diffusion equations defined on a

²James D. Murray, How the leopard gets its spots, *Scientific American*, 1988, **258**(3) pp 80-87., James D. Murray, *Mathematical Biology*, Springer-Verlag, Heidelberg, 1989.

two-dimensional surface can nicely replicate numerous mammalian coat patterns, ranging from the giraffe, leopard, zebra, to the elephant (neutral).

In order to determine $u(x, t)$ it is necessary to know the initial state of u ,

$$u(x, 0) = g(x), \quad \text{say,}$$

and the constraints on $u(x, t)$ at the ends of the rod,

$$u(a, t) = h_a(t), \quad \text{and} \quad u(b, t) = h_b(t), \quad \text{for example.}$$

We derive the diffusion equation in terms of the diffusion of salt (or any solute). Consider a circular glass rod of cross sectional area A and length L filled with water and assume that at time $t = 0$ the concentration of the salt along the tube is $g(x)$. Let $u(x, t)$ be the salt concentration at distance x from one end of the rod at time t . Figure 13.19A. Assume that the diameter of the rod is small enough that the salt concentration at any position x along the rod depends only on x .

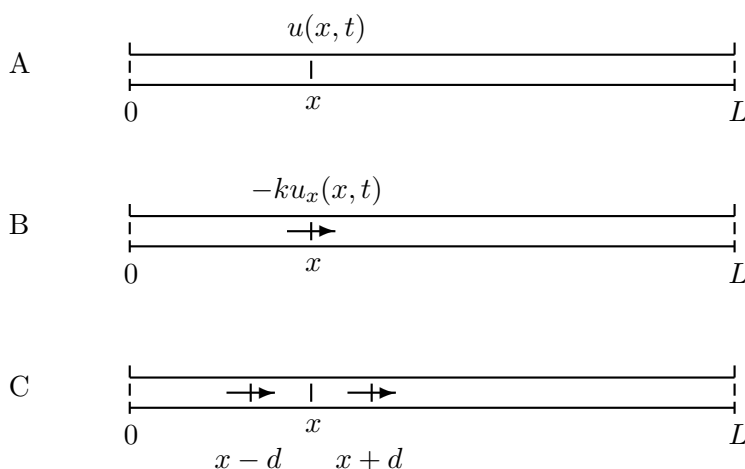

Figure 13.19: A. Glass rod, salt concentration at x at time t is $u(x, t)$. B. The rate at which salt flows past position x is proportional to $-u_x(x, t)$. C. The amount of salt between $x - d$ and $x + d$ at time t is approximately $u(x, t) \times A \times 2d$.

Diffusion: Mathematical model 1. Salt tends to flow from regions of high concentration to regions of low concentration. The rate at which salt flows past position x in the direction of increasing x at time t is proportional to $-u_x(x, t)$ and to A , the cross sectional area of the rod. Figure 13.19B.

From this model we write

$$R(x, t) = -k A u_x(x, t) \tag{13.21}$$

where $R(x, t)$ is the rate at which salt diffuses past position x at time t and k is a proportionality constant that is a property of the solvent/solute system.

Units. The units on u , u_x , A and R are, respectively,

$$\begin{aligned} u &: \frac{\text{gm}}{\text{cm}^3} && \frac{\text{mass}}{\text{distance}^3} \\ u_x &: \frac{\text{gm}}{\text{cm}^3 \times \text{cm}} && \frac{\text{mass}}{\text{distance}^4} \\ A &: \text{cm}^2 && \text{distance}^2 \\ R &: \frac{\text{gm}}{\text{sec}} && \frac{\text{mass}}{\text{time}} \end{aligned}$$

In order to balance the units on Equation 13.21, the units on k must be cm^2/sec .

$$R = k A u_x, \quad \frac{\text{gm}}{\text{sec}} = k \times \text{cm}^2 \times \frac{\text{gm}}{\text{cm}^3 \times \text{cm}}, \quad \frac{1}{\text{sec}} = k \times \frac{1}{\text{cm}^2}, \quad k = \frac{\text{cm}^2}{\text{sec}}.$$

Now consider a section of the rod between $x - d$ and $x + d$, Figure 13.19C. During a time interval t to $t + \delta$ salt flows past $x - d$, flows past $x + d$, and accumulates (or depletes) in the section.

Diffusion: Mathematical model 2. The amount of salt in any small region of the tube is approximately the concentration of salt at some point in the region times the volume of the region.

From Mathematical Model 2 we write that the amount of salt in the section from $x - d$ to $x + d$ at time t is approximately $u(x, t) \times A \times 2d$.

Diffusion: Mathematical model 3. During a time interval from t to $t + \delta$, the amount of salt that flows into a region minus the amount of salt that flows out of the region is the the accumulation within the region.

Now $R(x - d, t)$ is the rate at which salt flows past $x - d$ in the direction of increasing x . The amount of salt that flows into the section $x - d$ to $x + d$ during the time t to $t + \delta$ is approximately $R(x - d, t) \times \delta$. The amount of salt that flows out of the section during time t to $t + \delta$ is approximately $R(x + d, t) \times \delta$. Either of rates, $R(x - d, t)$ and $R(x + d, t)$, rates may be negative with corresponding flow negative.

The accumulation in the section during a time interval from t to $t + \delta$ is approximately $u(x, t + \delta) A 2d$ minus $u(x, t) A 2d$.

For Mathematical Model 3, we write

$$\begin{aligned} u(x, t + \delta) A 2d - u(x, t) A 2d &\doteq R(x - d, t) \delta - R(x + d, t) \delta \\ &= -k A u_x(x - d, t) \delta - (-k A u_x(x + d, t)) \delta \\ \frac{u(x, t + \delta) - u(x, t)}{\delta} &\doteq k \frac{u_x(x + d, t) - u_x(x - d, t)}{2d} \end{aligned} \tag{13.22}$$

Using the Mean Value Theorem³ twice, there are numbers τ in $(t, t + \delta)$ and ξ in $(x - d, x + d)$ such that

$$\frac{u(x, t + \delta) - u(x, t)}{\delta} = u_t(x, \tau) \quad \text{and} \quad \frac{u_x(x + d, t) - u_x(x - d, t)}{2d} = u_{xx}(\xi, t)$$

Then

$$u_t(x, t) \doteq u_t(x, \tau) \doteq k u_{xx}(\xi, t) \doteq k u_{xx}(x, t)$$

As $\delta \rightarrow 0$ and $d \rightarrow 0$, all of the errors reduce (we suppose to zero) and we write

$$u_t(x, t) = k u_{xx}(x, t) \quad \text{Diffusion equation.} \tag{13.23}$$

The proportionality constant k is positive and is usually written as c^2 to signal this and to simplify analytical solutions. As noted above, the units on k are cm^2/sec . The size of k reflects how

³Theorem 9.1.1, Mean Value Theorem: If F is a continuous function defined on an interval $[a, b]$ and F' is continuous on (a, b) , then there is a number c in (a, b) such that $F'(c) = (F(b) - F(a))/(b - a)$.

rapidly the salt moves in water or the heat moves in a rod or a disease spreads in a population or generally how rapidly a substance diffuses in its medium. If k is large, $u(x, t)$ changes rapidly; if k is small, $u(x, t)$ changes slowly. For example,

$$u(x, t) = e^{-kt} \sin x, \quad 0 \leq x \leq \pi, \quad 0 \leq t$$

is a solution to Equation 13.23:

$$\begin{aligned} u_t(x, t) &= -ke^{-kt} \sin x, & u_x(x, t) &= e^{-kt} \cos x, & u_{xx}(x, t) &= -e^{-kt} \sin x, \\ u_t(x, t) &= ku_{xx}(x, t). \end{aligned}$$

Graphs of $e^{-t} \sin x$ and $e^{-0.5t} \sin x$ appear in Figure 13.20A and B respectively. It can be seen that the graph in B with smaller k changes more slowly than the graph in A.

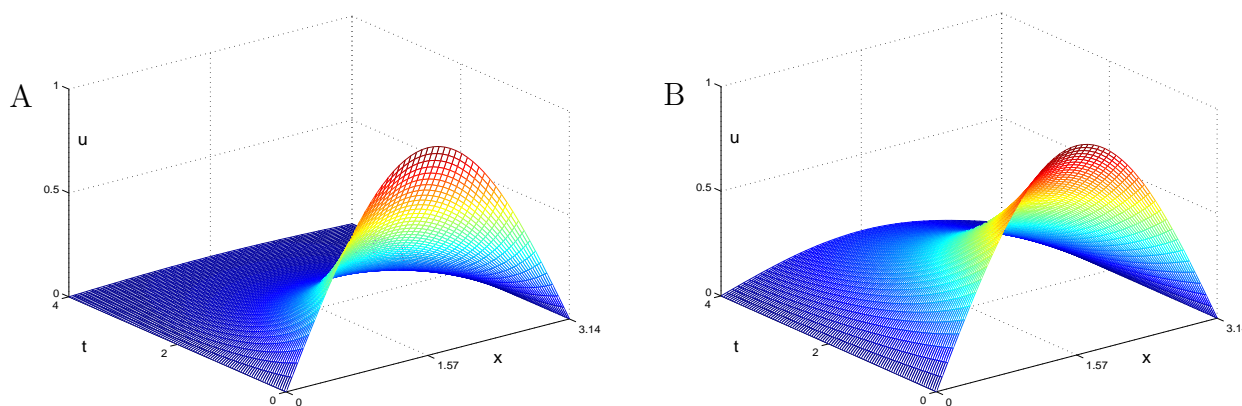

Figure 13.20: A. Graph in 3-dimensional space of $u(x, t) = e^{-t} \sin x$. B. Graph of $u(x, t) = e^{-0.5t} \sin x$.

Explore 13.4.1 For any salt concentration, $u(x, t)$, the amount of salt in the tube at time t is $\int_0^L u(x, t) dx$. Show that for $u(x, t) = e^{-kt} \sin x$, $0 \leq x \leq \pi$, the amount, of salt in the tube at time t is $2e^{-kt}$. In both cases, $\int_0^\pi u(x, t) dx$ is initially 2 and decreases with time; the amount of salt in the tube is decreasing and salt must be leaking out the ends.

The initial concentration of salt in the rod is required in order to compute the concentration at later times. Assume that there is a known function g such that at time $t = 0$ the concentration at position x is $g(x)$. Then

$$u(x, 0) = g(x) \quad 0 < x < L \quad \text{Initial condition.} \tag{13.24}$$

Finally we need some knowledge about the ends of the rod, referred to as *boundary conditions*. The ends may be sealed so that no salt diffuses past either end. This is expressed as

$$u_x(0, t) = u_x(L, t) = 0, \quad 0 \leq t, \quad \text{Insulated boundary conditions.} \tag{13.25}$$

Alternatively, we might assume the rod connects two reservoirs in which the salt concentration is constant, salt may diffuse into or out of the reservoir, but there is no flow of solvent into or out of the rod. Then there will be two concentrations, C_0 and C_L , such that

$$u(0, t) = C_0, \quad u(L, t) = C_L, \quad 0 \leq t \quad \text{Fixed boundary conditions.} \tag{13.26}$$

Explore 13.4.2 Suppose the $x = 0$ end of the tube is attached to a reservoir with salt concentration $c_0 = 1$ and the $x = L$ end of the tube is sealed. What would be the boundary conditions? What would $u(x, t)$ be for 'large' values of t ?

Equation 13.23 for which $u(x, t)$ is concentration of salt also describes the temperature, $u(x, t)$, in a rod of length L that is insulated along its sides. In this case, the initial condition $g(x)$ would be the temperature distribution along the rod at time $t = 0$. The rod may also be insulated at each end and boundary condition 13.25 would apply, and this accounts for the name 'Insulated boundary condition.' Alternatively, one end of the rod may be exposed to, say, steam and the other end exposed to ice water, and Fixed Boundary Condition 13.26 would apply.

Explore 13.4.3 Suppose on a flat sandy beach the temperature at a depth of 2 meters is constant, equal to 20°C , and the temperature at the surface of the beach is $27 + 4 \sin((2\pi/24)t)$ $^\circ\text{C}$. Suppose the sand temperature varies only vertically. What equations would you like to solve if you were interested in a nest of turtle eggs buried 80 cm?

There are analytical solutions to the diffusion equation 13.23 with initial condition 13.24 with either of the boundary conditions 13.25 or 13.26. Only a few of them are simple enough for our use. We describe one example and include two examples in Exercises 13.4.5 and 13.4.10.

Example 13.4.1 *Problem.* Let

$$u(x, t) = 30 * (1 - e^{-t} \cos \pi * x) \quad 0 \leq x \leq 2 \quad 0 \leq t. \quad (13.27)$$

Show that

$$u_t(x, t) = \frac{1}{\pi^2} u_{xx}(x, t), \quad u(x, 0) = 30 * (1 - \cos \pi x), \quad \text{and} \quad \begin{array}{l} u_x(0, t) = 0 \\ u_x(2, t) = 0. \end{array} \quad (13.28)$$

Assuming Equations 13.28 are correct, $u(x, t)$ would describe the temperature in a rod of length 2 that is perfectly insulated along its side, had an initial temperature of $30 * (1 - \cos \pi x)$ at position x , and was perfectly insulated on each end. The diffusion coefficient of the material in the rod is $k = 1/\pi^2$. Alternatively, the equations would describe the salt concentration in a tube closed at each end when the initial salt concentration at position x was $30 * (1 - \cos \pi x)$.

Explore 13.4.4 What will be the 'eventual' temperature distribution (or salt concentration) in the rod (tube)?

A graph of the initial temperature distribution appears in Figure 13.21A, and graphs of the temperature at times 0, 0.5, 1, 1.5 and 2 appear in Figure 13.21B.

Solution. First compute some partial derivatives.

$$u(x, t) = 30(1 - e^{-t} \cos \pi x) \quad (13.29)$$

$$u_t(x, t) = 30(0 - (e^{-t})(-1) \cos \pi x) = 30e^{-t} \cos(\pi x) \quad (13.30)$$

$$u_x(x, t) = 30(0 - e^{-t}(-\sin \pi x)(\pi)) = 30\pi e^{-t} \sin \pi x \quad (13.31)$$

$$u_{xx}(x, t) = 30\pi^2 e^{-t} \cos \pi x \quad (13.32)$$

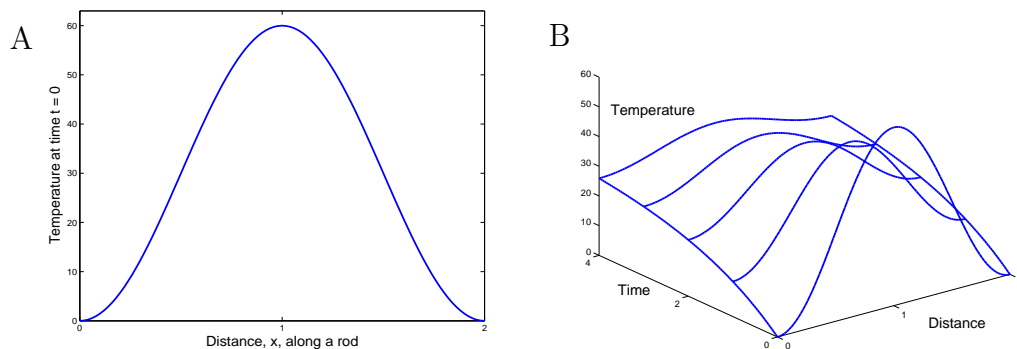

Figure 13.21: Partial graphs of Equation 13.27. A. Graph of temperature at time $t = 0$. B. Graphs of the temperature at times 0, 0.5, 1.0, 1.5 and 2.0. The graphs of temperature at the ends $x = 0$ and $x = 2$ are included.

From Equations 13.30 and 13.32

$$u_t(x, t) = 30e^{-t} \cos(\pi x) = \frac{1}{\pi^2} 30\pi^2 e^{-t} \cos(\pi x) = \frac{1}{\pi^2} u_{xx}.$$

From Equation 13.27

$$u(x, 0) = 30 * (1 - e^{-t} \cos \pi * x) \Big|_{t=0} = 30(1 - \cos \pi x).$$

From Equation 13.31,

$$u_x(0, t) = 30\pi e^{-t} \sin \pi x \Big|_{x=0} = 0 \quad \text{and} \quad u_x(2, t) = 30\pi e^{-t} \sin \pi x \Big|_{x=2} = 0$$

Thus all of Equations 13.28 are satisfied.

13.4.1 Numerical solutions to the diffusion equation.

Finding analytic solutions to the diffusion equation is beyond the scope of this text. However, a numerical scheme for approximating a solution is well within reach.

Partition the tube into n intervals of length $d = L/n$, and partition time into intervals of length δ , as shown in Figure 13.22 for $n = 5$ and the space time grid shown above the tube.

Begin with Equation 13.23,

$$u_t(x, t) = k u_{xx}(x, t)$$

From Equations 9.22 and 9.24

$$u_t(x, t) \doteq \frac{u(x, t + \delta) - u(x, t)}{\delta} \quad \text{and} \quad u_{xx}(x, t) \doteq \frac{u(x + d, t) - 2u(x, t) + u(x - d, t)}{d^2}.$$

Using these in the previous equation leads to

$$\frac{u(x, t + \delta) - u(x, t)}{\delta} \doteq k \frac{u(x + d, t) - 2u(x, t) + u(x - d, t)}{d^2}. \tag{13.33}$$

Now we write an exact equation

$$\frac{v_{i,j+1} - v_{i,j}}{\delta} = k \frac{v_{i+1,j} - 2v_{i,j} + v_{i-1,j}}{d^2}. \tag{13.34}$$

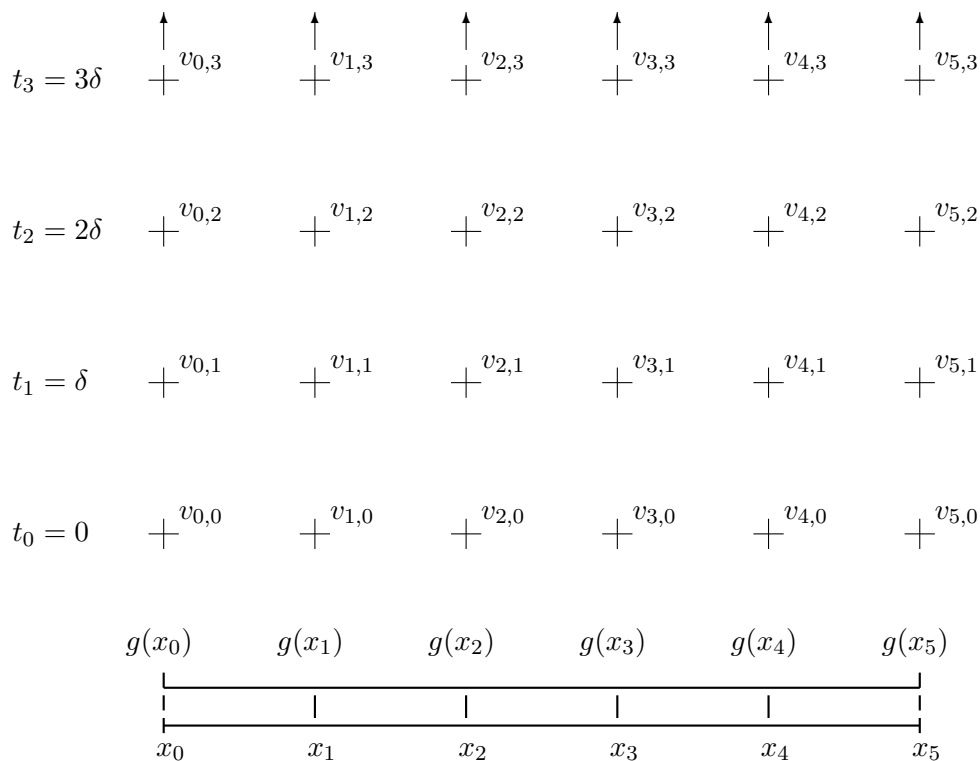

Figure 13.22: Glass tube and grid for diffusion computation.

where $v_{i,j}$ is an approximation to $u(i * d, j * \delta)$. Equations 13.34 can be solved as is illustrated in the next example. Using this notation in Equation 13.34 and rearranging leads to

$$v_{i,j+1} = v_{i,j} + \hat{k} (v_{i-1,j} - 2v_{i,j} + v_{i+1,j}) \quad \text{where} \quad \hat{k} = \frac{k \delta}{d^2}. \tag{13.35}$$

Equation 13.35 defines $v_{i,j+1}$ (at time value $j + 1$) in terms of $v_{i-1,j}$, $v_{i,j}$ and $v_{i+1,j}$, values of v at the immediately preceding time value j . See Figure 13.23. The computation is started at time $j = 0$ with values of $v_{i,0}$ equal to values of the initial condition $g(x)$ and progresses 'upward' in time, one layer at a time.

Example 13.4.2 Assume there is a glass tube of length $L = 1$ meter and of cross sectional area $A = 1$ cm filled with water; initially there is no salt in the tube; the left end is attached to a salt water reservoir with salt concentration = 1 and the right end is attached to a pure water reservoir. Let $u(x, t)$ be the salt concentration in the tube at position x and time t .

Explore 13.4.5 What do you expect the 'eventual' salt concentration along the tube to be?

The diffusion equation is $u_t(x, t) = k u_{xx}(x, t)$. Because initially there is no salt in the tube, $g(x) = 0$ for $0 < x < 1$, and the reservoirs at the ends of the tube imply the fixed boundary conditions 13.26, $u(0, t) = 1$ and $u(1, t) = 0, 0 \leq t$.

Partition the tube into 5 equal intervals. There is in Figure 13.22 an array of points horizontally distributed with position x along the tube and distributed vertically in time t .

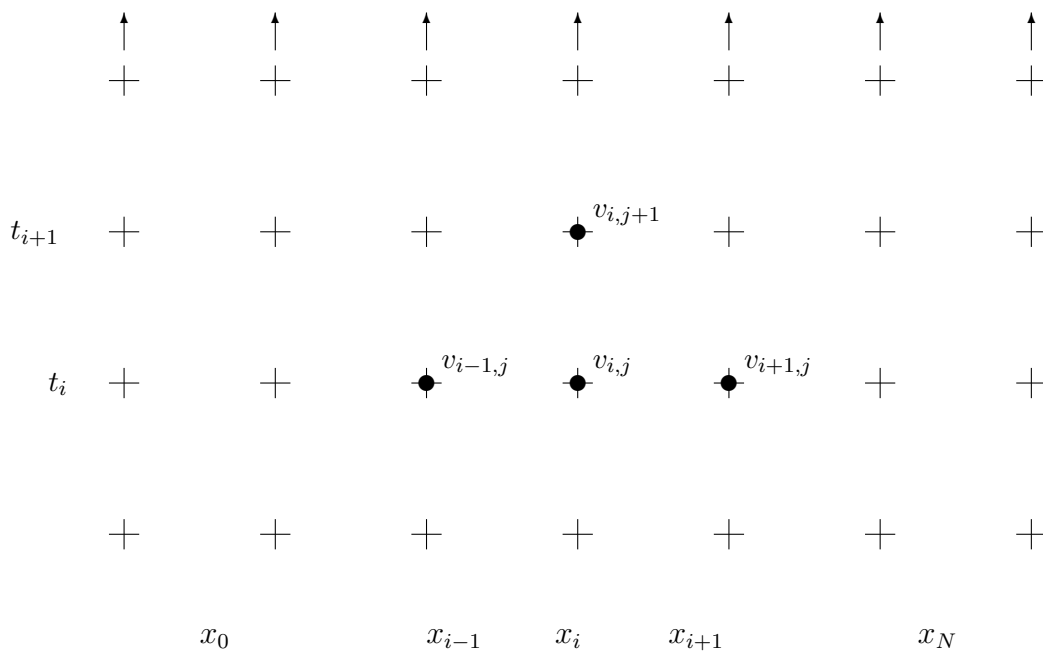

Figure 13.23: Geometric arrangement of the grid points of Equation 13.35.

In this example,

$$v_{i,j} \doteq u(i \times 1/5, j \times \delta), \quad i = 1, 5, \quad j = 1, \dots.$$

and from Equation 13.34

$$v_{i,j+1} = v_{i,j} + \hat{k}(v_{i-1,j} - 2v_{i,j} + v_{i+1,j}) \quad \text{where} \quad \hat{k} = \frac{k \delta}{d^2}. \quad (13.36)$$

The boundary conditions 13.26 with $u(0, t) = 1$ and $u(1, t) = 0$ lead to

$$v_{0,j} = 1 \quad v_{5,j} = 0 \quad (13.37)$$

The initial condition and equations 13.36 determine the $v_{i,j}$ one horizontal layer at a time for the interior grid points, $1 < i < 5$.

Begin with the initial condition, Equation 13.24:

$$v_{i,0} = g(x_i) = 0, \quad i = 1, 4 \quad (13.38)$$

Then for the bottom layer of the grid in Figure 13.22

$$v_{0,0} = 1 \quad \text{and} \quad v_{j,0} = 0 \quad j = 1, \dots, 5.$$

Then compute the next layer up for $t = \delta$:

$$\begin{aligned} v_{1,1} &= v_{1,0} + \hat{k}(v_{0,0} - 2v_{1,0} + v_{2,0}) \\ v_{2,1} &= v_{2,0} + \hat{k}(v_{1,0} - 2v_{2,0} + v_{3,0}) \\ v_{3,1} &= v_{3,0} + \hat{k}(v_{2,0} - 2v_{3,0} + v_{4,0}) \\ v_{4,1} &= v_{4,0} + \hat{k}(v_{3,0} - 2v_{4,0} + v_{5,0}) \\ v_{0,1} &= v_{1,1} \\ v_{5,1} &= v_{4,1} \end{aligned}$$

Table 13.1: A MATLAB program that computes approximations from Equations 13.36-13.38 with $\hat{k} = 0.2$

```
close all;clc;clear
for j = 1:6
    v(1,j)=0;
end
v(1,1)=1;
for i = 2:16
    v(i,1)=1;
    v(i,6)=0;
    for j = 2:5
        dd=v(i-1,j-1)-2*v(i-1,j)+v(i-1,j+1);
        v(i,j) = v(i-1,j)+0.2*dd;
    end
end
end
u=flipud(v)
```

In a similar way as many layers as necessary can be computed. The computations for $\hat{k} = 0.2$ are shown below. The next MATLAB program produces the computations that appear in Table 13.1.

Remember that $\hat{k} = \frac{k\delta}{d^2}$ incorporates the time step, δ , and dimension step, d , as well as the diffusion constant, k .

t_{15}	1.000	0.688	0.421	0.224	0.092	0.000
t_{14}	1.000	0.678	0.406	0.209	0.084	0.000
t_{13}	1.000	0.667	0.389	0.194	0.075	0.000
t_{12}	1.000	0.655	0.371	0.178	0.066	0.000
t_{11}	1.000	0.642	0.351	0.160	0.056	0.000
t_{10}	1.000	0.626	0.329	0.142	0.047	0.000
t_9	1.000	0.609	0.305	0.123	0.037	0.000
t_8	1.000	0.588	0.278	0.102	0.028	0.000
t_7	1.000	0.565	0.248	0.082	0.019	0.000
t_6	1.000	0.536	0.214	0.061	0.011	0.000
t_5	1.000	0.501	0.177	0.041	0.005	0.000
t_4	1.000	0.458	0.134	0.022	0.002	0.000
t_3	1.000	0.400	0.088	0.008	0.000	0.000
t_2	1.000	0.320	0.040	0.000	0.000	0.000
t_1	1.000	0.200	0.000	0.000	0.000	0.000
t_0	1.000	0.000	0.000	0.000	0.000	0.000
	x_0	x_1	x_2	x_3	x_4	x_5

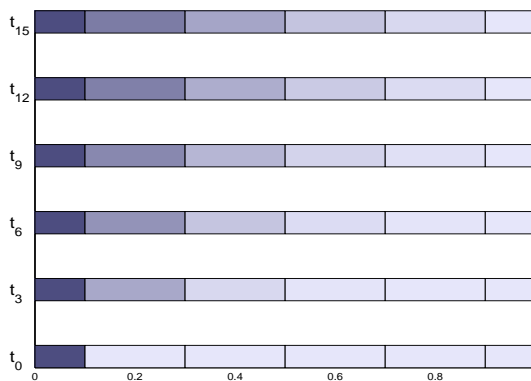

These computations may be visualized as salt (gray color) migrating to the right in a tube as illustrated in the graphic. ■

The data are printed as we have been discussing, with t increasing upward. This is accomplished by the peculiar last command `u = flipud(v)`. You may prefer replacing this with the command `u = v` for some applications.

The notation $v(i, j)$ is consistent with our previous discussion, but some technologies, particularly programmable hand calculators, may not have the two dimensional arrays or may be limited with the size of such arrays. The following equivalent program demands less storage and produces the same data, but not with the same vertical orientation.

```
close all;clc;clear
for j = 1:6
    oldv(j)=0;
end
oldv(1)=1;
oldv
for i = 2:16
    oldv(1)=1;
    oldv(6)=0;
    for j = 2:5
        dd=oldv(j-1)-2*oldv(j)+oldv(j+1);
        newv(j) = oldv(j)+0.2*dd;
    end
    newv
    oldv=newv;
end
```

There is a severe constraint on $\hat{k} = \frac{k \delta}{d^2}$ in order that Equations 13.35 yield values of $v_{i,j}$ that reasonably approximate the target function $u(x, t)$. We must have

$$\hat{k} = \frac{k \delta}{d^2} < \frac{1}{2}. \quad (13.39)$$

The consequence of $\hat{k} > 1/2$ is illustrated in Exercise 13.4.1b, where $\hat{k} = 0.6$. In Example 13.4.2 the tube partition is $d = 0.2$ meters. If one wanted a smaller partition in order to more accurately approximate the salt concentration, say $d = 0.01$, one centimeter or 1/20th of the space step of the example, then the time step δ would have to be 1/400th of the first time dimension. It would take 400 iterations of the resulting equations in order to move one of the original time steps. There is an interesting alternate procedure that is not so constrained that will be found in numerical analysis books.

Exercises for Section 13.4, The diffusion equation.

- Exercise 13.4.1**
1. Use MATLAB or similar technology to run a program similar to or the same as that of Table 13.1, run it, and confirm the computations shown in Table 13.1.
 2. The program is written for $\hat{k} = 0.2$. Alter the program so that $\hat{k} = 0.6$ and run it. Do the computed approximations match what you think will be the salt concentrations?
 3. The program is written for $\hat{k} = 0.2$. Alter the program so that $\hat{k} = 0.1$ and run it. Is the last temperature distribution in the rod at equilibrium?
 4. Retain $\hat{k} = 0.1$ and change `i = 2:17` to `i = 2:100`. Now is the last temperature distribution close to equilibrium?

Exercise 13.4.2 a. Use MATLAB or similar technology to run a program similar to or the same as that of Table 13.1; alter it to accommodate 10 intervals in $[0,1]$ for x . Retain $\hat{k} = 0.2$. Run the program and observe the result.

b. The x -interval $d = 0.1$, is now one-half of the previous value of 0.2, and

$$\hat{k} = \frac{k \delta}{d^2}.$$

Assume that the conductance coefficient, k , has not changed. How must the time increment, δ , change in order that \hat{k} and k be the same as before and d be one-half of its previous value?

c. Run your program. What values in the new data most closely correspond to values in Table 13.1.

Exercise 13.4.3 Solve Equations 13.36, 13.37, and 13.38 using an Excel spread sheet.

Exercise 13.4.4 A number of diffusion simulator programs can be found with Google, "diffusion simulator". Most seemed to be blocked to public access, however, and most will require your computer to be able to run Java Applets. Try to find access to a diffusion simulator and run some experiments on it.

Exercise 13.4.5 a. Show that

$$u(x, t) = 20 e^{-t} \sin \pi x, \quad 0 \leq x \leq 1, \quad 0 \leq t \quad (13.40)$$

solves

$$u_t(x, t) = \frac{1}{\pi^2} u_{xx}(x, t), \quad u(x, 0) = 20 \sin \pi x, \quad \text{and} \quad u(0, t) = u(1, t) = 0 \quad (13.41)$$

b. Describe a physical problem for which this is a solution.

c. What is the 'eventual' value of $u(x, t)$ (what is $\lim_{t \rightarrow \infty} u(x, t)$)?

d. At what time, t , will the maximum value of $u(x, t)$ for $0 \leq x \leq 1$ be 20?

Exercise 13.4.6 In Example 13.4.2, what is

$$\lim_{t \rightarrow \infty} u(x, t)?$$

Alternatively, what is

$$\lim_{j \rightarrow \infty} v_{i,j}?$$

The columns of Table 13.1 may suggest an answer.

Exercise 13.4.7 a. How should the MATLAB program in Table 13.1 be modified if initially the salt concentration in the tube were 0.5?

b. If initially the salt concentration at position x in the tube is x ?

Exercise 13.4.8 For the insulated ends boundary condition 13.26

$$u_x(0, t) = 0 \quad \text{and} \quad u_x(L, t) = 0,$$

you might approximate these partial derivatives with the difference quotients

$$u_x(0, t) \doteq \frac{u(0 + d, t) - u(0, t)}{d} \quad \text{and} \quad u_x(L, t) \doteq \frac{u(L, t) - u(L - d, t)}{d}.$$

Then $u_x(0, t) = 0$ and $u_x(L, t) = 0$ would lead to

$$u(0, t) = u(0 + d, t) \quad \text{and} \quad u(L, t) = u(L - d, t).$$

Suppose the initial condition is

$$u(x, 0) = x$$

- Modify the MATLAB program in Table 13.1 (better, modify the MATLAB program of Exercise 13.4.2) to use this boundary condition and initial condition.
- Run the program and report the result.
- What do you expect

$$\lim_{t \rightarrow \infty} u(x, t) \quad \text{to be?}$$

- Exercise 13.4.9**
- For any $g(x)$, how much salt is in the rod (of length 1 meter and cross section 1cm^2) at time $t = 0$? Consider some special cases such as $g(x) \equiv 1\text{g/cm}^3$ and $g(x) = x \text{ g/cm}^3$. Then for general g , think, approximately how much salt is in the first 10 cm of the rod, the second 10 cm of the rod, \dots , the last 10 cm of the rod, and add those quantities.
 - For the insulated end boundary condition 13.26 and any initial condition $g(x)$ and rod length L what is

$$\lim_{t \rightarrow \infty} u(x, t) ?$$

Exercise 13.4.10 Suppose there is an infinitely long tube containing water lying along the X -axis from $-\infty$ to ∞ and at time $t = 0$ a bolus injection of one gram of salt is made at the origin. Let $u(x, t)$ be the concentration of salt at position x in the tube at time t .

Considering $t = 0$ is a bit stressful. The bolus injection of one gm at the origin causes the concentration at $x = 0$ and $t = 0$ to be rather large; $u(0, 0) = \infty$; but $u(x, 0) = 0$ for $x \neq 0$.

Moving on, we assume that for $t > 0$

$$u_t(x, t) = k u_{xx}(x, t) \tag{13.42}$$

where the diffusion coefficient, k , describes the rate at which salt diffuses in water.

- Show that

$$u(x, t) = \frac{1}{\sqrt{4\pi kt}} e^{-x^2/(4kt)} \tag{13.43}$$

is a solution to Equation 13.42.

- Suppose $k = 1/4$. Sketch the graphs of $u(x, 1)$, $u(x, 4)$, and $u(x, 8)$.

- c. Suppose $k = 1/4$. Sketch the graphs of $u(x, 1)$, $u(x, 1/2)$, and $u(x, 1/4)$.
- d. Estimate the areas under the previous curves. For any time, t_0 , what do you expect to be the area under the curve of $u(x, t_0)$, $-\infty < x < \infty$.

Exercise 13.4.11 Diffusion in two dimensions is similar to that in one dimension. The two-dimensional diffusion equation is

$$u_t(x, y, t) = k(u_{xx}(x, y, t) + u_{yy}(x, y, t)). \quad (13.44)$$

1. Suppose a square thin copper plate is embedded in perfect thermal insulation with only one edge exposed. Initially the plate is at 0°C . Then 100°C steam passes over the exposed edge. Describe how you might approximate the temperature distribution within the plate as time progresses.
2. A single instance of a highly contagious influenza occurs at the center of a square city and diffuses through the uniformly distributed population according to Equation 13.44, with $u(x, y, t)$ being the fraction of the population at location (x, y) that is infected at time t . Describe how you may approximate the progress of the disease as a function of time.

Chapter A

Summation Notation and Mathematical Induction

A.1 Summation Notation.

We use the symbol, \dots , called an *ellipsis*. Consider the sum

$$\left(\frac{1}{10}\right)^2 + \left(\frac{2}{10}\right)^2 + \dots + \left(\frac{9}{10}\right)^2 + \left(\frac{10}{10}\right)^2$$

The ellipsis, \dots , replaces some of the terms. In this particular instance, \dots replaces

$$\left(\frac{3}{10}\right)^2 + \left(\frac{4}{10}\right)^2 + \left(\frac{5}{10}\right)^2 + \left(\frac{6}{10}\right)^2 + \left(\frac{7}{10}\right)^2 + \left(\frac{8}{10}\right)^2$$

The excitement of writing these additional terms is rather limited, and most students readily accept this abbreviation¹. It is particularly useful in writing sums with 1000 or more terms. On occasions, one sees something like

$$\left[\left(\frac{1}{10}\right)^2 + \left(\frac{2}{10}\right)^2 + \dots + \left(\frac{k}{10}\right)^2 + \dots + \left(\frac{10}{10}\right)^2 \right] \times \frac{1}{10}$$

The term $\left(\frac{k}{10}\right)^2$ is a generic formula for the k th term in the sum. The generic term is useful, and it is important to be able to recognize a pattern for the terms of the sum. When $k = 1$ is substituted into the generic formula $\left(\frac{k}{10}\right)^2$ we get $\left(\frac{1}{10}\right)^2$ which is the first term of the sum. Similarly, substitution of $k = 2$ yields the second term, and substitution of $k = 10$ yields the 10th term.

¹This is easily grasped, as illustrated by the title of a children's book, "One, Two, Skip a Few, Ninety-nine, One Hundred".

Some sums and generic terms are illustrated below.

$\sqrt{7} + \sqrt{8} + \sqrt{9} + \sqrt{10} + \sqrt{11}$	\sqrt{k}	$\sum_{k=7}^{11} \sqrt{k}$
$\sqrt{7} + \sqrt{8} + \sqrt{9} + \sqrt{10} + \sqrt{11}$	$\sqrt{k+6}$	$\sum_{k=1}^5 \sqrt{k+6}$
$1^2 + 3^2 + 5^2 + 7^2 + 9^2 + 11^2$	$(2k-1)^2$	$\sum_{k=1}^6 (2k-1)^2$
$\frac{1}{5} + \frac{1}{4} + \frac{1}{3} + \frac{1}{2} + \frac{1}{1}$	$\frac{1}{6-k}$	$\sum_{k=1}^5 \frac{1}{6-k}$
$\frac{1}{2} + \frac{1}{2.2} + \frac{1}{2.4} + \frac{1}{2.6} + \frac{1}{2.8} + \frac{1}{3}$	$\frac{1}{1.8+k \times 0.2}$	$\sum_{k=1}^6 \frac{1}{1.8+k \times 0.2}$
$\sin(\frac{\pi}{5}) + \sin(2\frac{\pi}{5}) + \sin(3\frac{\pi}{5}) + \sin(4\frac{\pi}{5}) + \sin(5\frac{\pi}{5})$	$\sin(k\frac{\pi}{5})$	$\sum_{k=1}^5 \sin(k\frac{\pi}{5})$

There is a compact notation that focuses attention on the generic term:

$$\sum_{k=1}^{10} \left[\left(\frac{k}{10} \right)^2 \times \frac{1}{10} \right]$$

Σ is the Greek letter, capital sigma, to which the Latin letter *S* corresponds, and symbolizes sum. The entire symbol is read “The sum from k equal to 1 to 10 of $\left(\frac{k}{10}\right)^2$ times $\frac{1}{10}$ ”. It may also be read as “The sum from k equal to 1 to k equal to 10 of $\left(\frac{k}{10}\right)^2$ times $\frac{1}{10}$ ” and might be written

$$\sum_{k=1}^{10} \left[\left(\frac{k}{10} \right)^2 \times \frac{1}{10} \right] \quad \text{or} \quad \sum_{k=1}^{k=10} \left(\frac{k}{10} \right)^2 \times \frac{1}{10}$$

The second form is ambiguous, but both are the same because of the distributive property of the number system. The sums

$$\sum_{k=1}^{10} \left[\left(\frac{k}{10} \right)^2 + \frac{1}{10} \right] \quad \text{and} \quad \sum_{k=1}^{k=10} \left(\frac{k}{10} \right)^2 + \frac{1}{10}$$

are ambiguous and are not equal.

$$\sum_{k=1}^{10} \left[\left(\frac{k}{10} \right)^2 + \frac{1}{10} \right] \neq \left[\sum_{k=1}^{10} \left(\frac{k}{10} \right)^2 \right] + \frac{1}{10}$$

Typesetters find the Σ notation preferable as it is much more compact. In fact, after you use it a while, you will likely find that you can more quickly grasp the meaning of the sum with the shorter notation.

It will help you to use algebra like

$$\left[\sum_{k=1}^{10} \left(\frac{k}{10} \right)^2 \times \frac{1}{10} \right] = \left[\sum_{k=1}^{10} \left(\frac{k}{10} \right)^2 \right] \times \frac{1}{10}$$

This is use of the distributive property, and can be seen from long notation with which you are familiar:

$$\begin{aligned} & \left[\sum_{k=1}^{10} \left(\frac{k}{10} \right)^2 \times \frac{1}{10} \right] = \\ & \left[\left(\frac{1}{10} \right)^2 \times \frac{1}{10} + \left(\frac{2}{10} \right)^2 \times \frac{1}{10} + \cdots + \left(\frac{9}{10} \right)^2 \times \frac{1}{10} + \left(\frac{10}{10} \right)^2 \times \frac{1}{10} \right] = \\ & \left[\left(\frac{1}{10} \right)^2 + \left(\frac{2}{10} \right)^2 + \cdots + \left(\frac{9}{10} \right)^2 + \left(\frac{10}{10} \right)^2 \right] \times \frac{1}{10} = \\ & \left[\sum_{k=1}^{10} \left(\frac{k}{10} \right)^2 \right] \times \frac{1}{10} \end{aligned}$$

A.2 Mathematical Induction.

Mathematical Induction is a powerful way of thinking that allows one to prove an infinite number of statements with a finite set of sentences. That is a pretty good trade.

We use the method of Mathematical Induction to show that Equation 9.4,

$$1^2 + 2^2 + 3^2 + \cdots + n^2 = \sum_{k=1}^{k=n} k^2 = \frac{n(n+1)(2n+1)}{6}$$

is valid for all integers n . The method extends to many equations and other settings. To show its use in other settings we describe the problem of the "Tower of Hanoi" and its solution.

Mathematical Induction.

Hypothesis. Suppose S_1, S_2, S_3, \dots is an infinite sequence of statements, and

1. S_1 is true, and
2. for every positive integer, n , if S_n is true then S_{n+1} is true.

Conclusion. Then every statement in $S_1, S_2, S_3 \dots$ is true.

Example A.2.1 Demonstration of the validity of

$$1^2 + 2^2 + 3^2 + \cdots + n^2 = \frac{n(n+1)(2n+1)}{6}$$

For every positive integer, n , let S_n be the statement

$$1^2 + 2^2 + 3^2 + \cdots + n^2 = \frac{n(n+1)(2n+1)}{6}$$

Then S_1 is the statement,

$$1^2 = \frac{1(1+1)(2 \cdot 1 + 1)}{6} = \frac{6}{6} = 1, \quad \text{statement } S_1 \text{ is true,}$$

and the Induction Hypothesis 1 is satisfied.

Suppose n is a positive integer and S_n is true. Then

$$\begin{aligned}
 1^2 + 2^2 + 3^2 + \cdots + n^2 &= \frac{n(n+1)(2n+1)}{6} \\
 1^2 + 2^2 + 3^2 + \cdots + n^2 + (n+1)^2 &= \frac{n(n+1)(2n+1)}{6} + (n+1)^2 \\
 &= \frac{n(n+1)(2n+1) + 6(n+1)^2}{6} \\
 &= \frac{(n+1)(n(2n+1) + 6(n+1))}{6} \\
 &= \frac{(n+1)(2n^2 + 7n + 6)}{6} \\
 &= \frac{(n+1)(n+2)(2n+3)}{6} \\
 1^2 + 2^2 + 3^2 + \cdots + n^2 + (n+1)^2 &= \frac{(n+1)((n+1)+1)(2(n+1)+1)}{6}
 \end{aligned}$$

The last equation is S_{n+1} . On the assumption that S_n is true, we have shown that S_{n+1} is true, and the Induction Hypothesis 2 is satisfied. Therefore, every statement in S_1, S_2, S_3, \dots is true.

End of Proof. ■

Example A.2.2 .

There is a puzzle in which there is a board with three vertical spikes. On one of the spikes there is a stack of round discs no two of which are of the same size, and no disc of one size is on top of a disc of a smaller size. See Figure A.1

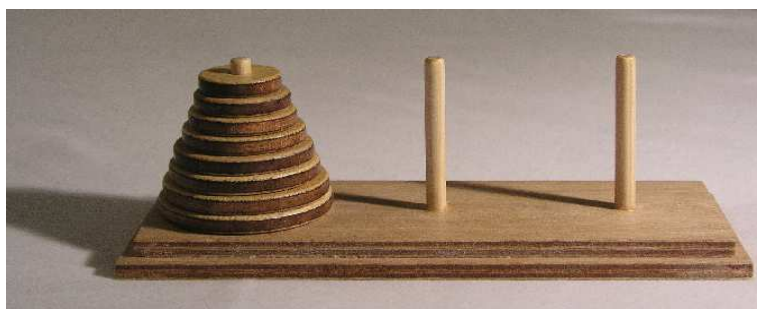

Figure A.1: A picture of the puzzle, The Tower of Hanoi, copied from http://en.wikipedia.org/wiki/Tower_of_Hanoi, figure posted by Ævar Arnfjörö Bjarmason.

The objective of the puzzle is to move the entire stack to another rod, obeying the following rules:

- Only one disk may be moved at a time.
- Each move consists of taking the upper disk from one of the spikes and placing it on another spike (there may be disks already on that spike).

- No disk may be placed on top of a smaller disk.

The question is "Can the puzzle be solved for all numbers of discs on the first spike?"

Consider some early cases.

Case of one disc. If there is only one disc, easy. Move that disc to another spike.

Case of two discs. Still pretty easy. Move the top disc to another spike; move the bottom disc to the remaining spike; put the top disc on top of the bottom disc.

Case of three discs. Not too hard, and we leave this case for you to do.

Induction. For each positive integer, n , let S_n be the statement

S_n : The puzzle with n discs can be solved.

Our goal is to prove that all of the statements, S_1, S_2, \dots are true.

We have just seen that the puzzle with one disc can be solved. Therefore, S_1 is true and Induction Hypothesis 1 is satisfied.

We do not have to prove it, but we also showed that S_2 is true.

Induction Hypothesis 2. Suppose n is a positive integer, and S_n is true.

Consider a puzzle with $n + 1$ discs.

- S_n is true, so the puzzle with n discs can be solved. Use those steps to move the top n discs to another spike.
- Move the bottom disc to the empty spike.
- Move the top n discs from the spike on which you put them onto the spike that has the bottom disc.

The puzzle with $n + 1$ discs has been solved, so S_{n+1} is true.

By the induction hypothesis, all of S_1, S_2, \dots are true.

Explore A.2.1 The puzzle with one disc was solved with one step. The puzzle with two discs was solved with three steps. Compute the number of steps to solve the puzzles with 3, 4, and 5 discs, and guess a formula for the number of steps to solve the n -disc puzzle. Prove by induction that your formula is correct.